

1.4 MESH CURRENT ANALYSIS

While Kirchhoff's Laws give us the basic method for analysing any complex electrical circuit, there are different ways of improving upon this method by using **Mesh Current Analysis** or **Nodal Voltage Analysis** that results in a lessening of the math's involved and when large networks are involved this reduction in maths can be a big advantage.

For example, consider the electrical circuit example from the previous section.

Mesh Current Analysis Circuit

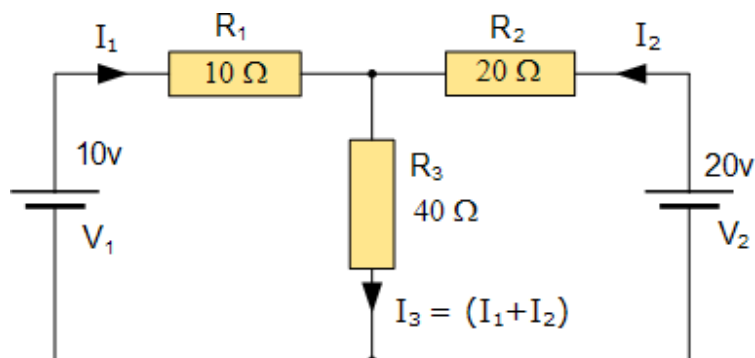

Figure 1.4.1 Mesh circuit

[Source: "Basic Electrical and Electronics Engineering" by Kothari D.P, Page – 75]

One simple method of reducing the amount of math's involved is to analyse the circuit using Kirchhoff's Current Law equations to determine the currents, I_1 and I_2 flowing in the two resistors. Then there is no need to calculate the current I_3 as its just the sum of I_1 and I_2 . So Kirchhoff's second voltage law simply becomes:

- Equation No 1 : $10 = 50I_1 + 40I_2$
- Equation No 2 : $20 = 40I_1 + 60I_2$

therefore, one line of math's calculation have been saved.

Mesh Current Analysis

An easier method of solving the above circuit is by using **Mesh Current Analysis** or **Loop Analysis** which is also sometimes called **Maxwell's Circulating Currents** method. Instead of labelling the branch currents we need to label each "closed loop" with a circulating current.

As a general rule of thumb, only label inside loops in a clockwise direction with circulating currents as the aim is to cover all the elements of the circuit at least once. Any required branch current may be found from the appropriate loop or mesh currents as before using Kirchhoff's method.

For example : $i_1 = I_1$, $i_2 = -I_2$ and $I_3 = I_1 - I_2$

We now write Kirchhoff's voltage law equation in the same way as before to solve

them but the advantage of this method is that it ensures that the information obtained from the circuit equations is the minimum required to solve the circuit as the information is more general and can easily be put into a matrix form.

For example, consider the circuit from the previous section.

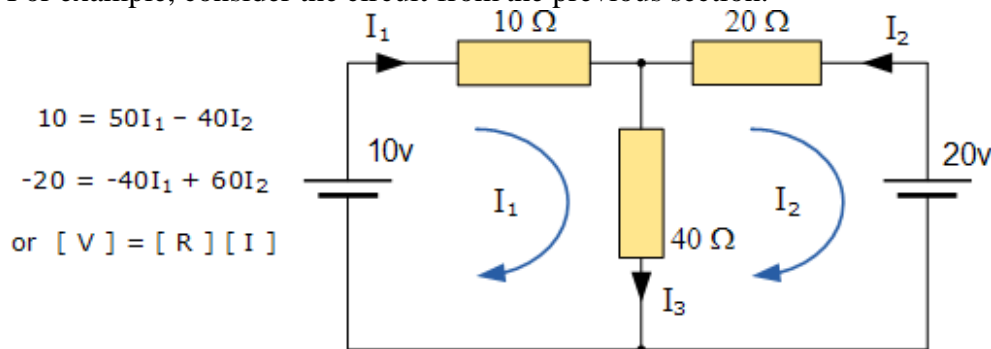

Figure 1.4.2 Mesh Circuit

[Source: "Basic Electrical and Electronics Engineering" by Kothari D.P., Page – 79]

These equations can be solved quite quickly by using a single mesh impedance matrix Z. Each element ON the principal diagonal will be "positive" and is the total impedance of each mesh. Where as, each element OFF the principal diagonal will either be "zero" or "negative" and represents the circuit element connecting all the appropriate meshes.

First we need to understand that when dealing with matrices, for the division of two matrices it is the same as multiplying one matrix by the inverse of the other as shown.

$$[V] = [I] \times [R] \quad \text{or} \quad [R] \times [I] = [V]$$

$$\begin{bmatrix} 50 & -40 \\ -40 & 60 \end{bmatrix} \times \begin{bmatrix} I_1 \\ I_2 \end{bmatrix} = \begin{bmatrix} 10 \\ -20 \end{bmatrix}$$

$$I = \frac{V}{R} = R^{-1} \times V$$

$$\text{Inverse of } R = \begin{bmatrix} 60 & 40 \\ 40 & 50 \end{bmatrix}$$

$$|R| = (60 \times 50) - (40 \times 40) = 1400$$

$$\therefore R^{-1} = \frac{1}{1400} \begin{bmatrix} 60 & 40 \\ 40 & 50 \end{bmatrix}$$

$$[I] = [R^{-1}] \times [V]$$

$$\begin{bmatrix} I_1 \\ I_2 \end{bmatrix} = \frac{1}{1400} \begin{bmatrix} 60 & 40 \\ 40 & 50 \end{bmatrix} \times \begin{bmatrix} 10 \\ -20 \end{bmatrix}$$

$$I_1 = \frac{(60 \times 10) + (40 \times -20)}{1400} = \frac{-200}{1400} = -0.143 A$$

$$I_2 = \frac{(40 \times 10) + (50 \times -20)}{1400} = \frac{-600}{1400} = -0.429 A$$

[V] gives the total battery voltage for loop 1 and then loop 2

[I] states the names of the loop currents which we are trying to find [R] is the resistance matrix

[R⁻¹] is the inverse of the [R] matrix

and this gives I₁ as -0.143 Amps and I₂ as -0.429 Amps As : I₃ = I₁ - I₂

The combined current of I₃ is therefore given as : -0.143 - (-0.429) = 0.286 Amps

which is the same value of 0.286 amps, we found using **Kirchoff's** circuit law in the previous tutorial.