

Reg. No. :

--	--	--	--	--	--	--	--	--	--	--	--

Question Paper Code : 40435

B.E./B.Tech. DEGREE EXAMINATIONS, NOVEMBER/DECEMBER 2021.

Third Semester

Electronics and Communication Engineering

EC 8351 – ELECTRONIC CIRCUITS – I

(Common to Electronics and Telecommunication Engineering)

(Regulations 2017)

Time : Three hours

Maximum : 100 marks

Answer ALL questions.

PART A — (10 × 2 = 20 marks)

1. Predict the collector and base current for the given specification $h_{fe} = 80$, $V_{BE(ON)} = 0.7V$, $R_c = 5K\Omega$, $R_b = 10K\Omega$ and $R_c = 5K\Omega$.
2. Specify the main idea of compensation techniques.
3. Assess why R_E is replaced a constant current bias in a differential amplifier.
4. Draw the cascade amplifier and its ac equivalent circuit.
5. The MOSFET is used to amplify a time-varying voltage. Justify.
6. If the mid-band gain is 100 and a half-power, frequencies are $f_L = 40Hz$ and $f_H = 16kHz$. Calculate the amplifier gain at 20Hz and 20kHz frequencies.
7. What is the effect of miller's capacitance on the frequency response of an amplifier?
8. Express the equation for the overall lower and upper cut-off frequency of the multistage amplifier.
9. Estimate the ripple voltage of a full-wave rectifier with a 100mF filter capacitor connected to a load drawing 50 mA.
10. Draw the circuit diagram of the regulated DC power supply.

PART B — (5 × 13 = 65 marks)

11. (a) (i) Draw and explain the circuit of voltage divider bias circuit using BJT. Also derive the expression for stability factor. (8)
- (ii) Summarize bias compensation technique using diode. (5)

Or

- (b) For the circuit shown below with transistor parameters $I_{DSS} = 12\text{mA}$, $V_p = 4\text{V}$ and $\lambda = 0.008\text{V}^{-1}$. Determine the small signal voltage gain $A_v = V_o / V_i$. (13)

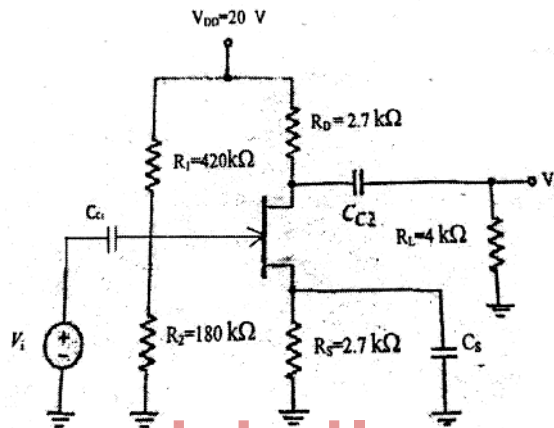

12. (a) Explain the operation of the basic common base amplifier circuit and derive the expressions for its small-signal voltage gain, current gain, input impedance, and output impedance. (13)

Or

- (b) (i) Illustrate the working of bootstrapped Darlington circuit with a neat sketch. (8)
- (ii) Outline the transfer characteristics of the differential amplifier. (5)
13. (a) (i) With the help of a neat diagram, explain how JFET can be used as an amplifier. (7)
- (ii) Explain the working principle of small-signal low-frequency model of JFET. (6)

Or

- (b) (i) Draw and explain the small-signal model of a MOSFET. (8)
- (ii) Draw and explain drain and transfer characteristics of depletion type MOSFET. (5)

14. (a) Explain the operation of a high-frequency common source FET amplifier with a neat diagram? Derive the expression for (i) Voltage gain (ii) Input admittance (iii) Input capacitance (iv) Output admittance. (13)

Or

- (b) (i) Discuss the effect of coupling and bypass capacitor's on the low-frequency response of the BJT amplifier. (7)
(ii) Draw the circuit diagram of the RC coupled amplifier. Explain the operation and its frequency response. (6)
15. (a) (i) What is a rectifier? Explain in detail the operation of a half-wave rectifier. (9)
(ii) Write a brief note about PIV in the PN diode. (4)

Or

- (b) Explain in detail the operation of the switched-mode power supply with a neat diagram. (13)

PART C — (1 × 15 = 15 marks)

16. (a) A full-wave rectifier circuit is fed from a transformer having a center-tapped secondary winding. The RMS voltage from either end of secondary to center tap is 20V. If the diode forward resistance is $3\ \Omega$ and that of the half secondary is $5\ \Omega$ for a load of $1\ \text{K}\Omega$, estimate the power delivered to load, percentage of regulation at full load, efficiency at full load, and TUF of secondary. (15)

Or

- (b) What are alpha and beta cut off frequencies? Derive the equation for (i) CE short circuit current gain and (ii) CE current gain with resistive load. (15)
