

binils.com – Free Anna University, Polytechnic, School Study Material

binils.com

UNIT I

STRESS AND STRAIN

1.1 STRENGTH OF MATERIALS

Strength of materials is a subject which deals with the detailed study about the effect of external forces acts on materials and ability of material to resist deformations due to cohesion between the molecules. The study of strength of materials often refers to various methods of calculating the stresses and strains in structural members, such as beams, columns, and shafts.

1.2. STIFFNESS

The Stiffness may be defined as an ability of a material to withstand load without deformation.

1.3. STRESS

When an external force acts on a body it undergoes some deformation and at the same time the body resists deformation. The magnitude of the applied force is numerically equal to the internal resisting force. This internal resisting force per unit area is called stress.

Mathematically

$$\text{Stress } (\sigma) = \frac{\text{Force}(P)}{\text{Area}(A)}$$

The unit of Stress is N/mm^2 or KN/m^2 . depending upon the units of Force and Area.

1.4. STRAIN

When a body is subjected to an external force, there is some change in dimension of the body. The ratio of change in dimension to the original dimension is known as strain.

$$\text{Strain} = \frac{\text{Change in dimension}}{\text{Original dimension}}$$

It has no unit.

1.5. TYPES OF STRESSES

There are mainly three types of stresses. They are:

- a. Tensile stress,
- b. Compressive stress and
- c. Shear stress.

a. Tensile stress & Tensile Strain

When a member is subjected to equal and opposite pulls as shown in figure, as a result of this there is increase in length. The Stress induced at any cross section of the member is called Tensile Stress.

$$\text{Tensile Stress} = \frac{\text{Tensile load}}{\text{Area}}$$

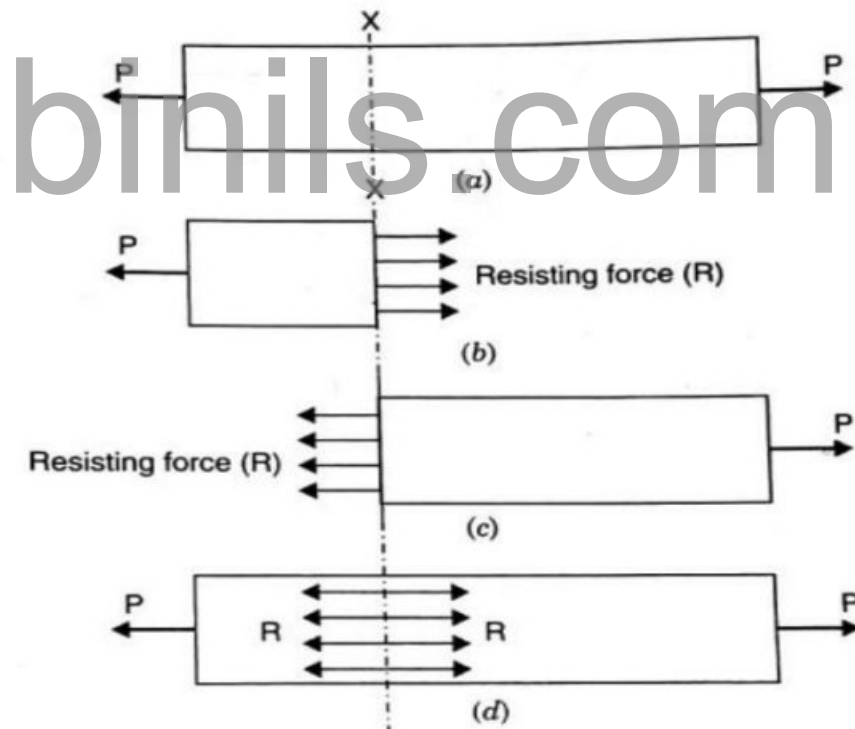

The ratio of increase in length to the original length is known as Tensile Strain

$$\text{Tensile Strain } (e) = \frac{\text{Increase in length } (\Delta l)}{\text{Original length } (l)}$$

b. Compressive Stress and Compressive Strain

When a member is subjected to equal and opposite pushes as shown in figure, as a result of this there is decreased in length. The Stress induced at any cross section of the member is called Compressive Stress.

$$\text{Compressive Stress} = \frac{\text{Compressive load}}{\text{Area}}$$

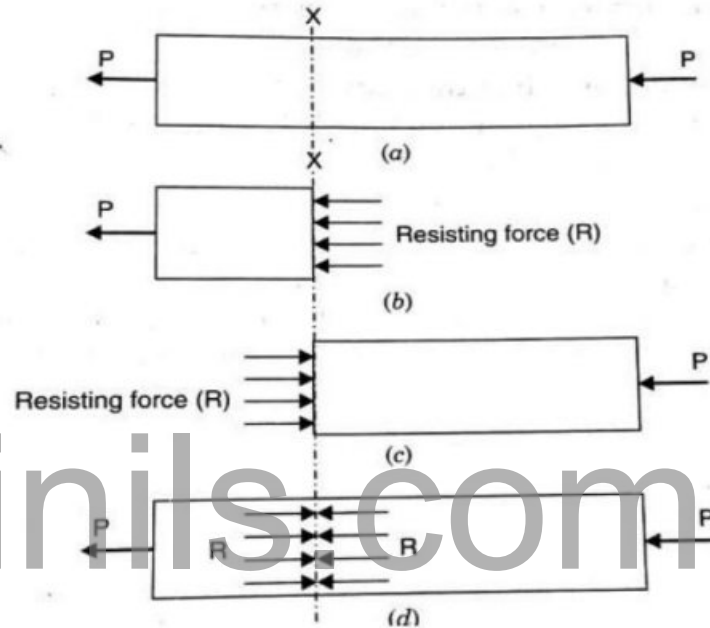

The ratio of increase in length to the original length is known as Tensile Strain

$$\text{Tensile Strain}(e) = \frac{\text{decrease in length}(\Delta l)}{\text{Original length}(l)}$$

C. Shear Stress and Shear Strain

When the member is subjected to equal and opposite forces acts tangentially at any cross sectional plane of a body the body tending to slide one part of the body over the other part as shown in figure the stress induced in that section is called shear stress and the corresponding strain is known as shear strain.

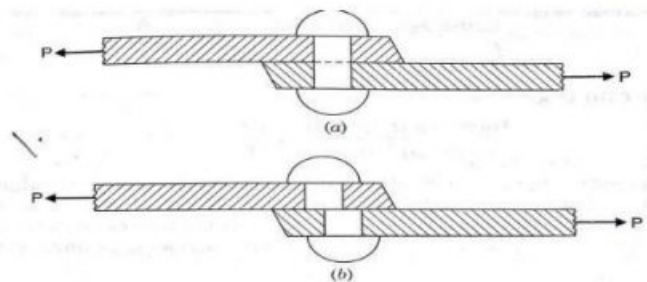

1.6. VOLUMETRIC STRAIN

Volumetric strain is defined as the ratio of change in volume to the original volume

$$\text{Volumetric Strain} = \frac{\text{Change in Volume}(\Delta v)}{\text{Original Volume}(v)}$$

1.7. HOOKE'S LAW

It States that when a material is loaded, within its elastic limit, the stress is directly proportional to the strain.

$$\text{Stress } (\sigma) \propto \text{strain}$$

1.8. FACTOR OF SAFETY

It is defined as the ratio of ultimate stress to the Permissible stress(working stress)

$$\text{Factor of safety} = \frac{\text{Ultimate Stress}}{\text{Permissible Stress}}$$

Problem 1.1 A mild steel rod 2m long and 3Cm diameter is subjected to an axial pull of 10KN. If E for steel is $2 \times 10^5 \text{ N/mm}^2$. Find (a) Stress, (b) Strain, (C) Elongation of the rod.

Given:

Length of the rod,	$L = 2\text{m} = 2000\text{mm};$
Diameter of the rod,	$D = 3\text{cm} = 30\text{mm};$
Axial load,	$P = 10\text{KN} = 10 \times 10^3\text{N};$
Young's Modulus,	$E = 2 \times 10^5 \text{ N/mm}^2$

To find:

(a) Stress, (b) Strain, (C) Elongation of the rod

Solution:

We know that,

$$\text{Stress}(\sigma) = \frac{\text{Load}(P)}{\text{Area}(A)} = \frac{10 \times 10^3}{\frac{\pi}{4} \times D^2} = \frac{10 \times 10^3}{\frac{\pi}{4} \times 30^2}$$

$$(\sigma) = 14.14 \text{ N/mm}^2.$$

$$\text{Young's modulus, (E)} = \frac{\text{Stress}}{\text{Strain}}$$

$$\therefore \text{Strain (e)} = \frac{\text{Stress}}{\text{Young's Modulus}}$$

$$= \frac{14.14}{2 \times 10^5}$$

$$= 7.07 \times 10^{-5}$$

$$\text{Strain (e)} = \frac{\delta l}{l}$$

$$\text{or } 7.07 \times 10^{-5} = \frac{\delta l}{2000}$$

$$\delta l = 2000 \times 7.07 \times 10^{-5}$$

$$= 0.141 \text{ mm}$$

Problem:1.2 A hollow Cylinder 2m long has an outside diameter of 50mm and inside diameter of 30mm. If the cylinder is carrying a load of 25kN. Find the stress in the cylinder. Also find the deformation of the cylinder. Take E=100Gpa.

Given Data:

Length, $L = 2\text{m} = 2000\text{mm},$

Outside diameter, $D = 50 \text{ mm},$

Inside diameter, $d = 30 \text{ mm},$

Load, $P = 25 \text{ kN} = 25 \times 10^3\text{N}$

Young's modulus, $E = 100 \text{ GPa} = 100 \times 10^9\text{Pa}$

$$= 100 \times 10^9\text{N/m}^2 = 100 \times \frac{10^9}{10^6} \text{ N/mm}^2$$

$$= 100 \times 10^3\text{N/mm}^2$$

To find: Stress(σ) and Deformation(Δl)

STRENGTH OF MATERIALS

Solution:

$$\begin{aligned}\text{Stress}(\sigma) &= \frac{\text{Load}(P)}{\text{Area}(A)} \\ &= \frac{25 \times 10^3}{\frac{\pi}{4} \times (D^2 - d^2)} \times \frac{\pi}{4} \times (50^2 - 30^2) \times 100 \times 10^3 \\ &= \frac{25 \times 10^3}{\frac{\pi}{4} \times (50^2 - 30^2)} \\ &= 19.89 \text{N/mm}^2.\end{aligned}$$

$$\begin{aligned}\text{Deformation}(\delta l) &= \frac{Pl}{AE} \\ &= \frac{(25 \times 10^3 \times 2000)}{\frac{\pi}{4} \times (50^2 - 30^2) \times 100 \times 10^3} \\ &= 0.398 \text{mm}\end{aligned}$$

Problem:1.3 A short hollow cast iron cylinder of external diameter 200mm is to carry a compressive load of 1.9MN. Determine the inner diameter of the cylinder, if the ultimate crushing stress for the material is 480MN/m². Use the factor of safety of 4.

Given Data:

External Diameter,	D = 200mm,
Load,	P = 1.9MN = 1.9 × 10 ⁶ N,
Ultimate Stress,	$\sigma_u = 480 \text{MN/m}^2 = 480 \frac{10^6}{10^6} \text{N/mm}^2$ = 480N/mm ² ,
Factor of Safety	= 4

To Find: Internal diameter(d)

Solution:

$$\text{Working Stress} \quad (\sigma) = \frac{\text{Ultimate Stress}}{\text{Factor of Safety}}$$

$$= \frac{480}{4}$$

$$= 120\text{N/mm}^2$$

$$\text{Stress}(\sigma) = \frac{\text{Load}(P)}{\text{Area}(A)}$$

$$\text{Or } 120 = \frac{1.9 \times 10^6}{\frac{\pi}{4} \times (200^2 - d^2)}$$

$$\text{Or } 40000 - d^2 = \frac{1.9 \times 10^6}{\frac{\pi}{4} \times 120^2}$$

$$\text{Or } d^2 = 40000 - 20159.58$$

$$= 19840.4\text{mm}^2$$

$$\therefore d = \sqrt{19840.4}$$

$$= 140.856\text{mm}$$

$$= \text{say } 141\text{mm}$$

binils.com

1.9. STRESSES IN BARS OF VARYING CROSS SECTIONS

Consider the following non-uniform cross sections of a member AB,BC and CD having cross sectional areas of A_1, A_2 and A_3 with their lengths of L_1, L_2 and L_3 as shown in figure.

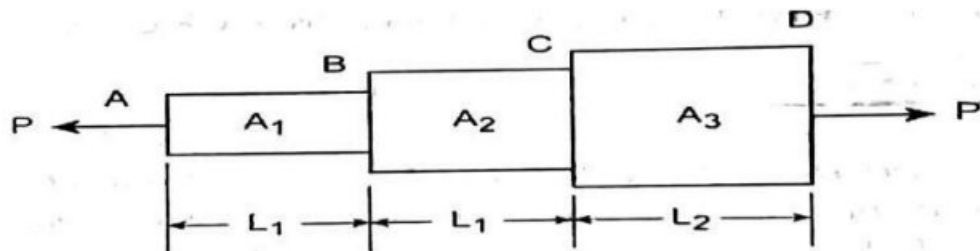

$$\text{Tensile stress in portion, AB} = \frac{\text{Load}}{\text{Area}} = \frac{P}{A_1}$$

$$\text{Elongation of AB } (\delta L_1) = \frac{PL_1}{A_1 E}$$

STRENGTH OF MATERIALS

$$\text{Tensile stress in portion,BC} = \frac{\text{Load}}{\text{Area}} = \frac{P}{A_2}$$

$$\text{Elongation of BC} \quad (\delta L_2) = \frac{PL_2}{A_2E}$$

$$\text{Tensile stress in portion,CD} = \frac{\text{Load}}{\text{Area}} = \frac{P}{A_3}$$

$$\text{Elongation of CD} (\delta L_3) = \frac{PL_3}{A_3E}$$

$$\begin{aligned} \text{Total Elongation} &= \delta L_1 + \delta L_2 + \delta L_3 \\ &= \frac{PL_1}{A_1E} + \frac{PL_2}{A_2E} + \frac{PL_3}{A_3E} \\ &= \frac{P}{E} \left[\frac{L_1}{A_1} + \frac{L_2}{A_2} + \frac{L_3}{A_3} \right] \\ (\delta L) &= \frac{P}{E} \left[\frac{L_1}{A_1} + \frac{L_2}{A_2} + \frac{L_3}{A_3} \right] \end{aligned}$$

Problem:1.4 A bar 0.3m long is 50mm square in section for 120mm of its length, 25mm diameter for 80mm length and of 40mm diameter for the remaining length. If a tensile force of 100KN is applied to the bar Calculate the maximum and minimum stress produced in it and the total elongation. Take $E=200\text{GN/m}^2$ and assume uniformly distribution of the load over the section.

Given data:

Total length	$L = 0.3\text{m} = 300\text{mm},$
Width of first portion	$b_1 = 50\text{mm},$
Length of first portion	$L_1 = 120\text{mm},$
Diameter of second portion	$D_2 = 25\text{mm},$
Length of second portion,	$L_2 = 80\text{mm},$
Diameter of third portion,	$D_3 = 40\text{mm},$
Load,	$P = 100\text{KN} = 100 \times 10^3\text{N},$
	$E = 200\text{GN/m}^2 = 200 \times 10^9\text{N/m}^2$

$$= 200 \times \frac{10^9}{10^6} \text{N/mm}^2 = 200 \times 10^3 \text{N/mm}^2$$

To find:(1) maximum and minimum Stress

(2) Total Elongation

Solution:

$$L = L_1 + L_2 + L_3$$

$$300 = 120 + 80 + L_3$$

$$L_3 = 300 - 200 = 100 \text{mm}$$

(1) Maximum and Minimum Stress:

$$(\sigma_1) = \frac{\text{Load}}{\text{Area}} = \frac{P}{A_1}$$

$$\text{Area in section 1}(A_1) = 50 \times 50 = 2500 \text{ mm}^2$$

$$= \frac{100 \times 10^3}{2500}$$

$$\sigma_1 = 40 \text{N/mm}^2$$

$$\text{Stress in section.2 } (\sigma_2) = \frac{\text{Load}}{\text{Area}} = \frac{P}{A_2}$$

$$\text{Area in section.2 } (A_2) = \frac{\pi}{4} D^2$$

$$= \frac{\pi}{4} 25^2$$

$$= 490.87 \text{mm}^2$$

$$= \frac{100 \times 10^3}{490.87}$$

$$\sigma_2 = 203.72 \text{N/mm}^2$$

$$\text{Stress in Section 3 } (\sigma_3) = \frac{\text{Load}}{\text{Area}} = \frac{P}{A_3}$$

$$\text{Area in section 3 } (A_3) = \frac{\pi}{4} 40^2 = 1256.64 \text{mm}^2$$

$$= \frac{100 \times 10^3}{1256.64}$$

$$= 79.58 \text{N/mm}^2$$

(2) Total Elongation

$$\begin{aligned}
 (\delta L) &= \frac{P}{E} \left[\frac{L_1}{A_1} + \frac{L_2}{A_2} + \frac{L_3}{A_3} \right] \\
 &= \frac{100 \times 10^3}{200 \times 10^3} \left[\frac{120}{2500} + \frac{80}{490.87} + \frac{100}{1256.64} \right] = 0.145 \text{ mm}
 \end{aligned}$$

1.10. PRINCIPLE OF SUPERPOSITION.

When a number of loads are acting on a body, the resulting strain, according to principle of superposition, will be the algebraic sum of strains caused by individual loads.

While using this principle for an elastic body which is subjected to a number of direct forces (tensile or compressive) at different sections along the length of the body, first the free body diagram of individual section is drawn. Then the deformation of each section is obtained. The total deformation of the body will be then equal to the algebraic sum of deformations of the individual sections.

Problem 1.5. A brass bar, having cross-sectional area of 1000 mm^2 , is subjected to axial forces as shown in Fig.

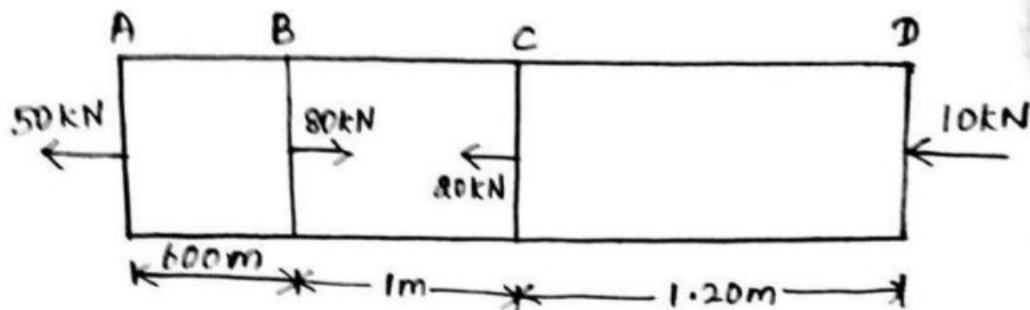

Given Data: $A = 1000 \text{ mm}^2$, $E = 1.05 \times 10^5 \text{ N/mm}^2$

To find :

The total elongation of the bar.

Solution:

The force of 80 KN acting at B is split up into three forces of 50KN, 20KN and 10KN. Then the part AB of the bar will be subjected to a tensile load of 50 KN, part BC

is subjected to a compressive load of 20KN and the part BD is subjected to a compressive load of 10KN as shown in figure.

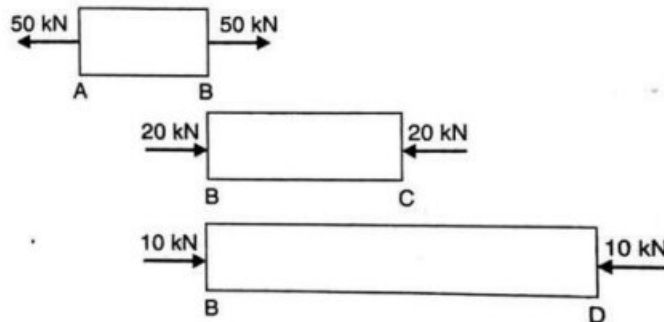

Part AB. This part is subjected to a tensile load of 50KN. Hence there will be increase in length of this part.

Therefore increase in the length of AB

$$\begin{aligned}
 &= \frac{P_1}{AE} \times L_1 \\
 &= \frac{50 \times 1000}{1000 \times 1.05 \times 10^5} \times 600 \\
 &= 0.2857 \text{ mm}
 \end{aligned}$$

Part BC. This part is subjected to a compressive load of 20 KN or 20000 N. Hence there will be decrease in length of this part.

Therefore Decrease in length of BC

$$\begin{aligned}
 &= \frac{P_2}{AE} \times L_2 \\
 &= \frac{20 \times 1000}{1000 \times 1.05 \times 10^5} \times 1000 \\
 &= 1.1904 \text{ mm.}
 \end{aligned}$$

Part BD. This part is subjected to a compressive load of 10 KN or 10,000 N. Hence there will be decrease in length of this part.

Therefore Decrease in the length of BD

$$\begin{aligned}
 &= \frac{P_3}{AE} \times L_3 \\
 &= \frac{10 \times 1000}{1000 \times 1.05 \times 10^5} \times 2200
 \end{aligned}$$

Since $L_3 = 1.2 + 1 = 2.2$ m or 2200 mm

$$= 0.2095 \text{ mm.}$$

Total elongation of bar $= 0.2857 - 0.1904 - 0.2095$

(Taking +ve sign for increase in length and -ve sign for decrease in length)

$$= -0.1142 \text{ mm}$$

Negative sign shows, that there will be decrease in length of the bar.

Problem 1.6. A member ABCD is subjected to point loads P_1 , P_2 , P_3 and P_4 as shown in figure.

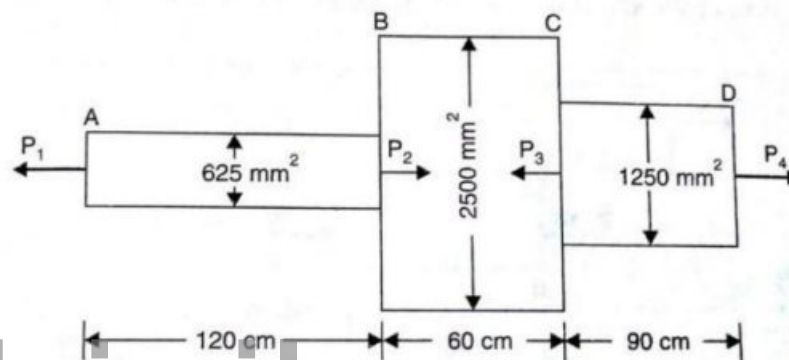

Calculate the force P_2 necessary for equilibrium, if $P_1 = 45$ kN, $P_3 = 45$ kN and $P_4 = 130$ kN. Determine the total elongation of the member, assuming the modulus of elasticity to be 2.1×10^5 N/mm².

Given Data:

Part AB : Area, $A_1 = 625$ mm² and Length $L_1 = 120$ cm = 1200 mm

Part BC: Area, $A_2 = 2500$ mm² and Length $L^2 = 60$ cm = 600 mm

Part CD: Area, $A_3 = 1250$ mm² and Length $L_3 = 90$ cm = 900 mm

Value of $E = 2.1 \times 10^5$ N/mm²

To Find : Force P_2 and the total elongation

Solution:

Value of P_2 necessary for equilibrium:

Resolve the forces on the rod along its axis (i.e., equating the forces acting towards right to those acting towards left), We get

$$P_1 + P_3 = P_2 + P_4$$

$$45 + 450 = P_2 + 130$$

Or
$$P_2 = 45 + 450 - 130 = 365 \text{ kN.}$$

The force of 365 kN acting at B is split into two forces of 45 kN and 320 kN (i.e., $365 - 45 = 320 \text{ kN}$).

The force of 450 kN acting at C is split into two forces of 320 kN and 130 kN (i.e., $450 - 320 = 130 \text{ kN}$) as shown in figure.

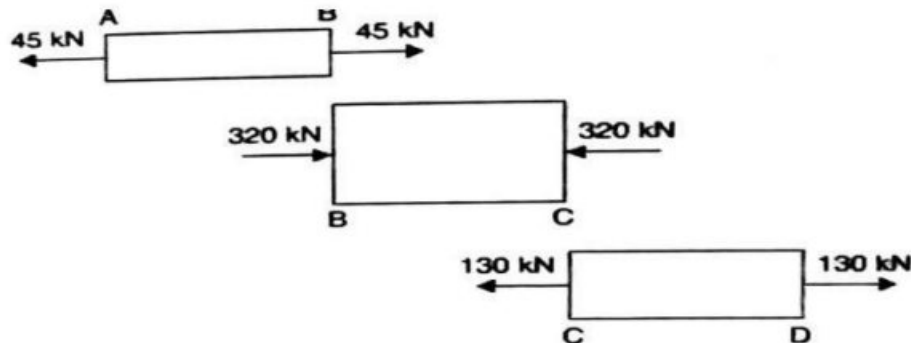

From Fig it is clear that part AB is subjected to a tensile load of 45 kN, Part BC is subjected to a compressive load of 320 kN and part CD is subjected to a tensile load of 130 kN.

Hence for part AB, there will be increase in length; for part BC there will be decrease in length and part CD there will be increase in length.

Therefore increase in the length of AB

$$\begin{aligned} &= \frac{P_1}{A_1} \times L_1 \\ &= \frac{45 \times 1000}{625 \times 2.1 \times 10^5} \times 1200 \\ &= \mathbf{0.4114 \text{ mm}} \end{aligned}$$

Therefore Decrease in length of BC

$$\begin{aligned} &= \frac{P_2}{A_2 E} \times L_2 \\ &= \frac{320 \times 1000}{2500 \times 2.1 \times 10^5} \times 600 \\ &= \mathbf{0.3657 \text{ mm.}} \end{aligned}$$

Therefore Increase in the length of CD

$$\begin{aligned}
 &= \frac{P_3}{A_3 E} \times L_3 \\
 &= \frac{130 \times 1000}{1250 \times 2.1 \times 10^5} \times 900 \\
 &= \mathbf{0.4457 \text{ mm.}}
 \end{aligned}$$

Total elongation of bar = $0.4114 - 0.3657 + 0.4457$
 (Taking +ve sign for increase in length and -ve sign for decrease in length)
 = **0.4914mm (extension).**

1.11. ANALYSIS OF BARS OF COMPOSITE SECTIONS

A bar, made up of two or more bars of equal lengths but of different materials rigidly fixed with each other and behaving as one unit for extension or contraction when subjected to an axial tensile or compressive loads, is called a composite bar.

For the composite bar the following two points are important:

1. The extension or contraction in each bar is equal. Hence deformation per unit length i.e., strain in each bar is equal.
2. The total external load on the composite bar is equal to the sum of the loads carried by each different material.

Figure shows a composite bar made up of two different materials.

Let P = Total load on the composite bar,

L = Length of composite bar and also lengths of bars of different materials,

A_1 = Area of cross-section of bar 1,

A_2 = Area fo cross-section of bar 2,

E_1 = Young's Modulus of bar1,

E_2 = Young's Modulus of bar 2,

P_1 = Load shared by bar 1,

P_2 = Load shared by bar 2,

σ_1 = Stress induced in bar 1 and

σ_2 = Stress induced in bar 2

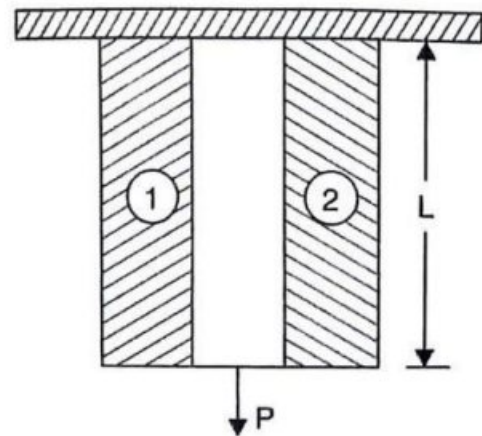

Now the total load on the composite bar is equal to the sum of the load carried by the two bars

Therefore $P = P_1 + P_2$... (i)

The stress in bar 1, $= \frac{\text{Load carried by bar 1}}{\text{Area of cross section of bar 1}}$

$$\sigma_1 = \frac{P_1}{A_1}$$

Or $P_1 = \sigma_1 A_1$... (ii)

Similarly stress in bar 2, $= \frac{\text{Load carried by bar 2}}{\text{Area of cross section of bar 2}}$

$$\sigma_2 = \frac{P_2}{A_2}$$

Or $P_2 = \sigma_2 A_2$... (iii)

Substituting the Values of P_1 and P_2 in equation (i), We get

$$P = \sigma_1 A_1 + \sigma_2 A_2$$
 ... (iv)

Since the ends of the two bars are rigidly connected, each bar will change in length by the same amount. Also the length of each bar is same and hence the ratio of change in length to the original length (*i.e.*, strain) will be same for each bar.

But strain in bar 1, $= \frac{\text{Stress in bar 1}}{\text{Young's modulus of bar 1}} = \frac{\sigma_1}{E_1}$

Similarly strain in bar 2, $= \frac{\text{Stress in bar 2}}{\text{Young's modulus of bar 2}} = \frac{\sigma_2}{E_2}$

But strain in bar 1 = Strain in bar 2

$$\frac{\sigma_1}{E_1} = \frac{\sigma_2}{E_2}$$
 ... (v)

From equations (iv) and (v), the stress σ_1 and σ_2 can be determined. By substituting the values of σ_1 and σ_2 in equations (ii) and (iii), the load carried by different materials may be computed.

Modular Ratio. The ratio of $\frac{E_1}{E_2}$ is called the modular ratio of the first material to the second.

Problem 1.7. A steel rod of 3 cm diameter is enclosed centrally in a hollow copper tube of external diameter 5 cm and internal diameter of 4 cm. The composite bar is then subjected to an axial pull of 45 kN. If the length of each bar is equal to 15 cm, determine:

STRENGTH OF MATERIALS

- (i) The stresses in the rod and tube, and
- (ii) Load carried by each bar,

Take E for steel $= 2.1 \times 10^5 \text{ N/mm}^2$ and for copper $= 1.1 \times 10^5 \text{ N/mm}^2$.

Given Data:

- $D_s = 3 \text{ cm} = 30 \text{ mm}$,
- $D_c = 5 \text{ cm} = 50 \text{ mm}$,
- $d_c = 4 \text{ cm} = 40 \text{ mm}$
- $P = 45 \text{ KN} = 45000 \text{ N}$
- $L = 15 \text{ cm} = 150 \text{ mm}$
- $E_s = 2.1 \times 10^5 \text{ N/mm}^2$
- $E_c = 1.1 \times 10^5 \text{ N/mm}^2$

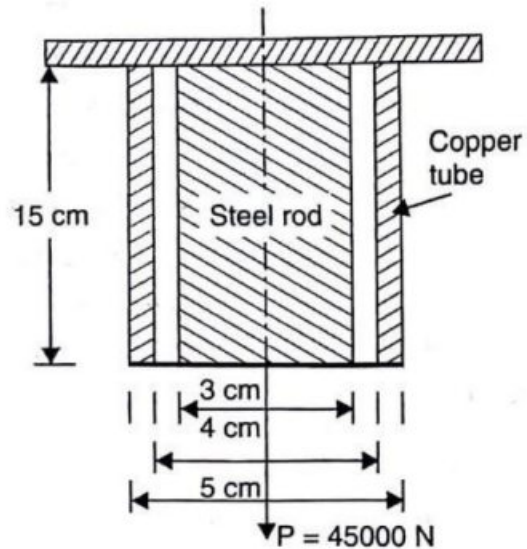

- To find** (i) The stress in the rod and tube, and
(ii) Load carried by each bar.

Solution:

Area of steel rod,

$$(A_s) = \frac{\pi D_s^2}{4}$$

$$= \frac{\pi \times 30^2}{4} = 706.86 \text{ mm}^2$$

Area of Copper tube (A_c)

$$= \frac{\pi}{4} [D_c^2 - d_c^2]$$

$$= \frac{\pi}{4} [50^2 - 40^2]$$

$$= 706.86 \text{ mm}^2$$

(i) The stress in the rod and tube

We know that,

Strain in steel = Strain in copper

or

$$\frac{\sigma_s}{E_s} = \frac{\sigma_c}{E_c}$$

$$\sigma_s = \frac{\sigma_c}{E_c} E_s = \frac{2.1 \times 10^5}{1.1 \times 10^5} \times \sigma_c = 1.909 \sigma_c \quad \dots(i)$$

$$\text{Now,} \quad \text{Stress} = \frac{\text{Load}}{\text{Area}}$$

$$\therefore \text{Load} = \text{Stress} \times \text{Area}$$

Load on steel + Load on copper = Total Load

$$\sigma_s \times A_s + \sigma_c \times A_c = P$$

$$1.909 \sigma_c \times 706.86 + \sigma_c \times 706.86 = 45000$$

$$\sigma_c (1.909 \times 706.86 + 706.86) = 45000$$

$$2056.25 \sigma_c = 45000$$

$$\sigma_c = \frac{45000}{2056.25} = 21.88 \text{ N/mm}^2.$$

Substituting the value of σ_c in equation (i), we get

$$\sigma_s = 1.909 \times 21.88$$

$$= 41.77 \text{ N/mm}^2.$$

(ii) Load carried by each bar

$$\text{As} \quad \text{Load} = \text{Stress} \times \text{Area}$$

$$\begin{aligned} \therefore \text{Load carried by steel rod, } P_s &= \sigma_s \times A_s \\ &= 41.77 \times 706.86 \\ &= 29525.5 \text{ N} \end{aligned}$$

$$\text{Load Carried by copper tube, } P_c = P - P_s$$

$$= 45000 - 29525.5$$

$$= 15474.5 \text{ N}$$

Problem 1.8. Two vertical rods one of steel and the other of copper are rigidly fixed at the top and 50 cm apart. Diameters and lengths of each rod are 2 cm and 400 cm respectively. A cross bar fixed to the rods at the lower ends carries a load of 5 kN such that the cross bar remains horizontal ever after loading. Find the stress in each rod and the position of the load on the bar. Take E for steel = $2 \times 10^5 \text{ N/mm}^2$ and E for copper = $1 \times 10^5 \text{ N/mm}^2$.

Given Data:

$$D_s = D_c = 2 \text{ cm} = 20 \text{ mm},$$

$$P = 5 \text{ kN} = 5000 \text{ N}$$

STRENGTH OF MATERIALS

$$L = 400 \text{ cm} = 4000 \text{ mm}$$

$$E_s = 2 \times 10^5 \text{ N/mm}^2$$

$$E_c = 1 \times 10^5 \text{ N/mm}^2$$

$$S = 50 \text{ cm} = 500 \text{ mm}$$

- To find** (i) The stress in each rod and
(ii) Position of the load.

Solution:

$$\text{Area of steel rod}(A_s) = \text{Area of copper rod}(A_c)$$

$$\begin{aligned} &= \frac{\pi D_s^2}{4} \\ &= \frac{\pi \times 20^2}{4} \\ &= 314.16 \text{ mm}^2 \end{aligned}$$

(i) The stress in each rod.

We know that,

$$\text{Strain in steel} = \text{Strain in copper}$$

or

$$\frac{\sigma_s}{E_s} = \frac{\sigma_c}{E_c}$$

$$\sigma_s = \frac{\sigma_c}{E_c} E_s = \frac{2 \times 10^5}{1 \times 10^5} \times \sigma_c = 2 \sigma_c \quad \dots(i)$$

$$\text{Now,} \quad \text{Stress} = \frac{\text{Load}}{\text{Area}} \quad \therefore \text{Load} = \text{Stress} \times \text{Area}$$

$$\text{Load on steel} + \text{Load on copper} = \text{Total Load}$$

$$\sigma_s \times A_s + \sigma_c \times A_c = P$$

$$2\sigma_c \times 314.16 + \sigma_c \times 314.16 = 45000$$

$$\sigma_c(2 \times 314.16 + 314.16) = 5000$$

$$942.48\sigma_c = 5000$$

$$\sigma_c = \frac{5000}{942.48} = 5.31 \text{ N/mm}^2.$$

Substituting the value of σ_c in equation (i), we get

$$\sigma_s = 2 \times 5.31 = 10.62 \text{ N/mm}^2.$$

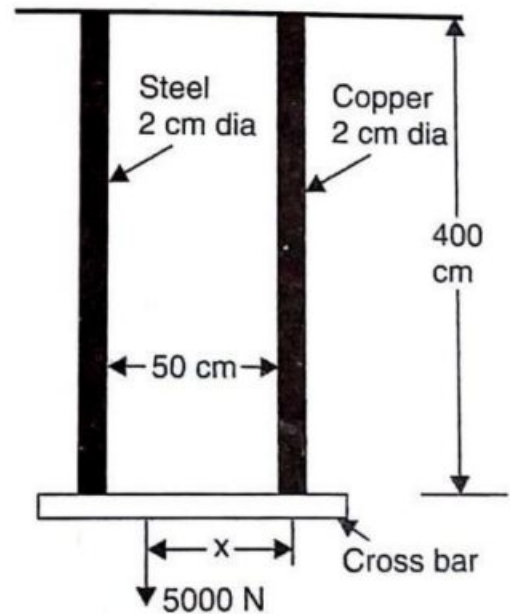

(ii) Position of the load of 5KN on cross bar

Let , X = The distance of 5 kN load from the copper rod

Now first calculate the load carried by each rod.

As $\text{Load} = \text{Stress} \times \text{Arca}$

$$\begin{aligned} \therefore \text{Load carried by steel rod, } P_s &= \sigma_s \times A_s \\ &= 10.62 \times 314.16 \\ &= \mathbf{3336.38 \text{ N.}} \end{aligned}$$

$$\begin{aligned} \text{Load Carried by copper rod, } P_c &= P - P_s \\ &= 5000 - 3336.38 \\ &= \mathbf{1663.62 \text{ N}} \end{aligned}$$

Now taking the moments about the copper road and equating the same, we get

$$\begin{aligned} 5000 \times X &= P_s \times 50 \\ &= 3336.38 \times 50 \end{aligned}$$

$$\begin{aligned} \therefore X &= \frac{3336.38 \times 50}{5000} \\ &= \mathbf{33.36 \text{ cm}} \text{ from the copper rod.} \end{aligned}$$

Problem 1.9. A load of 2MN is applied on a short concrete column 500mm × 500mm. The column is reinforced with four steel bars of 10mm diameter, one in each corner. Find the stresses in concrete and steel bars. Take E for steel as $2.1 \times 10^5 \text{ N/mm}^2$ and for concrete as $1.4 \times 10^4 \text{ N/mm}^2$.

Given Data:

- Load $P = 2 \text{ kN} = 2 \times 10^6 \text{ N}$
- Size of column = 500 mm × 500 mm
- Dia of steel rod = 10 mm
- No. of Steel bars = 4
- $E_s = 2.1 \times 10^5 \text{ N/mm}^2$
- $E_c = 1.4 \times 10^4 \text{ N/mm}^2$

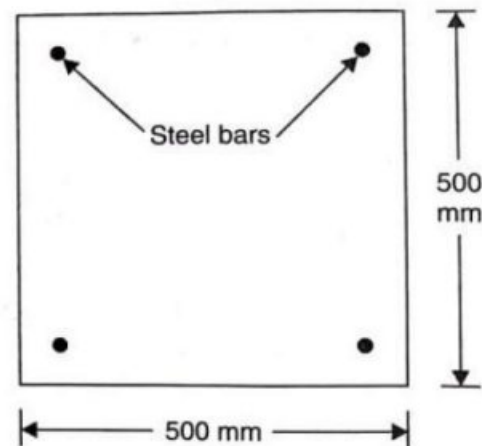

To find :

The stress in concrete and steel bars

STRENGTH OF MATERIALS

Solution:

$$\begin{aligned}
 \text{Area of steel bars}(A_s) &= 4 \times \frac{\pi D_s^2}{4} \\
 &= 4 \times \frac{\pi \times 20^2}{4} \\
 &= 314.16 \text{ mm}^2 \\
 \text{Area of column} &= 500 \times 500 = 250000 \text{ mm}^2 \\
 \text{Area of Concrete}(A_c) &= \text{Area of column} - \text{Area of steel bars} \\
 &= 250000 - 314.16 \\
 &= 249685.84 \text{ mm}^2
 \end{aligned}$$

We Know that,

$$\text{Strain in steel} = \text{Strain in concrete}$$

or
$$\frac{\sigma_s}{E_s} = \frac{\sigma_c}{E_c}$$

$$\sigma_s = \frac{\sigma_c}{E_c} E_s = \frac{2.1 \times 10^5}{1.4 \times 10^4} \times \sigma_c = 15 \sigma_c \quad \dots(i)$$

Now,
$$\text{Stress} = \frac{\text{Load}}{\text{Area}}$$

$$\therefore \text{Load} = \text{Stress} \times \text{Area}$$

$$\text{Load on steel} + \text{Load on concrete} = \text{Total Load}$$

$$\sigma_s \times A_s + \sigma_c \times A_c = P$$

or
$$15\sigma_c \times 314.16 + \sigma_c \times 249685.84 = 2 \times 10^6$$

$$\sigma_c(15 \times 314.16 + 249685.84) = 2 \times 10^6$$

$$254398.24 \sigma_c = 2 \times 10^6$$

$$\begin{aligned}
 \sigma_c &= \frac{2 \times 10^6}{254398.24} \\
 &= 7.86 \text{ N/mm}^2.
 \end{aligned}$$

Substituting the value of σ_c in equation (i), we get

$$\begin{aligned}
 \sigma_s &= 15 \times 7.86 \\
 &= 117.93 \text{ N/mm}^2.
 \end{aligned}$$

Problem1.10 A reinforced short concrete column 250 mm × 250mm in section is reinforced with 8 steel bars. The total area of steel bars is 2500 mm². The column carries a load of 390 kN. If the modulus of Elasticity for steel is 15 times that of concrete, find the stresses in concrete and steel.

Given Data:

Size of column	=	250 mm × 250mm
Load, P	=	390 kN= 390 × 10 ³ N
Area of steel, (As)	=	2500mm ²
No. of Steel bars	=	8
E _s	=	15 E _c

To find : The stress in concrete and steel bars

Solution:

Area of column	=	250 × 250= 62500 mm ²
Area of Concrete (Ac)	=	Area of column – Area of steel bars
	=	62500-2500
	=	60000mm ²

We Know that,

$$\text{Strain in steel} = \text{Strain in concrete}$$

or

$$\frac{\sigma_s}{E_s} = \frac{\sigma_c}{E_c}$$

$$\sigma_s = \frac{\sigma_c}{E_c} 15E_c = 15\sigma_c \quad \dots(i)$$

Now ,

$$\text{Stress} = \frac{\text{Load}}{\text{Area}} \quad \therefore \text{Load} = \text{Stress} \times \text{Area}$$

$$\text{Load on steel} + \text{Load on concrete} = \text{Total Load}$$

$$\sigma_s \times A_s + \sigma_c \times A_c = P$$

or

$$15\sigma_c \times 2500 + \sigma_c \times 60000 = 390 \times 10^3$$

$$\sigma_c (15 \times 2500 + 60000) = 390 \times 10^3$$

$$97500\sigma_c = 390 \times 10^3$$

$$\sigma_c = \frac{390 \times 10^3}{97500} = 4.0 \text{ N/mm}^2.$$

STRENGTH OF MATERIALS

Substituting the value of σ_c in equation (i), we get

$$\begin{aligned}\sigma_s &= 15 \times 4.0 \\ &= \mathbf{60.0 \text{ N/mm}^2}.\end{aligned}$$

Problem 1.11. A steel rod and two copper rods together support a load of 370 kN as shown in figure. The cross sectional area of steel rod is 2500 mm² and of each copper rod is 1600 mm². Find the stresses in the rods. Take E for steel = 2 × 10⁵ N/mm² and for copper = 1 × 10⁵ N/mm².

Given Data:

- P = 370 kN = 370000 N
- L_c = 15 cm = 150 mm
- L_s = 25 cm = 250 mm
- A_s = 2500 mm²
- A_c = 2 × 1600 = 3200 mm²
- E_s = 2 × 10⁵ N/mm²
- E_c = 1 × 10⁵ N/mm²

To find

The stresses in each rod

Solution:

We Know that,

Change in length of steel rod = Change in length of copper rod

or

$$\begin{aligned}\frac{\sigma_s}{E_s} L_s &= \frac{\sigma_c}{E_c} L_c \\ \sigma_s &= \frac{\sigma_c \times L_c \times E_s}{E_c \times L_s} \\ &= \frac{\sigma_c \times 150 \times 2 \times 10^5}{1 \times 10^5 \times 250} \times \sigma_c \\ &= 1.2 \sigma_c \quad \dots(i)\end{aligned}$$

Now , $\text{Stress} = \frac{\text{Load}}{\text{Area}} \quad \therefore \text{Load} = \text{Stress} \times \text{Area}$

Load on steel + Load on copper = Total Load

$$\sigma_s \times A_s + \sigma_c \times A_c = P$$

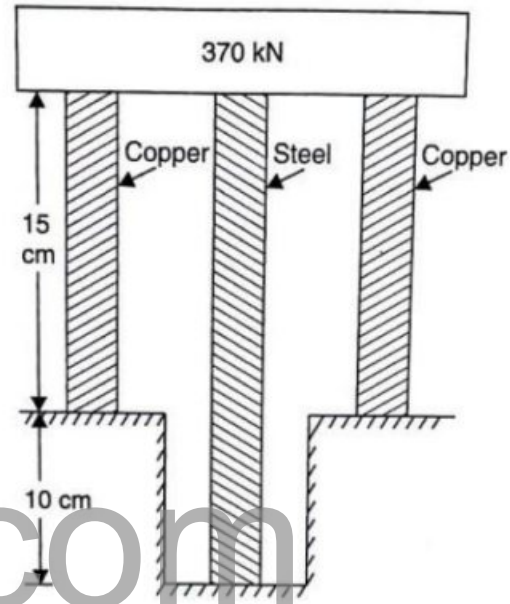

$$1.2\sigma_c \times 2500 + \sigma_c \times 3200 = 370000$$

$$\sigma_c(1.2 \times 2500 + 3200) = 370000$$

$$6200 \sigma_c = 370000$$

$$\sigma_c = \frac{370000}{6200} = 59.67 \text{ N/mm}^2.$$

Substituting the value of σ_c in equation (i), we get

$$\begin{aligned} \sigma_s &= 1.2 \times 59.67 \\ &= 71.604 \text{ N/mm}^2. \end{aligned}$$

Problem 1.12. Three bars made of copper, zinc and aluminium are of equal length and have cross-section 500, 750 and 1000 square mm respectively. They are rigidly connected at their ends. If the compound member is subjected to a longitudinal pull of 250 kN. Estimate the proportional of the load carried on each rod and the induced stresses. Take the value of E for copper = $1.3 \times 10^5 \text{ N/mm}^2$, for zinc = $1.0 \times 10^5 \text{ N/mm}^2$ and for aluminium = $0.8 \times 10^5 \text{ N/mm}^2$.

Given

$$A_c = 500 \text{ mm}^2$$

$$A_z = 750 \text{ mm}^2$$

$$A_a = 1000 \text{ mm}^2$$

$$P = 250 \text{ kN} = 250000 \text{ N}$$

$$E_c = 1.3 \times 10^5 \text{ N/mm}^2$$

$$E_z = 1.0 \times 10^5 \text{ N/mm}^2$$

$$E_a = 0.8 \times 10^5 \text{ N/mm}^2$$

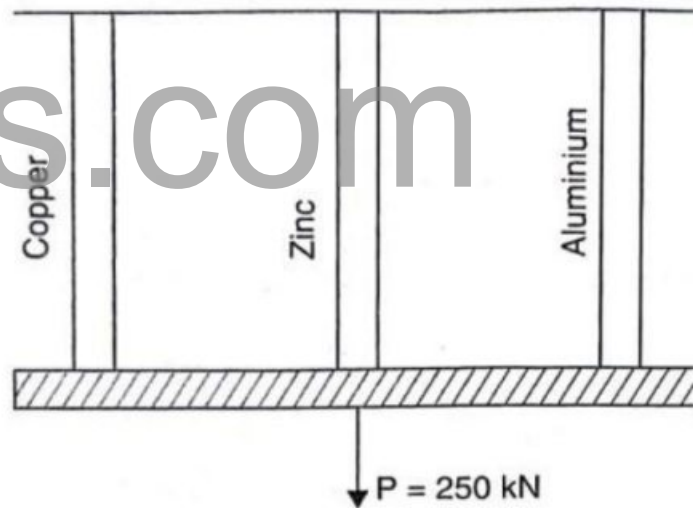

To find

- (i) The stress in the each rod and
- (ii) Load carried by each rod.

Solution:

(i) The stress in the rod and tube

We Know that,

$$\text{Strain in copper} = \text{Strain in zinc} = \text{Strain in aluminium}$$

STRENGTH OF MATERIALS

or
$$\frac{\sigma_c}{E_c} = \frac{\sigma_z}{E_z} = \frac{\sigma_a}{E_a}$$

$$\sigma_c = \frac{\sigma_a}{E_a} E_c = \frac{1.3 \times 10^5}{0.8 \times 10^5} \times \sigma_a = 1.625 \sigma_a \quad \dots(i)$$

Also,
$$\sigma_z = \frac{\sigma_a}{E_a} E_z = \frac{1.0 \times 10^5}{0.8 \times 10^5} \times \sigma_a = 1.25 \sigma_a \quad \dots(ii)$$

Now,
$$\text{Stress} = \frac{\text{Load}}{\text{Area}} \quad \therefore \text{Load} = \text{Stress} \times \text{Area}$$

Load on copper + Load on zinc + Load on aluminium = Total Load

$$\sigma_c \times A_c + \sigma_z \times A_z + \sigma_a \times A_a = P$$

or
$$1.625 \sigma_a \times 500 + 1.25 \sigma_a \times 750 + \sigma_a \times 1000 = 250000 \text{ N}$$

or
$$2750 \sigma_a = 250000$$

$$\sigma_a = \frac{250000}{2750}$$

$$= 90.9 \text{ N/mm}^2.$$

Substituting the value of σ_c in equation (i) and (ii) we get

$$\sigma_c = 1.625 \times 90.9 = 147.7 \text{ N/mm}^2.$$

and
$$\sigma_z = 1.25 \times 90.9 = 113.625 \text{ N/mm}^2.$$

(ii) Load carried by each bar

As
$$\text{Load} = \text{Stress} \times \text{Area}$$

Now,
$$\begin{aligned} \text{Load carried by copper rod, } P_c &= \sigma_c \times A_c \\ &= 147.7 \times 500 = 73850 \text{ N.} \end{aligned}$$

$$\begin{aligned} \text{Load carried by zinc rod, } P_z &= \sigma_z \times A_z \\ &= 113.625 \times 750 = 85218 \text{ N} \end{aligned}$$

$$\begin{aligned} \text{Load carried by aluminium rod, } P_a &= \sigma_a \times A_a \\ &= 90.9 \times 1000 = 90900 \text{ N} \end{aligned}$$

1.12 THERMAL STRESS AND STRAIN

When a material is free to expand or contract due to change in temperature, no stress and strain will be developed in the material. But when the material is rigidly fixed at both the ends, the change in length is prevented. Due to change in temperature, stress will be developed in the material. Such stress is known as thermal stress and the

corresponding strain is known as thermal strain. In other words, thermal stress is the stress developed in material due to change in temperature.

1.12.1. Determination of Thermal Stress and Strain

Consider a rod AB of length, fixed at both ends A and B as shown in figure. When the temperature of the rod is raised, it tends to expand by αTL . Where α is the coefficient of linear expansion.

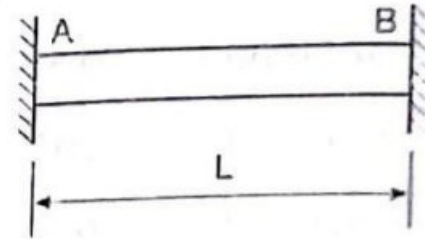

When the fixity at the end B is removed, the rod is freely expanded by αTL . From that we came to know $BB' = \alpha TL$.

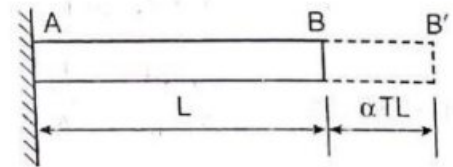

Compressive load P is applied at B', the rod is decreased in its length from $L + \alpha TL$ to L as shown in below figure.

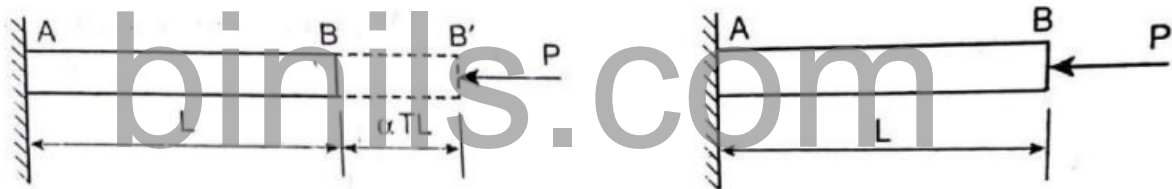

We Know that,

$$\begin{aligned} \text{Compressive strain or Thermal strain} &= \frac{\text{Decrease in Length}}{\text{Original length}} \\ &= \frac{\alpha TL}{L + \alpha TL} \\ &= \frac{\alpha TL}{L} \\ &= \alpha T \end{aligned}$$

$$\text{Thermal Strain} = \alpha T$$

We Know that,

$$\text{Young's Modulus, } E = \frac{\text{Stress}}{\text{Strain}}$$

$$\text{Stress} = \text{Strain} \times E$$

$$\text{Thermal Stress, } \sigma = \alpha TE$$

STRENGTH OF MATERIALS

We Know that,

$$\text{Stress} = \frac{\text{Load}}{\text{Area}}$$

Or

$$\text{Load} = \text{Stress} \times \text{Area}$$

$$\text{Load}(P) = \alpha TE \times A$$

Suppose a rod of length L, when subjected to a rise of temperature is permitted to expand only by Δ , then

$$\text{Thermal Strain} = \frac{\text{Actual expansion allowed}}{\text{Original length}}$$

$$= \frac{\alpha TL - \delta}{L}$$

$$\text{Thermal Stress} = \text{Thermal Strain} \times E$$

$$\sigma = \frac{(\alpha TL - \delta)}{L} \times E$$

1.13. THERMAL STRESSES IN COMPOSITE BARS

A composite member is composed of two or more different materials which are joined together. The following figure shows the composite bars consisting of brass and steel which are subjected to temperature variation. Due to different coefficient of linear expansion, the two materials (brass and steel) expand or contract by different amount.

When the ends of bars are rigidly fixed, then the composite section as a whole will expand or contract. Since the linear expansion of brass is more than that of steel, the brass will expand more than steel. So, the actual expansion of the composite bars will be less than that of brass. Therefore, brass will be subjected to compressive stress, whereas steel will be subjected to tensile stress.

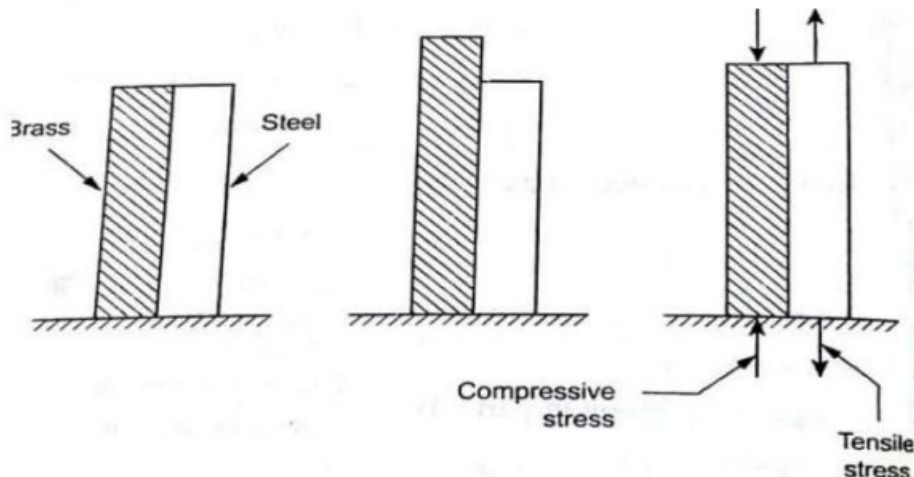

Let A_b be the Area of cross section of brass bar,

σ_b be the stress in brass bar,

e_b be the Strain in brass bar,

α_b be the Coefficient of linear expansion for brass bar,

E_b be the Young's modulus for brass bar.

A_s be the Area of the cross section of steel bar,

σ_s be the Stress in Steel bar,

e_s be the strain in Steel bar,

α_s be the Coefficient of linear expansion for steel bar,

and E_s be the Young's modulus for steel bar

We Know that,

$$\text{Stress in brass} = \frac{\text{Load on the brass}}{\text{Area of the brass}}$$

$$\text{Load on the brass}(P_b) = \text{Stress in Brass } (\sigma_b) \times \text{Area of the brass}(A_b)$$

Similarly,

$$\text{Load on the Steel } (P_s) = \text{Stress in Steel}(\sigma_s) \times \text{Area of the Steel } (A_s)$$

Under equilibrium condition, compression in the brass bar is equal to tension in the Steel bar

$$i.e., \text{ Load on the brass} = \text{Load on the steel}$$

$$\sigma_b A_b = \sigma_s A_s \quad \dots(i)$$

We know that,

$$\text{Actual expansion of steel} = \text{Actual expansion of brass} \quad \dots(ii)$$

$$\text{Actual expansion of steel} = \text{Free expansion of Steel} + \text{Expansion due to Tensile Stress in steel}$$

$$= \alpha_s TL + \frac{\sigma_s}{E_s} L \quad \dots (iii)$$

$$\left[\text{since } E = \frac{\sigma}{e} \text{ (or) } e = \frac{\sigma}{E} \right]$$

$$\text{Actual expansion of brass} = \text{Free expansion of brass} - \text{Contraction due to Compressive stress induced in brass}$$

$$= \alpha_b TL - \frac{\sigma_b L}{E_b} \quad \dots \text{(iv)}$$

Substituting equation (iii) and (iv) in equation (ii) we get,

$$\alpha_s TL + \frac{\sigma_s L}{E_s} = \alpha_b TL - \frac{\sigma_b L}{E_b}$$

Cancelling the L terms on both sides we get,

$$\alpha_s T + \frac{\sigma_s}{E_s} = \alpha_b T - \frac{\sigma_b}{E_b}$$

Problem 1.13 A steel rod of 30 mm diameter passes centrally through a copper tube of 60 mm external diameter and 50 mm internal diameter. The tube is closed at each end by rigid plates of negligible thickness. Calculate the stress developed by copper and steel when the temperature of the assembly is raised by 60°C. Take E for steel = 2×10^5 N/mm², E for copper = 1×10^5 N/mm², α for steel = $12 \times 10^{-6}/^\circ\text{C}$, α for copper = $18 \times 10^{-6}/^\circ\text{C}$.

Given Data:

Diameter of Steel rod $D_s = 30\text{mm}$

External diameter of copper, $D_c = 60\text{mm}$

Internal diameter of copper, $d_c = 50\text{mm}$

Rise in temperature, $T = 60^\circ\text{C}$

Young's modulus for steel $E_s = 2 \times 10^5$ N/mm²

Young's modulus for copper, $E_c = 1 \times 10^5$ N/mm²

Coefficient of linear expansion for Steel $\alpha_s = 12 \times 10^{-6} /^\circ\text{C}$,

Coefficient of linear expansion for copper $\alpha_c = 18 \times 10^{-6} /^\circ\text{C}$,

To find :

The Stress in steel and copper

Solution

$$\begin{aligned} \text{Area of steel rod} \quad (A_s) &= \frac{\pi D_s^2}{4} \\ &= \frac{\pi \times 30^2}{4} \\ &= 706.86 \text{ mm}^2 \end{aligned}$$

$$\text{Area of Copper tube} \quad (A_c) = \frac{\pi}{4} [D_c^2 - d_c^2]$$

$$= \frac{\pi}{4} [60^2 - 50^2] = 63.94 \text{mm}^2$$

Since the ends of the bars are rigidly fixed, the composite section as whole will expand or contract. In this problem, the coefficient of linear expansion of the copper is more than that of steel. So, the copper will expand more than steel, But the actual expansion of the composite bars will be less than that of copper. Therefore, copper will subjected to compressive stress, where as steel will be subjected to tensile stress

We Know that, Load on the Steel = Load on the Copper

$$\text{Or, } \sigma_s A_s = \sigma_c A_c \quad \dots(i)$$

$$\sigma_s \times 706.86 = \sigma_c \times 863.9$$

$$\sigma_s = \frac{\sigma_c \times 863.94}{706.86} = 1.22 \sigma_c \quad \dots(ii)$$

Also We know that,

Actual expansion of steel = Actual expansion of Copper

$$\text{Or } \alpha_s TL + \frac{\sigma_s L}{E_s} = \alpha_c TL - \frac{\sigma_c L}{E_c}$$

Cancelling the L terms on both sides we get,

$$\alpha_s T + \frac{\sigma_s}{E_s} = \alpha_c T - \frac{\sigma_c}{E_c}$$

$$\text{or, } (12 \times 10^{-6} \times 60) + \frac{1.22 \sigma_c}{2 \times 10^5} = (18 \times 10^{-6} \times 60) - \frac{\sigma_c}{1 \times 10^5}$$

$$\frac{1.22 \sigma_c}{2 \times 10^5} + \frac{\sigma_c}{1 \times 10^5} = (18 \times 10^{-6} \times 60) - (12 \times 10^{-6} \times 60)$$

$$1.61 \times 10^{-5} \sigma_c = 3.6 \times 10^{-4}$$

$$\sigma_c = \frac{3.6 \times 10^{-4}}{1.61 \times 10^{-5}}$$

$$\sigma_c = 22.36 \text{ N/mm}^2$$

Substituting the values of σ_c in equation ii we get,

$$\sigma_s = 1.22 \times 22.36$$

$$= 27.28 \text{ N/mm}^2$$

Problem 1.14. A gun metal rod 25 mm diameter screwed at the end passes through a steel tube 35 mm and 30mm external and internal diameters. The temperature of the whole

STRENGTH OF MATERIALS

assembly is raised to 125°C and the nuts on the rod are then screwed lightly home on the ends of the tube. Calculate the stresses developed in gun metal and steel tube when the temperature of the assembly has fallen to 20°C

Take E for gun metal = $1 \times 10^5 \text{ N/mm}^2$, E for steel = $2.1 \times 10^5 \text{ N/mm}^2$, α for gun metal = $20 \times 10^{-6}/^\circ\text{C}$, α for steel = $12 \times 10^{-6}/^\circ\text{C}$.

Given Data:

Diameter of gun metal rod (D_g) = 25 mm

External diameter of Steel, D_s = 35 mm

Internal diameter of Steel d_s = 30 mm

Fall in temperature, $T = 125^\circ\text{C} - 20^\circ\text{C} = 105^\circ\text{C}$

Young's modulus for gun metal, $E_g = 1 \times 10^5 \text{ N/mm}^2$

Young's modulus for Steel, $E_s = 2.1 \times 10^5 \text{ N/mm}^2$

Coefficient of linear expansion for Gun metal $\alpha_g = 20 \times 10^{-6}/^\circ\text{C}$,

Coefficient of linear expansion for steel $\alpha_s = 12 \times 10^{-6}/^\circ\text{C}$.

To find :

The Stress in steel and gun metal

Solution:

$$\begin{aligned} \text{Area of gun metal rod, } (A_g) &= \frac{\pi D_g^2}{4} \\ &= \frac{\pi \times 25^2}{4} = 490.87 \text{ mm}^2 \end{aligned}$$

$$\begin{aligned} \text{Area of steel tube, } (A_s) &= \frac{\pi}{4} [D_s^2 - d_s^2] \\ &= \frac{\pi}{4} [35^2 - 30^2] = 255.25 \text{ mm}^2 \end{aligned}$$

Coefficient of linear expansion of gun metal is more than that of steel. So, gun metal will be subjected to compressive stress whereas steel will be subjected to tensile stress.

We Know that, Load on the steel = Load on the gun metal

$$\text{Or, } \sigma_s A_s = \sigma_g A_g \quad \dots(i)$$

$$\sigma_s \times 255.25 = \sigma_g \times 490.87$$

$$\sigma_s = \frac{\sigma_g \times 490.87}{255.25} = 1.92\sigma_g \quad \dots(ii)$$

Also We know that,

Actual Contraction of steel = Actual Contraction of gun metal

$$\text{Or} \quad \alpha_s TL + \frac{\sigma_s}{E_s} L = \alpha_g TL - \frac{\sigma_g}{E_g} L$$

Cancelling the L terms on both sides we get,

$$\alpha_s T + \frac{\sigma_s}{E_s} = \alpha_g T - \frac{\sigma_g}{E_g}$$

$$\text{or,} \quad (12 \times 10^{-6} \times 105) + \frac{1.92\sigma_g}{2.1 \times 10^5} = (20 \times 10^{-6} \times 105) - \frac{\sigma_g}{1 \times 10^5}$$

$$\frac{1.92\sigma_g}{2.1 \times 10^5} + \frac{\sigma_g}{1 \times 10^5} = (20 \times 10^{-6} \times 105) - (12 \times 10^{-6} \times 105)$$

$$19.1 \times 10^{-6} \sigma_g = 0.84 \times 10^{-3}$$

$$\sigma_g = \frac{0.84 \times 10^{-3}}{19.1 \times 10^{-6}} = 43.97 \text{ N/mm}^2.$$

Substituting the values of σ_g in equation (ii) we get,

$$\sigma_s = 1.92 \times 43.97 = 84.42 \text{ N/mm}^2.$$

Problem 1.15. A composite bar is made with a copper flat of size 50mm × 30mm and steel flat of 50mm × 40mm of length 500mm each placed one over the other. Find the stress induced in the material, when the composite bar is subjected to an increase in temperature of 90°C. Take coefficient of thermal expansion of steel as $12 \times 10^{-6}/^\circ\text{C}$ and that of copper as $18 \times 10^{-6}/^\circ\text{C}$, Modulus of Elasticity of steel = 200Gpa and modulus of Elasticity of copper = 100Gpa.

Given Data:

$$\text{Area of copper,} \quad A_c = 50 \times 30 = 1500 \text{ mm}^2$$

$$\text{Area of steel,} \quad A_s = 50 \times 40 = 2000 \text{ mm}^2$$

$$\text{Length of the flat} \quad (L) = 500 \text{ mm}$$

$$\text{Rise in temperature,} \quad T = 90^\circ\text{C}$$

$$\text{Coefficient of linear expansion for Copper } \alpha_c = 18 \times 10^{-6}/^\circ\text{C},$$

$$\text{Coefficient of linear expansion for Steel } \alpha_s = 12 \times 10^{-6}/^\circ\text{C}.$$

STRENGTH OF MATERIALS

Young's modulus for steel $E_s = 200 \text{ Gpa} = 200 \times 10^9 \text{ Pa}$
 $= 200 \times 10^9 \text{ N/m}^2 = 200 \times \frac{10^9}{10^6} = 200 \times 10^3 \text{ N/mm}^2$

Young's modulus for copper $E_c = 100 \text{ Gpa} = 100 \times 10^9 \text{ Pa}$
 $= 100 \times 10^9 \text{ N/m}^2 = 100 \times \frac{10^9}{10^6} = 100 \times 10^3 \text{ N/mm}^2$

To find : The Stress induced in the material

Solution:

Coefficient of linear expansion of gun metal is more than that of steel. So, gun metal will be subjected to compressive stress whereas steel will be subjected to tensile stress.

Wkt, Load on the steel = Load on the copper

Or, $\sigma_s A_s = \sigma_c A_c \quad \dots(i)$

$$\sigma_s \times 2000 = \sigma_c \times 1500$$

$$\sigma_s = \frac{\sigma_c \times 1500}{2000} = 0.75 \sigma_c \quad \dots(ii)$$

Also We know that,

Actual Expansion of steel = Actual Expansion of copper

Or $\alpha_s T L + \frac{\sigma_s}{E_s} L = \alpha_c T L - \frac{\sigma_c}{E_c} L$

Cancelling the L terms on both sides we get,

$$\alpha_s T + \frac{\sigma_s}{E_s} = \alpha_c T - \frac{\sigma_c}{E_c}$$

or, $(12 \times 10^{-6} \times 90) + \frac{0.75 \sigma_c}{200 \times 10^3} = (18 \times 10^{-6} \times 90) - \frac{\sigma_c}{100 \times 10^3}$

$$\frac{0.75 \sigma_c}{200 \times 10^3} + \frac{\sigma_c}{100 \times 10^3} = (18 \times 10^{-6} \times 90) - (12 \times 10^{-6} \times 90)$$

$$1.375 \times 10^{-5} \sigma_c = 5.4 \times 10^{-4}$$

$$\sigma_c = \frac{5.4 \times 10^{-4}}{1.375 \times 10^{-5}} = 39.27 \text{ N/mm}^2.$$

Substituting the values of σ_c in equation ii we get,

$$\sigma_s = 0.75 \times 39.27 = 29.45 \text{ N/mm}^2.$$

1.14. LONGITUDINAL STRAIN

When a body is subjected to an axial tensile or compressive load, there is an axial deformation in the length of the body. The ratio of axial deformation to the original length of the body is known as longitudinal strain or linear strain. The longitudinal strain is also defined as the deformation of the body per unit length in the direction of the applied load.

Let L = length of the body,

P = Tensile force acting on the body,

δL = Increase in the length of the body in the direction of load P ,

Then, longitudinal strain = $\frac{\delta L}{L}$

1.15. LATERAL STRAIN

The strain at right angles to the direction of applied load is known as lateral strain. Let a rectangular bar of length L , breadth b and depth d is subjected to an axial tensile load P as shown in fig. The length of the bar will increase while the breadth and depth will decrease.

Let δL = Increase in length,

δb = Decrease in breadth and

δd = Decrease in depth.

Then longitudinal strain = $\frac{\delta L}{L}$ and

lateral strain = $\frac{\delta b}{b}$ or $\frac{\delta d}{d}$

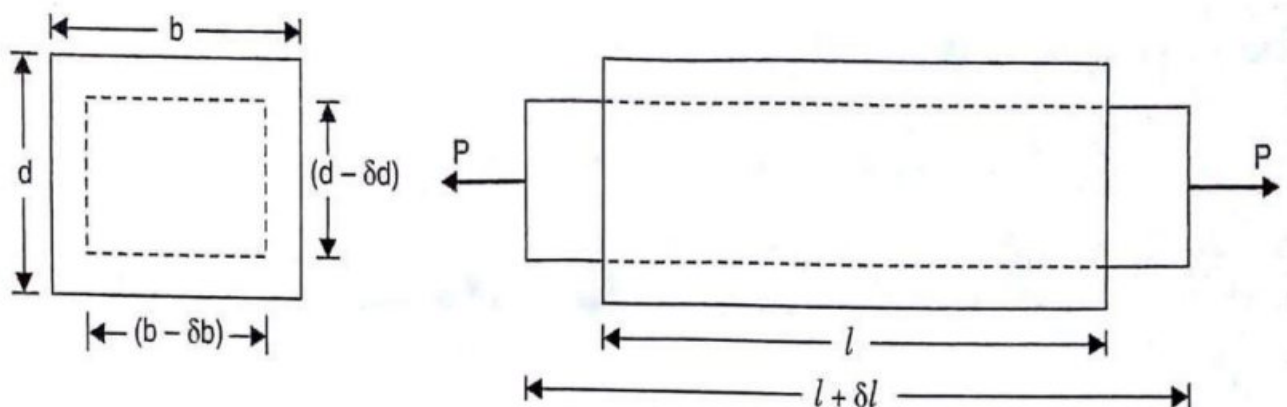

1.16. ELASTIC CONSTANTS:

There are three types of elastic constants. They are

1. Modulus of Elasticity or Young's Modulus (E),
2. Shear Modulus or Modulus of Rigidity (C) or G or (N) and
3. Bulk Modulus (K)

1.17. MODULUS OF ELASTICITY OR YOUNG'S MODULUS:

The ratio of linear stress (tensile or compressive) to the corresponding linear strain is a constant. This ratio is known as Young's Modulus or Modulus of Elasticity and is denoted by E.

$$E = \frac{\text{Linear stress}(\sigma)}{\text{Linear strain}(e)}$$

1.18. MODULUS OF RIGIDITY OR SHEAR MODULUS:

The ratio of shear stress to the corresponding shear strain within the elastic limit, is known as Modulus of Rigidity or Shear Modulus. This is denoted by C or G or N.

$$C \text{ or } G \text{ or } N = \frac{\text{Shear stress}(\tau)}{\text{Shear strain}(\theta)}$$

1.19. BULK MODULUS:

When a body is subjected to the mutually perpendicular like and equal direct stresses, the ratio of direct stress to the corresponding volumetric strain is found to be constant for a given material when the deformation is within a certain limit. This ratio is known as bulk modulus and is usually denoted by K. Mathematically bulk modulus is given by

$$K = \frac{\text{Direct stress}}{\text{Volumetric Strain}} = \frac{\sigma}{\left(\frac{\delta V}{V}\right)}$$

1.20. POISSON'S RATIO:

The ratio of lateral strain to the longitudinal strain is a constant for a given material, when the material is stressed within the elastic limit. This ratio is called Poisson's Ratio.

$$\text{Poisson's ratio, } (\mu) = \frac{\text{Lateral Strain}}{\text{Linear Strain}}$$

$$\text{Lateral strain} = \mu \times \text{Linear strain}$$

The value of Poisson's ratio varies from 0.25 to 0.33. For rubber, its value ranges from 0.45 to 0.50

Problem 1.16. Determine the changes in length, breadth and thickness of a steel bar which is 4 m long, 30 mm wide and 20 mm thick and is subjected to an axial pull of 30 kN in the direction of its length. Take $E = 2 \times 10^5 \text{ N/mm}^2$ and Poisson's ratio = 0.3

Given Data

Length of the bar,	$L = 4\text{m} = 4000\text{mm}$
Breadth of the bar,	$b = 30\text{mm}$
Thickness of the bar,	$t = 20\text{mm}$
Axial, pull	$P = 30\text{kN} = 30000\text{N}$
Young's Modulus	$E = 2 \times 10^5 \text{ N/mm}^2$
Poisson's ratio	$\mu = 0.3$

To Find

The changes in length, changes in breadth and changes in thickness.

Solution

$$\begin{aligned} \text{Stress} &= \frac{\text{Load}}{\text{Area}} \\ \text{Area} &= b \times t = 30 \times 20 = 600\text{mm}^2 \\ \text{Stress} &(\sigma) = \frac{30000}{600} = 50 \text{ N/mm}^2 \end{aligned}$$

We know that,

$$\begin{aligned} \text{Young's Modulus} &= \frac{\text{Stress}}{\text{Strain}} \\ \text{Strain} &(e) = \frac{\text{Stress}}{\text{Young's Modulus}} = \frac{50}{2 \times 10^5} = 2.5 \times 10^{-4} \end{aligned}$$

Changes in length (δL)

$$\begin{aligned} \text{Strain (e)} &= \frac{\delta L}{L} \\ \delta L &= L \times e \\ &= 4000 \times 2.5 \times 10^{-4} = \mathbf{1.0\text{mm}} \end{aligned}$$

STRENGTH OF MATERIALS

Changes in breadth (δb)

We know that,

$$\begin{aligned} \text{Poisson's ratio } (\mu) &= \frac{\text{Lateral Strain}}{\text{Linear Strain}} \\ \text{Lateral strain} &= \text{Linear strain} \times \text{Poisson's Ratio} \\ &= 2.5 \times 10^{-4} \times 0.3 = 7.5 \times 10^{-5} \\ \text{Lateral Strain} &= \frac{\text{Change in breadth}}{\text{Original breadth}} \\ \text{Changes in breadth } (\delta b) &= b \times \text{lateral strain} \\ &= 30 \times 7.5 \times 10^{-5} = \mathbf{0.00225\text{mm}} \end{aligned}$$

Changes in thickness (δt)

$$\begin{aligned} \text{Lateral Strain} &= \frac{\text{Change in thickness}}{\text{Original thickness}} \\ \text{Changes in thickness } (\delta t) &= t \times \text{lateral strain} \\ &= 20 \times 7.5 \times 10^{-5} \\ &= \mathbf{0.0015\text{mm}} \end{aligned}$$

Problem.1.17. Determine the value of Young's Modulus and poisson's ratio of a metallic bar of length 30cm, breadth 4cm and depth 4cm when the bar is subjected to an axial compressive load of 400KN. The decrease in length is given as 0.075cm and increase in breadth is 0.003cm

Given Data

Length of the bar,	$L=30\text{cm} = 300\text{mm}$
Breadth of the bar,	$b=4\text{cm} = 40\text{mm}$
Thickness of the bar,	$t= 4\text{cm}=40\text{mm}$
Compressive Load	$P= 400\text{KN} = 400000\text{N}$
Decrease in length	$(\delta L) = 0.075\text{cm} = 0.75\text{mm}$
Increase in breadth	$(\delta b) = 0.003\text{cm} = 0.03\text{mm}$

To Find

The Young's Modulus and Poisson's ratio.

Solution

Young's Modulus

We Know that,

$$\text{Stress} = \frac{\text{Load}}{\text{Area}}$$

$$\text{Area} = b \times t = 40 \times 40 = 1600 \text{mm}^2$$

$$\text{Stress}(\sigma) = \frac{400000}{1600} = 250 \text{N/mm}^2$$

Also,

$$\text{Strain}(\epsilon) = \frac{\delta L}{L} = \frac{0.75}{300} = 2.5 \times 10^{-3}$$

$$\text{Young's Modulus} = \frac{\text{Stress}}{\text{Strain}} = \frac{250}{2.5 \times 10^{-3}} = 1 \times 10^5 \text{N/mm}^2.$$

Poisson's ratio (μ)

We know that, $\text{Poisson's ratio } (\mu) = \frac{\text{Lateral Strain}}{\text{Linear Strain}}$

$$\text{Lateral Strain} = \frac{\text{Change in breadth}}{\text{Original breadth}} = \frac{0.03}{40} = 7.5 \times 10^{-4}$$

$$\therefore \text{Poisson's ratio } (\mu) = \frac{7.5 \times 10^{-4}}{2.5 \times 10^{-3}} = 0.3$$

Problem 1.18. A steel bar 300 mm long, 50mm wide and 40mm thick is subjected to a pull of 300kN in the direction of its length. Determine the change in volume. Take $E=2 \times 10^5 \text{N/mm}^2$ and $\mu = 0.25$

Given Data

Length of the bar,	$L=300\text{mm}$
Breadth of the bar,	$b=50\text{mm}$
Thickness of the bar,	$t= 40\text{mm}$
Pull	$P= 300\text{KN} =300000\text{N}$
Young's Modulus	$E=2 \times 10^5 \text{ N/mm}^2$
Poisson's ratio	$\mu = 0.25$

To Find

The changes in volume (δv).

Solution

$$\text{Original Volume}(V) = L \times b \times t$$

$$= 300 \times 50 \times 40 = 600000 \text{mm}^3.$$

$$\text{Linear strain} \left(\frac{dL}{L} \right) = \frac{\text{Stress}}{\text{Young's Modulus}}$$

$$\text{Stress} = \frac{\text{Load}}{\text{Area}} = \frac{300000}{(50 \times 40)} = 150 \text{ N/mm}^2.$$

$$\frac{dL}{L} = \frac{150}{2 \times 10^5} = 0.00075$$

Now, Volumetric strain given by Rectangular bar

$$e_v = \frac{dL}{L} \times (1 - 2\mu)$$

$$= 0.00075 \times (1 - 2 \times 0.25) = 0.000375$$

$$e_v = \frac{dV}{V}$$

$$dV = e_v \times v$$

$$= 0.000375 \times 600000$$

$$= 225 \text{mm}^3$$

Problem 1.19. A metallic bar $250 \text{mm} \times 100 \text{mm} \times 50 \text{mm}$ is loaded as shown in Figure. Find the change in volume. Take $E = 2 \times 10^5 \text{N/mm}^2$ and poisson's ratio = 0.25

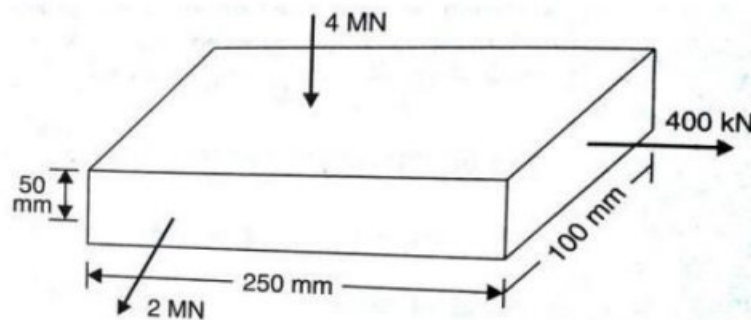

$$\text{Stress in X-direction } (\sigma_x) = \frac{\text{Load in x-direction}}{\text{Area of cross section}} = \frac{\text{Load in x-direction}}{y \times z}$$

$$= \frac{400000}{100 \times 50} = 80 \text{N/mm}^2 \text{ (tension)}$$

$$\text{Similarly, } \sigma_y = \frac{\text{Load in y-direction}}{x \times z}$$

$$= \frac{2000000}{250 \times 50} = 160 \text{N/mm}^2 \text{ (tensile)}$$

and

$$\sigma_z = \frac{\text{Load in z-direction}}{x \times y}$$

$$= \frac{4000000}{250 \times 100} = 160 \text{N/mm}^2 \text{ (compression)}$$

Volumetric Strain of a Rectangular bar subjected to three forces which are mutually perpendicular

$$e_v = \frac{1}{E}(\sigma_x + \sigma_y + \sigma_z)(1 - 2\mu)$$

$$\frac{dv}{v} = \frac{1}{2 \times 10^5} (80 + 160 - 160)(1 - 2 \times 0.25)$$

$$= 0.0002$$

∴ change in volume,

$$dv = 0.0002 \times v$$

$$= 0.0002 \times 250 \times 100 \times 50$$

$$= 250 \text{mm}^3.$$

1.21. RELATIONSHIP BETWEEN MODULUS OF ELASTICITY (E) AND MODULUS OF RIGIDITY (C)

Consider a cube of length L subjected to a shear stress of (τ) shown in Fig. Due to their stresses, the cube will be subjected to a deformation in such a way that the diagonal BD is elongated and the diagonal (AC) will be shortened. Let this shear stress (τ) cause shear strain (ϕ) as shown in Fig.

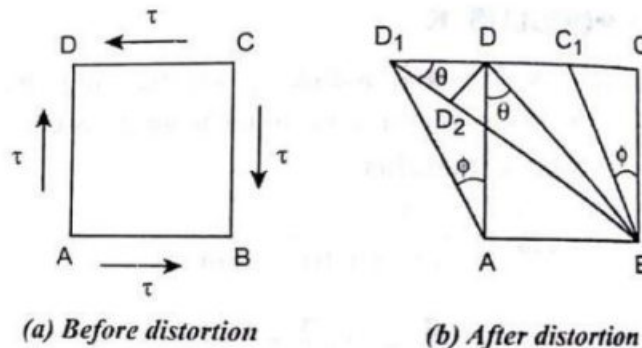

$$\text{Longitudinal strain (e)} = \frac{\text{Change in length}}{\text{Original length}}$$

$$\begin{aligned}
 &= \frac{BD1-BD}{BD} \\
 &= \frac{D1D2}{BD} \\
 &= \frac{DD1 \cos 45^\circ}{BD} \quad \left[\text{since } \cos 45^\circ = \frac{D1D2}{D1D} \right] \\
 &= \frac{DD1 \cos 45^\circ}{\frac{AD}{\cos 45^\circ}} \\
 &= \frac{DD1 \cos 45^\circ}{\frac{AD}{\frac{1}{\sqrt{2}}}} = \frac{DD1 \cos 45^\circ}{AD\sqrt{2}} \quad \left[\text{since } \cos 45^\circ = \frac{AD}{BD} \right] \\
 &= \frac{DD1}{AD\sqrt{2} \times 2} \\
 e &= \frac{DD1}{2AD} \quad \dots(i)
 \end{aligned}$$

We know that,

$$\begin{aligned}
 \tan \phi &= \frac{DD1}{AD} \\
 \phi &= \frac{DD1}{AD} \quad (\text{since } \phi \text{ is very small})
 \end{aligned}$$

Substituting the value of ϕ in equation (i) we get,

$$\text{Longitudinal strain } e = \frac{\phi}{2} \quad \dots(ii)$$

From that we know, Longitudinal strain of the diagonal BD is half of the shear strain

$$\text{Modulus of rigidity, } C = \frac{\text{shearing stress}(\tau)}{\text{shearing strain}(\phi)}$$

$$\text{Or, } \phi = \frac{\tau}{c}$$

Substituting the value of ϕ in equation ii we get,

$$\text{Linear strain, } e = \frac{\tau}{2c} \quad \dots(iii)$$

Tensile strain on the diagonal BD is due to tensile stress and is given by Young's modulus,

$$\text{Young's modulus, } E = \frac{\text{Tensile Stress}}{\text{Tensile Strain}}$$

$$E = \frac{\tau}{e}$$

$$\text{Tensile strain (e)} = \frac{\tau}{E}$$

Tensile strain on the diagonal BD is due to compressive stress on the diagonal AC which is given by Poisson's ratio.

$$\text{Poisson's Ratio, } \mu = \frac{\text{Lateral strain}}{\text{Longitudinal strain or Tensile strain}}$$

$$\text{Lateral strain} = \text{Poisson ratio} \times \text{Tensile strain}$$

$$\text{Lateral strain, } e_{\text{lat}} = \mu \times \frac{\tau}{E}$$

$$\text{Total strain} = \text{Linear strain} + \text{Lateral strain}$$

$$= \frac{\tau}{E} + \mu \times \frac{\tau}{E}$$

$$\text{Total strain} = \frac{\tau}{E} (1 + \mu) \quad \dots(\text{iv})$$

Equating equation (iii) & (iv) we get,

$$\frac{\tau}{2C} = \frac{\tau}{E} (1 + \mu)$$

$$\frac{\tau}{2C} = \frac{1}{E} (1 + \mu)$$

$$E = 2C(1 + \mu)$$

1.22. RELATION BETWEEN BULK MODULUS (K) AND YOUNG'S MODULUS (E)

Consider a cube ABCDEFGH subjected to three mutually perpendicular tensile stresses of equal intensity as shown in Figure

Let,

σ = Stress on each face

E = Young's modulus

K = Bulk modulus

$\frac{1}{m}$ or μ = Poisson's ratio

L = Length

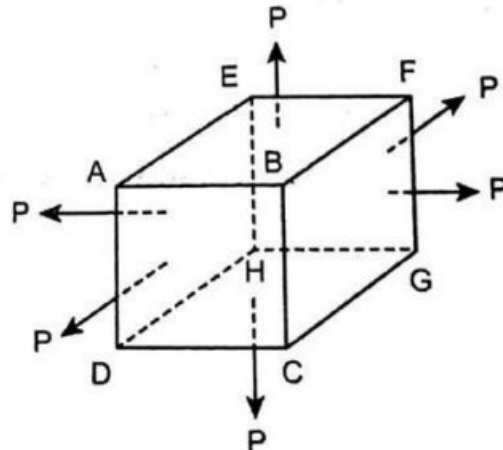

Now consider the deformation of one side (AB) of cube under the action of three mutually perpendicular stresses. This side will suffer the following three strains.

1. Tensile strain of AB is equal to $\frac{\sigma}{E}$ due to stresses on the faces AEHD and BFGC.

$$\text{Young's modulus, } E = \frac{\text{Tensile Stress}}{\text{Tensile Strain}}$$

$$E = \frac{\sigma}{e}$$

$$\text{Tensile strain (e)} = \frac{\sigma}{E}$$

2. Compressive lateral strain of AB is equal to $\mu \times \frac{\sigma}{E}$ due to stresses on the faces AEFB and DHGC.

$$\text{Poisson's Ratio, } \mu = \frac{\text{Lateral strain}}{\text{Longitudinal strain or Tensile strain}}$$

$$\text{Lateral strain} = \text{Poisson ratio} \times \text{Tensile strain}$$

$$\text{Lateral strain, } e_{\text{lat}} = \mu \times \frac{\sigma}{E}$$

3. Compressive lateral strain of AB is equal to $\mu \times \frac{\sigma}{E}$ due to stresses on the faces ABCD and EFGH,

Total Strain of AB is given by,

$$\frac{dL}{L} = \frac{\sigma}{E} - \mu \frac{\sigma}{E} - \mu \frac{\sigma}{E}$$

$$\frac{dL}{L} = \frac{\sigma}{E} (1 - \mu - \mu)$$

$$= \frac{\sigma}{E} (1 - 2\mu)$$

$$\frac{dL}{L} = \frac{\sigma}{E} (1 - 2\mu)$$

We know that, original volume of cube $V = L^3$

Differentiating with respect to L,

$$dV = 3L^2 dL$$

$$\frac{dV}{V} = \frac{3L^2 dL}{V}$$

$$\frac{dV}{V} = \frac{3L^2 dL}{L^3}$$

$$\frac{dV}{V} = \frac{3dL}{L}$$

Substituting dL/L value We get

$$\frac{dV}{V} = 3 \left[\frac{\sigma}{E} (1 - 2\mu) \right]$$

We know that,

$$\text{Bulk Modulus (K)} = \frac{\text{Direct Stress}}{\text{Volumetric strain}} = \frac{\sigma}{\frac{dV}{V}}$$

$$= \frac{\sigma}{\frac{3\sigma}{E}(1-2\mu)}$$

$$K = \frac{E}{3(1-2\mu)}$$

$$E = 3K(1-2\mu)$$

Problem 1.20. A bar of 30mm diameter is subjected to a pull of 60KN. The measured extension on gauge length of 200mm is 0.1mm and change in diameter is 0.004mm. Calculate the Young's modulus, Poisson's ratio, Shear modulus and Bulk Modulus.

Given Data

Diameter of the bar,	$d=30\text{mm}$
Pull	$P=60\text{KN}=60000\text{N}$
Length of the bar,	$L=200\text{mm}$
Extension in length	$(\delta L) = 0.1\text{mm}$
Changes in diameter	$(\delta d) = 0.004\text{mm}$

To Find

The Young's Modulus, Poisson's ratio, Shear modulus and Bulk Modulus.

Solution

Young's Modulus

We Know that, $\text{Stress} = \frac{\text{Load}}{\text{Area}}$

$$\text{Area} = \frac{\pi}{4} d^2 = \frac{\pi}{4} 30^2 = 706.86\text{mm}^2$$

$$\text{Stress}(\sigma) = \frac{60000}{706.86} = 84.88 \text{ N/mm}^2$$

Also,
$$\text{Strain}(e) = \frac{\delta L}{L} = \frac{0.1}{200} = 0.0005$$

$$\text{Young's Modulus} = \frac{\text{Stress}}{\text{Strain}} = \frac{84.88}{0.0005} = 1.6976 \times 10^5 \text{ N/mm}^2.$$

Poisson's ratio (μ)

We know that,
$$\text{Poisson's ratio } (\mu) = \frac{\text{Lateral Strain}}{\text{Linear Strain}}$$

$$\text{Lateral Strain} = \frac{\text{Change in diameter}}{\text{Original diameter}} = \frac{0.004}{30} = 0.00013$$

$$\therefore \text{Poisson's ratio } (\mu) = \frac{0.00013}{0.0005} = 0.27$$

Shear Modulus(C)

We Know that ,
$$E = 2C(1+\mu)$$

Or
$$C = \frac{E}{2(1+\mu)}$$

$$= \frac{1.6976 \times 10^5}{2 \times (1+0.27)} = 66.835 \times 10^3 \text{ N/mm}^2.$$

Bulk Modulus (K)

We Know that,
$$E = 3K(1-2\mu)$$

Or
$$K = \frac{E}{3 \times (1-2\mu)}$$

$$= \frac{1.6976 \times 10^5}{3 \times (1-2 \times 0.27)}$$

$$= 1.230 \times 10^5 \text{ N/mm}^2.$$

1.23. PRINCIPAL PLANES AND PRINCIPAL STRESSES

The planes, which have no shear stress are known as principal planes. Hence principal planes are the planes of zero shear stress. These planes carry only normal stresses.

The normal stresses acting on a principal plane, are known as principal stresses.

1.24. METHODS FOR DETERMINING STRESSES ON OBLIQUE SECTION

The stresses on oblique section are determined by the following methods:

1. Analytical method and 2. Graphical method.

1.25. ANALYTICAL METHOD FOR DETERMINING STRESSES ON OBLIQUE SECTION

The following two cases will be considered for determining stresses on oblique plane.

1. A member subjected to a direct stress in one plane.
2. The member is subjected to like direct stresses in two mutually perpendicular directions.

1.25.1 A Member subjected to a Direct stress in one plane.

Figure shows a rectangular member of uniform cross sectional area A and of unit thickness

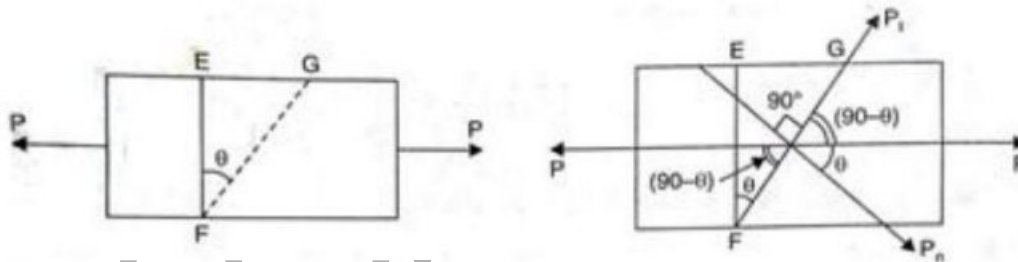

Let P = Axial force acting on the member

A = Area of cross section, which is perpendicular to the line of action of the force P .

The stress acting along X axis, $\sigma = \frac{P}{A}$

Hence, the member is subjected to a stress along X axis.

Consider a cross section EF which is perpendicular to the line of action of the force P .

Then the area of section, $EF = EF \times 1 = A$

The stress on the section EF is given by

$$\sigma = \frac{\text{Force}}{\text{Area of } EF} = \frac{P}{A}$$

The stress on the section EF is entirely normal stress. There is no shear stress (or tangential stress) on the section EF .

Now consider a section FG at an angle θ with the normal cross section EF as shown in Figure

$$\text{Area of } FG = FG \times 1 = FG$$

$$= \frac{EF}{\cos\theta} \times 1 \quad (\text{since In } \triangle EFG, \theta = \frac{EF}{FG} \therefore FG = \frac{EF}{\cos\theta})$$

$$= \frac{A}{\cos\theta}$$

$$\therefore \text{Stress on the section, FG} = \frac{\text{Force}}{\text{Area of section FG}} = \frac{P}{\frac{A}{\cos\theta}} = \frac{P}{A} \cos\theta$$

$$= \sigma \cos\theta \quad (\text{since } \sigma = \frac{P}{A}) \quad \dots(i)$$

This stress on the section FG, is parallel to the axis of the member (i.e., this stress is along X axis). This stress may be resolved in two components. One component will be normal to the section FG whereas the second component will be along the section FG (i.e., tangential stress on the section FG). The normal stress and tangential stress (i.e., shear stress) on the section FG are obtained as given below. (Refer above Fig.)

Let P_n = The component of the force P, normal to section FG = $P \cos\theta$

P_t = The component of force P, along the section FG (or tangential to the surface FG) = $P \sin\theta$

σ_n = Normal stress across the section FG

σ_t = Tangential stress (i.e., shear stress) across the section FG.

$$\text{Normal stress } \sigma_n = \frac{\text{Force normal to section FG}}{\text{Area of section FG}}$$

$$= \frac{P_n}{\frac{A}{\cos\theta}} \quad (\text{since } P_n = P \cos\theta)$$

$$= \frac{P \cos\theta}{\frac{A}{\cos\theta}}$$

$$= \frac{P}{A} \cos\theta \cdot \cos\theta = \frac{P}{A} \cos^2\theta$$

$$= \sigma \cos^2\theta \quad \dots(ii) \quad \text{Tangential stress(or)}$$

Shear stress,

$$\sigma_t = \frac{\text{Tangential force across section FG}}{\text{Area of section FG}}$$

$$= \frac{P_t}{\frac{A}{\cos\theta}} \quad (\text{since } P_t = P \sin\theta)$$

$$= \frac{P \sin\theta}{\frac{A}{\cos\theta}}$$

$$= \frac{P}{A} \sin\theta \cdot \cos\theta = \sigma \sin\theta \cdot \cos\theta$$

$$= \frac{\sigma}{2} \sin 2\theta \quad \dots \text{(iii)}$$

$$[\because \text{since } \sin 2\theta = 2 \sin \theta \cos \theta \quad \sin \theta \cos \theta = \sin 2\theta / 2]$$

From equation (ii) it is seen that the normal stress (σ_n) on the section FG will be maximum when $\cos^2 \theta$ or $\cos \theta$ is maximum. And $\cos \theta$ will be maximum when $\theta = 0^\circ$ as $\cos 0 = 1$. But when $\theta = 0^\circ$, the section FG will coincide with section EF. But the section EF is normal to the line of action of the loading. This means the plane normal to the axis of loading. This means the plane normal to the axis of loading will carry the maximum normal stress.

$$\therefore \text{Maximum normal stress, } = \sigma \cos^2 \theta = \sigma \cos^2 0 = \sigma \quad \dots \text{(iv)}$$

From equation (iii), it is observed that the tangential stress (i.e., shear stress) across the section FG will be maximum when $\sin 2\theta = 1$ or $2\theta = 90^\circ$ or 270°

$$\text{or } \theta = 45^\circ \text{ or } 135^\circ$$

This means the shear stress will be maximum on two planes inclined at 45° and 135° to the normal section EF as shown in fig.

$$\therefore \text{Max. value of shear stress } = \frac{\sigma}{2} \sin 2\theta = \frac{\sigma}{2} \sin 90^\circ = \frac{\sigma}{2} \quad \dots \text{(v)}$$

From equations (iv) and (v) it is seen that maximum normal stress is equal to σ Whereas the maximum shear stress is equal to $\frac{\sigma}{2}$ or equal to half the value of greatest normal stress.

1.25.2.A member subjected to like Direct stresses in two mutually perpendicular Directions.

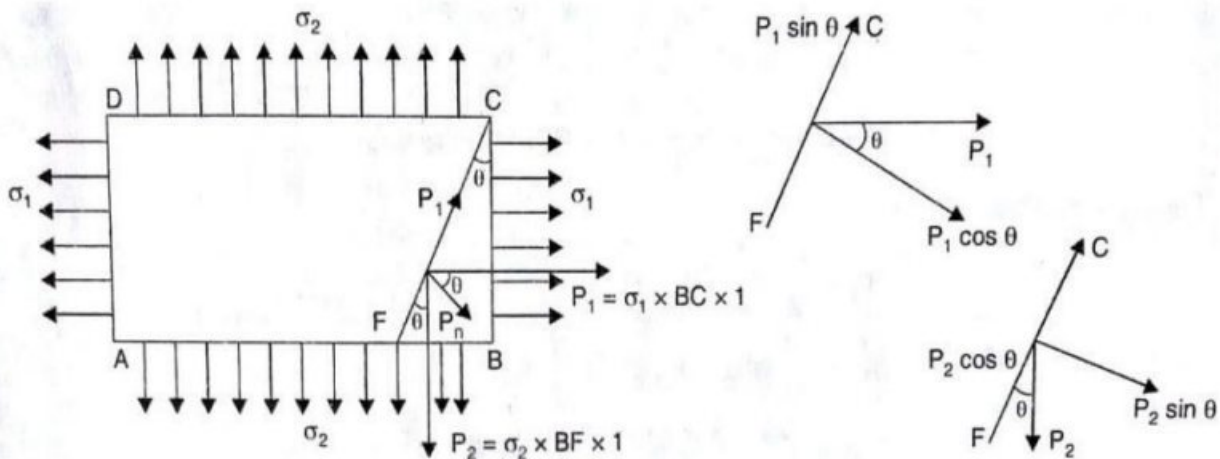

Fig. shows a rectangular bar ABCD of uniform cross sectional area A and of uniform thickness. The bar is subjected to two direct tensile stresses (or two principal tensile stresses) as shown in Fig

Let FC be the oblique section on which stresses are to be calculated. This can be done by converting the stresses σ_1 (acting along on face BC) and σ_2 (acting on face AB) into equivalent forces. Then these forces will be resolved along the incline plane FC and perpendicular to FC. Consider the forces acting on wedge FBC.

Let θ = Angle made by oblique section FC with normal cross section BC

σ_1 = Major tensile stress on face AD and BC

σ_2 = Minor tensile stress on face AB and CD

P_1 = Tensile force on face BC

P_2 = Tensile force on face FB.

The tensile force on face BC,

$$P_1 = \sigma_1 \times \text{Area of face BC} = \sigma_1 \times BC \times 1$$

The tensile force on face FB,

$$P_2 = \sigma_2 \times \text{Area of face FB} = \sigma_2 \times FB \times 1$$

The tensile forces P_1 and P_2 are also acting on the oblique section FC. The force P_1 is acting in the axial direction, whereas the force P_2 is acting downwards as shown in Fig. Two forces P_1 and P_2 each can be resolved into two components i.e., one normal to the plane FC and the other along the plane FC. The components of P_1 and $P_1 \cos \theta$ normal to the plane FC and $P_1 \sin \theta$ along the plane in the upward direction. The components of P_2 and $P_2 \sin \theta$ normal to the plane FC and $P_2 \cos \theta$ along the plane in the downward direction.

Let P_n = Total force normal to section FC

= Component of force P_1 normal to the section FC + Component of force P_2 normal to the section FC

$$= P_1 \cos \theta + P_2 \sin \theta$$

$$= \sigma_1 \times BC \times \cos \theta + \sigma_2 \times FB \times \sin \theta$$

$$(\text{since } P_1 = \sigma_1 \times BC, P_2 = \sigma_2 \times FB)$$

P_t = Total force along the section FC

= Component of force P1 along the section FC + Component of force P2 along the section FC

$$= P_1 \sin\theta - P_2 \cos\theta \quad (\text{-ve sign is taken due to opposite direction})$$

$$= \sigma_1 \times BC \times \sin\theta - \sigma_2 \times BF \times \cos\theta \quad (\because P_1 = \sigma_1 \times BC, P_2 = \sigma_2 \times BF)$$

σ_n = Normal stress across the section FC

$$= \frac{\text{Total force normal to the section FC}}{\text{Area of section FC}}$$

$$= \frac{P_n}{FC \times 1} = \frac{\sigma_1 \times BC \times \cos\theta + \sigma_2 \times BF \times \sin\theta}{FC}$$

$$= \sigma_1 \times \frac{BC}{FC} \times \cos\theta + \sigma_2 \times \frac{BF}{FC} \times \sin\theta$$

$$= \sigma_1 \times \cos\theta \times \cos\theta + \sigma_2 \times \sin\theta \sin\theta$$

$$= \sigma_1 \times \cos^2\theta + \sigma_2 \times \sin^2\theta$$

$$= \sigma_1 \left[\frac{1 + \cos 2\theta}{2} \right] + \sigma_2 \left[\frac{1 - \cos 2\theta}{2} \right]$$

$$= \frac{\sigma_1 + \sigma_2}{2} + \frac{\sigma_1 - \sigma_2}{2} \cos 2\theta$$

σ_t = Tangential stress (or shear stress) along section FC

$$= \frac{\text{Total force along the section FC}}{\text{Area of section FC}}$$

$$= \frac{P_t}{FC \times 1} = \frac{\sigma_1 \times BC \times \sin\theta - \sigma_2 \times BF \times \cos\theta}{FC}$$

$$= \sigma_1 \times \frac{BC}{FC} \times \sin\theta - \sigma_2 \times \frac{BF}{FC} \times \cos\theta$$

$$= \sigma_1 \times \cos\theta \times \sin\theta - \sigma_2 \times \sin\theta \times \cos\theta$$

$$= (\sigma_1 - \sigma_2) \cos\theta \times \sin\theta$$

$$= \frac{(\sigma_1 - \sigma_2)}{2} \times 2 \cos\theta \times \sin\theta$$

$$= \frac{(\sigma_1 - \sigma_2)}{2} \sin 2\theta$$

The resultant stress on the section FC will be given as

$$\sigma_R = \sqrt{\sigma_n^2 + \sigma_t^2}$$

STRENGTH OF MATERIALS

Obliquity. The angle made by the resultant stress with the normal of the oblique plane, is known as obliquity as shown in fig. Mathematically, it is denoted by, $\tan\phi = \frac{\sigma_t}{\sigma_n}$

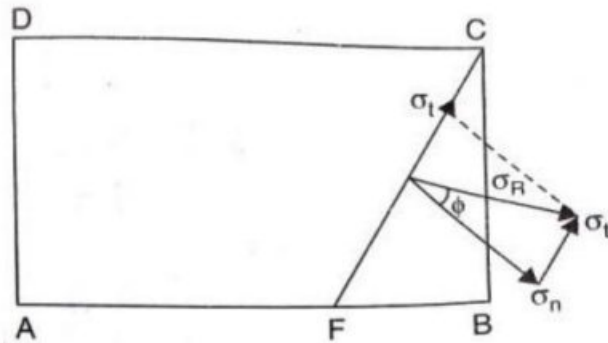

Maximum Shear stress. The shear stress is given by $\sigma_t = \frac{(\sigma_1 - \sigma_2)}{2} \sin 2\theta$. The shear stress will be maximum when

$$\sin 2\theta = 1 \text{ or } 2\theta = 90^\circ \text{ or } 270^\circ$$

$$\therefore \theta = 45^\circ \text{ or } 135^\circ$$

And maximum shear stress $(\sigma_t)_{\max} = \frac{(\sigma_1 - \sigma_2)}{2}$

The planes of maximum shear stress are obtained by making an angle of 45° and 135° with the plane BC (at any point on the plane BC) in such a way that the planes of maximum shear stress lie within the material as shown in Fig.

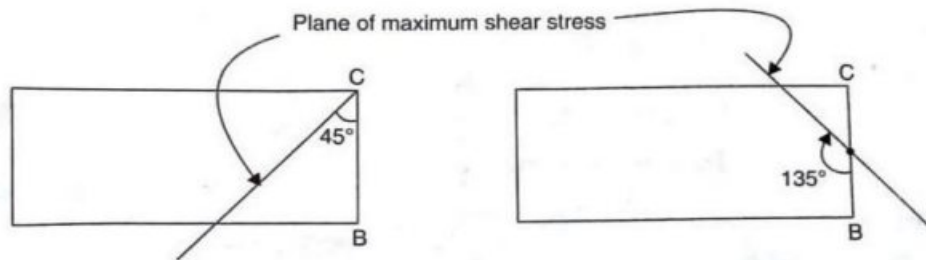

Principal Planes

Principal planes are the planes on which shear stress is zero. To locate the position of principal planes, the shear stress should be equated to zero.

\therefore For principal planes, $\frac{(\sigma_1 - \sigma_2)}{2} \sin 2\theta = 0$

Or $\sin 2\theta = 0$ (since $(\sigma_1 - \sigma_2)$ cannot be = 0)

Or $2\theta = 0 \text{ or } 180^\circ$

Or $\theta = 0$ or 90°

When $\theta = 0$,

$$\begin{aligned}\sigma_n &= \frac{\sigma_1 + \sigma_2}{2} + \frac{\sigma_1 - \sigma_2}{2} \cos 2\theta \\ &= \frac{\sigma_1 + \sigma_2}{2} + \frac{\sigma_1 - \sigma_2}{2} \cos 0 \\ &= \frac{\sigma_1 + \sigma_2}{2} + \frac{\sigma_1 - \sigma_2}{2} \\ &= \sigma_1\end{aligned}$$

When $\theta = 90^\circ$,

$$\begin{aligned}\sigma_n &= \frac{\sigma_1 + \sigma_2}{2} + \frac{\sigma_1 - \sigma_2}{2} \cos(2 \times 90^\circ) \\ &= \frac{\sigma_1 + \sigma_2}{2} + \frac{\sigma_1 - \sigma_2}{2} \cos 180^\circ \\ &= \frac{\sigma_1 + \sigma_2}{2} + \frac{\sigma_1 - \sigma_2}{2} \times -1 \\ &= \sigma_1\end{aligned}$$

1.25.3.A member subjected to simple shear stress.

Fig. shows a rectangular bar ABCD of uniform cross sectional area A and of unit thickness. The bar is subjected to a simple shear stress (τ) across the faces BC and AD. Let FC be the oblique section on which normal and tangential stress are to be calculated.

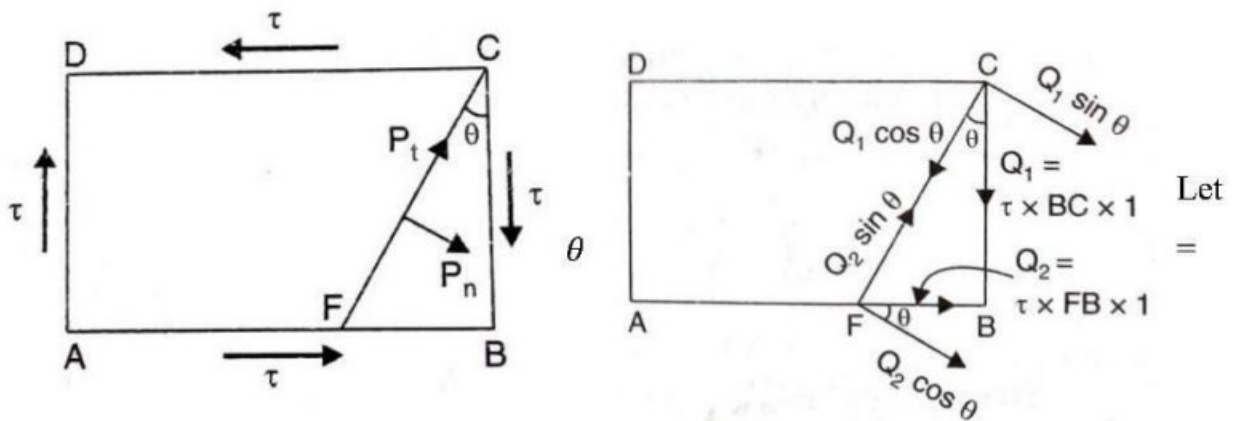

Angle made by oblique section FC with normal cross section BC,

τ = Shear stress across faces BC and AD.

It has already been proved that a shear stress is always accompanied by an equal shear stress at right angles to it. Hence the faces AB and CD will also be subjected to a shear stress τ as shown in above Fig. Now these stress will be converted in to equal forces. Then these forces will be resolved along the inclined surface and normal to the inclined surface. Consider the forces acting on the wedge FBC of fig.

Let $Q_1 =$ shear force on face BC

$$= \text{Shear stress} \times \text{Area of face BC}$$

$$= \tau \times BC \times 1 \quad (\text{Since Area of BC} = BC \times 1)$$

$$= \tau \times BC$$

$Q_2 =$ shear force on face FB

$$= \text{Shear stress} \times \text{Area of face FB}$$

$$= \tau \times FB \times 1 \quad (\text{Since Area of FB} = FB \times 1)$$

$$= \tau \times FB$$

$P_n =$ Total normal force on section FC

$P_t =$ Total tangential force on section FC

The force Q_1 is acting along face CB as shown in Fig. This force is resolved into two components. i.e., $Q_1 \cos\theta$ and $Q_1 \sin\theta$ along the plane CF and normal to the plane CF respectively.

The force Q_2 is acting along face FB as shown in Fig. This force is resolved into two components. i.e., $Q_2 \sin\theta$ and $Q_2 \cos\theta$ along the plane FC and normal to the plane FC respectively.

\therefore Total normal force of section FC,

$$P_n = Q_1 \sin\theta + Q_2 \cos\theta$$

$$= \tau \times BC \sin\theta + \tau \times FB \cos\theta \quad (\text{since } Q_1 = \tau \times BC \text{ and } Q_2 = \tau \times FB)$$

And total tangential force on section FC.

$$P_t = Q_2 \sin\theta - Q_1 \cos\theta \quad (\text{-ve sign is taken due to opposite direction})$$

$$= \tau \times FB \sin\theta - \tau \times BC \cos\theta$$

Let $\sigma_n =$ Normal stress on section FC

$\sigma_t =$ Tangential stress on section FC

$$\begin{aligned}
 \sigma_n &= \frac{\text{Total normal force on section FC}}{\text{Area of section FC}} \\
 &= \frac{P_n}{FC \times 1} \\
 &= \frac{\tau \times BC \sin\theta + \tau \times FB \cos\theta}{FC \times 1} \\
 &= \tau \frac{BC}{FC} \sin\theta + \tau \frac{FB}{FC} \cos\theta \\
 &= \tau \cos\theta \sin\theta + \tau \sin\theta \cos\theta \\
 &= 2 \tau \cos\theta \sin\theta \\
 &= \tau \sin 2\theta \\
 \sigma_t &= \frac{\text{Total tangential force on section FC}}{\text{Area of section FC}} \\
 &= \frac{P_t}{FC \times 1} \\
 &= \frac{\tau \times FB \sin\theta - \tau \times BC \cos\theta}{FC \times 1} \\
 &= \tau \frac{FB}{FC} \sin\theta - \tau \frac{BC}{FC} \cos\theta \\
 &= \tau \sin\theta \sin\theta - \tau \cos\theta \cos\theta \\
 &= \tau \sin^2\theta - \tau \cos^2\theta \\
 &= -\tau (\cos^2\theta - \sin^2\theta) \\
 &= -\tau \cos 2\theta
 \end{aligned}$$

-ve sign shows that σ_t will be acting downwards on the plane CF.

1.25.4. A member subjected to Direct stresses in two mutually perpendicular Directions Accompanied by a simple shear stress.

Above fig. shows a rectangular bar ABCD of uniform cross sectional area A and of unit thickness. The bar is subjected to :

- (i) tensile stress σ_1 on the face BC and AD
- (ii) tensile stress σ_2 on the face AB and CD
- (iii) a simple shear stress τ on face BC and AD.

The forces acting on the wedge FBC are:

$$P_1 = \text{Tensile force on face BC due to tensile stress } \sigma_1$$

STRENGTH OF MATERIALS

$$= \sigma_1 \times \text{Area of BC}$$

$$= \sigma_1 \times BC \times 1$$

$$= \sigma_1 \times BC$$

P_2 = Tensile force on face BC due to tensile stress σ_2

$$= \sigma_2 \times \text{Area of FB}$$

$$= \sigma_2 \times FB \times 1$$

$$= \sigma_2 \times FB$$

Q_1 = Shear force on the face BC due to shear stress τ

$$= \tau \times \text{Area of BC}$$

$$= \tau \times BC \times 1$$

$$= \tau \times BC$$

Q_2 = Shear force on the face FB due to shear stress τ

$$= \tau \times \text{Area of FB}$$

$$= \tau \times FB \times 1$$

$$= \tau \times FB$$

Resolving the above four forces (i.e., P_1, P_2, Q_1 and Q_2) normal to the oblique section FC, we get

Total normal force,

$$P_n = P_1 \cos\theta + P_2 \sin\theta + Q_1 \sin\theta + Q_2 \cos\theta$$

Substituting the values of P_1, P_2, Q_1 , and Q_2 , we get

$$P_n = \sigma_1 \cdot BC \cdot \cos\theta + \sigma_2 \cdot FB \cdot \sin\theta + \tau \cdot BC \cdot \sin\theta + \tau \cdot FB \cdot \cos\theta$$

Similarly, the total tangential force (P_t) is obtained by resolving P_1, P_2, Q_1 and Q_2 along the oblique section FC

∴ Total tangential force,

$$P_t = P_1 \sin\theta - P_2 \cos\theta - Q_1 \cos\theta + Q_2 \sin\theta$$

$$= \sigma_1 \cdot BC \cdot \sin\theta - \sigma_2 \cdot FB \cdot \cos\theta - \tau \cdot BC \cdot \cos\theta + \tau \cdot FB \cdot \sin\theta$$

Now, Let σ_n = Normal stress across the section FC, and

$$\sigma_t = \text{Tangential stress across the section FC,}$$

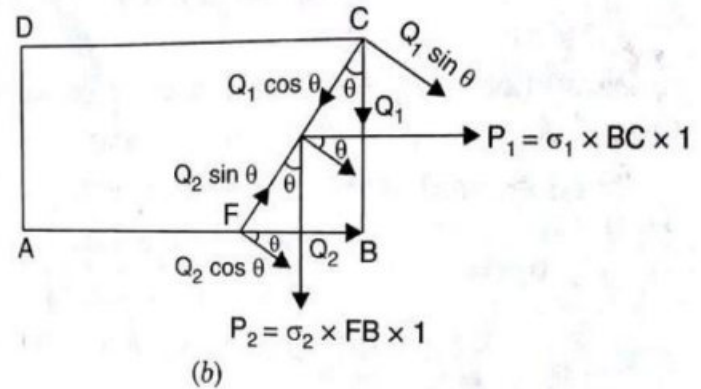
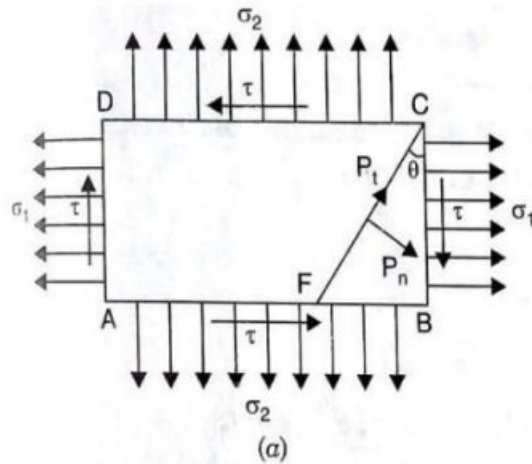

$$\sigma_n = \frac{\text{Total normal force across section FC}}{\text{Area of section FC}}$$

$$= \frac{P_n}{FC \times 1}$$

$$= \frac{\sigma_1 BC \cdot \cos\theta + \sigma_2 FB \cdot \sin\theta + \tau BC \cdot \sin\theta + \tau FB \cdot \cos\theta}{FC \times 1}$$

$$= \sigma_1 \frac{BC}{FC} \cdot \cos\theta + \sigma_2 \frac{FB}{FC} \cdot \sin\theta + \tau \frac{BC}{FC} \cdot \sin\theta + \tau \frac{FB}{FC} \cdot \cos\theta$$

$$= \sigma_1 \cos\theta \cdot \cos\theta + \sigma_2 \sin\theta \cdot \sin\theta + \tau \cos\theta \cdot \sin\theta + \tau \sin\theta \cdot \cos\theta$$

$$= \sigma_1 \cos^2\theta + \sigma_2 \sin^2\theta + 2\tau \cos\theta \cdot \sin\theta$$

$$= \sigma_1 \left[\frac{1 + \cos 2\theta}{2} \right] + \sigma_2 \left[\frac{1 - \cos 2\theta}{2} \right] + \tau \sin 2\theta$$

$$= \frac{\sigma_1 + \sigma_2}{2} + \frac{\sigma_1 - \sigma_2}{2} \cos 2\theta + \tau \sin 2\theta \quad \dots(i)$$

Tangential stress (i.e., shear stress) across the section FC,

$$\sigma_t = \frac{\text{Total tangential force across section FC}}{\text{Area of section FC}}$$

$$= \frac{P_t}{FC \times 1}$$

$$= \frac{\sigma_1 BC \cdot \sin\theta - \sigma_2 FB \cdot \cos\theta - \tau BC \cdot \cos\theta + \tau FB \cdot \sin\theta}{FC \times 1}$$

$$= \sigma_1 \frac{BC}{FC} \cdot \sin\theta - \sigma_2 \frac{FB}{FC} \cdot \cos\theta - \tau \frac{BC}{FC} \cdot \cos\theta + \tau \frac{FB}{FC} \cdot \sin\theta$$

$$= \sigma_1 \cos\theta \cdot \sin\theta - \sigma_2 \sin\theta \cdot \cos\theta - \tau \cos\theta \cdot \cos\theta + \tau \sin\theta \cdot \sin\theta$$

$$\begin{aligned}
 &= (\sigma_1 - \sigma_2) \cdot \cos\theta \sin\theta - \tau \cos^2\theta + \tau \sin^2\theta \\
 &= \frac{\sigma_1 - \sigma_2}{2} 2 \cos\theta \sin\theta - \tau (\cos^2\theta - \sin^2\theta) \\
 &= \frac{\sigma_1 - \sigma_2}{2} \sin 2\theta - \tau \cos 2\theta \quad \dots(ii)
 \end{aligned}$$

Position of principal planes.

The planes on which shear stress (i.e., tangential stress) is zero are known as principal planes. And the stress acting on principal planes are known as principal stresses.

The position of principal planes are obtained by equating the tangential stress to zero

∴ For principal planes, $\sigma_t = 0$

Or $\frac{\sigma_1 - \sigma_2}{2} \sin 2\theta - \tau \cos 2\theta = 0$

Or $\frac{\sigma_1 - \sigma_2}{2} \sin 2\theta = \tau \cos 2\theta$

Or $\frac{\sin 2\theta}{\cos 2\theta} = \frac{\tau}{\frac{\sigma_1 - \sigma_2}{2}} = \frac{2\tau}{\sigma_1 - \sigma_2}$

Or $\tan 2\theta = \frac{2\tau}{\sigma_1 - \sigma_2}$

But the tangent of any angle in a right angled triangle

$$= \frac{\text{Height of right angled triangle}}{\text{Base of right angled triangle}} = \frac{2\tau}{\sigma_1 - \sigma_2}$$

Now diagonal of the right angled triangle

$$\begin{aligned}
 &= \sqrt{(\sigma_1 - \sigma_2)^2 + (2\tau)^2} \\
 &= \pm \sqrt{(\sigma_1 - \sigma_2)^2 + 4\tau^2}
 \end{aligned}$$

1st case

Diagonal = $\sqrt{(\sigma_1 - \sigma_2)^2 + 4\tau^2}$

Then $\sin 2\theta = \frac{\text{Height}}{\text{Diagonal}} = \frac{2\tau}{\sqrt{(\sigma_1 - \sigma_2)^2 + 4\tau^2}}$

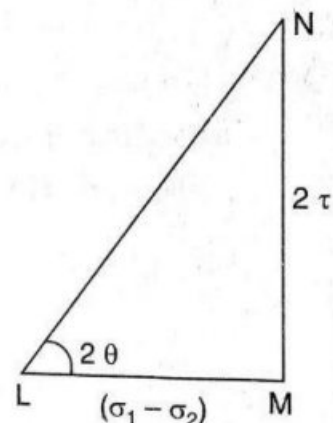

$$\text{And } \cos 2\theta = \frac{\text{Base}}{\text{Diagonal}} = \frac{(\sigma_1 - \sigma_2)}{\sqrt{(\sigma_1 - \sigma_2)^2 + 4\tau^2}}$$

The value of major principal stress is obtained by substituting the values of $\sin 2\theta$ and $\cos 2\theta$ in equation (i)

∴ Major Principal stress

$$\begin{aligned} &= \frac{\sigma_1 + \sigma_2}{2} + \frac{\sigma_1 - \sigma_2}{2} \cos 2\theta + \tau \sin 2\theta \\ &= \frac{\sigma_1 + \sigma_2}{2} + \frac{\sigma_1 - \sigma_2}{2} \frac{(\sigma_1 - \sigma_2)}{\sqrt{(\sigma_1 - \sigma_2)^2 + 4\tau^2}} + \tau \frac{2\tau}{\sqrt{(\sigma_1 - \sigma_2)^2 + 4\tau^2}} \\ &= \frac{\sigma_1 + \sigma_2}{2} + \frac{1}{2} \frac{(\sigma_1 - \sigma_2)^2}{\sqrt{(\sigma_1 - \sigma_2)^2 + 4\tau^2}} + \frac{2\tau^2}{\sqrt{(\sigma_1 - \sigma_2)^2 + 4\tau^2}} \\ &= \frac{\sigma_1 + \sigma_2}{2} + \frac{(\sigma_1 - \sigma_2)^2 + 4\tau^2}{2\sqrt{(\sigma_1 - \sigma_2)^2 + 4\tau^2}} \\ &= \frac{\sigma_1 + \sigma_2}{2} + \frac{1}{2} \sqrt{(\sigma_1 - \sigma_2)^2 + 4\tau^2} \\ &= \frac{\sigma_1 + \sigma_2}{2} + \sqrt{\left(\frac{\sigma_1 - \sigma_2}{2}\right)^2 + \tau^2} \quad \dots \text{(iii)} \end{aligned}$$

2nd case

$$\text{Diagonal} = -\sqrt{(\sigma_1 - \sigma_2)^2 + 4\tau^2}$$

$$\text{Then } \sin 2\theta = \frac{\text{Height}}{\text{Diagonal}} = \frac{2\tau}{-\sqrt{(\sigma_1 - \sigma_2)^2 + 4\tau^2}}$$

$$\text{And } \cos 2\theta = \frac{\text{Base}}{\text{Diagonal}} = \frac{(\sigma_1 - \sigma_2)}{-\sqrt{(\sigma_1 - \sigma_2)^2 + 4\tau^2}}$$

Substituting these values in equation (i), we get minor principal stress

∴ Minor principal stress

$$\begin{aligned} &= \frac{\sigma_1 + \sigma_2}{2} + \frac{\sigma_1 - \sigma_2}{2} \cos 2\theta + \tau \sin 2\theta \\ &= \frac{\sigma_1 + \sigma_2}{2} + \frac{\sigma_1 - \sigma_2}{2} \frac{(\sigma_1 - \sigma_2)}{-\sqrt{(\sigma_1 - \sigma_2)^2 + 4\tau^2}} + \tau \frac{2\tau}{-\sqrt{(\sigma_1 - \sigma_2)^2 + 4\tau^2}} \\ &= \frac{\sigma_1 + \sigma_2}{2} - \frac{1}{2} \frac{(\sigma_1 - \sigma_2)^2}{\sqrt{(\sigma_1 - \sigma_2)^2 + 4\tau^2}} - \frac{2\tau^2}{\sqrt{(\sigma_1 - \sigma_2)^2 + 4\tau^2}} \end{aligned}$$

$$\begin{aligned}
 &= \frac{\sigma_1 + \sigma_2}{2} - \frac{(\sigma_1 - \sigma_2)^2 + 4\tau^2}{2\sqrt{(\sigma_1 - \sigma_2)^2 + 4\tau^2}} \\
 &= \frac{\sigma_1 + \sigma_2}{2} - \frac{1}{2}\sqrt{(\sigma_1 - \sigma_2)^2 + 4\tau^2} \\
 &= \frac{\sigma_1 + \sigma_2}{2} - \sqrt{\left(\frac{\sigma_1 - \sigma_2}{2}\right)^2 + \tau^2} \quad \dots(iv)
 \end{aligned}$$

Equation (iii) gives the maximum principal stress whereas equation (iv) gives the minimum principal stress. The two principal planes are at right angles.

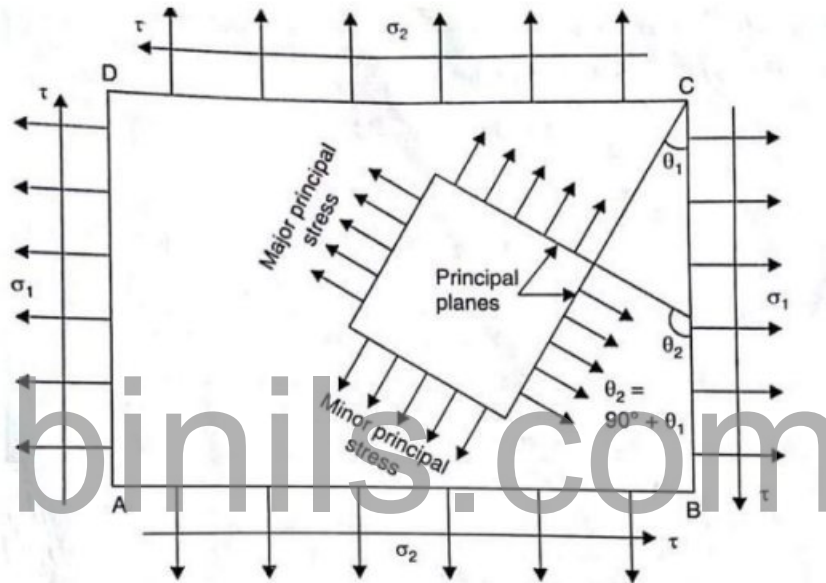

Maximum shear stress.

The shear stress will be maximum or minimum when $\frac{d}{dt}(\sigma_t) = 0$

$$\frac{d}{dt} \left[\frac{\sigma_1 - \sigma_2}{2} \sin 2\theta - \tau \cos 2\theta \right] = 0$$

$$\frac{\sigma_1 - \sigma_2}{2} (\cos 2\theta) \times 2 - \tau (-\sin 2\theta) \times 2 = 0$$

$$(\sigma_1 - \sigma_2) \cdot \cos 2\theta + 2\tau (\sin 2\theta) = 0$$

$$2\tau (\sin 2\theta) = -(\sigma_1 - \sigma_2) \cdot \cos 2\theta$$

$$= (\sigma_2 - \sigma_1) \cdot \cos 2\theta$$

Or

$$\frac{\sin 2\theta}{\cos 2\theta} = \frac{\sigma_2 - \sigma_1}{2\tau}$$

Or
$$\tan 2\theta = \frac{\sigma_2 - \sigma_1}{2\tau} \quad \dots(v)$$

Equation (v) gives condition for maximum or minimum shear stress.

If
$$\tan 2\theta = \frac{\sigma_2 - \sigma_1}{2\tau}$$

Then,
$$\sin 2\theta = \frac{\text{Height}}{\text{Diagonal}} = \pm \frac{\sigma_2 - \sigma_1}{\sqrt{(\sigma_2 - \sigma_1)^2 + 4\tau^2}}$$

And
$$\cos 2\theta = \frac{\text{Base}}{\text{Diagonal}} = \pm \frac{2\tau}{\sqrt{(\sigma_2 - \sigma_1)^2 + 4\tau^2}}$$

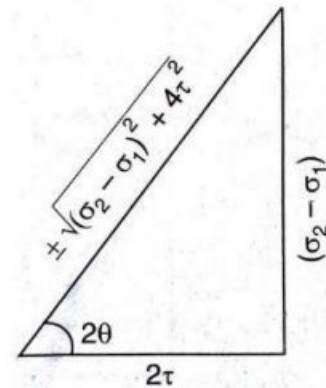

Substituting the values of $\sin 2\theta$ and $\cos 2\theta$ in equation (ii), the maximum and minimum shear stresses are obtained.

$$\begin{aligned} (\sigma_t)_{\max} &= \frac{\sigma_1 - \sigma_2}{2} \sin 2\theta - \tau \cos 2\theta \\ &= \pm \frac{\sigma_1 - \sigma_2}{2} \times \frac{\sigma_2 - \sigma_1}{\sqrt{(\sigma_2 - \sigma_1)^2 + 4\tau^2}} \pm \tau \frac{2\tau}{\sqrt{(\sigma_2 - \sigma_1)^2 + 4\tau^2}} \\ &= \pm \frac{(\sigma_2 - \sigma_1)^2}{2\sqrt{(\sigma_2 - \sigma_1)^2 + 4\tau^2}} \pm \frac{2\tau^2}{\sqrt{(\sigma_2 - \sigma_1)^2 + 4\tau^2}} \\ &= \pm \frac{(\sigma_2 - \sigma_1)^2 + 4\tau^2}{2\sqrt{(\sigma_2 - \sigma_1)^2 + 4\tau^2}} \\ &= \pm \frac{1}{2} \sqrt{(\sigma_2 - \sigma_1)^2 + (2\tau)^2} \\ (\sigma_t)_{\max} &= \frac{1}{2} \sqrt{(\sigma_2 - \sigma_1)^2 + 4\tau^2} \\ &= \frac{1}{2} \sqrt{(\sigma_1 - \sigma_2)^2 + 4\tau^2} \quad \dots(vi) \end{aligned}$$

The planes on which maximum shear stress is acting, are obtained after finding the two values of θ from equation (v). These two values of θ will differ by 90° .

The second method of finding the planes of maximum shear stress is to find first principal planes and principal stresses. Let θ_1 is the angle of principal plane with plane BC of Fig. Then the planes of maximum shear stress will be at $\theta_1 + 45^\circ$ and $\theta_1 + 135^\circ$ with plane BC as shown in below Fig.

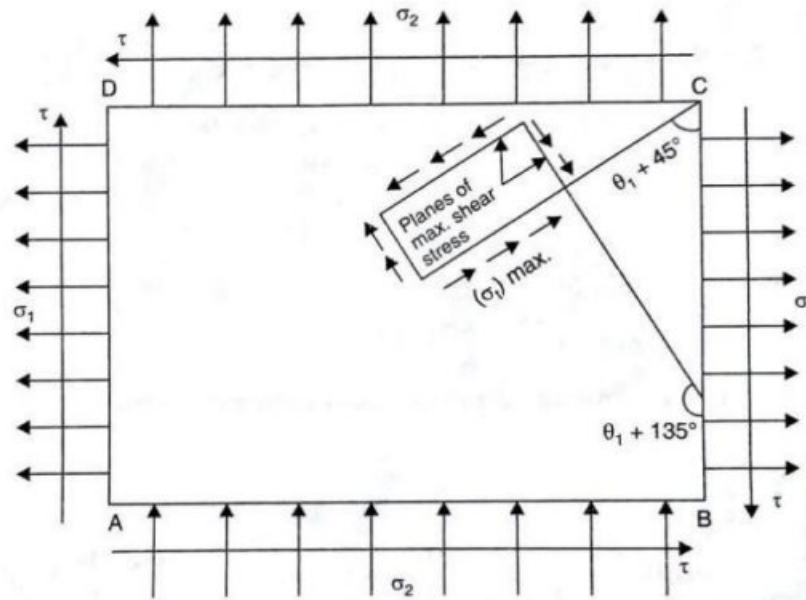

Problem.1.21. The tensile stresses at a point across two mutually perpendicular planes are 120N/mm^2 and 60N/mm^2 . Determine the normal, tangential and resultant stresses on a plane inclined at 30° to the axis of minor stress

Given Data

Major principal stress, $\sigma_1 = 120\text{N/mm}^2$

Minor principal stress, $\sigma_2 = 60\text{N/mm}^2$

Angle of oblique plane with the axis of minor principal stress,

$$\theta = 30^\circ$$

To find

The normal, tangential and resultant stresses.

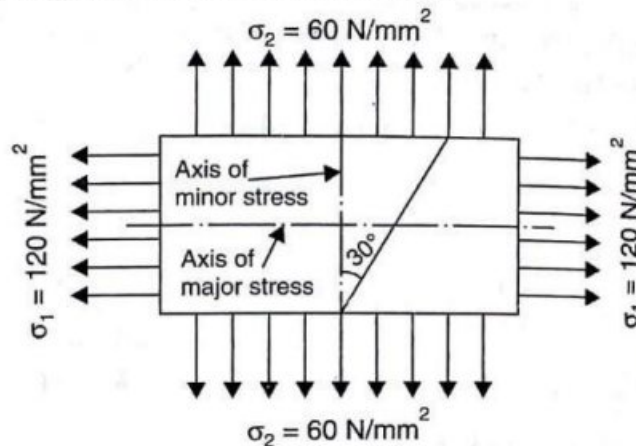

Normal stress(σ_n)

$$\begin{aligned}\sigma_n &= \frac{\sigma_1 + \sigma_2}{2} + \frac{\sigma_1 - \sigma_2}{2} \cos 2\theta \\ &= \frac{120 + 60}{2} + \frac{120 - 60}{2} \cos 2 \times 30^\circ \\ &= 105 \text{N/mm}^2\end{aligned}$$

Tangential stress(σ_t)

$$\begin{aligned}\sigma_t &= \frac{(\sigma_1 - \sigma_2)}{2} \sin 2\theta \\ &= \frac{120 - 60}{2} \sin 2 \times 30 = 25.98 \text{N/mm}^2\end{aligned}$$

Resultant stress(σ_R)

The resultant stress on the section FC will be given as

$$\begin{aligned}\sigma_R &= \sqrt{\sigma_n^2 + \sigma_t^2} \\ &= \sqrt{105^2 + 25.98^2} = 108.16 \text{N/mm}^2\end{aligned}$$

Problem.1.22. The stresses at a point in a bar are 200N/mm^2 (tensile) and 100N/mm^2 (compressive). Determine the resultant stress in magnitude and direction on a plane inclined at 60° to the axis of major stress. Also determine the maximum intensity of shear stress in the material at the point.

Given Data

Major principal stress, $\sigma_1 = 200 \text{N/mm}^2$

Minor principal stress, $\sigma_2 = -100 \text{N/mm}^2$ (-ve sign is due to compressive stress)

Angle of oblique plane with the axis of minor principal stress,

$$\theta = 90^\circ - 60^\circ = 30^\circ$$

To find

The Magnitude and direction Resultant stress and maximum intensity of shear stress

Solution

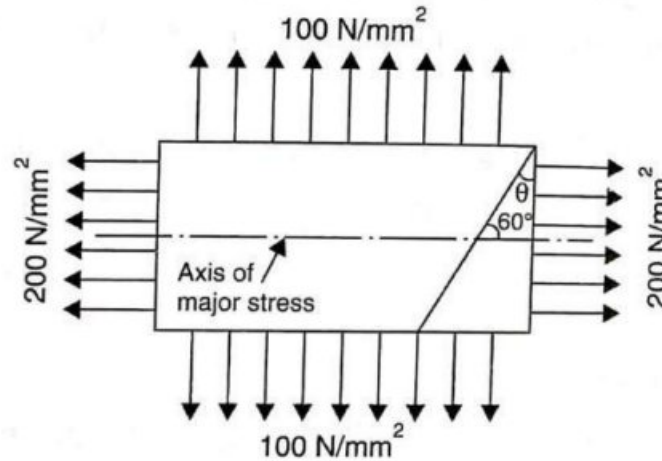

Normal stress(σ_n)

$$\begin{aligned}\sigma_n &= \frac{\sigma_1 + \sigma_2}{2} + \frac{\sigma_1 - \sigma_2}{2} \cos 2\theta \\ &= \frac{200 - 100}{2} + \frac{200 + 100}{2} \cos 2 \times 30^\circ = 125 \text{ N/mm}^2\end{aligned}$$

Tangential stress(σ_t)

$$\begin{aligned}\sigma_t &= \frac{(\sigma_1 - \sigma_2)}{2} \sin 2\theta \\ &= \frac{200 + 100}{2} \sin 2 \times 30 = 129.9 \text{ N/mm}^2\end{aligned}$$

Resultant stress(σ_R)

The resultant stress on the section FC will be given as

$$\begin{aligned}\sigma_R &= \sqrt{\sigma_n^2 + \sigma_t^2} \\ &= \sqrt{125^2 + 129.9^2} = 180.27 \text{ N/mm}^2\end{aligned}$$

Direction of Resultant stress

$$\begin{aligned}\tan \phi &= \frac{\sigma_t}{\sigma_n} = \frac{129.9}{125} = 1.04 \\ \phi &= \tan^{-1} 1.04 = 46^\circ 6'\end{aligned}$$

Maximum Shear stress

$$\begin{aligned}(\sigma_t)_{\max} &= \frac{(200 + 100)}{2} \\ &= 150 \text{ N/mm}^2\end{aligned}$$

Problem.1.23. At a point within a body subjected to two mutually perpendicular directions, the stresses are 80 N/mm^2 tensile and 40 N/mm^2 tensile. Each of the above stresses is accompanied by a shear stress of 60 N/mm^2 . Determine the normal stress, shear stress and resultant stress on an oblique plane inclined at an angle of 45° with the axis of minor tensile stress.

Given Data

Major principal stress, $\sigma_1 = 80 \text{ N/mm}^2$

Minor principal stress, $\sigma_2 = 40 \text{ N/mm}^2$

Shear stress $\tau = 60 \text{ N/mm}^2$

Angle of oblique plane with the axis

of minor principal stress, $\theta = 45^\circ$

To find

The normal, tangential and resultant stresses.

Solution.

Normal stress(σ_n)

$$\begin{aligned} &= \frac{\sigma_1 + \sigma_2}{2} + \frac{\sigma_1 - \sigma_2}{2} \cos 2\theta + \tau \sin 2\theta \\ &= \frac{80 + 40}{2} + \frac{80 - 40}{2} \cos(2 \times 45) + 60 \times \sin 2 \times 45 \\ &= 120 \text{ N/mm}^2 \end{aligned}$$

Tangential stress(σ_t)

$$\begin{aligned} \sigma_t &= \frac{\sigma_1 - \sigma_2}{2} \sin 2\theta - \tau \cos 2\theta \\ &= \frac{80 - 40}{2} \sin(2 \times 45) - 60 \times \cos(2 \times 45) \\ &= 20 \text{ N/mm}^2. \end{aligned}$$

Resultant stress(σ_R)

The resultant stress on the section FC will be given as

$$\begin{aligned} \sigma_R &= \sqrt{\sigma_n^2 + \sigma_t^2} \\ &= \sqrt{120^2 + 20^2} = 121.655 \text{ N/mm}^2 \end{aligned}$$

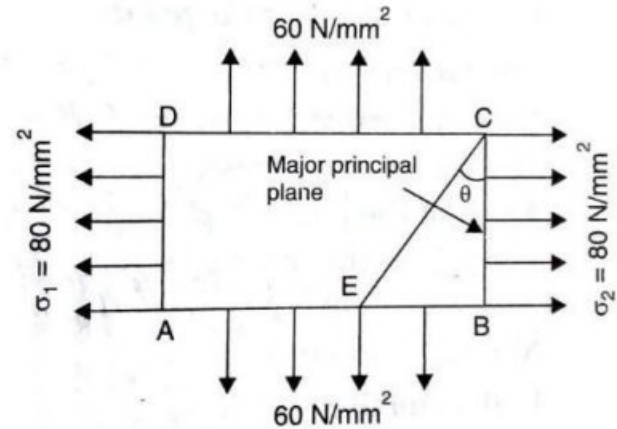

STRENGTH OF MATERIALS

Problem 1.24. A rectangular block of material is subjected to a tensile stress of 110N/mm^2 on one plane and a tensile stress of 47N/mm^2 on the plane right angles on the former. Each of the above stresses is accompanied by a shear stress of 63N/mm^2 and that associated with the former tensile stress tends to rotate the block anticlockwise. Find (i) the direction and magnitude of each of the principal stress and (ii) magnitude of the greatest shear stress.

Given Data

Major principal stress, $\sigma_1 = 110\text{N/mm}^2$

Minor principal stress, $\sigma_2 = 47\text{N/mm}^2$

Shear stress $\tau = 63\text{N/mm}^2$

To find

- (i) The direction and magnitude of each of the principal stress and
- (ii) The magnitude of the greatest shear stress.

Solution

(i) Direction and Magnitude of principal stresses.

Major Principal stress

$$\begin{aligned} &= \frac{\sigma_1 + \sigma_2}{2} + \sqrt{\left(\frac{\sigma_1 - \sigma_2}{2}\right)^2 + \tau^2} \\ &= \frac{110 + 47}{2} + \sqrt{\left(\frac{110 - 47}{2}\right)^2 + 63^2} \\ &= 148.936\text{N/mm}^2. \end{aligned}$$

Minor Principal stress

$$\begin{aligned} &= \frac{\sigma_1 + \sigma_2}{2} - \sqrt{\left(\frac{\sigma_1 - \sigma_2}{2}\right)^2 + \tau^2} \\ &= \frac{110 + 47}{2} - \sqrt{\left(\frac{110 - 47}{2}\right)^2 + 63^2} = 8.064\text{N/mm}^2 \end{aligned}$$

Direction of Resultant stress

$$\begin{aligned} \tan 2\theta &= \frac{2\tau}{\sigma_1 - \sigma_2} = \frac{2 \times 63}{110 - 47} = 2 \\ 2\theta &= \tan^{-1} 2 = 63^\circ 26' \text{ or } 243^\circ 26' \end{aligned}$$

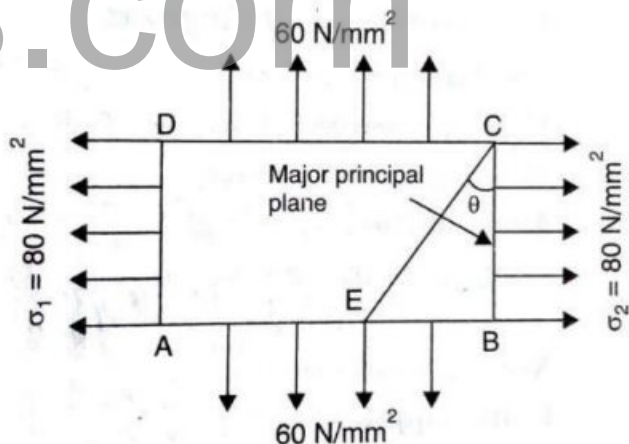

Or $\theta = 31^\circ 43'$ or $121^\circ 26'$

(ii) Magnitude of greatest shear stress

$$\begin{aligned}(\sigma_t)_{\max} &= \frac{1}{2} \sqrt{(\sigma_1 - \sigma_2)^2 + 4\tau^2} \\ &= \frac{1}{2} \sqrt{(110 - 47)^2 + 4 \times 63^2} = 70.436 \text{ N/mm}^2\end{aligned}$$

1.26. MOHR'S CIRCLE

Mohr's circle is a graphical method of finding normal, tangential and resultant stresses on an oblique plane. Mohr's circle will be drawn for the following cases:

- (i) A body subjected to two mutually perpendicular principal tensile stresses of unequal intensities
- (ii) A body subjected to two mutually perpendicular principal stresses which are unequal and unlike (i.e., one is tensile and other is compressive).
- (iii) A body subjected to two mutually perpendicular principal tensile stresses accompanied by a simple shear stress.

1.26.1 Mohr's Circle When A Body Is Subjected To Two Mutually Perpendicular Principal Tensile Stresses Of Unequal Intensities.

Consider a rectangular body subjected to two mutually perpendicular principal tensile stresses of unequal intensities. It is required to find the resultant stress on an oblique plane.

Let σ_1 = Major tensile stress

σ_2 = Minor tensile stress and

θ = Angle made by the oblique plane with the axis of minor tensile stress.

Mohr's Circle is drawn as follows:

Take any point A and draw a horizontal line through A. Take $AB = \sigma_1$ and $AC = \sigma_2$ towards right from A to some suitable scale. With BC as diameter describe a circle. Let O is the centre of the circle. Now through O, draw a line OE making an angle 2θ with OB.

From E, draw ED perpendicular on AB. Join AE. Then the normal and tangential stresses on the oblique plane are given by AD and ED respectively. The resultant stress on the oblique plane is given by AE

STRENGTH OF MATERIALS

From Fig.

Length AD = Normal stress on oblique plane

Length ED = Tangential stress on oblique plane.

Length AE = Resultant stress on oblique plane.

$$\text{Radius of Mohr's circle} = \frac{\sigma_1 - \sigma_2}{2}$$

Angle θ = obliquity.

Problem 1.25. The tensile stresses at a point across two mutually perpendicular planes are 120N/mm^2 and 60N/mm^2 . Determine the normal, tangential and resultant stresses on a plane inclined at 30° to the axis of minor stress by Mohr's circle method

Given Data

Major principal stress, $\sigma_1 = 120\text{N/mm}^2$ (tensile)

Minor principal stress, $\sigma_2 = 60\text{N/mm}^2$ (tensile)

Angle of oblique plane with the axis of minor principal stress,

$$\theta = 30^\circ$$

To find

The normal, tangential and resultant stresses

Solution

Scale. Let $1\text{cm} = 10\text{N/mm}^2$

Then $\sigma_1 = \frac{120}{10} = 12\text{cm}$ and

$$\sigma_2 = \frac{60}{10} = 6\text{cm}$$

Mohr's circle is drawn as:

Take any point A and draw a horizontal line through A. Take $AB = \sigma_1 = 12\text{cm}$ and AC

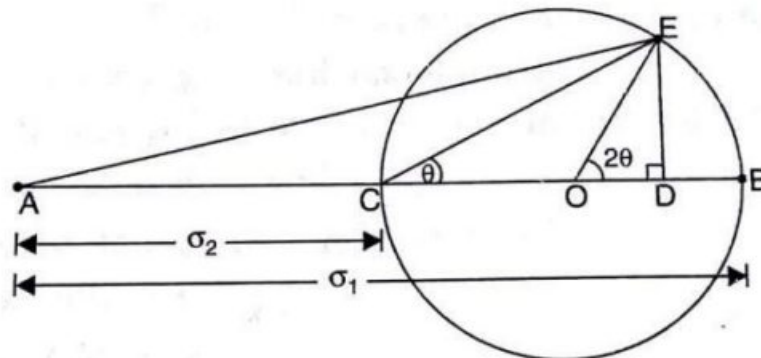

= $\sigma_2=6\text{cm}$. With BC as diameter (i.e., $BC=12-6=6\text{cm}$) describe a circle. Let O is the centre of the circle. Through O, draw a line OE making an angle 2θ (i.e., $2 \times 30 = 60^\circ$) with OB. From E, draw ED perpendicular to CB. Join AE. Measure the length AD, ED and AE.

By measurements :

$$\text{Length AD} = 10.50\text{cm}$$

$$\text{Length ED} = 2.60\text{cm}$$

$$\text{Length AE} = 10.82\text{cm}$$

$$\begin{aligned} \text{Then normal stress} &= \text{Length AD} \times \text{Scale} \\ &= 10.50 \times 10 = \mathbf{105\text{N/mm}^2} \end{aligned}$$

$$\begin{aligned} \text{Tangential or shear stress} &= \text{Length ED} \times \text{Scale} \\ &= 2.60 \times 10 = \mathbf{26\text{ N/mm}^2}. \end{aligned}$$

$$\begin{aligned} \text{Resultant stress} &= \text{Length AE} \times \text{Scale.} \\ &= 10.82 \times 10 = \mathbf{108.2\text{N/mm}^2}. \end{aligned}$$

1.26.2. Mohr's Circle when a Body is subjected to two Mutually perpendicular Principal stresses which are Unequal and Unlike (i.e., one is Tensile and other is Compressive).

Consider a rectangular body subjected to two mutually perpendicular principal stresses which are unequal and one of them is tensile and the other is compressive. It is required to find the resultant stress on an oblique plane.

Let σ_1 = Major principal tensile stress

σ_2 = Minor principal compressive stress and

θ = Angle made by the oblique plane with the axis of minor tensile stress.

Mohr's Circle is drawn as follows:

Take any point A and draw a horizontal line through A on both sides of A as shown in fig. Take $AB = \sigma_1 (+)$ towards right of A and $AC = \sigma_2 (-)$ towards left of A to some suitable scale. Bisect BC at O. With O as centre and radius equal to CO or OB, draw a circle. Through O draw a line OE making an angle 2θ with OB.

From E, draw ED perpendicular to AB. Join AE and CE. Then the normal and tangential stresses on the oblique plane are given by AD and ED respectively. The resultant stress on the oblique plane is given by AE

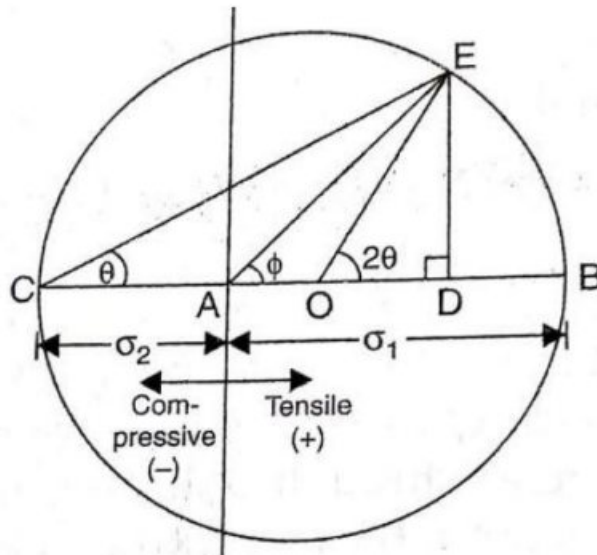

From Fig.

Length AD = Normal stress on oblique plane

Length ED = Tangential stress on oblique plane.

Length AE = Resultant stress on oblique plane.

$$\text{Radius of Mohr's circle} = \frac{\sigma_1 + \sigma_2}{2}$$

Angle ϕ = obliquity.

Problem 1.26. The stresses at a point in a bar are 200N/mm^2 (tensile) and 100N/mm^2 (compressive). Determine the resultant stress in magnitude and direction on a plane inclined at 60° to the axis of major stress. Also determine the maximum intensity of shear stress in the material at the point.

Given Data

Major principal stress, $\sigma_1 = 200\text{N/mm}^2$

Minor principal stress, $\sigma_2 = -100\text{N/mm}^2$

(-ve sign is due to compressive stress)

Angle of oblique plane with the axis of minor principal stress,

$$\theta = 90^\circ - 60^\circ = 30^\circ$$

To find

The Magnitude and direction Resultant stress and maximum intensity of shear stress

Solution

Scale. Let $1\text{cm} = 20\text{N/mm}^2$

Then $\sigma_1 = \frac{200}{20} = 10\text{cm}$ and

$$\sigma_2 = -\frac{100}{20} = -5\text{cm}$$

Mohr's circle is drawn as:

Take any point A and draw a horizontal line through A on both sides of A as shown in fig. Take $AB = \sigma_1 = 10\text{cm}$ towards right of A and $AC = \sigma_2 = -5\text{cm}$ towards left of A to some suitable scale. Bisect BC at O. With O as centre and radius equal to CO or OB, draw a circle. Through O draw a line OE making an angle 2θ (i.e., $2 \times 30 = 60^\circ$) with OB.

From E, draw ED perpendicular to AB. Join AE and CE. Then the normal and tangential stresses on the oblique plane are given by AD and ED respectively. The resultant stress on the oblique plane is given by AE

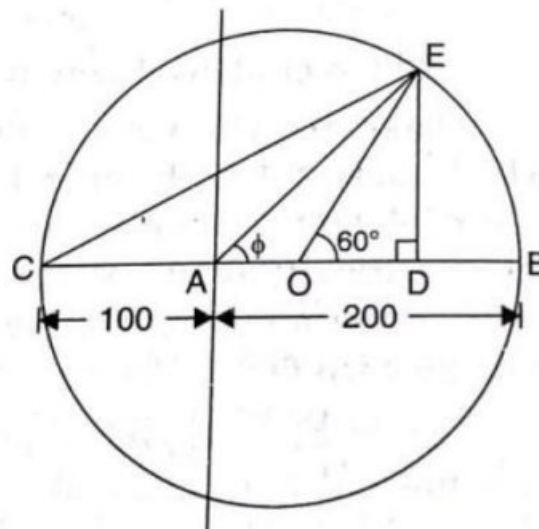

By measurements:

Length AD = 6.25cm

Length ED = 6.5cm and

$$\text{Length AE} = 9.0\text{cm}$$

$$\begin{aligned}\text{Then normal stress} &= \text{Length AD} \times \text{Scale} \\ &= 6.25 \times 20 = \mathbf{125\text{N/mm}^2}\end{aligned}$$

$$\begin{aligned}\text{Tangential or shear stress} &= \text{Length ED} \times \text{Scale} \\ &= 6.5 \times 20 = \mathbf{130\text{ N/mm}^2}.\end{aligned}$$

$$\begin{aligned}\text{Resultant stress} &= \text{Length AE} \times \text{Scale.} \\ &= 9 \times 20 = \mathbf{180\text{N/mm}^2}\end{aligned}$$

1.26.3. Mohr's Circle when a Body is subjected two mutually perpendicular principal Tensile Stresses Accompanied by a simple shear stress.

Consider a rectangular body subjected to two mutually perpendicular principal tensile stresses of unequal intensities accompanied by a simple shear stress. It is required to find the resultant stress on an oblique plane.

Let σ_1 = Major tensile stress

σ_2 = Minor tensile stress and

τ = Shear stress across face BC and AD

θ = Angle made by the oblique plane with the axis of minor tensile stress.

According to the principle of shear stress, the faces AB and CD will also be subjected to a shear stress of τ

Mohr's Circle is drawn as follows:

Take any point A and draw a horizontal line through A. Take $AB = \sigma_1$ and $AC = \sigma_2$ towards right from A to some suitable scale. Draw perpendiculars at B and C and cut off BF and CG equal to shear stress τ to the same scale. Bisect BC at O. Now with O as centre and radius equal to OG or OF draw a circle. Through O, draw a line OE making an angle 2θ with OF as shown in Fig.

From E, draw ED perpendicular on CB. Join AE. Then the normal and tangential stresses on the oblique plane are given by AD and ED respectively. The resultant stress on the oblique plane is given by AE

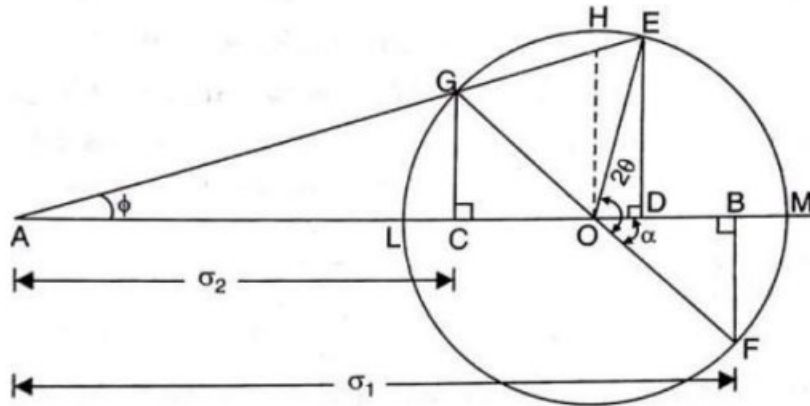

From Fig.

Length AD = Normal stress on oblique plane

Length ED = Tangential stress on oblique plane.

Length AE = Resultant stress on oblique plane.

$$\text{Radius of Mohr's circle} = \frac{\sigma_1 - \sigma_2}{2}$$

Angle θ = obliquity

Problem 1.27. A rectangular block of material is subjected to a tensile stress of 65N/mm^2 on one plane and a tensile stress of 35N/mm^2 on the plane right angles on the former. Each of the above stresses is accompanied by a shear stress of 25N/mm^2 . Determine the Normal and Tangential stress a plane inclined at 45° to the axis of major stress.

Given Data

Major principal stress, $\sigma_1 = 65\text{N/mm}^2$

Minor principal stress, $\sigma_2 = 35\text{N/mm}^2$

Shear stress, $\tau = 25\text{N/mm}^2$

Angle of oblique plane with the axis of minor principal stress,

$$\theta = 90^\circ - 45^\circ = 45^\circ$$

To Find

The Normal stress and Tangential stress.

Solution

Scale. Let $1\text{cm} = 10\text{N/mm}^2$

STRENGTH OF MATERIALS

Then $\sigma_1 = \frac{65}{10} = 6.5\text{cm}$,
 $\sigma_2 = \frac{35}{10} = 3.5\text{cm}$ and
 $\tau = \frac{25}{10} = 2.5\text{cm}$

Mohr's circle is drawn as:

Take any point A and draw a horizontal line through A on both sides of A as shown in fig. Take $AB = \sigma_1 = 6.5\text{cm}$ and $AC = \sigma_2 = 3.5\text{cm}$ towards right of A to some suitable scale. Draw perpendiculars at B and C and cut off BF and CG equal to shear stress $\tau = 2.5\text{cm}$ to the same scale. Bisect BC at O. Now with O as centre and radius equal to OG or OF draw a circle. Through O, draw a line OE making an angle 2θ (i.e $2 \times 45 = 90$) with OF as shown in Fig.

From E, draw ED perpendicular on CB. Join AE. Then the normal and tangential stresses on the oblique plane are given by AD and ED respectively. The resultant stress on the oblique plane is given by AE

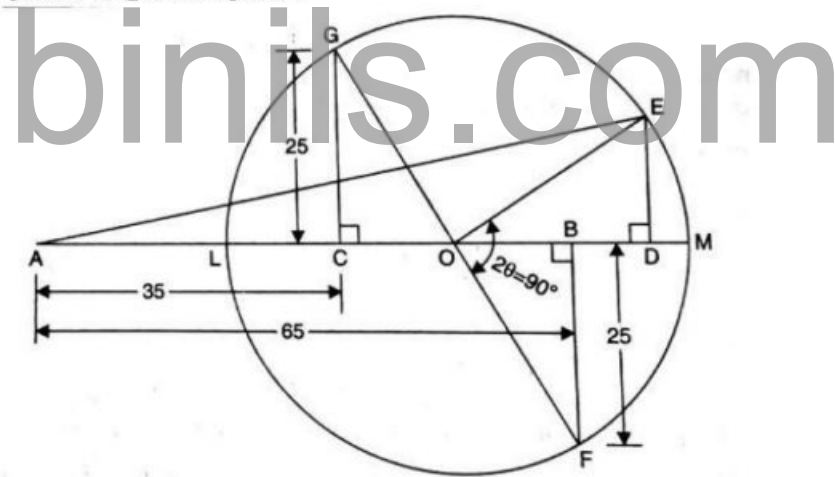

By measurements :

Length AD = 7.5 cm and

Length ED = 1.5 cm

Then normal stress = Length AD × Scale
 $= 7.5 \times 10 = 75\text{N/mm}^2$

Tangential or shear stress = Length ED × Scale
 $= 1.5 \times 10 = 15\text{ N/mm}^2$.

IMPORTANT TERMS

Stress(σ)	$\sigma = \frac{p}{A}$	$p = \text{Load}$ $A = \text{area of cross section}$
Strain(e)	$e = \frac{dl}{l}$	$dl = \text{change in length}$ $l = \text{original length}$
Lateral strain	$= \frac{dd}{d} = \frac{dt}{t} = \frac{db}{b}$	$d = \text{diameter}$ $t = \text{thickness}$ $b = \text{width}$
Young's Modulus(E)	$E = \frac{\sigma}{e}$	$\sigma = \text{stress}$ $e = \text{strain}$
Shear modulus (or) Modulus of rigidity(C)	$C = \frac{\tau}{\phi}$	$\tau = \text{shear stress}$ $\phi = \text{shear strain}$
Total change in length of a bar	$dl = \frac{p}{E} \left[\frac{L_1}{A_1} + \frac{L_2}{A_2} + \frac{L_3}{A_3} + \dots \right]$	For same material ($E = \text{same}$) with different length and diameter
Total change in length	$dl = p \left[\frac{L_1}{A_1 E_1} + \frac{L_2}{A_2 E_2} + \dots \right]$	For different material with different length and diameter
For composite bar	Total load $P = p_1 + p_2 + \dots$ Strain $e_1 = e_2 = \dots$ Change in length are same	
Total change in length of uniform taper rod	$dl = \frac{4 P L}{\pi E d_1 d_2}$	$P = \text{load act on the section}$ $L = \text{length of the section}$ $E = \text{Young's modulus}$ $d_1, d_2 = \text{larger \& smaller dia.}$
Total change in length of uniform taper rectangular bar	$dl = \frac{P L}{E t (a - b)} \log_e \frac{a}{b}$	$t = \text{thickness of bar}$ $a = \text{width at bigger end}$ $b = \text{width at smaller end}$
Factor of safety	$F.S = \frac{\text{Ultimate Stress}}{\text{Working Stress}}$	
Poisson's ratio(μ)	$\mu = \frac{\text{Lateral strain}}{\text{Linear strain}}$	$e_{latl} = \mu \times e$
For three dimensional stress system	$e_1 = \frac{\sigma_1}{E} - \mu \frac{\sigma_2}{A_2} - \mu \frac{\sigma_3}{A_3}$	Similar for other direction
Total change in length due to self-weight	$dl = \frac{wl^2}{2E}$	$w = \text{weight per unit volume of bar}$
Volumetric strain(e_v)	$e_v = \frac{dl}{l} (1 - 2\mu)$	For one dimension rectangular bar
=	$e_v = \frac{1}{E} (\sigma_x + \sigma_y + \sigma_z) (1 - 2\mu)$	For three dimension cuboid $\sigma_x = \frac{\text{Load in x direction}}{\text{Area in x direction}}$ Similar for $\sigma_y \sigma_z$
=	$e_v = \frac{dl}{l} - 2 \frac{dd}{d}$	For cylindrical rod

STRENGTH OF MATERIALS

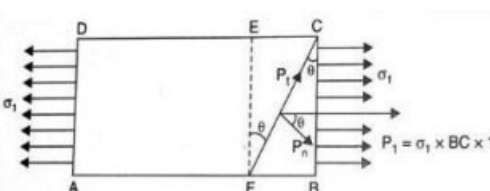
Bulk modulus(K)	$K = \frac{\sigma}{(dV/V)}$	
Relation between elastic constant E, K, C	$E = 3K(1 - 2\mu)$ $E = 2C(1 + \mu)$	
PRINCIPAL STRESSES AND STRAINS		
<i>A member subjected to a direct stress in one plane</i>		
Direct stress(σ)	$\sigma = \frac{P}{A}$	<p>P = load applied A = area of cross section θ = angle of oblique plane with the normal cross section of the bar</p>  <p style="text-align: center;">$\tau = \text{shear stress}$</p>
Normal stress	$\sigma_n = \sigma \cos^2 \theta$	
Tangential (or) shear stress	$\sigma_t = \frac{\sigma}{2} \sin 2\theta$	
Max. Normal stress	$= \sigma$	
Max. shear (or) Tangential stress	$= \frac{\sigma}{2}$	
<i>A member subjected to two like stress in mutually perpendicular direction</i>		
Normal stress	$\sigma_n = \frac{\sigma_1 + \sigma_2}{2} + \frac{\sigma_1 - \sigma_2}{2} \cos 2\theta$	<p>$\sigma_1 = \text{Major tensile stress}$ $\sigma_2 = \text{Minor tensile stress}$ $\theta = \text{angle of oblique plane with the normal cross section of the bar}$</p> <p><u>When compressive stress put - ve sign</u></p> <p><u>When tensile force is given, we have to find tensile stress = force/that cross section area</u></p>
Tangential (or) shear stress	$\sigma_t = \frac{\sigma_1 - \sigma_2}{2} \sin 2\theta$	
Resultant stress	$\sigma_R = \sqrt{\sigma_n^2 + \sigma_t^2}$	
Position of obliquity	$\phi = \tan^{-1} \frac{\sigma_t}{\sigma_n}$	
Max. shear stress	$(\sigma_t)_{max} = \frac{\sigma_1 - \sigma_2}{2}$	
<i>A member subjected to two like stress in mutually perpendicular direction with shear stress</i>		
Normal stress	$\sigma_n = \frac{\sigma_1 + \sigma_2}{2} + \frac{\sigma_1 - \sigma_2}{2} \cos 2\theta + \tau \sin 2\theta$	<p>$\sigma_1 = \text{Major tensile stress}$ $\sigma_2 = \text{Minor tensile stress}$ $\theta = \text{angle of oblique plane with the normal cross section of the bar}$</p> <p><u>When compressive stress put - ve sign</u></p>
Tangential (or) shear stress	$\sigma_t = \frac{\sigma_1 - \sigma_2}{2} \sin 2\theta - \tau \cos 2\theta$	
Resultant stress	$\sigma_R = \sqrt{\sigma_n^2 + \sigma_t^2}$	

Position of principal plane	$\tan 2\theta = \frac{2\tau}{\sigma_1 - \sigma_2}$	<p>When tensile force is given, we have to find tensile stress = <u>force/that cross section area</u></p> <p>When inclined stress is given it should be resolved into tensile stress and shear stress</p>
Max. shear (or) Tangential stress	$(\sigma_t)_{max} = \sqrt{\left(\frac{\sigma_1 - \sigma_2}{2}\right)^2 + \tau^2}$	
Position of max. shear (or) Tangential stress	$\tan 2\theta = \frac{\sigma_2 - \sigma_1}{2\tau}$	
Major principal stress	$\frac{\sigma_1 + \sigma_2}{2} + \sqrt{\left(\frac{\sigma_1 - \sigma_2}{2}\right)^2 + \tau^2}$	
Minor principal stress	$\frac{\sigma_1 + \sigma_2}{2} - \sqrt{\left(\frac{\sigma_1 - \sigma_2}{2}\right)^2 + \tau^2}$	
Mohr,s Circle		
<p>A body subjected to two mutually perpendicular principal tensile stresses</p> <p>Step1: select suitable scale</p> <p>Step2: to draw a horizontal line AB = σ_1</p> <p>Step3: to draw AC = σ_2</p> <p>Step4: draw a circle with BC as diameter with O as centre</p> <p>Step4: draw a line OE making an angle 2θ with OB</p> <p>Step5: from E to draw ED perpendicular to AB</p> <p>Result:</p> <p>Length AD = Normal stress</p> <p>Length ED = Tangential (or) shear stress</p> <p>Length AE = Resultant stress</p> <p>Length OC = OB = Radius of mohr's circle = Max.shear stress</p> <p>Angle of obliquity = $2\theta = \angle EAD$</p>		
<p>A body subjected to two mutually perpendicular principal tensile stresses which are unlike (Tensile and compressive)</p>		

STRENGTH OF MATERIALS

All the above procedure are same but *step3* will be varied. Because for compressive stress is in -ve sign, hence to draw a line AC in negative direction

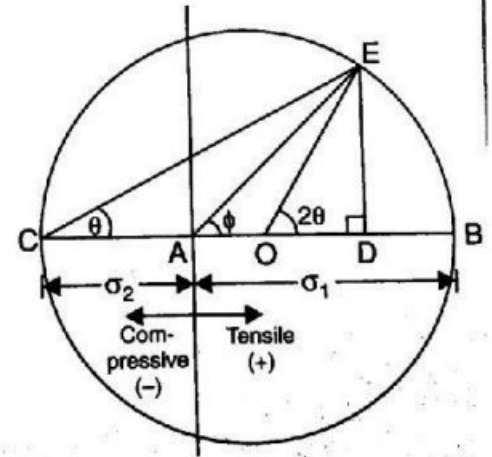

A body subjected to two mutually perpendicular principal tensile stresses with simple shear stress

Step1: select suitable scale

Step2: to draw a horizontal line $AB = \sigma_1$

Step3: to draw $AC = \sigma_2$

Step4: draw a perpendicular at B and C as BF and CG = τ

Step5: joint the point G & F which intersect line BC at O.

Step6: draw a circle with O as centre and $OG = OF$ as

radius. Step7: draw a line OE making an angle 2θ with OF

Step8: from E to draw ED perpendicular to AB

Result:

Length AD = Normal stress

Length ED = Tangential (or) shear stress

Length AE = Resultant stress

Length OG = OF = Radius of mohr's circle = Max.shear stress

Angle of obliquity = $2\theta = \angle EAD$

Length AM= Max. Normalstress

Length AL =Min. Normal stress

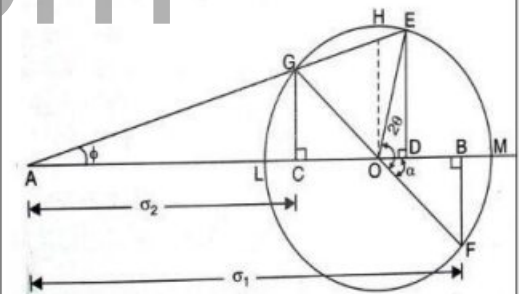
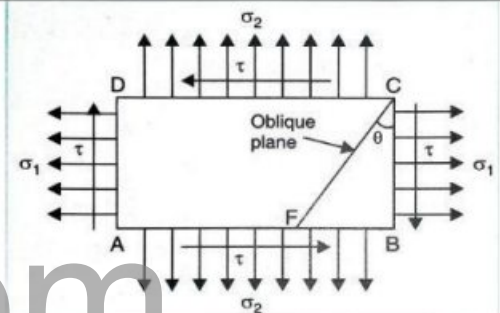

THEORETICAL QUESTIONS

TWO MARKS:

1. Define stress and its types
2. Define strain.
3. Define tensile stress and tensile strain.
4. Define the three Elastic moduli.
5. Define shear strain and Volumetric strain

6. A square steel rod $20 \text{ mm} \times 20 \text{ mm}$ in section is to carry an axial load (compressive) of 100 kN. Calculate the shortening in a length of 50 mm. $E = 2.14 \times 10^8 \text{ KN/M}^2$
7. Define Poisson's ratio.
8. What type of stress will be induced in a bar when the ends are restrained and subjected to i) rise in temperature and ii) a fall in temperature? .
9. Write down the relation between modulus of elasticity and modulus of rigidity and that between modulus of elasticity and bulk modulus.
10. When a rod of diameter 20mm is subjected to a tensile force of 40 kN, the extension is measured as 250 divisions in 200mm extension meter. Find the modulus of elasticity if each division is equal to 0.001mm.
11. What do you understand by the assumption, plane section remain plane even after the application of load?
12. When is a cylinder called as thin cylinder? What is the effect of this on stress distribution?
13. Write the expression for the determination of circumferential stress or hoop stress in thin cylinder.
14. Write the expression for the determination of Longitudinal stress in thin cylinder.
15. What is meant by 'Limit of proportionality'?

NUMERICAL PROBLEMS

1. A hollow cast – iron cylinder 4m long, 300 mm outer diameter and thickness of metal 50 mm is subjected to a central load on the top when standing straight. The stress produced is 75000 KN / m^2 . Assume Young's Modulus for cast iron as $1.5 \times 10^8 \text{ KN/m}^2$ and find
 - i. Magnitude of the load
 - ii. Longitudinal strain produced and
 - iii. Total decrease in length.
2. The following observations were made during a tensile test on a mild steel specimen 40 mm in diameter and 200 mm long. Elongation with 40 kN load (within limit of proportionality)

STRENGTH OF MATERIALS

$\delta l = 0.0304$ mm, yield load = 161 KN

Maximum load = 242 KN

Length of specimen at fracture = 249 mm.

Determine:

- i. Young's Modulus of Elasticity
- ii. Yield point stress
- iii. Ultimate stress
- iv. Percentage elongation.

3. A steel 2m long and 3 mm in diameter are extended by 0.75 mm when a weight W is suspended from the wire. If the same weight is suspended from a brass wire, 2.5 m long and 2 mm in diameter, it is elongated by 4.64 mm. Determine the modulus of elasticity of brass if that of steel be 2.0×10^5 N/n

4. A member formed by connecting a steel bar to an aluminium bar as shown in fig. Assuming that the bars are prevented from buckling sidewise; calculate the magnitude of force p_1 that will cause the total length of the member to decrease 0.25 mm. The values of elastic modulus of steel and aluminum are 2101 KN/mm^2 and 70 KN/mm^2

5. A steel tie rod 50 mm in ϕ and 2.5m long is subjected to a pull of 100 KN. To what length the rod should be bored centrally so that the total extension will increase by 15 % under the same pull, the bore being 25 mm ϕ ?

6. A steel flat plate AB of 1 cm thickness tapers uniformly from 10 cm to 5 cm width in a length of 40 cm. From first principles, determine the elongation of the plate, if an axial tensile force of 5000 kg acts on it. Take $E = 2.0 \times 10^6 \text{ kg/cm}^2$

7. A steel cube block of 50 mm side is subjected to a force of 6 KN (Tension), 8 KN (compressive) and 4 KN (tension) along X, y and z directions. Determine the change in the volume of the block. $e = 200 \text{ KN/mm}^2$ and $m = \frac{10}{3}$

8. A bar of 30 mm ϕ is subjected to a pull of 60 KN. The measured extension on gauge length of 200 mm is 0.09 mm and the change in diameter is 0.0039 mm. Calculate μ and the values of the three module.

9. At a point within a body subjected to two mutually perpendicular directions, the stresses are 80 N/mm^2 tensile and 40 N/mm^2 tensile. Each of the above stresses is accompanied by a shear stress of 60 N/mm^2 . Determine the normal stress. Shear stress and resultant stress on an oblique plane inclined at an angle of 45° with the axis of minor tensile stress.
10. A point in strained material is subjected to the stresses as shown in figure. Locate the principal planes and evaluate the principal stresses.
12. A metal bar $50 \text{ mm} \times 50 \text{ mm}$ section, is subjected to an axial compressive load of 500 KN . The contraction of a 200 mm gauge length is found to be 0.5 mm and the increase in thickness 0.04 mm . Find E and μ .
13. Steel bar is 900 mm long its two ends are 40 mm and 30 mm in diameter and the length of each rod is 200 mm . The middle portion of the bar is 15 mm in diameter and 500 mm long. If the bar is subjected to an axial tensile load of 15 KN , find the total extension. $E = 200 \text{ GN/m}^2$
14. A bar of 2 m length, 2 cm breadth and 1.5 cm thickness is subjected to a tensile load of 3000 kg . Find the final volume of the bar, if $\mu = \frac{1}{4}$ and $E = 2.0 \times 10^6 \text{ kg/cm}^2$
15. Determine the poisson's ratio and bulk modulus of a material, for which Young's modulus is $1.2 \times 10^5 \text{ N/mm}^2$ and modulus of rigidity is $4.5 \times 10^4 \text{ N/mm}^2$.
16. A bar of cross section $10 \text{ mm} \times 10 \text{ mm}$ is subjected to an axial pull of 8000 N . The lateral dimension of the bar is found to be changed to $9.9985 \text{ mm} \times 9.9985 \text{ mm}$. If the modulus of the rigidity of the material is $0.8 \times 10^5 \text{ N/mm}^2$, determine the poisson's ratio and modulus of elasticity.
17. Calculate the modulus of rigidity and bulk modulus of a cylindrical bar of diameter of 25 mm and length of 1.6 m , if the longitudinal strain in a bar during a tensile test is four times the lateral strain. Find the change in volume when the bar is subjected to a hydrostatic pressure of 100 N/mm^2 . Take $E = 1 \times 10^5 \text{ N/mm}^2$

STRENGTH OF MATERIALS

18. A bar is 30mm in diameter was subjected to tensile load of 54KN and the measured extension on 300mm gauge length was 0.112mm and change in diameter was 0.00366mm. Calculate poisson's ratio and value of the moduli.
19. A rectangular bar of cross sectional area 12000mm^2 is subjected to an axial load of 360N/mm^2 . Determine the normal and shear stresses on a section which is inclined at an angle of 30° with the normal cross section of the bar.
20. Two parallel walls 6 m apart, are stayed together by a steel rod 20 mm ϕ passing through metal plates and nuts at each end. The nuts are tightened home, when the rod is at a temp of 100°C . Determine the stress in the rod, when the temperature falls down 20°C if.
- The ends do not yield and
 - The ends yield by 1mm. $E = 2 \times 10^6 \text{ kg/cm}^2$ and $\alpha = 12 \times 10^{-6} / \text{C}$

binils.com