

GOVERNMENT OF TAMILNADU  
DIRECTORATE OF TECHNICAL  
EDUCATION CHENNAI – 600 025

**STATE PROJECT COORDINATION UNIT**

Diploma in Instrumentation and Control Engineering

Course Code: 1042

M – Scheme

e-TEXTBOOK

on

**PROCESS CONTROL INSTRUMENTATION**

for

V Semester DICE

Convener for ICE Discipline:

Dr.S.Rajakumari,  
Head of Department/ECE,  
Dr.Dharmambal Govt. Polytechnic College for Women,  
Tharamani, Chennai - 600 113

Team Members for Process Control Instrumentation:

Dr.P.Parvathy M.E.,Ph.D.,  
Lecturer (Sr.Gr.) / ICE,  
280, ADJ Dharmambal Polytechnic college,  
Nagapattinam – 611 001

Mrs.J.Bhuvaneswari B.E.,  
Lecturer / ICE,  
363 , Srinivasa Polytechnic College,  
Kalamavur,  
Pudukkottai- 622 502

Mrs. G.Dhivya B.E.,  
Lecturer / ICE,  
212, Nachimuthu Polytechnic College,  
Pollachi,  
Coimbatore – 642003

Validated By:

Mrs. J.RAMA  
REGIONAL OFFICIER 1V  
Directorate of Technical Education  
Guindy, Chennai – 600 02

[www.binils.com](http://www.binils.com)

Anna University, Polytechnic & Schools

**DETAILED SYLLABUS**  
**34251 - PROCESS CONTROL INSTRUMENTATION (M Scheme)**

**UNIT- I SIMPLE PROCESS CONTROL SYSTEMS AND TERMINOLOGY Pages 3-18**

Process – Continuous and Batch process – process variables Functional block diagram of an automatic process control system – set point – measured value – error - simple liquid level control system – flow control system – temperature control system with transportation lag – self regulation – Introduction to Piping and Instrumentation diagram-symbols for equipments, piping, instrumentation and control, P&ID diagram for simple liquid level control system.

**UNIT - II CONTROL PRINCIPLES**

**Pages 19-46**

Controller – reverse and direct action, controller modes discontinuous – ON-OFF Control with differential gap, without differential gap – continuous – proportional controller – proportional band (PB) – effect of PB on a controller output – offset – integral control – Derivative control - PI – PD-PID definition, salient features, applications and limitations of above controllers – selection of control action – electronic controllers – error detector – two position controller – P,I,D, PI, PD, PID controllers – pneumatic controllers for PID action – flapper nozzle mechanism, pneumatic relay.

**UNIT - III TUNING OF CONTROLLERS**

**Pages 47-53**

Concept of tuning – criteria for controller tuning – quarter Decay ratio, IAE, ISE, ITAE – methods of tuning – open loop response method – process reaction curve – closed loop response method – ultimate cycle method - damped oscillation method.

**UNIT - IV FINAL CONTROL ELEMENTS**

**Pages 54-78**

Signal converters – P to I converter, I to P converter – actuator – electrical, pneumatic, hydraulic–control valve – characteristics - quick opening, linear, equal percentage-pneumatic valve – solenoid valve –split range control valve – single seat and double seat plug – electric motor actuated control valve – control valve sizing – CV rating – selection of a control valve – effect of cavitation and flashing on control valve performance.

**UNIT - V COMPLEX CONTROL SYSTEMS**

**Pages 79-91**

Feed forward control system, Feed forward control of heat exchanger. comparison of feedback control system and feed forward control system. Ratio control – examples - Cascade control – cascade control of heat exchanger –cascade control of distillation column. Direct digital control(DDC) of single loop, Direct digital control with multiple control loops.

**REVISION AND TEST 10 Hrs.**

**REFERENCE BOOKS:**

1. Process control instrumentation technology by C.D.JOHNSON (Page No. 1-10, 440-476, 483-504, and 339-342)
2. Introduction to Process Engineering and Design by S B Thakore and B I Bhatt, Tata McGraw-Hill publishing company Limited, New Delhi(Page No. 43-44, 54-67)
3. Process control and Instrumentation by R.P. Vyas, Central Techno Publications, Nagpur second edition (Page no. 222-242, 254-258)

**REFERENCE WEBSITES:**

[http://en.wikipedia.org/wiki/PID\\_controller](http://en.wikipedia.org/wiki/PID_controller)  
[http://en.wikipedia.org/wiki/Control\\_valves](http://en.wikipedia.org/wiki/Control_valves)

**VIDEO LECTURES:**

<http://nptel.ac.in/courses>

<http://www.youtube.com/watch?v=vCCc2-qYS2A>

<http://freevideolectures.com/Course/3126/Process-Control-and-Instrumentation> <http://myopencourses.com/subject/process-control-and-instrumentation-2> [http://www.classiclearn.com/chemical-engineering/process-control-and-instrumentation-video\\_9569d1936.html](http://www.classiclearn.com/chemical-engineering/process-control-and-instrumentation-video_9569d1936.html)

[www.binils.com](http://www.binils.com)

# 34251 - PROCESS CONTROL INSTRUMENTATION (M Scheme)

## UNIT-1-SIMPLE PROCESS CONTROL SYSTEMS AND TERMINOLOGY

Process – Continuous and Batch process – process variables Functional block diagram of an automatic process control system – set point – measured value – error - simple liquid level control system – flow control system – temperature control system with transportation lag – self regulation – Introduction to Piping and Instrumentation diagram-symbols for equipments, piping, instrumentation and control, P&ID diagram for simple liquid level control system.

---

### 1.1 Process

In process control, the word process refers to continuous processes. Energy generation, electric power transmission and distribution systems, chemical and petrochemical industries, paper and pulp processing industries, food industries are examples for processes. A sequence of operations or actions is known as process. These sequences of operations will give a result or end product. Temperature, pressure, flow, and level are the important process variables. The performance of the process is measured from the process variables. Process control instrumentation improves quality control, efficiency, protection and safety. It removes isolated or hazardous atmosphere. Non-linear process, non-availability of sensors for accurately measuring the variables, time delay, inter-related multi-variables in the process, high sensitivity towards noise and disturbances are the difficulties in implementing process control.

To maintain or regulate the process variables at a constant, desired value is known as process control. From the given raw materials, a useful end product is produced by a series of actions. In some process there are more than one process variable. If only one variable is controlled in a process, then it is known as single-variable process. If more than one variable is controlled in a process, then it is known as multi-variable process. A process control system must:

1. Reduce outside load disturbances.
2. Increase the stability of process.
3. Optimize the performance of the process.

Process dynamics is the time response of the process when it is disturbed by load disturbances.

### 1.2 Continuous and batch processes:

The process in which the materials are stationary at one physical location is known as batch process. Idlies making in kitchen is an example of batch process. Steel melting in Bessemer converters, coke making in coke ovens, furnaces in foundries, batch reactors in chemical plants are examples for batch processes.

A process in which the materials flows more or less continuously through a plant apparatus while being manufactured or treated is termed a continuous process. Production of steam, production of power, continuously stirred tank reactors are some of the examples of continuous processes.

### 1.3 Functional block diagram of an automatic process control system:

Figure 1.1 shows the functional block diagram of an automatic process control system. The block diagram consists of functional elements like process, measuring element, comparator, controller, and final control element.

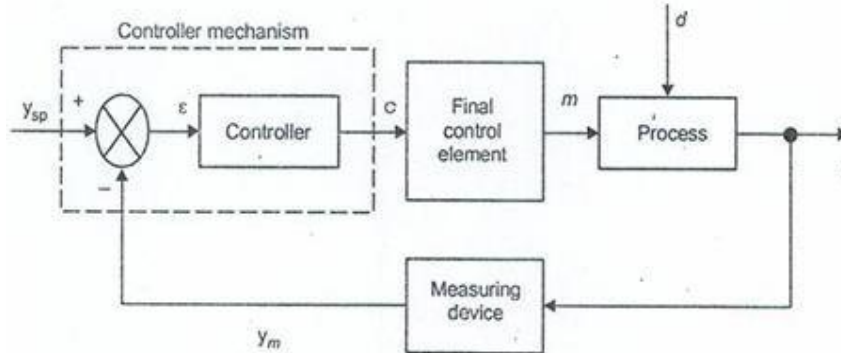

Figure 1.1 Functional block diagram of an automatic process control system

#### 1.3.1 Process

To produce an useful end product from the raw materials through a sequence of operations is known as process. The performances of the processes are determined by measuring some of the process variables (temperature, pressure, fluid, level).

#### 1.3.2 Measuring element

The variable which we want to control is called controlled variable. In order to control the variable, the present value of the variable is continuously measured using the measuring element. If we measure directly the controlled variable, then it is known as primary measurement. If the controlled variable cannot be measured directly, then other process variables which are reliable and easily measurable can be measured. Let  $c(t)$  be the controlled variable. In order to maintain the controlled variable at a constant value  $c(t)$  is measured. Measuring element must convert any physical quantity to be measured into electrical signal. The measuring element also includes a signal conditioning circuit to manipulate the measured electrical signal so that it is accepted by the next comparator stage.

#### 1.3.3 Comparator

The comparator has two input signals

- i) The measured controlled variable.
- ii) Set point (the set point has same units as measured value).

#### 1.3.4 Set point (desired value)

The value of the controlled variable required for the operator or for the application is known as set point. The comparator compares the measured variable with the set point and determines the difference in value as error.

$$\text{error} = \text{Setpoint} - \text{measured variable}$$

$$e(t) = r(t) - b(t)$$

Where

$r(t)$ =set point  
 $b(t)$ =measured variable  
 $e(t)$ =error

### 1.3.5 Controller

Error  $e(t)$  is the input to the controller. The controller has to determine how far the measured variable is deviated from the set point. It tries to keep the measured variable at the set point, so that error  $e(t)$  is zero. Controller output is given to final control element. The final control element changes the manipulated variable to keep the controlled variable at the set point.

### 1.3.6 Final control element

Final control element is in direct contact with the process. It is used to change the controlled variable. The output of the controller is given to final control element. After receiving the signal from the controller, depending on the control signal, it changes the process variable to get the desired set-point value.

### 1.4 Process variables

The process variables are classified based on how the performance of the process depends on the process variables

- i) Controlled variable
- ii) Manipulated variable
- iii) Disturbances

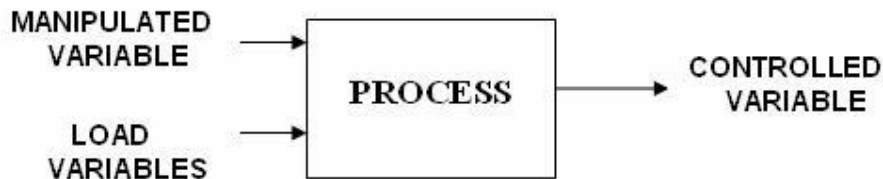

Figure1.2 Classification of process variables

All the process variables are classified into two types. They are input variables and output variables.

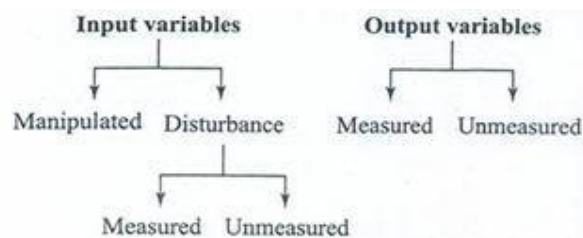

Figure1.3 Basic classification of process variables

**Input variables:** An input variable shows how the environment affects the process. Disturbances and manipulated variables are the input variables.

**Output variables:** An output variable shows how the process affects the environment. Measured and unmeasured variables are output variables. Output variables are to be controlled.

#### 1.4.1 Controlled variable

The variable which we use to maintain or regulate at constant value is known as controlled variable. Figure 1.4 shows the process variables in a process control system.

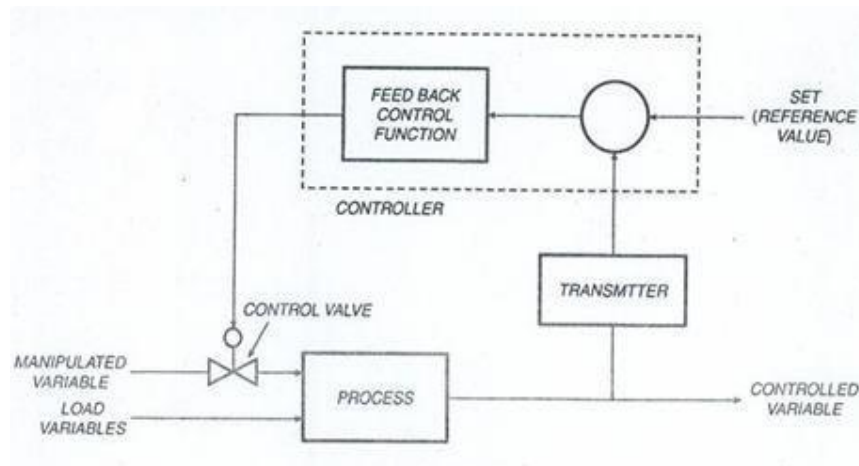

**Figure.1.4 An automatic process control system with process variables**

**Set point:** The desired/required value of the controlled variable is known as set-point.

#### 1.4.2 Manipulated variable

Manipulated variable is an input variable. Manipulated variable removes the changes in the controlled variable. The variable which affects the process in large scale with high speed is selected as manipulated variable.

#### 1.4.3 Disturbances

Due to changes in atmospheric pressure, room temperature etc, the quality and quantity of input variable changes, these variables are known as disturbances.

#### 1.4.4 Example

A continuously stirred tank heater is shown in Figure.1.5. The water in the tank is heated by passing steam. The tank is continuously stirred to keep all the points at the same temperature. The temperature of the inlet cold water to the tank is  $T_i$  and its flow rate is  $F_i$ . The temperature of the steam passing through the tank to heat the cold water is  $T_{st}$  and its flow rate is  $F_{st}$ . After heating, the hot water flow out of the tank with the temperature  $T_o$  and with the flow rate  $F_o$ . Since the water in the tank is continuously stirred the temperature of the water at the outlet  $T_o$  and the temperature of the water in the tank  $T$  are same. The level of the tank is  $h$ .

In the above process,  $F_i$ ,  $T_i$ ,  $F_{st}$ ,  $T_{st}$  are input variables.  $F_o$ ,  $T_o$  are output variables. Steam flow rate  $F_{st}$  is the manipulated variable. The process is to maintain the temperature of the tank water  $T$  at a constant value. Thus,  $T$  is the

controlled variable. To remove the changes in the controlled variable manipulated variable  $F_{st}$  is used. Either by increasing or decreasing the steam flow rate the controlled variable  $T$  is maintained at the set-point.  $F_i$ ,  $T_i$ ,  $T_{st}$  are disturbances. Any change in these variables affects the controlled variable.

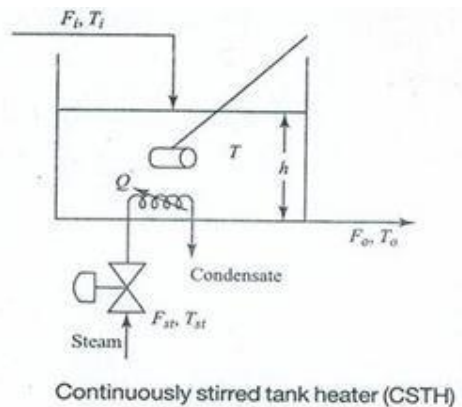

**Figure 1.5 Continuously stirred tank heater**

### 1.5 Advantages of automatic systems

- i) Increases the quality of product.
- ii) Large number of products can be produced.
- iii) Improvement in the consistency of the product dimension.
- iv) Mass production reduces the production cost.
- v) Reduces manual error.
- vi) Reduces human tension.
- vii) Saves energy.
- viii) Overall efficiency of the plant is increased.

### 1.6 Uses of automatic process control in industries

- i) Automatic process control instrumentation is used in heat treating, assembly operations of petroleum, chemical, steel, power and food industries.
- ii) Used in workflow, heat treating, assembly operations of automobile parts, refrigerators, TV, radio, and electronic equipments producing industries.
- iii) Used in transport systems like aeroplanes, railways, free missiles, ship etc.
- iv) Used in electric power supply units like compressors, pumps, prime movers for position, speed, and power control.



## 1.7 Simple liquid level control system

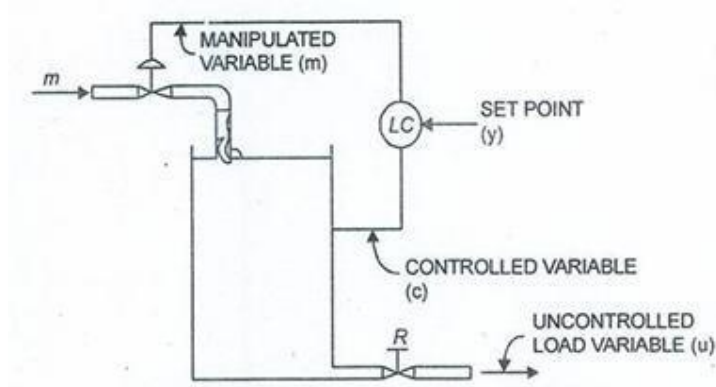

**Figure 1.6 Liquid level control system**

The figure 1.6 shows an automatic liquid level control system. The tank is used to store liquid. The controlled variable is level in the tank. The level is maintained at a constant value. The level transmitter (LT) is used to transmit the instantaneous values of level to the level controller (LC). The level controller receives the measured variable and compares it with the set point; based on the deviation it gives the control signal. The control signal is given to the final control element (the pneumatic control valve). If the level is below the set point, the control valve is open to fill the tank. If the level is above the set point the control valve is closed so that inlet flow is stopped. The manipulated variable is the inlet flow rate.

Let  $F_i$  = inlet volumetric flowrate ( $\text{m}^3/\text{s}$ )

$F_o$  = output volumetric flow rate ( $\text{m}^3/\text{s}$ )

$A$  = cross-sectional area ( $\text{m}^2$ )

$R$  = resistance to outlet flow caused by pipe, valve or weir, etc  
 $h$  = liquid head in the tank

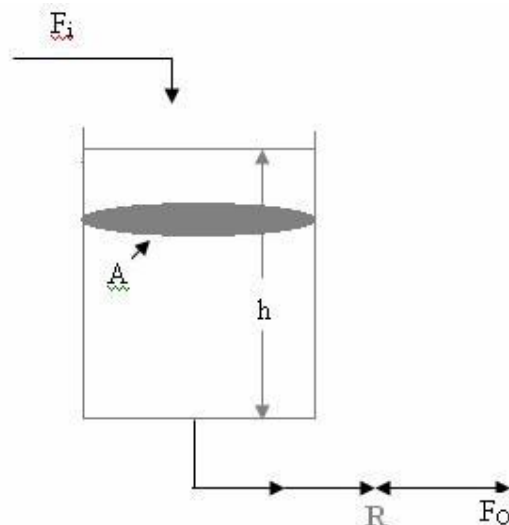

**Figure 1.7 Liquid level systems with first order lag**

If liquid level  $h$  in the tank is high, then outlet flow rate  $F_o$  is also high. Outlet flow rate  $F_o$  depends on level  $h$  of the tank. If outlet flow rate is resisted by a valve, it is denoted by  $R$ . The flow rate also reduces due to friction of water particles

with the pipe wall. The tank has a capacity to store water. The outlet flow rate is given by

$$F_o = \frac{h}{R} = \frac{\text{Driving force of flow}}{\text{Resistance to flow}}$$

Inlet flow rate ( $F_i$ )-Outlet flow rate( $F_o$ )=Rate of accumulation

$$AR \frac{dh}{dt} + h = RF_i$$

T=Time constant of the process=AR.

$K_p$ =R=steady state gain of the process.

A=Cross sectional area of the tank.

The storage capacity of the tank depends upon the area of the tank. Thus, time constant is the product of storage capacitance and resistance.

T=storage capacitance × resistance.

Level is measured using capacitance level transducer, bubbler tube, and/or displacer tube. The level of the tank  $h$  is the controlled variable. By changing the inlet flow  $F_i$ , the level is maintained at constant value. Inlet flow  $F_i$  is the manipulated variable. The level in the tank is transmitted by a level transmitter to the level controller. Based on the error, the controller opens or closes the control valve and maintains the level at the set point. In industries, the tanks bottom and top pressure values are connected to a differential pressure transmitter to measure the level.

### 1.8 Simple flow control system

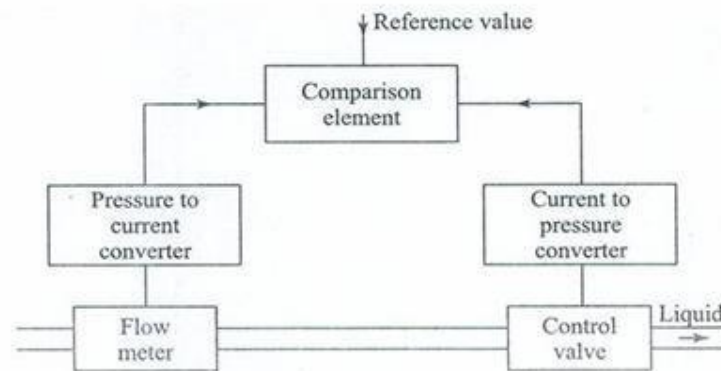

Figure 1.8 Flow control system.

In order to control flow of the fluid in a closed pipeline a throttling valve is used. The volumetric flow rate  $Q$  is given by

$$Q = C_d A \sqrt{2g(P_1 - P_2)}$$

Where,

$Q$ =Volumetric flow rate ( $m^3/sec$ )

$C_d$ =Flow co-efficient

$A$ =Area of cross section

$P_1$ =Upstream pressure  
 $P_2$ =Downstream pressure  
 $g$ =Gravitational constant

The fluid flow in the pipe can be measured using an orifice, venturi or flow nozzle, etc.  $P_1$  and  $P_2$  will change depending upon the flow. All the other variables are constant for a specific pipe dimensions. It is a direct process. By changing the position of the throttling valve, the flow can be changed.

Lag is minimum in flow processes. The flow rate will immediately change for every control valve position. Speed of response is high in flow control system. For a step input disturbance, the flow control system will reach the output step point within less than 1 second. More fluctuations (noise) will be there in flow systems. These fluctuations can be noted when a manometer is used along with the Orifice plate and in rotameter's bob. In industries, differential pressure transmitters(DPTs) are used to measure flow. When these DPTs are connected to orifice ( $P_1$ - $P_2$ ), they convert them into electrical signal and transmit it. The speed of response of transmitters is very high. The time constant of these electronic transmitters are approximately 0.2secs.

### 1.9 Simple Temperature control system

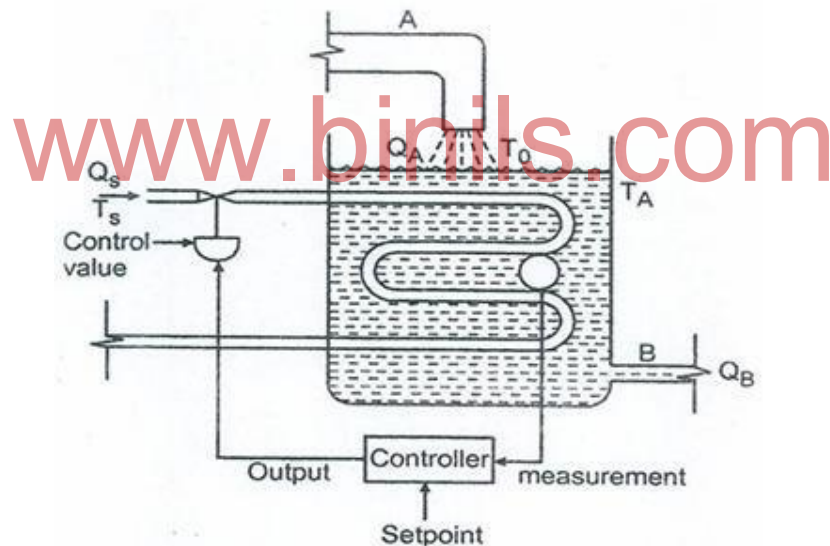

**Figure1.9 Temperature control system.**

Figure 1.9 shows a simple temperature control system. The temperature of the liquid in the tank is to be controlled. Hence, the controlled variable is the temperature of the liquid  $T_L$ .

Let

$Q_A$ = Input flow rate  
 $Q_B$ = Output flow rate  
 $T_A$ =Atmospheric temperature  
 $T_S$ =Steam temperature  
 $T_0$ =Inlet fluid temperature  
 $Q_S$ =Steam flow rate

The variable which directly affects the plant's productivity, safety, quality of the output product is selected as the controlled variable. The process input variable which directly affects the controlled variable is selected as the manipulated variable. In this temperature control system, if anyone of these variable changes then the liquid temperature will changes. To bring the liquid temperature to set-point, the steam flow rate has to be changed so that, heat to the process is increased. Any change in the uncontrolled variables, will upset the control system. These are load variables.

$$T_L = F(Q_A, Q_B, Q_S, T_a, T_s, T_o)$$

$T_a, Q_s, T_o, T_s$  are load variables. If the uncontrolled variables changes individually, then the controlled variables will deviate from the set point.

### 1.9.1 Process lag

If the controlled variable changes due to load disturbances, then the process control loop takes some specific time to do the corrective action. This is known as process lag. The period taken by the process to correct is known as process lag. For example: if the inlet flow is doubled (load change) the liquid temperature reduces. The temperature changes measured and steam inlet valve is opened, so that, excess of steam enters into the tank and brings back the liquid temperature to set-point, though the control loop functions faster. The control valve opens slowly. Steam flows faster into the tank but it takes some time for the liquid to reach the set-point. This time delay is due to the heating process itself.

### 1.9.2 Dead Time

The time taken in between error and the corrective action.

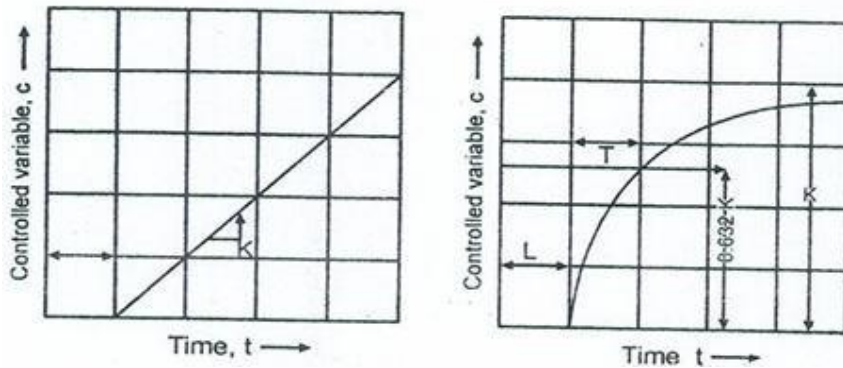

Figure 1.10 Response of process elements with dead time

### 1.9.3 Transportation lag

In figure 1.11, the liquid in the pipe near the steam flow will heat up immediately but the liquid at a distance from a pipe will heat up less because the liquid near the pipe must heat first and the liquid particles propagate the heat to the next point, it will take some seconds. This is known as transportation lag. The above time interval is known as dead time, transportation, pure delay or distance velocity lag. For better controller performance the system's dead time must be well known.

The dead time will change a stable control system into unstable control system. In Figure 1.11 (larger dead time), if the measuring element is placed at a distance from the outlet it will create a pure time delay.

For Example: The hot water flowrate is 10 feet/sec and if we place a measuring element at a distance 10 feet from the outlet point, then the dead time will be one second.

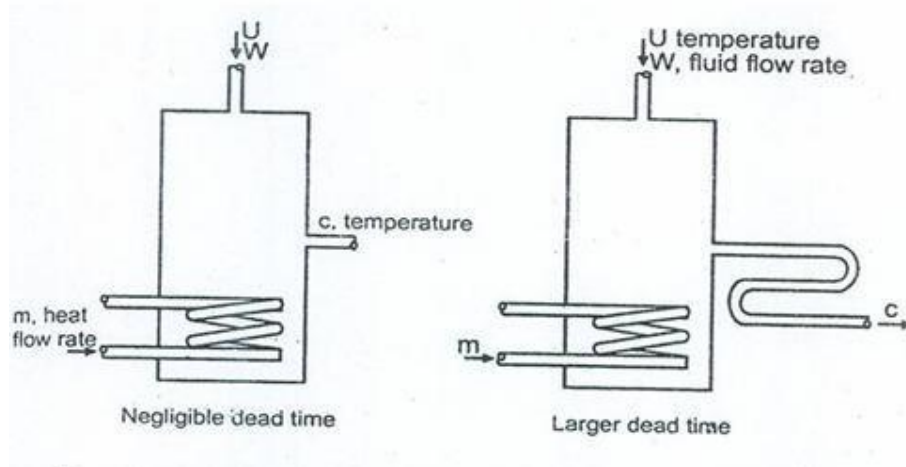

**Figure 1.11 Heating process with and without time lag.**

### 1.10 Self Regulation

Self regulation is a specific characteristic in a process. There are some processes even though the load is nominal without any control operations. The controlled variable is constant at some specific value. This is known as self regulation. Figure 1.9 has self regulation. The steam valve position is kept at 50% and the control loop is opened, so that the controller is disconnected. Steam in the tank will heat up to a point where input energy from steam flow and the liquid's energy are equal. If the load changes, it will attain a new temperature because the systems temperature is not controlled. In this condition, the process has self regulation. It will stabilize next temperature value.

#### 1.10.1 Process without self-regulation

In figure 1.7, If the liquid in the tank is pumped out in a specific rate using a pump (replace valve by pump). When the inlet flow rate is equal to outlet flowrate, the level in the tank will be at a fixed nominal value. If the inlet is slightly increased, the tank will not reach a new level. So, there is no self regulation. The process will become a pure capacity process.

### 1.11 Capacitance & Capacity

How much liquid can be stored in a tank without over flow is known as tank's capacity. In continuous process control systems, the tank must be designed to be short and broad, in order to avoid overflow and dry. If the cross sectional area of the tank is large, then the capacitance of the tank is more. A large capacitance tank is not affected by load disturbances easily. In large capacitance

tanks, the disturbances in the inflow won't affect the outflow. Capacitance will change depends on the current area covered by water.

$$A \frac{dh}{dt} = F_i - F_o$$

A=Capacitance (current area of water in the tank)

### 1.12 Piping and instrumentation diagram

Process control has symbols to represent the elements of a process control system. The process control diagram is known as piping and instrumentation drawing (P&ID) the symbols used are standards and are accepted by Instrument Society of America (ISA).

**Point of measurement:** The point in the process at which a measurement is or is made. The symbol is a thin line connected to a flow line or to a plant equipment outline. If not connected to an instrument symbol, an identifying letter shall be placed close to this to designate the measureable property.

**Instrument:** A device or combination of devices used directly or indirectly to measure, display, and control a variable. The symbol comprises of:

- i) A thin circle of approximately 10mm diameter.
- ii) A letter code showing the property measured and functions.
- iii) A number may be included to facilitate identification.

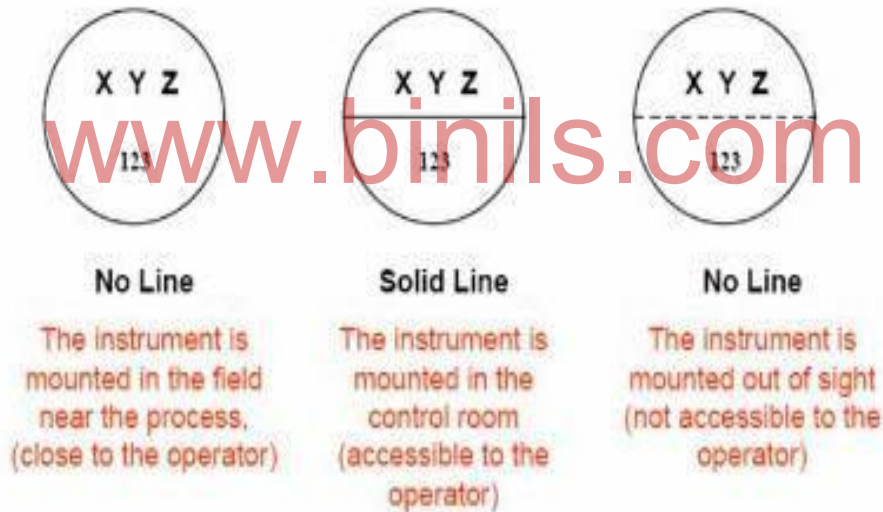

Figure 1.12 Instrument/Balloon symbol

**1.12.1 Panel mounted instrument:** An instrument that is mounted in a group normally accessible to the operator. The symbol is a thin line circle of approximately 10mm diameter with a horizontal line across it. This line may be located at any height within the circle. For an instrument mounted inside the control panel, the above symbol may include a second horizontal line. An instrument that is not panel mounted is known as locally mounted instrument.

**1.12.2. Identifying Letters:** The purpose of the instrument shall be defined by a letter code contained within the symbol circle; this letter code shall be constructed on the basis.



**First letter:** Shall denote the measured or initiating variable and shall be in accordance with column 2 of the table, but could be modified, if necessary, by the addition of a letter in accordance with column 3.

**Second letter:** Shall be in accordance with column 4. Where there are two or more succeeding letters, they shall be placed one after the other, in the sequence I R C T Q S Z A. The letter I may be emitted in case of a self indicating recorder.

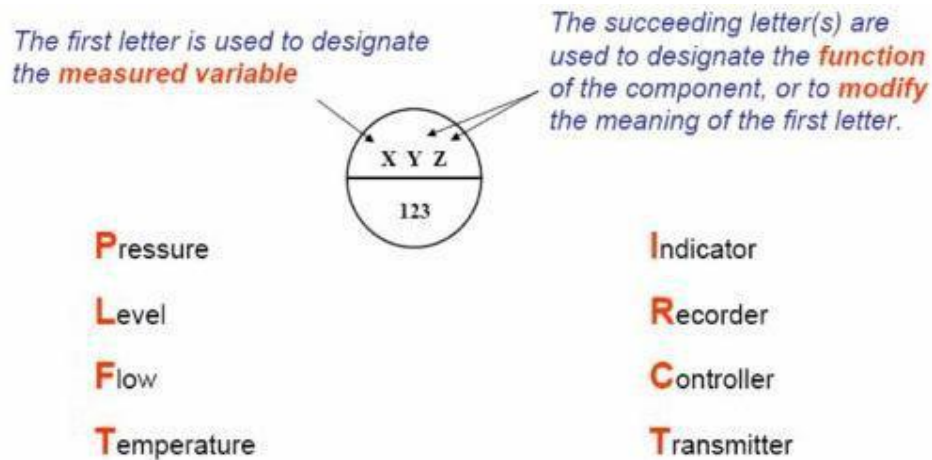

**Figure.1.13 Letter code**

The Instrument Society of America (ISA) publishes standards for symbols, terms and diagrams that are generally recognized throughout industry.

[www.binils.com](http://www.binils.com)

**TABLE 1.1 Letter code**

FIRST LETTER		SUCCEEDING LETTERS		
PROCESS VARIABLE	MODIFIER	READOUT	OUTPUT	MODIFIER
A. analysis		A alarm		
B. burner		*	*	*
C. conductivity			C controller	
D. density	D differential			
E. voltage		primary element		
F. flow	F ratio			
G. gauging		G glass		
H. hand				high
I. current		I indicator		
J. power	J scan			
K. time			K control station	

L. level		L light		low
M. moisture				middle
N. *	*	*	*	
O. *		O orifice		
P. pressure		P point		
Q. *	Q integrate			
R. radioactivity		R recorder		
S. speed	S safety		S switch	
T. temperature			transmitter	
U. multivariable		multifunction	multifunction	U multifunction
V. viscosity			V valve	
W. weight		W well		
X.				
Y. *			Y relay	
Z. position			Z drive	
* as desired				

Process control has symbols to represent the elements of the process control system. The process control diagram is known as piping and instrumentation drawing or P and ID. The symbols used are standards that have been developed through the years and are accepted by the Instrument Society of America.



### 1.12.3 Interconnections

Interconnections in a PID can involve many different types of signals and the flow

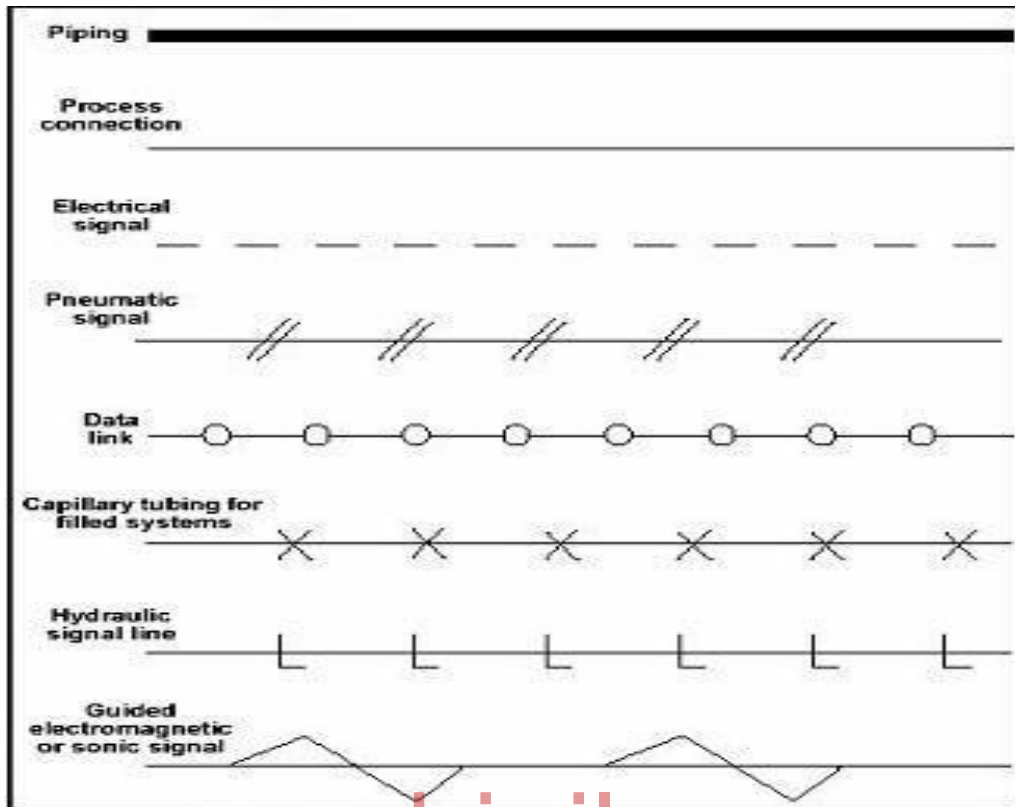

of the process itself. We use the symbol of a line to denote the nature of the signal.

**Figure 1.14 Piping and Connection symbols**

These symbols are used to identify how the instruments in the process connect to each other and the type of signal used.

### 1.12.4 P and ID diagram for simple liquid level control system

Figure 1.6 shows the P and ID diagram for simple liquid level control system

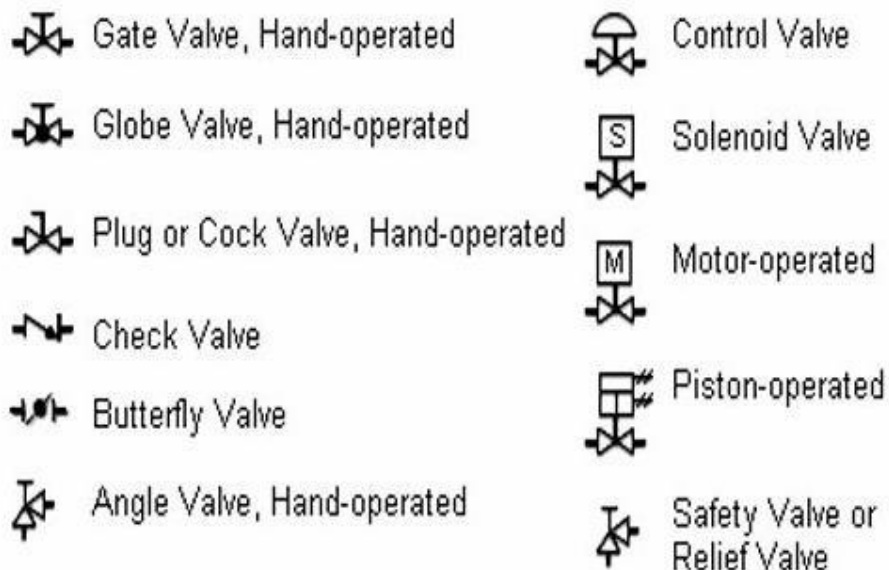

**Figure.1.15. Valve symbols**

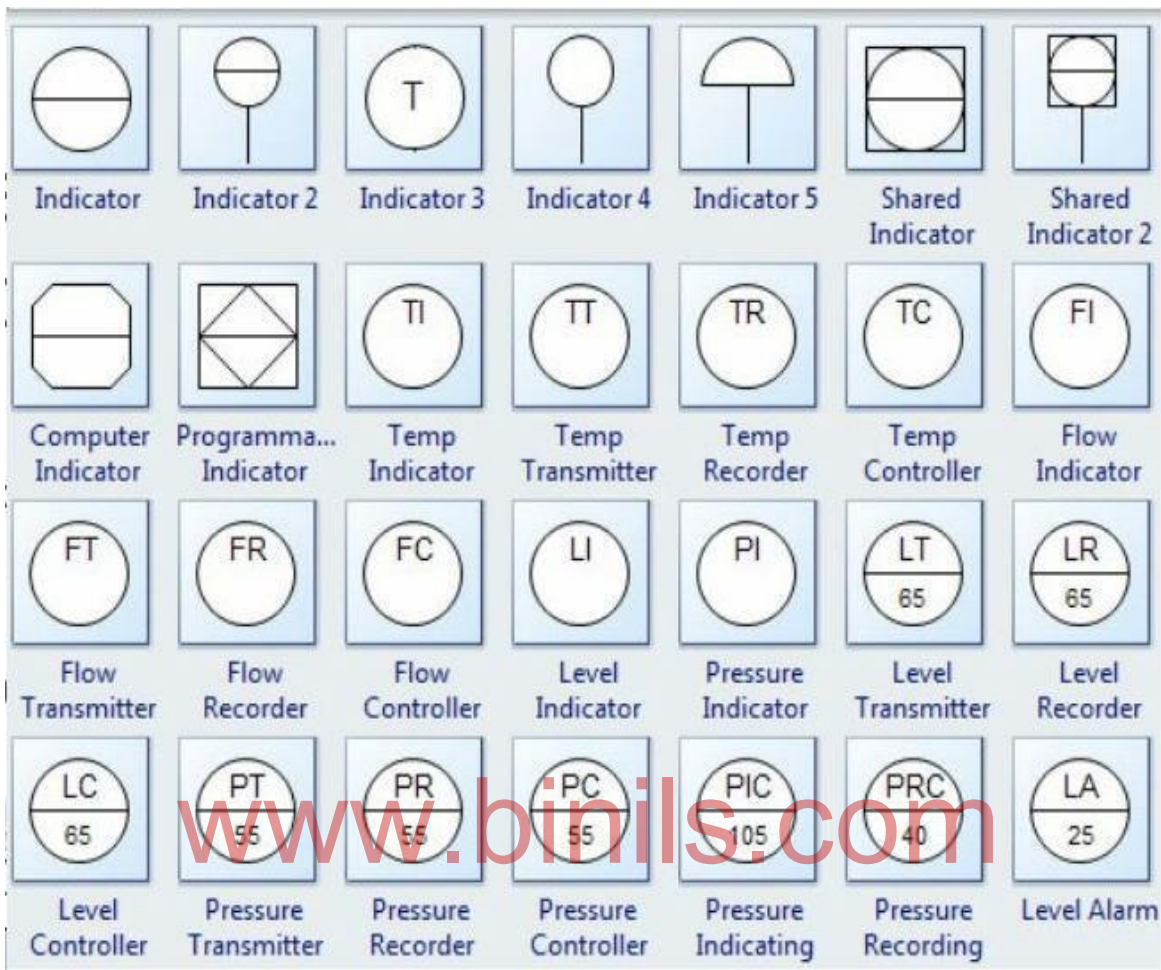

**Figure 1.16 Instrument symbols**

**Alarm:** A device which is intended to attract attention to a defined abnormal condition by means of discrete audible and are visible signal but which does not itself institute corrective action.

**REVIEW QUESTIONS:**

**Part A**

1. Define a process.
2. Define set-point.
3. Define measured variable.
4. What is comparator.
5. Define controlled variable.
6. Define manipulated variable.
7. Write any two advantages of automatic process control system.
8. Draw the functional block diagram of an automatic control system.
9. Define capacity & capacitance.
10. What is final control element.

11. What are disturbances.
12. What do you mean by transportation lag.
13. Draw the symbol for flow controller.
14. Draw the process line.

### **Part B**

1. Draw the P&ID drawing for simple liquid level control system.
2. Write short notes on transportation lag.
3. Write short notes on self regulation.
4. Write short notes on capacity and capacitance.
5. Write short notes on measured variable, controlled variable and manipulated variable.

### **Part C**

1. Explain with a neat sketch the functional block diagram of an automatic process control system and its functional elements.
2. With a neat sketch explain simple liquid level control system.
3. Explain flow control system with a neat sketch.
4. With a neat sketch explain temperature control system.
5. With an example explain controlled variable, manipulated variable and disturbance.

[www.binils.com](http://www.binils.com)

## UNIT II - CONTROL PRINCIPLES

Controller – reverse and direct action, controller modes – discontinuous – ON-OFF Control with differential gap, without differential gap – continuous – proportional controller – proportional band (PB) – effect of PB on a controller output – offset – integral control – Derivative control - PI -PD-PID definition, salient features, applications and limitations of above controllers – selection of control action – electronic controllers – error detector – two position controller – P,I,D, PI, PD, PID controllers – pneumatic controllers for PID action – flapper nozzle mechanism, pneumatic relay.

---

### 2.1 Automatic controller

An automatic controller determines the value of the controlled variable. It compares the actual value with the desired set value and calculates the deviation. It produces the counter action necessary to maintain the smallest possible deviation between desired set value and actual value.

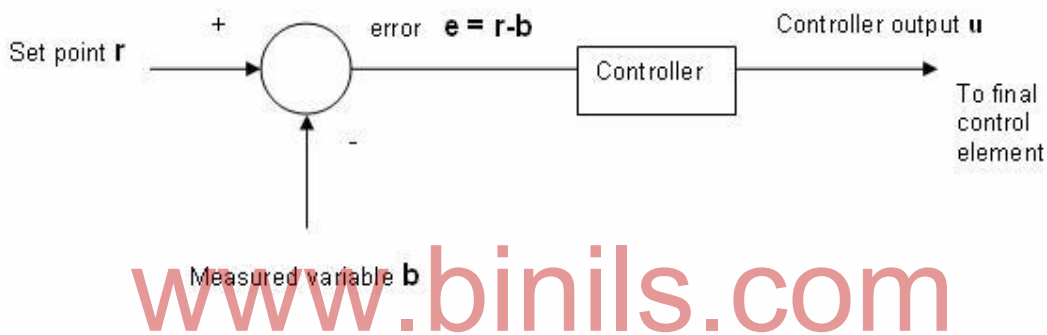

Figure 2.1 Block diagram of a Controller

### 2.2 Reverse and direct action

**Direct action:** When an increasing value of the controlled variable causes an increasing value of the controller output then it is said to be operating with direct action. Example: a level control system which outputs a signal to an output control valve. If the level rises control variable increases the controller output should increase to open the valve more to keep level under control.

**Reverse action:** When an increasing value of the controlled variable causes a decreasing value of the controller output then it is said to be operating with reverse action.

**Example:** Temperature control of a furnace with fuel as heat energy. If the temperature increases the controller output should decrease to close the valve for decreasing the input to bring the temperature under control.

**Direct action controller-** if control variable increases then the output of the controller increase.

**Reverse action controller-** if control variable increases then the output of the controller reduce.

On-off controller is reverse acting controller. When the process variable is higher than the set point, controller output is 0%. If measured value is higher than the set point, error is negative. Then, controller output starts reducing. In this case, when the control variable increases, the controller output is reducing. It is a reverse action.

A liquid level system is shown in figure 2.2. An inlet valve is placed in the inlet pipeline. LS is the limit switch which is used to sense the level in the water tank. An on-off controller is connected to the inlet valve. If the level is increased above the set point, the on-off controller closes the inlet valve i.e., if the control variable level increases, the controller output decreases to 0%. This is reverse acting controller.

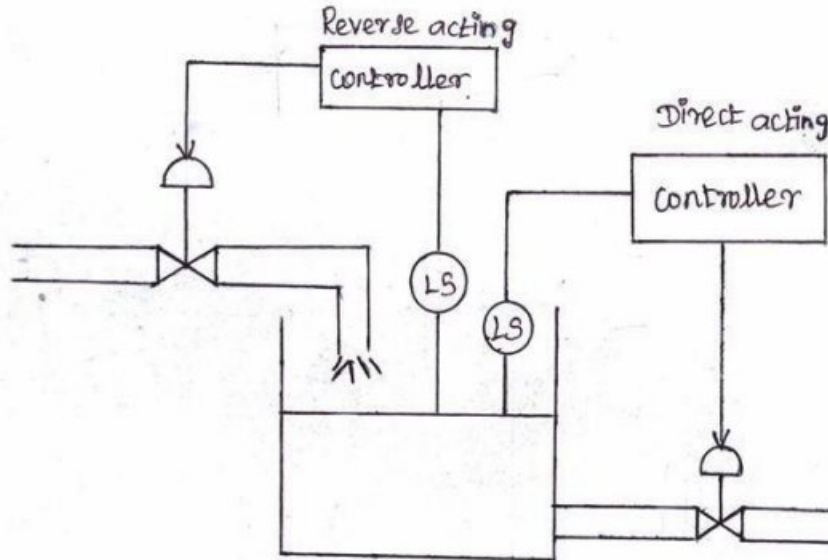

**Figure 2.2 Liquid level system- reverse/direct acting controller**

The other case, if the controller is used to control the outlet valve, it is direct acting. The valve is normally closed. If the level is increased above the set point, the direct acting controller gives an output to open the outlet valve when the controlled variable level increases, the controller output also increases to 100%. This is direct acting controller.

## 2.3 Controller modes

### 2.3.1 Mode of control

The method by which the automatic controller produces the counteraction is called the mode of control or control action. Controller is the most important part of the process control loop. Based on the deviation between desired set value and actual measured value the controller generates a control signal and gives it to the final control element. The input to the controller is the error  $e(t)$  which is a measured indication of how much the controlled variable  $c(t)$  has deviated from the set point  $r(t)$ . The output of the controller is a signal representing the action to be taken to reduce the error. Normally controller is some form of computer analog or digital, pneumatic or electronic which using the input measurement solves certain equations to calculate proper output. Inputs to the controller are measured indications of both the controlled variable and a set point representing the desired value of the variable expressed in the same fashion as the measurement. The controller output is the signal representing action to be taken when the measured value of the controlled variable deviates from the set point. The measured indication of a variable is denoted by  $b$ , while the actual variable denoted by  $c$ .

If a RTD (temperature sensor) is used to measure temperature. Then the actual variable is temperature in  $^{\circ}\text{C}$  but the measured indication is in resistance (ohms).

### 2.3.2 Error

The deviation of the controlled variable from the set point is error. Error ( $e$ ) is given by

$$e = r - b$$

where,

$e$ =error

$b$ =measured indication of variable

$r$ =set point variable or reference

In this equation error is expressed in units of the measured analog value of the control signal. To express error as percent of span

$$e_p = \frac{r - b}{b_{\max} - b_{\min}} \times 100$$

where

$b_{\max}$  = maximum of measured value.

$b_{\min}$  = minimum of measured value.

$e_p$  = error expressed as percent of span.

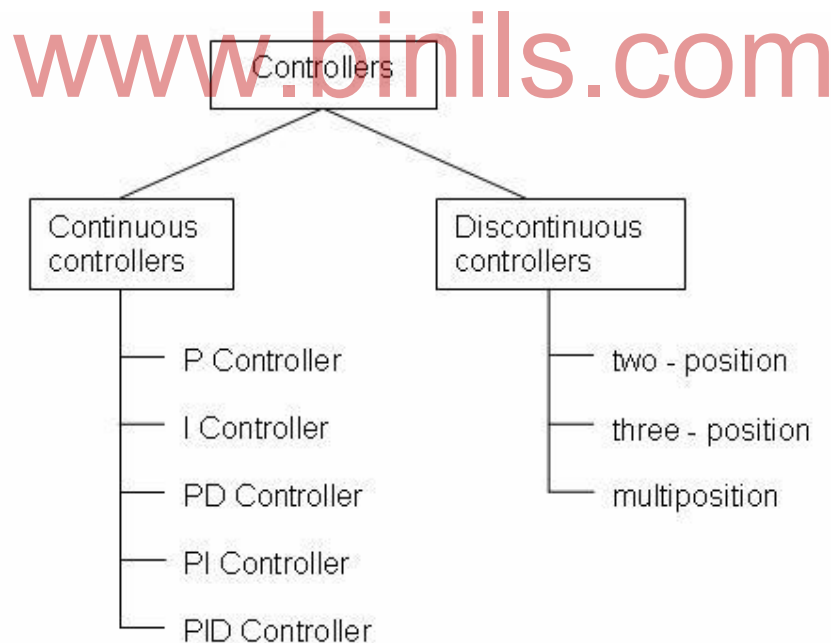

**Figure 2.3 Classification of controllers based on their modes of operations**

There are two types of controller modes namely discontinuous and continuous. In discontinuous modes, the controller gives a discontinuous or discrete change in the controller output. Example: two position (On-Off) mode controller, multi-position mode controller. In continuous mode, the controller gives a continuous change in the controller output. Example: Proportional, Integral, Derivative and Composite control



modes. In each mode, the output of the controller is described by a factor  $p$ .  $p$  is percent of controller output relative to its total range.

$$p = \frac{u - u_{min}}{u_{max} - u_{min}}$$

Where,

$p$  = controller output as percentage of full scale.

$u$  = value of the output.

$u_{max}$  = maximum value of controlling parameter.

$u_{min}$  = minimum value of controlling parameter.

## 2.4 Discontinuous controller modes

### 2.4.1 ON-OFF Control /Two position mode

$$p = \begin{cases} 0\% & e_p < 0 \\ 100\% & e_p > 0 \end{cases}$$

Two position controllers are commonly used in both industrial and domestic services. It is the simplest and cheapest control system. When measured variable is below the set point the controller is on and the output signal is maximum. When measured variable is above the set point the controller is off and output is zero.

Example: In domestic water heaters if the temperature drops below the set point the heater is turned on, if the temperature is above the set point the heater turned off. If error is positive, heater is on. If error is negative, heater is off.

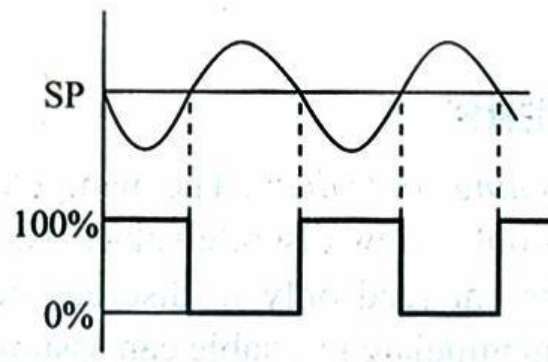

Figure 2.4 On off controller response without neutral zone

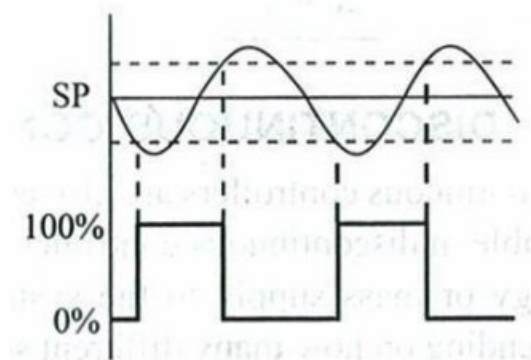

Figure 2.5 On-off controller response with neutral zone

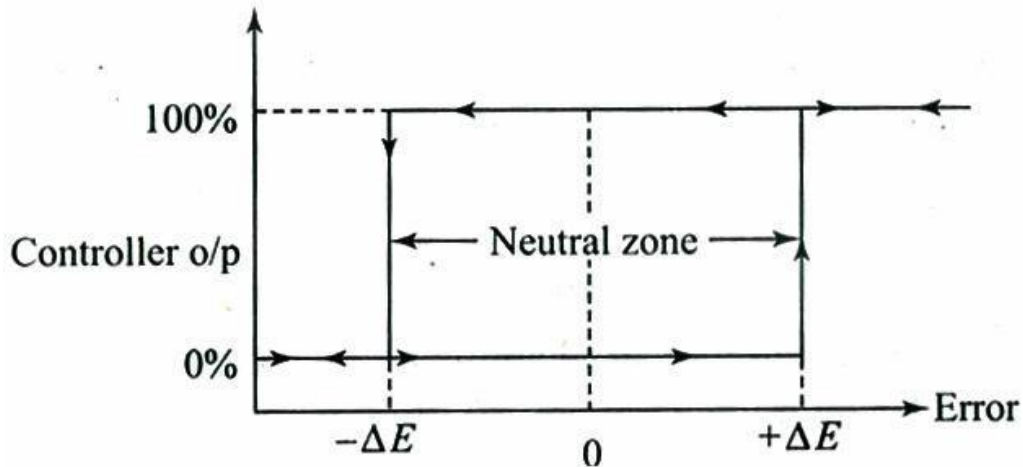

Figure 2.6 Output of on-off controller with neutral zone

To avoid frequent operation of on-off mechanism, a neutral zone or differential gap is kept. The range through which actuating error signal must move before switching occurs is called "differential gap". To prevent excessive cycling to reduce wear of components as well as to reduce arching at relay contacts neutral zone is purposely kept.  $\pm \Delta E$  is neutral zone. It is decided by the amount of accuracy required. During neutral zone, the output doesn't change. On-off action is suitable for the following conditions:

- i) Process response is low.
- ii) Load changes are low and small.
- iii) There is no transfer lag.
- iv) There is little or no dead time.

#### 2.4.2 ON-OFF Liquid level control system

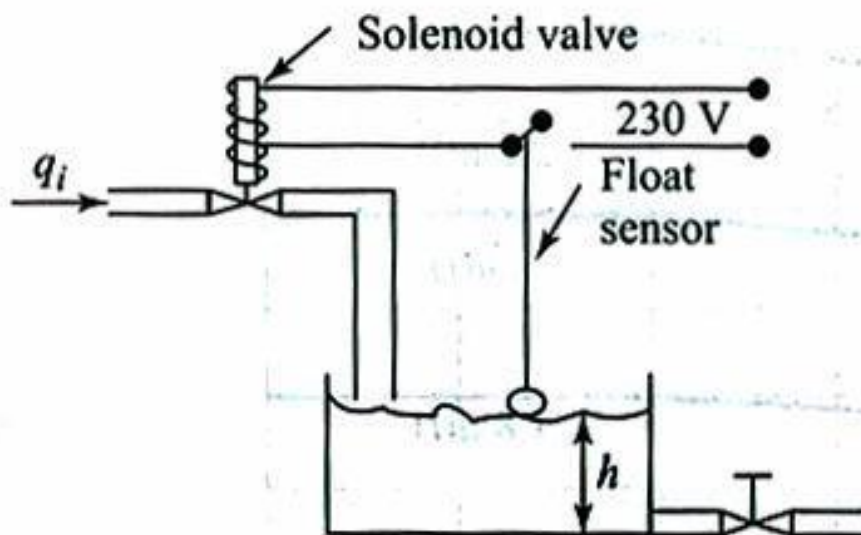

Figure 2.7 ON-OFF Liquid level control system



A liquid level control using two position is shown in figure 2.7, a float in the tank operates an electric switch which controls a solenoid valve. When the liquid level raises the switch contacts or closes, the solenoid valve closes and the inflow is cut-off. When the liquid level falls the switch contacts or opens, the solenoid valve opens and the inflow resumes. This phenomenon is graphically represented in the figure 2.6 which plots controller output versus error. The controller output will not change state, until increasing error changes by  $+\Delta E$  above 0 by decreasing the error must fall  $-\Delta E$  below 0 before the controller changes the 0% rating. The range  $2\Delta E$  is the neutral zone or differential gap. Neutral zone is purposely designed above a minimum quantity to prevent excessive cycling. Neutral zone is the desirable hysteresis in a system. During the differential gap the manipulated variable is maintained in the previous value.

### 2.4.3 Applications

Two position control modes are best suited for large scale systems with relatively slow process rates. It is used in room heaters, water heaters, refrigerator, and level control of water tanks, air conditioners, temperature and level control of large volume tanks.

### 2.5 Continuous controller modes

Continuous controller modes are an extension of discontinuous controller modes. Continuous controller modes are proportional (P), integral (I), differential (D) and their combinations. In continuous control modes, the relationship between controller output and error will be a continuous mathematical function.

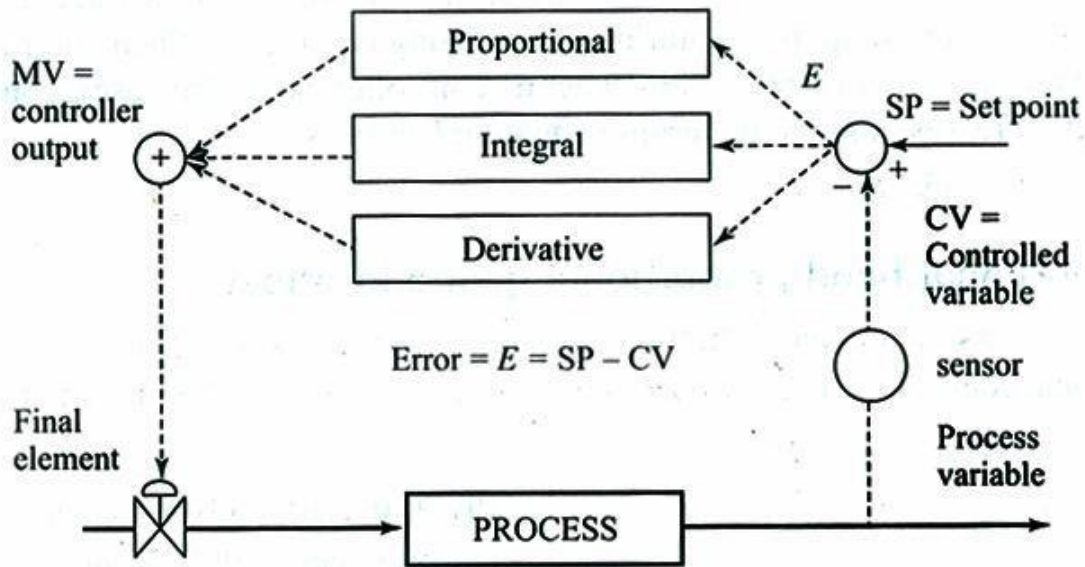
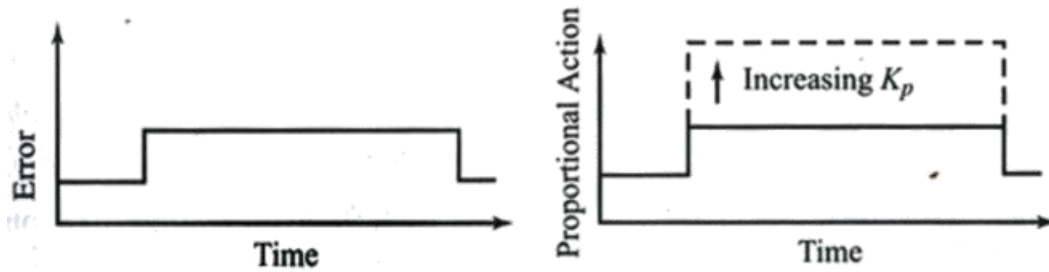

Figure 2.8 Closed loop model with various control modes



**Figure 2.9 Proportional action**

## 2.6 Proportional mode

In two position control mode, the controller output is either 0% or 100% depending on the error. In multi-position mode, more divisions of controller outputs are developed. The natural extension of multi-position control mode is proportional mode. In proportional mode, there is a smooth, linear relationship exist between the controller output and the error. In proportional action, there is a continuous, linear relation between the values of the deviation and manipulated variable.

### 2.6.1 Proportional gain and Proportional band

The proportional mode is expressed by the equation

$$p = K_p e_p + p_0$$

where

$K_p$ = proportional gain between error and controller output (%per%).

$P$ = controller output (%).

$e_p$ =error (%)

$P_0$ = controller output with no error (%).

The adjustable parameter of the proportional mode  $K_p$  is called the proportional gain or proportional sensitivity. Each value of the error has unique value of controller output. There will be a one-to-one correspondence. The range of error to cover 0%-100% controller output is called the proportional band (PB) because the one-to-one correspondence exists only for error in this range.

The proportional band is equal to the inverse of the proportional gain.

$$PB = \frac{100}{K_p}$$

The proportional band is defined as the range of error over which it must change in order to drive the actuating signal of the controller over its full range. A graph of the proportional mode output versus error is shown in figure 2.9. The proportional band depends on the gain. High gain means large response to error. The characteristics of proportional control mode are as follows:

1. If the error is 0, the output is a constant value equal to  $p(0)$ .
2. If there is error, for every 1% of error a correction  $K_p\%$  is added to or subtracted from  $p(0)$  depending on the reverse or the direct action of the controller.
3. There is a band of error about 0 of the magnitude PB within which

the output is not saturated at 0% or 100%.

### 2.6.2 Offset

Whenever a change in load occurs, the proportional control mode produces a permanent residual error in the operating point of the controlled variable which is known as “offset”. Offset can be minimized by large, constant  $K_p$  which also reduces the proportional band. Proportional control is used in processes with moderate to small process lag times.

### 2.6.3 Effect of PB on a controller output

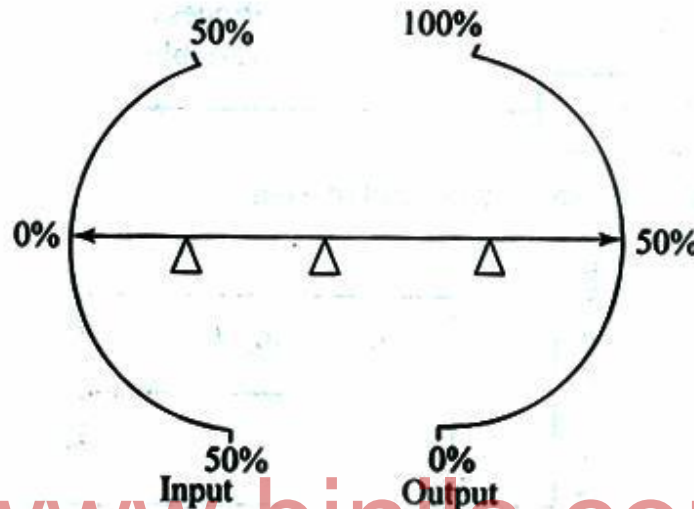

Figure 2.10 Proportional action with provision for changing

**PB Pivot at centre:**

If the input changes to 100%, then the output changes to 100% (PB=100%).

**Pivot to right:**

If the input changes to 100%, then the output changes to 50% only. To get 100% change in output, the input must be changed to 200%.

**Pivot to left:**

If input change is 50%, then the output change is 100% (PB =50%).

The range of error required to move the controller output from 0% to 100% is known as proportional band.

$$PB(\%) = \frac{100}{K_p}(\%)$$

where,

$K_p$ =proportional gain,

PB=proportional band.

These two are inversely proportional to each other. If proportional gain  $K_p$  increases, proportional band PB decreases. If proportional gain reduces, proportional band increases (sensitivity is less). If the value of  $K_p$  is very high, PB is very less. Then, proportional controller will act as on-off controller.

The steady state response of a proportional controller will have permanent steady state error. This error is known as offset.

No load condition:

If no load is applied to the process error is 0.

Under load condition:

If we load the process, the controller output will change, the error will change from 0, if the value of gain  $K_p$  increases, offset reduces.

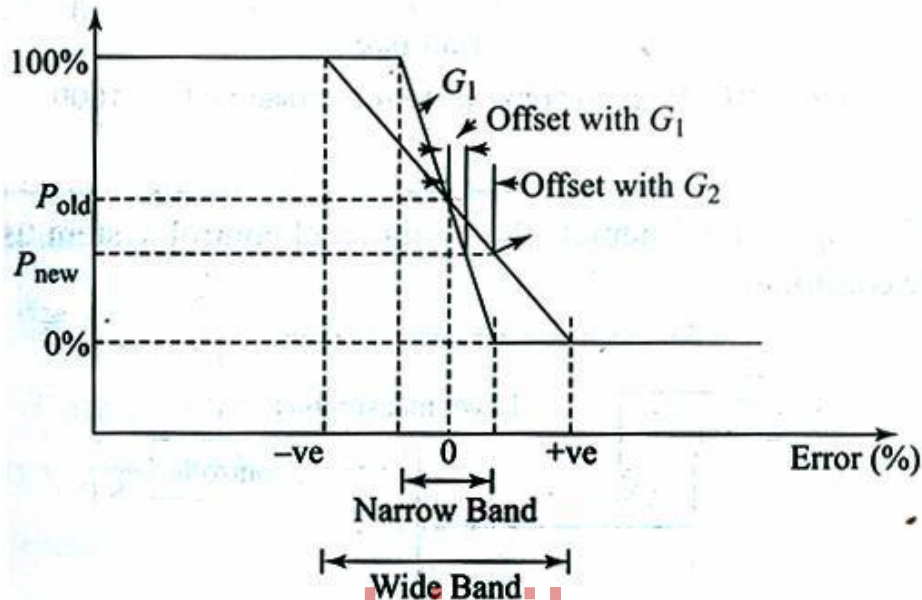

Figure 2.11 Proportional control exhibiting offset

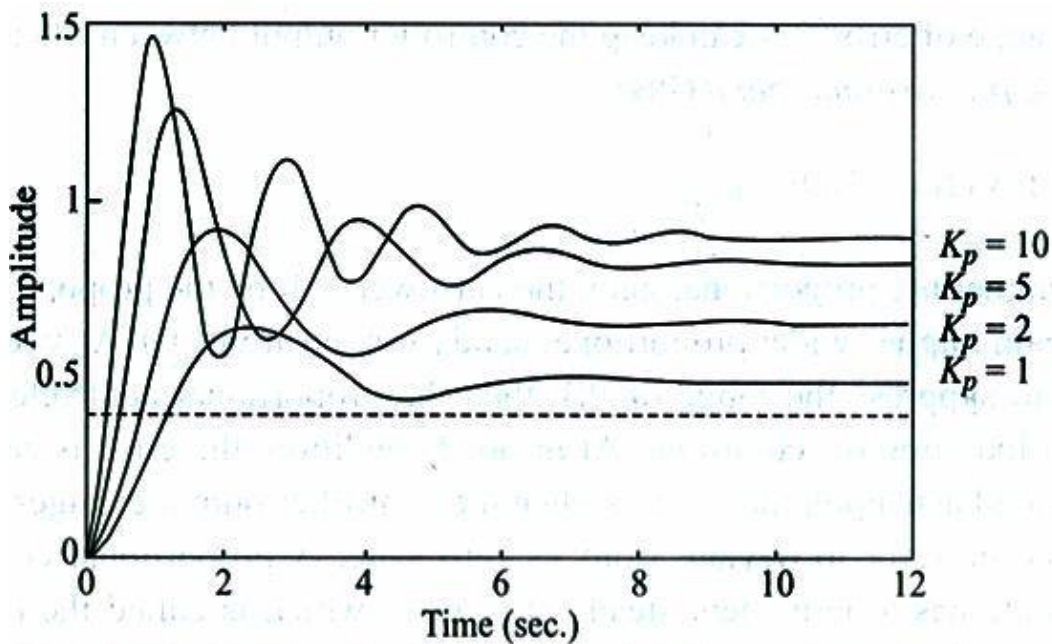

Figure 2.12 Step response of P-controller for various  $K_p$  values

## 2.7 Integral control mode (reset action mode)

In integral control mode, the value of the manipulated variable is changed at a rate proportional to the deviation. If the deviation is doubled, the final control element is moved twice as fast. When the controlled variable is at the set point, the deviation is 0. The final control element remains stationary. This control mode gives a continuous change in speeds depending on error. This mode is also known as reset action mode. This mode is expressed by the following equations;

$$\frac{dp}{dt} = K_I e_p$$

Where,

$\frac{dp}{dt}$  = rate of controller output change (% per sec)

$K_I$  = constant relating the rate to the error (% per sec/%)

The integral time  $T_I = \frac{1}{K_I}$  expressed in seconds or minutes.  $T_I$  is defined as

the time of change of controlled variable caused by a unit change of deviation. If we integrate the equation we can find the actual controller output at any time.

$$p(t) = K_I \int_0^t e_p(\tau) d\tau + p_{(0)}$$

$p_{(0)}$  = controller output at  $t=0$

[www.binils.com](http://www.binils.com)

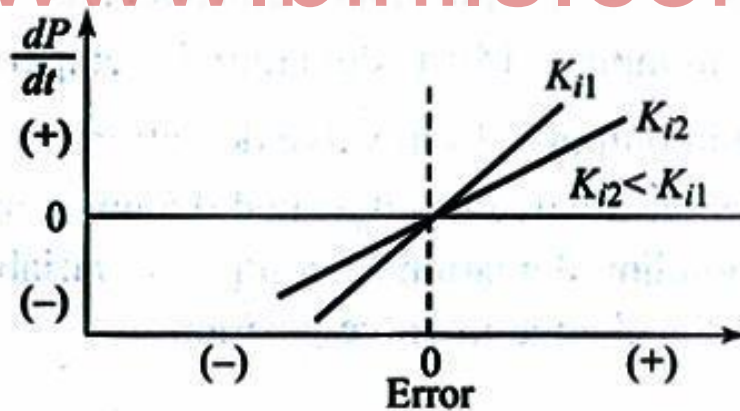

Figure 2.13 Input-output characteristics of integral mode

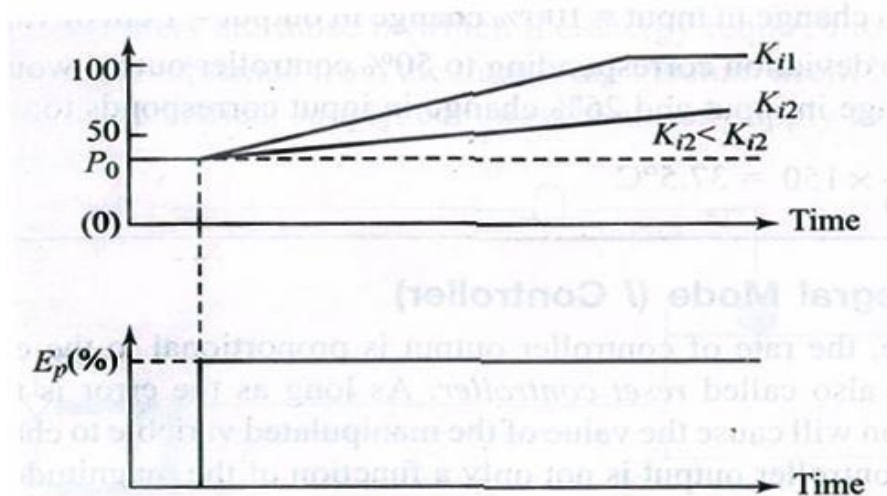

Figure 2.14 Response of integral mode to a constant

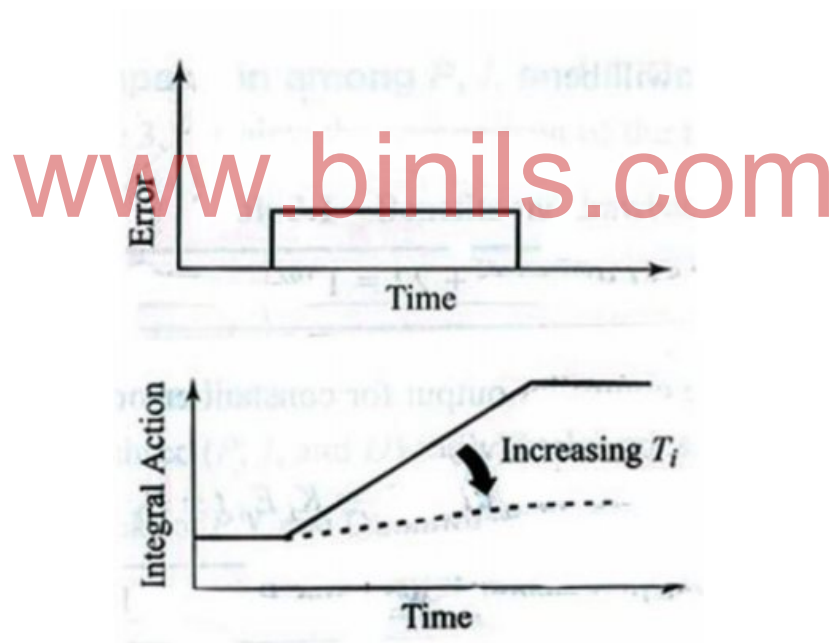

Figure 2.15 Integral controller response to a pulse input

Controller output  $x(t)$  depends on history of errors from  $t=0$ . If the error doubles the rate of controller output change also doubled. The characteristics of the integral mode are as follows:

1. If the error is 0; the output stays fixed at a value to what it was. When the error went to 0.
2. If the error is not 0, the output will begin to increase or decrease at the rate of  $K_i \%$ /sec for every one one percent of error.



### Applications:

The integral mode eliminates the offset.

## 2.8 Derivative control mode

In Derivative control mode, the controller output depends on the rate of change of error. It is also known as rate controller or anticipatory response. Derivative control mode cannot be used alone because when the error is 0 or constant, the controller has no output. The Derivative control mode is given by the following equation:

$$p = K_D \frac{d\epsilon_p}{dt}$$

Where,

$K_D$  = derivative gain constant (%-s/%)

$\frac{d\epsilon_p}{dt}$  = rate of change of error (%/s)

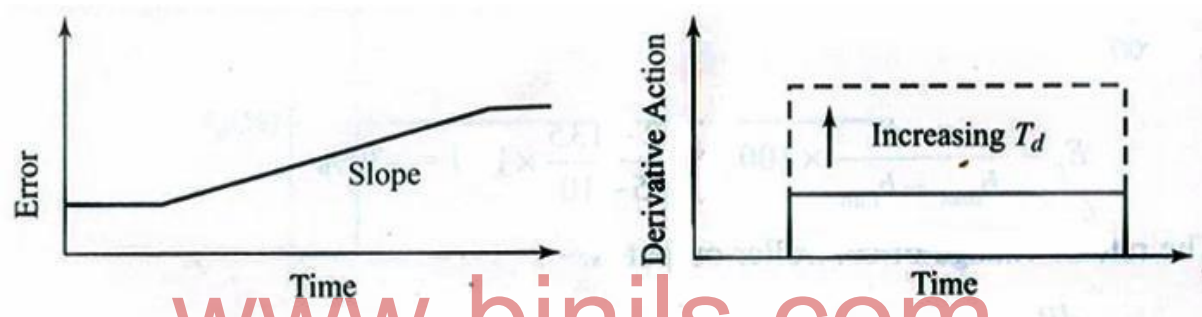

Figure 2.16 Response of derivative control mode to terminated ramp input

Derivative controller anticipates what the error will be in the immediate future and applies action which is proportional to the current change in the error. Disadvantage of this mode is that for a noisy response with almost a zero error it can compute large derivative and thus yield large action although it is not needed. The derivative gain constant  $K_D$  is called the rate of derivative time. It is expressed in minutes.

Derivative time is defined as the time interval by which the rate action leads, advances the effect the proportional control action. The characteristics of the derivative mode are as follows:

1. If the error is 0, the mode provides no output.
2. If the error is constant in time, the mode provides no output.
3. If the error is changing in time, the mode contributes an output of  $K_D\%$  for every 1%/sec rate of change of error.
4. For direct action, a positive rate of change of error produces a Positive derivative mode output.

## 2.9 Composite control modes

The basic control modes can be combined to get the added advantages of each mode there by eliminating their limitations. The combinations of control modes are

1. Proportional-integral modes (PI)
2. Proportional-derivative modes (PD)
3. Proportional-derivative-integral modes (PID)

## 2.10 Proportional-integral modes

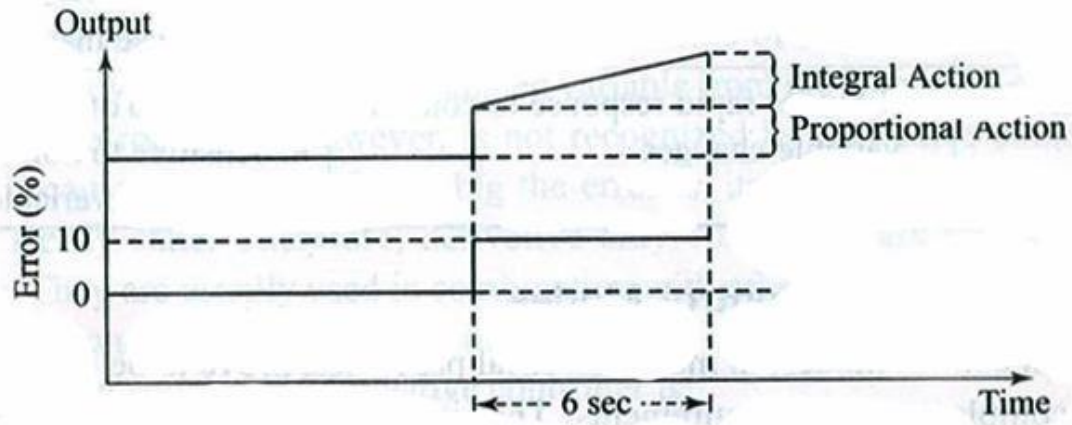

Figure 2.17 Response of PI control mode to step input

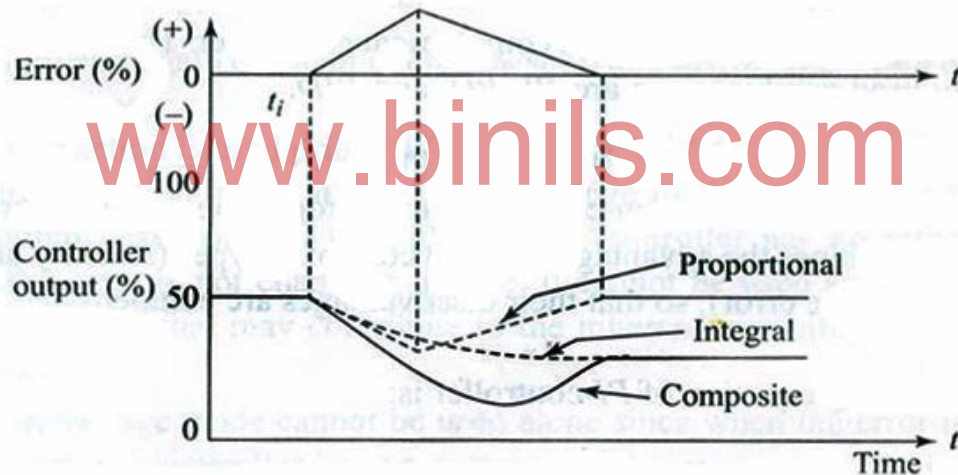

Figure 2.18 Proportional-integral action (reverse action)

Proportional-integral modes are the combination of the proportional modes and the integral modes results in proportional-integral modes. The advantages of both control actions can be obtained from this mode. This is also called as proportional plus reset action controller. The equation for proportional-integral mode is

$$p = K_p e_p + K_p K_I \int_0^t e_p dt + p_{t(0)}$$

Where,

$p_{t(0)}$  = integral term value at  $t=0$ .



### **Advantages:**

The proportional controller gives one-to-one correspondence and the integral modes eliminates offset. The gain  $K_c$  and  $K_I$  can be independently adjusted.

When a load change occurs, the proportional controller gives an offset, then the integral function provides the required new controller output there by, the error reaches 0. The characteristics of PI mode:

1. When the error is 0, the controller output is fixed at the value that the integral term had when the error tends to 0 ( $p_{r(0)}$ ).
2. If the error is not 0, the proportional term gives a correction and the integral term increases or decreases the initial  $p_{r(0)}$  value depending on the sign of the error and the direct or reverse action. The integral term cannot become negative. It will saturate at 0, if the action tends to net negative value.

### **Reset rate/repeats per minute:**

The integral action adjustment is the integral time  $T_I = \frac{1}{K_I}$ . For a step change of deviation  $e$ , the integral time or reset time is the time required to add an increment of response equal to the original step change of the proportional action as shown in figure 2.17. Reset rate is defined as the number of times per minute that the proportional part of the response is duplicated. Reset rate is called repeats per minute and is the inverse of integral term  $K_I$ .

### **Applications:**

PI mode can be used in systems with frequent or large load changes.

### **Disadvantages:**

The process must have slow changes in load to prevent from oscillations induced by the integral overshoot. During start-up of a batch process, the integral action causes an overshoot of the error. When error cannot be eliminated quickly and given enough time. This mode produces larger and larger values for integral time which in term keeps increasing the control action until it is saturated; this condition is called integral windup. This occurs during change over operations and shutdowns.

## **2.11 Proportional-derivative control modes (PD)**

The combination of proportional control mode and the derivative control mode is called as Proportional-derivative control mode. Equation for proportional-derivative control mode is

$$p = K_p e_p + K_p K_D \frac{de_p}{dt} + p_0$$

This controller can handle fast process load changes. It cannot eliminate the offset of proportional controller.

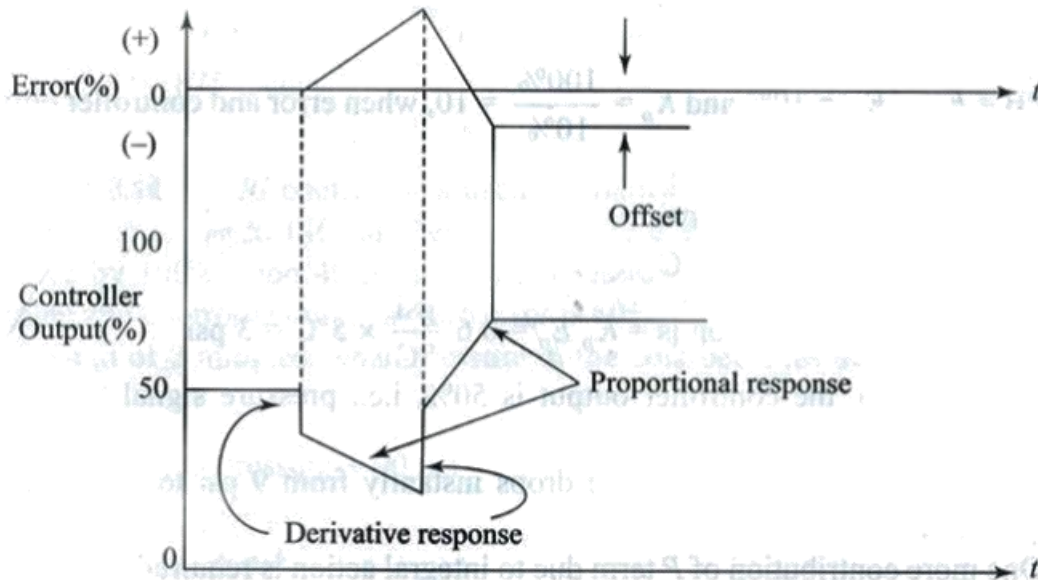
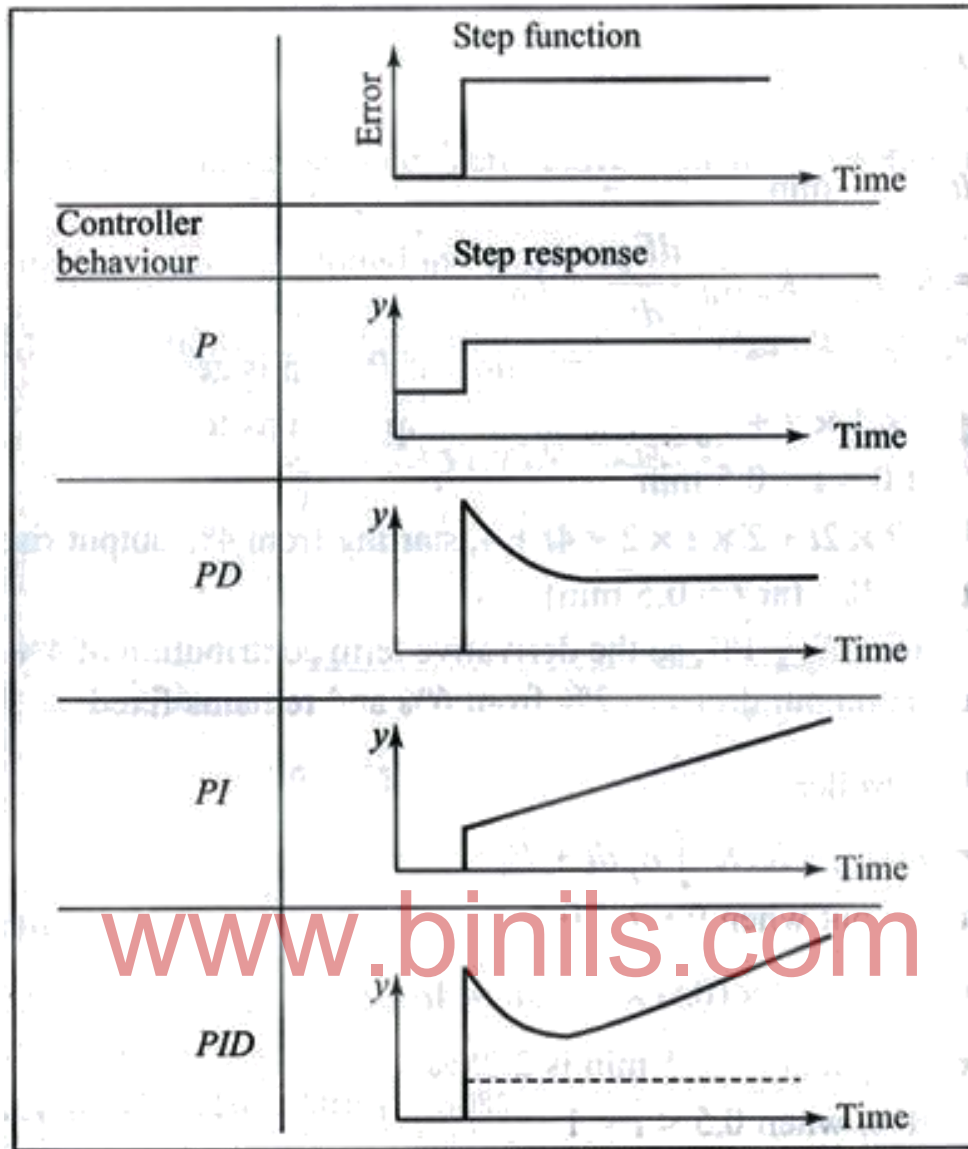

Figure 2.19 Error vs time and PD controller output vs, time

### 2.12 Proportional-integral-derivative control modes (PID)

The PID controller is called as 3mode controller. It is commonly known as proportional+ reset+ rate controller. It's most powerful and complex controller mode action. This equation of PID mode is

$$p = K_p e_p + K_p K_I \int_0^t e_p dt + K_p K_D \frac{de_p}{dt} + p_{t(0)}$$



**Figure 2.20 Response of different controllers for step input**

This mode eliminates the offset of the proportional mode but still provides fast response. The three adjustment parameters are proportional gain, integral time and derivative time. PID controller can give better control than 1 or 2 mode controllers. In practice, it's difficult to select the tuning parameters for PID controller. The derivative mode in PID controller is used to compensate for hardware lacks in the process. PID controllers are used in the industries to control slow variables such as temperature, pH and analytical variables. The figure 2.20 shows transient response of continuous controllers for step input.

The input signal (a step change).

Output variable (manipulated variable).

Proportional control action:

Final control element is operated by an amount proportional to the deviation.

Proportional+reset action controller:

The final control element first operated by an amount proportional to the deviation and then by an amount depending on its period.

Proportional+rate control action:

The final control element is first operated by an amount depending on the rate of change of controlled variable and then as with proportional controller.

Proportional+reset+rate action controller:

The final control element is first operated by an amount depending on the rate of change of the controlled variable and then with the proportional+reset action control. By properly tuning the controllers we can get good controller response.

### 2.13 Selection of controller

- a) Proportional controllers are used for processes having,
  - i) Small load changes.
  - i) Acceptable offset levels.
  - ii) Narrow proportional band (PB) reduces the offset.
- b) Integral control is used for processes having:
  - i) Offset must be zero.
  - ii) To remove long and tedious deviations.
- c) Derivative control is used in processes having,
  - i) Very large lag.
  - ii) To reduce deviations during changes in the plant. For a) and b) processes P+ I mode is used.

For a) and c) processes P+D mode is used. For a),b),c) processes P+I+D mode is selected.

**Table 2.1 Advantages and Disadvantages of Controllers**

S.N	Control mode	Advantages	Disadvantages
1.	On-Off Controller	Simple, low cost.	The controlled variable will cycle above and below the set point.
2.	Proportional Controller	Steady control.	Presence of offset, narrow proportional band will lead to on-off control action.
3.	Integral Controller	Removes offset.	Recovery time will be longer with more oscillations, slow response for rapid changes.
4.	Derivative Controller	Anticipate controller output.	Recovery time

			will be longer with more oscillations, slow response for rapid changes.
5.	Proportional+ Integral Controller	Removes offset.	Recovery time is longer than P control.
6.	Proportional+ Derivative Controller	Recovery time is lesser than P control, good control for processes having large lag, stable control, narrow proportional band can be used to reduce offset.	Presence of offset.
7.	Proportional+ Integral+Derivative Controller	No offset, short recovery time, best control.	3 parameters must be tuned.

### 2.14 Electronic Controller

High speed of response, small size, circuits can be modified based on our requirements, easily connected with computers, operational amplifiers are used to construct P,D,I,PI,PD,PID electronic controllers, easy to install, identification of errors are easier, the dynamic response of electronic controllers are good than hydraulic and pneumatic controllers, process variables can be monitored continuously for a long time and can be controlled, the standard electrical range of signals used in industries are 4-20mA/0-10V.

[www.binils.com](http://www.binils.com)

### 2.15 Error detector

Error detectors or comparators are used to compare set point with measured variable and used to give error value. The comparator acts as a bridge between analog input signals and digital two-position output. Op Amps LM318, LM311 are comparators.

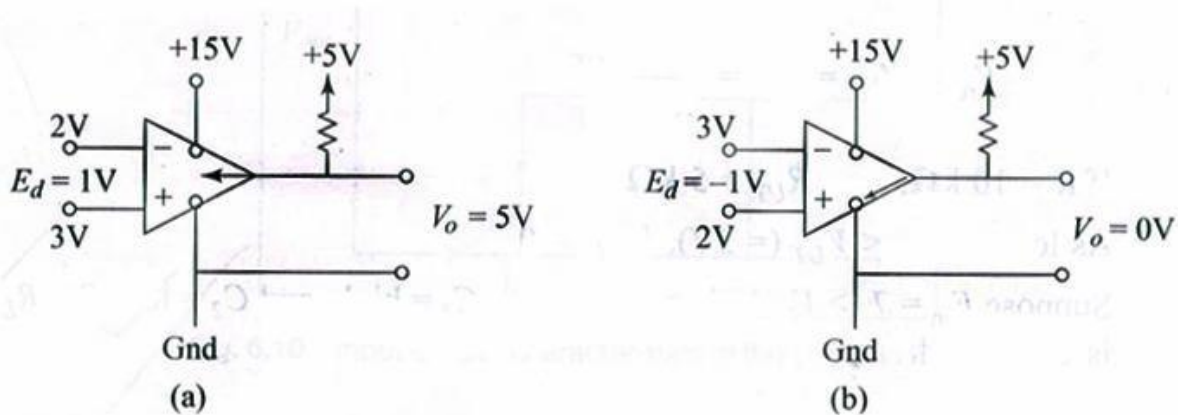

Figure 2.21 Internal connection and output LM339 for  
 (a) positive differential input                      (b) negative differential

Op Amps LM311, LM399 are comparators without feedback. Slew rate of IC741 is  $0.5V/\mu s$ . For AC, input supply Op Amp must have high slew rate. Slew rate is defined as the high speed in rate of change of output with respective Op Amp's input signal frequency. The slew rate LM311 Op Amp is  $70V/\mu s$ . LM311 has one precision comparator in it. Its output is upto 50 volts/50mA. The figure 2.21 shows an error detector using LM339. When  $E_d$  is negative, the switch is connected to ground and output is 0V. When  $E_d$  is positive, the switch is open and the output is 5V.

## 2.16 Electronic On-Off Controller with neutral zone using LM339

Discontinuous controllers are also known as switching controllers.

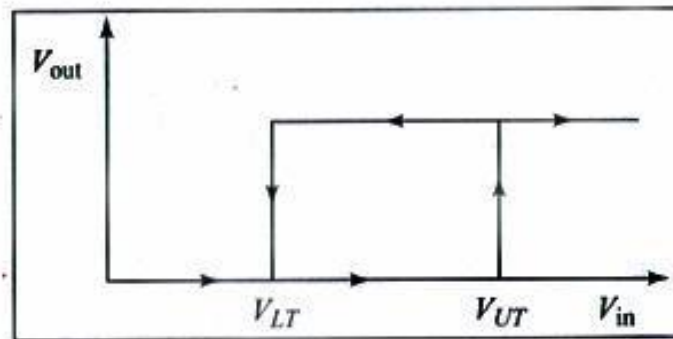

Figure 2.22 Input -output characteristics of the circuit.

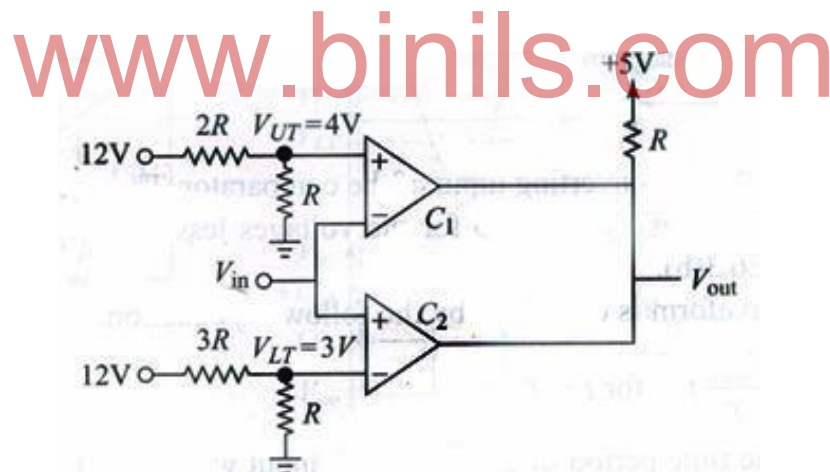

Figure 2.23 Window comparator realization using LM339

LM339 is a comparator IC. There are 4 comparators in one IC. In the figure 2.23, an on-off controller with neutral zone is constructed using LM339. It's also known as widow comparator.

$V_{UT}$  = upper voltage limit, comparator1 (C1).

$V_{LT}$  = lower voltage limit, comparator2 (C2).

Let

$V_{UT} = 4V$ ,  $V_{LT} = 3V$ :

If  $V_{in} = 5v$ , then C1; low C2; high and  $V_{out}$ ; low.

If  $V_{in} = 2V$ , then C1; high C2; low and  $V_{out}$ ; low.

If  $V_{in} = 3.5V$ , then C1; high C2; high and  $V_{out}$ ; high.

If  $V_{in}$  is in between  $V_{LT}$  (=3V) and  $V_{UT}$  (=4V), then  $V_{out}$  is high.

If  $V_{in}$  less than  $V_{LT}$ ,  $V_{out}$  is 0 and if  $V_{in}$  greater than  $V_{UT}$ , the output is high.

$$V_{out} = 5V: (V_{LT} < V_{in} < V_{UT})$$

$$V_{out} = 0V: (V_{LT} > V_{in})$$

$$V_{out} = 0V: (V_{UT} < V_{in})$$

## 2.17 Electronic proportional controller

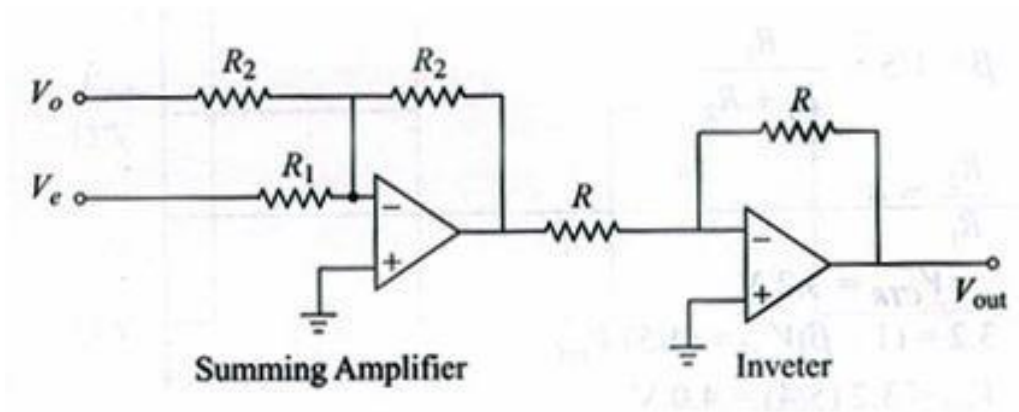

Figure 2.24 Electronic proportional controller

Using negative feedback in Op Amps P,I,D,PI,PD,PID controllers are constructed. The output of proportional controller is given by:

$$P = K_p E_p + F_o$$

Where,

$F_o$  = controller output (0-100%),

$K_p$  = Proportional gain

$E_p$  = error in %

$F_o$  = controller output when error is 0.

If we change the controller output and error as voltage, the equation becomes

$$V_{out} = K_p V_e + V_o$$

The above equation can be realized using a summing amplifier. This figure 2.24 shows an electronic proportional controller using Op Amp.

$K_p = \left(\frac{R_2}{R_1}\right)$ , proportional gain.

$V_e$  = error voltage.

Input error signal of Op Amp is scaled for full range of error signal. Output signal is scaled for 0-100% or 4-20mA controller signal. Proportional gain is adjusted using  $\left(\frac{R_2}{R_1}\right)$

## 2.18 Electronic-Integral Controller

Integral controller output is given by



$$P = K_I \int_0^t E_p dt + P_0$$

where,

P = Controller output,

P<sub>0</sub> = Controller output when error is 0,

E<sub>p</sub> = Error in %,

K<sub>I</sub> = Integral time constant.

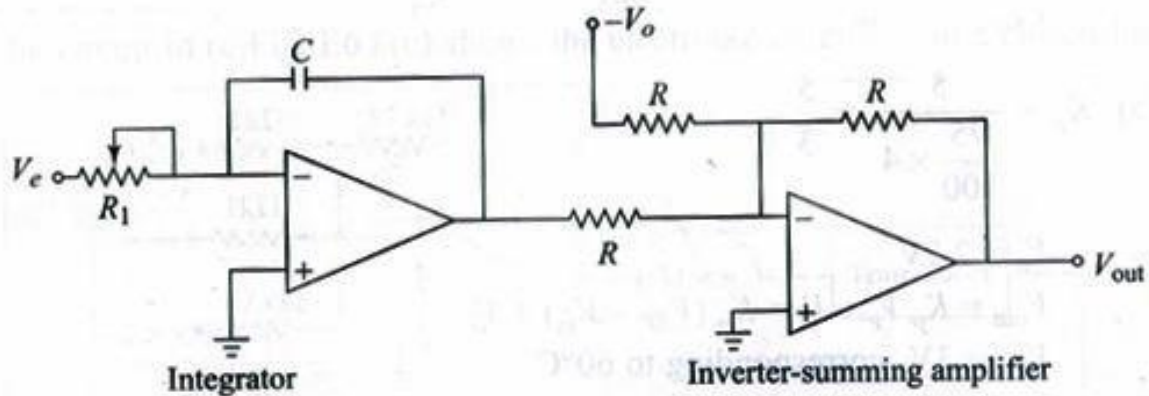

Figure 2.25 Circuit diagram of an electronic integral controller

In electronic integral controller, input error and output are converted into voltage. The equation of electronic-integral controller is

$$V_{out} = K_I \int V_e dt + V_0$$

where,

$$K_I = \frac{1}{R_1 C}; \text{ integration constant.}$$

V<sub>e</sub> = error voltage,

V<sub>0</sub> = initial output voltage.

The output of integrator in the first stage is  $K_I \int V_e dt$ , if we change the value of R and C, we can get required integration time. Integration time constant indicates the ratio of increase in controller output when error is constant. If the value of K<sub>I</sub> is very large, output will increase above setpoint and results in overshoot. The output response will have cycling / oscillations.



## 2.19 Electronic derivative controllers:

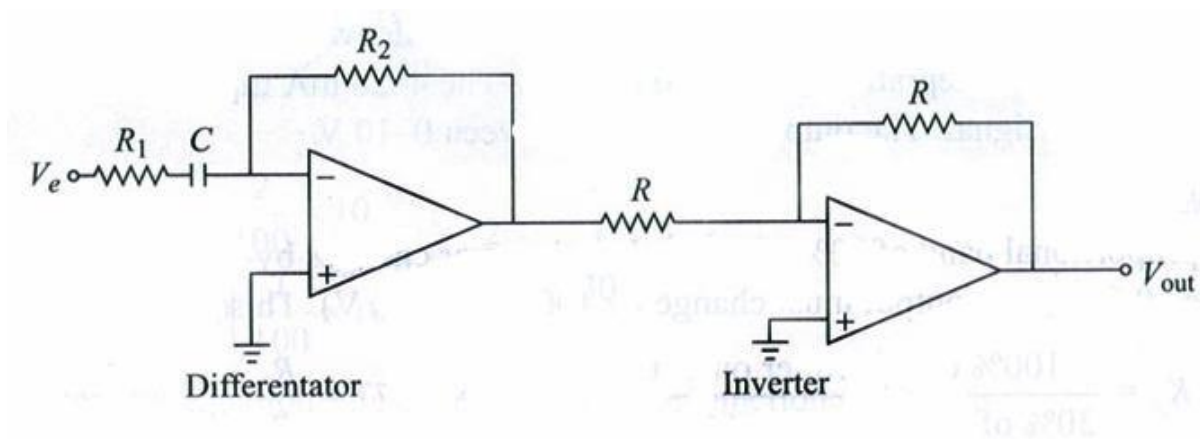

Figure 2.26 Circuit diagram electronic derivative controller

The equation for derivative controller is

$$p(t) = K_D \frac{dE_p}{dt} + P_0$$

where,

$E_p$  = Error in percentage

P = Controller output

$P_0$  = Controller output when error is 0

$K_{D,1}$  = Derivative time constant (s) ( $K_{D,1} = R_2 C$ ).

In electronic derivative controllers, the input error and controller output are mentioned in voltages. The equation for electronic derivative controller is

$$V_{out} = K_D \frac{dV_e}{dt} + V_o$$

Where,

$V_e$  = error voltage,

$V_o$  = output voltage when error is 0.

## 2.20 Electronic PI controller

When proportional and integral circuits are connected, we can get proportional integral mode control action. The equation for PI controller is

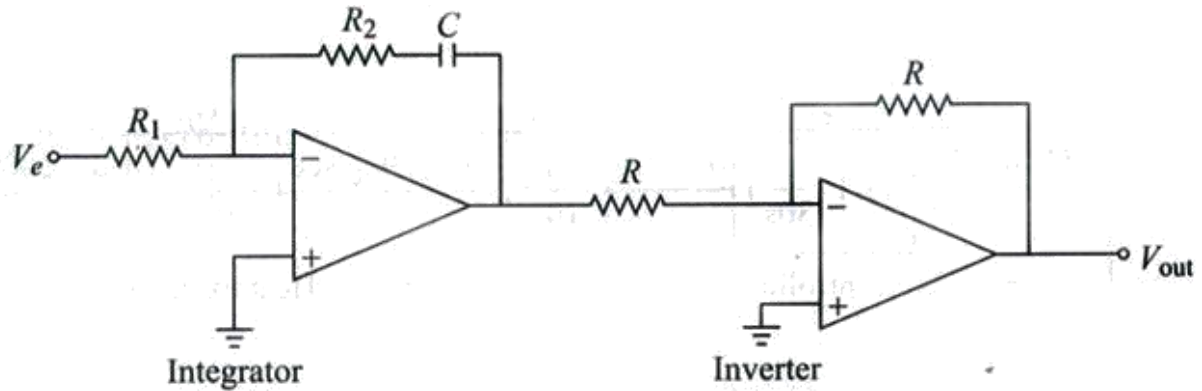

**Figure 2.27 Circuit for electronic PI controller**

$$V_{out} = \left(\frac{R_2}{R_1}\right)V_s + \frac{1}{R_1 C} \int V_s dt$$

To change the proportional band, the value of  $K_p$  is modified  $K_p = \left(\frac{R_2}{R_1}\right)$ . To change integration gain, the value of  $K_i = \left(\frac{1}{R_1 C}\right)$  is modified. The figure 2.27 shows the circuit of PI controller.

### 2.21 Electronic PD controller

The figure 2.28 shows the circuit of Electronic PD controller.

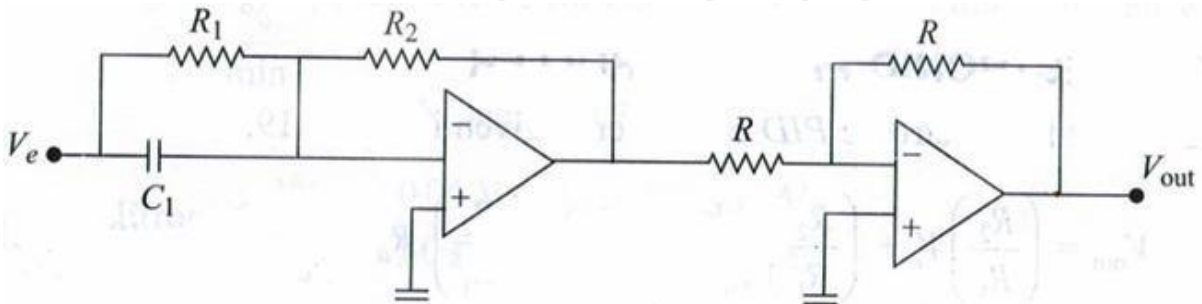

**Figure 2.28 Circuit realization of PD controller**

$$V_{out} = \left(\frac{R_2}{R_1}\right)V_s + \left(\frac{R_2}{R_1}\right)R_1 C_1 \frac{dV_s}{dt} + V_{out}(0)$$

## 2.22 Electronic PID controller

The figure 2.29 shows the circuit of Electronic PID controller.

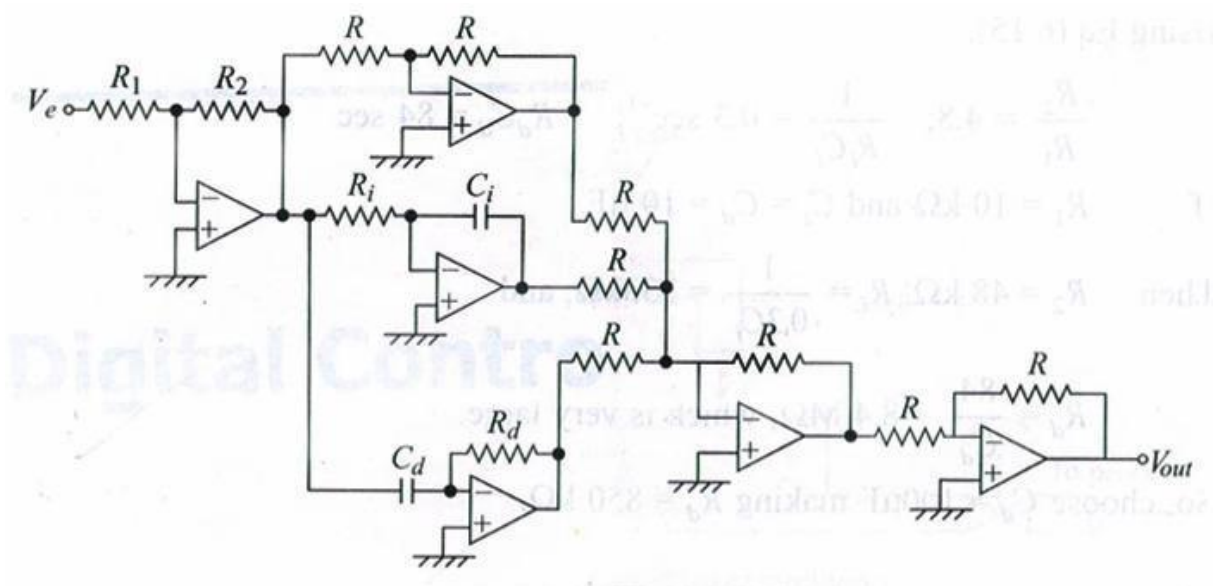

Figure 2.29 Circuit of electronic PID controller

$$V_{out} = \left(\frac{R_2}{R_1}\right) V_e + \left(\frac{R_2}{R_1}\right) \frac{1}{R_1 C_i} \int V_e dt + \left(\frac{R_2}{R_1}\right) R_d C_d \frac{dV_e}{dt} + V_{out}(0)$$

www.binils.com

## 2.23 Pneumatic controller

Gases are used as mediums to transmit signals and power. Gases can be compressed; they fill in the volume of the container. Pneumatic systems are those which use gases as their medium. Pneumatic systems are reliable. Pneumatic systems are used in industrial process control. The pipelines used for air transmission must be clean and free from dust particles for efficient performance. In pneumatic systems, response is slow. The measuring sensors will give electrical output only. I-P (current to pressure) converters are used to convert electrical to pneumatic signals. Pneumatic systems are simple and easy to maintain.

## 2.24 Flapper and nozzle

Flapper-nozzle is an important element in pneumatic systems. The power supply to the pneumatic system is air at constant pressure. The figure 2.30 shows a construction of flapper-nozzle. It consists of nozzle a small hole, and flapper a thin metallic strip. The lower end of the flapper is fixed. Its upper end can be moved to and fro.

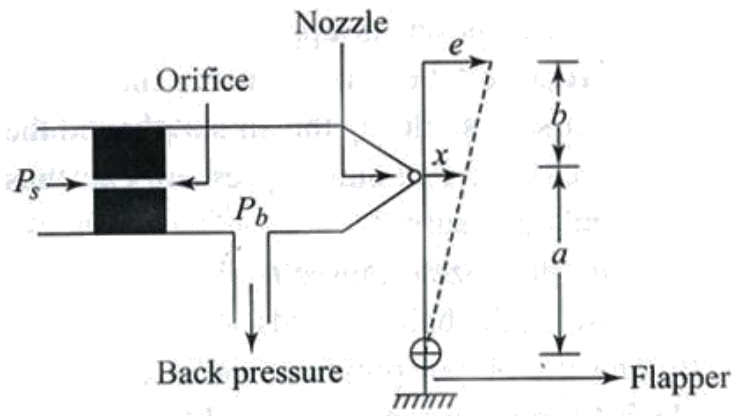

Figure 2.30 Flapper nozzle

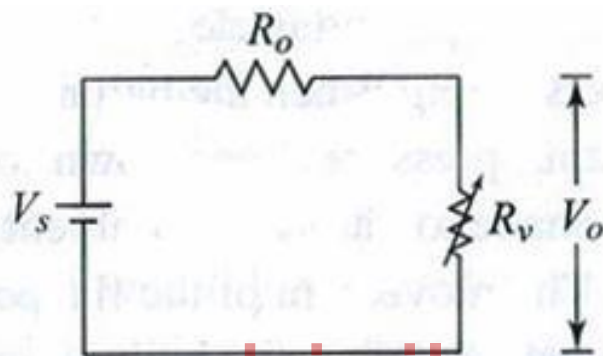

Figure 2.31 Electrical equivalent of basic flapper nozzle system

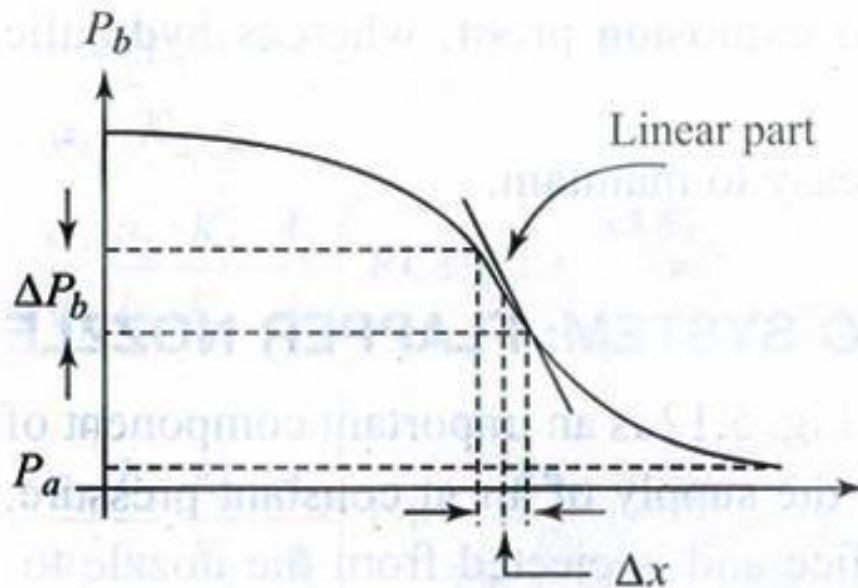

Figure 2.32 Curve relating the nozzle back pressure and nozzle flapper distance

Pressurized air  $P_s$  is supplied through an Orifice. The velocity of out coming air is high. This high velocity air is moved towards the flapper. Flapper is designed to close the nozzle's hole. So, the air cannot pass through the nozzle and results as back

pressure  $P_b$ . If we control the distance  $x$  between nozzle and flapper, it's possible to control the back pressure i.e., if the nozzle is completely closed, air can't pass through the nozzle. The back pressure will be equal to the supply pressure. If the distance between flapper and nozzle is increased, there is no barrier for air to pass; the back pressure will be low. Thus, small changes in flapper positions will give large changes in back pressure. Figure 2.32 shows the relationship between back pressure  $P_b$ , and distance between flapper and nozzle. If the flapper moves away from the nozzle, the output of the controller is reduced. Air supply is continuously given to the pneumatic system. Air is continuously used in the system except when the nozzle is closed, the flapper must not be moved because of the leakage air. So the size of the nozzle must be small. The diameter of the Orifice must be less than the diameter of the nozzle. In order to, provide the necessary pressure drop. If the size of the Orifice is very small, there is a possibility of block due to dust in the air supply. Instrument air supply given to the pneumatic system is 20psi. Flapper and nozzle is very sensitive. The back pressure is 1psi for 0.0001 inch of flapper movement.

## 2.24 Pneumatic relay (power booster)

Pneumatic amplifiers are also known as pneumatic relays. Flapper and nozzle systems are linear only when the displacement of flapper is very small. During linear operations, there will be very small change in output pressure. So there is a need for pneumatic amplifiers. Pneumatic relays are used along with flapper-nozzle. Pneumatic relays consist of a bellow and a ball. The ball is placed below the bellow. The ball can able to move up and down. If the ball is in its upper seat, it blocks the air to atmosphere. All the supplied air  $P_s$  will come out as output pressure  $P$ . If the ball is at its lower seat, the supply air  $P_s$  is blocked. The output pressure  $P$  is reduced to atmospheric pressure. Thus, the output pressure  $P$  can be varied from atmospheric pressure to supply pressure. If the flapper moves away from the nozzle, back pressure  $P_b$  will be less, bellow will contract, the ball connected to the bellow will move up to the upper seat. This action closes atmospheric hole, the output pressure will increase. If the flapper moves towards the nozzle-back pressure increases, the bellow starts expanding, the ball connected to the bellow closes the output pressure path. So, the output pressure reduces towards atmospheric pressure. The pneumatic relay boosts up the output pressure of the flapper nozzle. All the time except the ball at its upper seat, the air will bleed from the pneumatic relay. So, it is known as bleed relay. The basic component of pneumatic system is flapper-nozzle. In order to amplify the output pressure, pneumatic relays are used along with flapper and nozzle. Pneumatic systems are safe and give less power. Air leakage is common, has high operating temperature range.

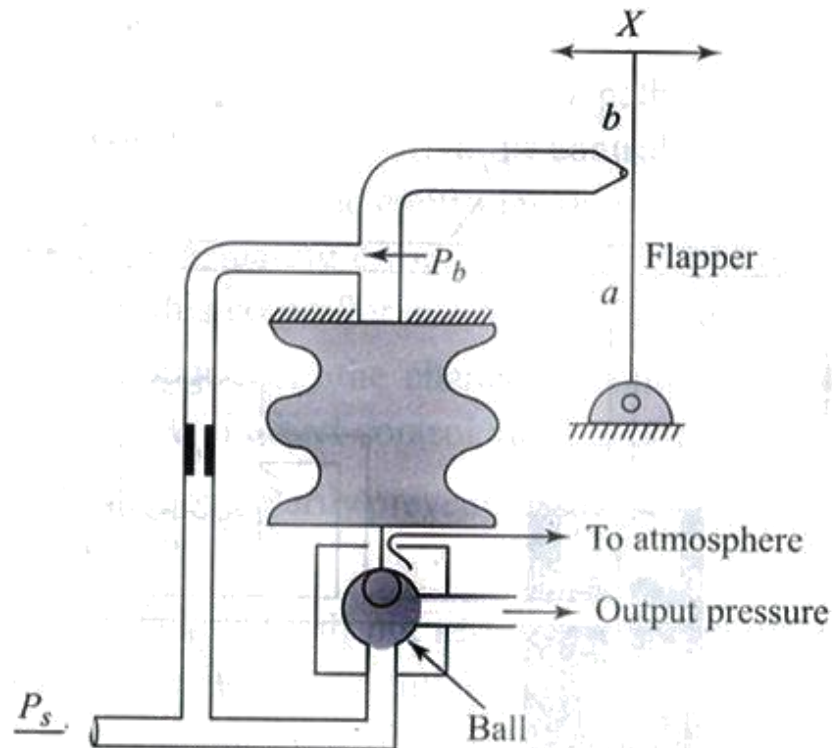

Figure 2.33 Pneumatic relay

REVIEW QUESTIONS

www.binils.com

PART A

1. What is controller? (2)
2. What are the types of controllers?
3. What do you mean by controller mode?
4. Define proportional band.
5. Define proportional gain.
6. What is integral time?
7. Define differential time.
8. What is called an offset in proportional controller?

PART B

1. Define reverse and direct actions of the controller. (3)
2. Define self regulation.
3. What is offset? How is it eliminated?
4. Differentiate between discontinuous and continuous controller modes.
5. When on-off controller is suitable?
6. Give applications of on-off control.
7. What are the different control modes in process control?
8. What is proportional mode?
9. Give the controller equation of proportional mode.

10. Define differential gap. How is it related to the performance of final control element?
11. Give the characteristics and applications of two position control mode.
12. Name the three different continuous control modes.
13. What are called composite control mode? Name at least three such composite modes.

**PART C**

1. Sketch the characteristics of on-off controller and explain. (10)
2. Explain the special features for PI controller.
3. Give the characteristics of PI controller.
4. Give the salient features and applications of PD controller.
5. Give the salient features and applications of PID controller.
6. What are the advantages of electronic controllers.

[www.binils.com](http://www.binils.com)



## Unit III - TUNING OF CONTROLLERS

Concept of tuning – criteria for controller tuning – quarter Decay ratio, IAE, ISE, ITAE – methods of tuning – open loop response method – process reaction curve – closed loop response method – ultimate cycle method - damped oscillation method.

---

### 3. TUNING :

The process of adjusting parameters like  $K_P$ ,  $K_I$ ,  $K_D$  to obtain an optimum control action is called Tuning.

#### 3.1 CONCEPT OF TUNING :

After Selecting the type of feedback controller , one has to decide values for its adjusted parameters like  $K_P$ ,  $K_I$ ,  $K_D$  . This Process of deciding values for adjusted parameters ( Tuning Parameters ) is called Tuning.

The Tuning of process control loop consists of finding the optimum settings of controller gains for good control.

#### 3.2 CRITERIA FOR CONTROLLER TUNING:

The three general approaches for tuning a controller are ,

1. Using simple criteria such as the one – quarter decay ratio (  $\frac{1}{4}$  decay ratio ) minimum settling time , minimum largest error and so on.
2. Using time integral performance criteria such as ISE,IAE or ITAE.
3. Using semi empirical rules which have been proven in practice.

There are many methods for determination of the optimum mode gains, depending on the nature and complexity of the process. Here three common tuning methods are considered to give a basic idea of how optimum adjustments are found.

#### 3.3 QUARTER DECAY RATIO :

The Decay Ratio is the ratio of the amounts above the ultimate value of two successive Peaks. If the ratio  $C/A$  is equal to  $\frac{1}{4}$  then the ratio is quarter

Decay Ratio.

$$\text{Decay Ratio} , \frac{C}{A} = \frac{1}{4}$$

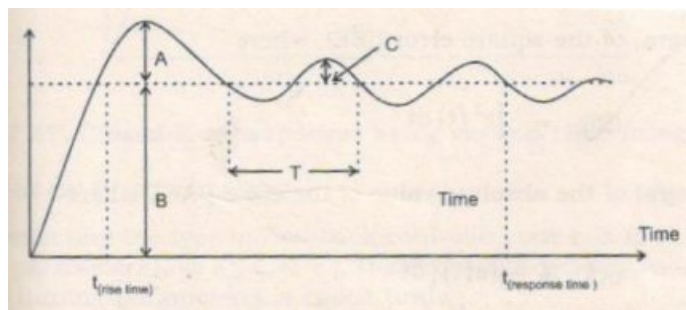

### Fig 3.1 Quarter Decay Ratio

#### 3.4 TIME INTEGRAL PERFORMANCE CRITERIA :

Simple performance criteria use only isolated characteristics of the dynamic response , like decay ratio, settling Time.

Time – Integral performance criteria are based on the entire response of the process. The most important are,

1. Integral of the Square error ( ISE ) , Where

$$ISE = \int_0^{\infty} e^2 ( t ) dt$$

2. Integral of the Absolute value of the error ( IAE ) , Where

$$IAE = \int_0^{\infty} | e ( t ) | dt$$

3. Integral of the Time – weighted absolute error ( ITAE ) ,

$$\text{Where } ITAE = \int_0^{\infty} t | e ( t ) | dt$$

The types of the controller and the values of its adjusted parameters may be selected in such a way as to minimize the ISE,IAE, or ITAE of the system's Response.

1. Different criteria lead to different controller designs.
2. For the same time Integral criterion , different input changes lead to different designs.

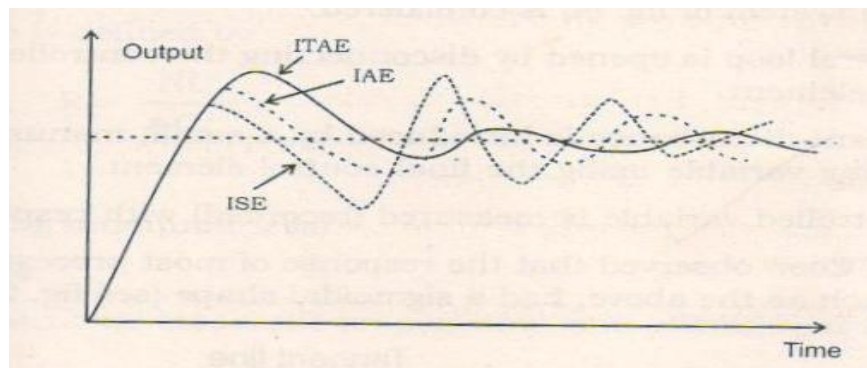
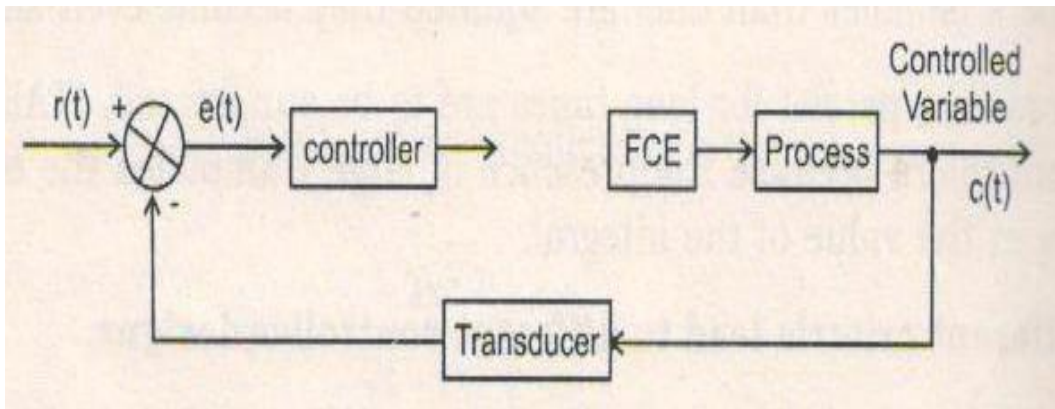

Fig 3.2 Various Time Integral Criteria

#### 3.5 METHODS OF TUNING :

1. Process Reaction Curve Method
2. Ziegler – Nichols Method
3. Damped Oscillation Method
4. Frequency Response Method

### 3.5.1 OPEN LOOP RESPONSE METHOD : ( PROCESS REACTION CURVE METHOD )



**Fig3.3 Process Reaction Curve Method**

The control system is considered ,

1. The Control loop is opened by disconnecting the controller from the final control Element.
2. A Transient disturbance is introduced by a small , manual change of the controlling Variable using the final control Element.
3. The controlled variable is measured ( recorded ) with respect to Time.

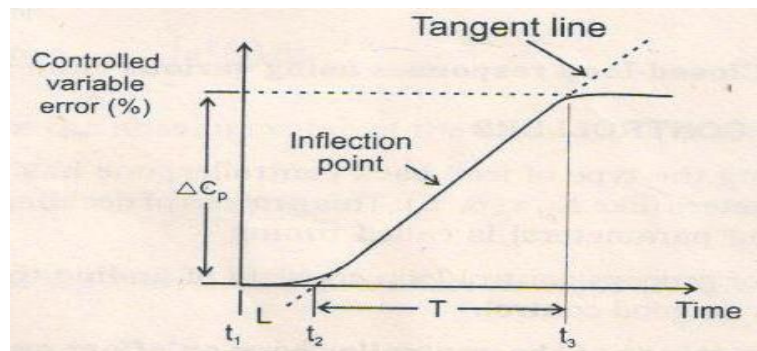

**Fig3.4 Process Reaction Curve**

The open loop controller response , where the input change ( disturbance) is applied at  $t_1$ .Controlled variable and error are taken in the y - axis and expressed in %.

A Tangent line is drawn at the inflection point of the curve. The inflection point is defined as that point on the curve where the slops stops increasing and begins to decrease.

The point at which the tangent line crosses the x- axis is noted as  $t_2$ . The time between  $t_1$  and  $t_2$  is denoted as  $L$ , where

$$L = \text{lag time in minutes}$$

From  $t_2$  to  $t_3$ , we get  $T$ , the process reaction time. The reaction rate  $N$  is given by

$$N = \frac{\Delta C_p}{T}$$

Where,

$$N = \text{Reaction rate in \% / min}$$

$$\Delta C_p = \text{Variable change in \%}$$

$$T = \text{Process reaction time in minutes}$$

The log ratio is defined by

$$R = \frac{M}{\Delta C_p}$$

Where ,

$$R = \text{log ratio ( unit less )}$$

**Proportional Mode :**

For the proportional mode , the proportional gain setting  $K_p$  is found from

$$K_p = \frac{\Delta P}{NL}$$

**Proportional - Integral Mode :**

The appropriate settings for proportional gain and integration time are

$$K_p = C_1 C_2 \frac{\Delta P}{NL}$$

$$T_i = \frac{L}{K_i} = 3.33L$$

**Proportional - Integral Derivative Mode :**

The appropriate proportional gain , integration time and derivative time

$$K_p = 1.2 \frac{\Delta P}{NL}$$

$$T_i = 2L$$

$$T_D = 0.5 L$$

This method can be used only for systems with self regulation .

### 3.5.2 ZIEGLER NICHOLS METHOD :

Ziegler and Nichols developed a method of controller tuning associated with their name. This technique is also called as the Ultimate Cycle Method. This method is based on adjusting a closed loop until steady oscillations occur.

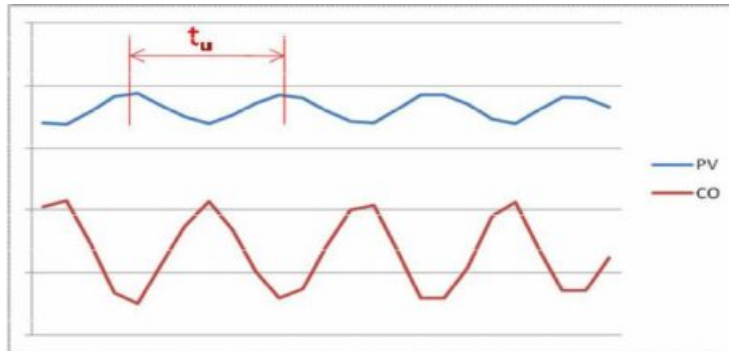

**Fig 3.5 Ziegler Nichols method curve**

#### **Procedure : ( Steps to be followed )**

1. Reduce any integral and derivative actions to their minimum effect.
2. Gradually begin to increase the proportional gain while providing periodic small disturbances to the process.
3. Note the critical gain ,  $K_c$ , at which the dynamic variable just begins to exhibit steady cycling ( Oscillations about the set point )
4. Note the critical period  $T_c$ , of these oscillations measured in minutes.

This method can be used for systems without Self – Regulation.

#### **Proportional Mode :**

For this mode , the proportional gain is

$$K_p = 0.5K_c$$

When the quarter – amplitude criterion is applied , the gain is simply adjusted until the dynamic response pattern to a step change in set point obeys the quarter – amplitude response criterion. This also results in some gain less than  $K_c$ .

#### **Proportional – Integral Mode :**

The settings fir this mode are determined from

$$K_p = 0.45 K_c$$

$$T_i = \frac{T_c}{1.2}$$

When the quarter – amplitude criterion is applied , the correction is

$$T_i = T_c$$

And the gain is adjusted to obtain the quarter amplitude response.

#### **PID Mode :**

The proportional gain, integral time and derivative time are determined from

$$K_p = 0.6 K_C$$

$$T_i = \frac{T_c}{2.0}$$

$$T_d = \frac{T_c}{8}$$

When quarter – amplitude criterion is desired, we get

$$T_i = \frac{T_c}{1.5}$$

$$T_d = \frac{T_c}{6}$$

And the proportional gain is adjusted for the quarter – amplitude response.

#### **3.5.3 Damped Oscillations Method :**

1. In this method, proportional gain is only adjusted, until a response curve with a decay ratio  $\frac{1}{4}$  is obtained.
2. It is necessary to note P value.
3. With this P value, integrating and derivative modes are set,

$$T_i = \frac{T_c}{1.5}$$

$$T_d = \frac{T_c}{6.0}$$

---

#### **REVIEW QUESTION :**

##### **PART - A ( 2 marks )**

1. Expand ITAE.
2. Mention the closed loop response method of controller tuning used in process control.
3. What are the tuning Criteria.
4. Write down the methods of controller Tuning.
5. What is the Expansion of IAE.
6. Name any one method of closed loop tuning of controller.

7. What is Simple Criteria.

PART – B ( 3 marks )

1. Give the concept of Tuning.
2. What is the need for Tuning? ( or) Why we are Tuning.
3. What is the time integral Performance Criteria.
4. Define Quarter Decay Ratio.
5. What is Damped Oscillation Method.
6. What is the shape of the response that occur in Process Reaction Method.

**PART – C (10 marks )**

1. Explain the operation of Open loop response method of Controller Tuning.
2. Brief about Damped Oscillation Method of Controller Tuning.
3. Explain the closed loop Response method of controller Tuning.
4. Compare Ultimate Cycle Method & Damped Oscillation Method.
5. Explain the Quarter Decay Ratio methods of Tuning.

[www.binils.com](http://www.binils.com)



## UNIT IV - FINAL CONTROL ELEMENTS

Signal converters – P to I converter, I to P converter – actuator – electrical, pneumatic, hydraulic–control valve – characteristics - quick opening, linear, equal percentage–pneumatic valve – solenoid valve –split range control valve – single seat and double seat plug – electric motor actuated control valve – control valve sizing – CV rating – selection of a control valve – effect of cavitation and flashing on control valve performance.

---

### 4 . INTRODUCTION :

Final control Elements involve in the steps necessary to convert signal into proportional action on the itself. The final control elements is the mechanism , which translate the signal from manipulated variable to the process variable . The position of the final control element is shown in the figure.

#### 4.1 BLOCK DIAGRAM:

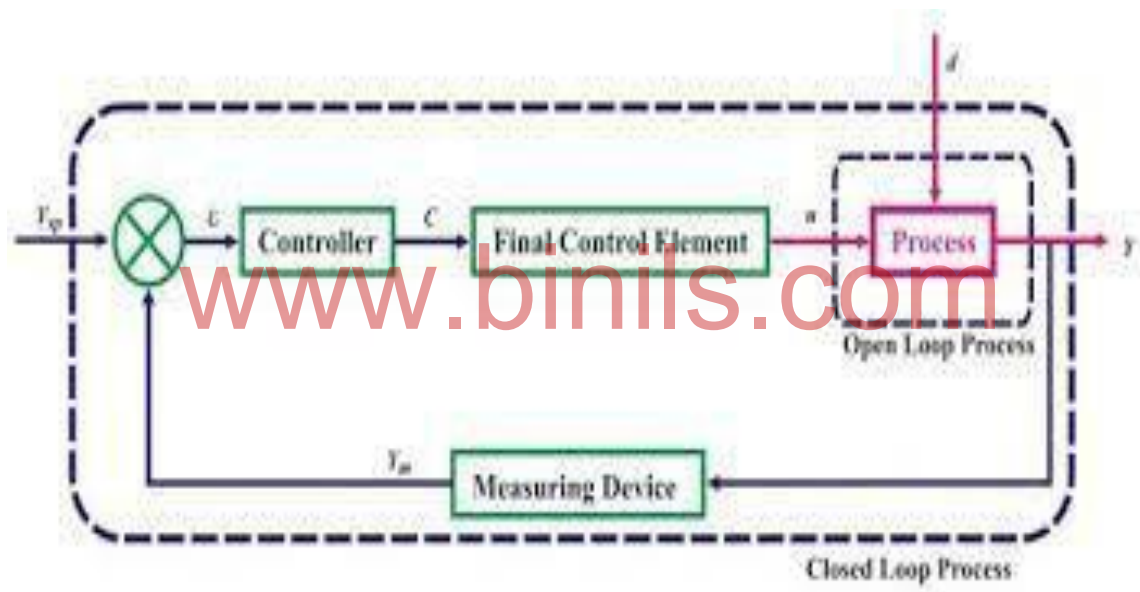

Fig 4.1 Block diagram of Final control Elements

#### 4.2 SIGNAL CONVERTERS :

The previous Stage of the final control element is controller. Different types of controller are used in process control Pneumatic , Electronic , Hydraulic Set. If the output of the electronic controller is given to the final control element. The final control element use in the process is Pneumatic one.

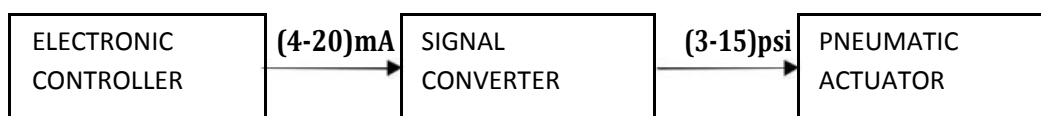

Fig 4.2 Signal Converters

At that place we have to use I to P converters. For this purpose signal converters are used in the middle stage. There are different types of Signal converters are used in Process Industry.

#### 4.2.1 P TO I CONVERTER ( PNEUMATIC TO CURRENT CONVERTER ) :

In this converter ( 3 – 15 psi ) pressure signal is converted into ( 4 – 20 mA ) current signal.

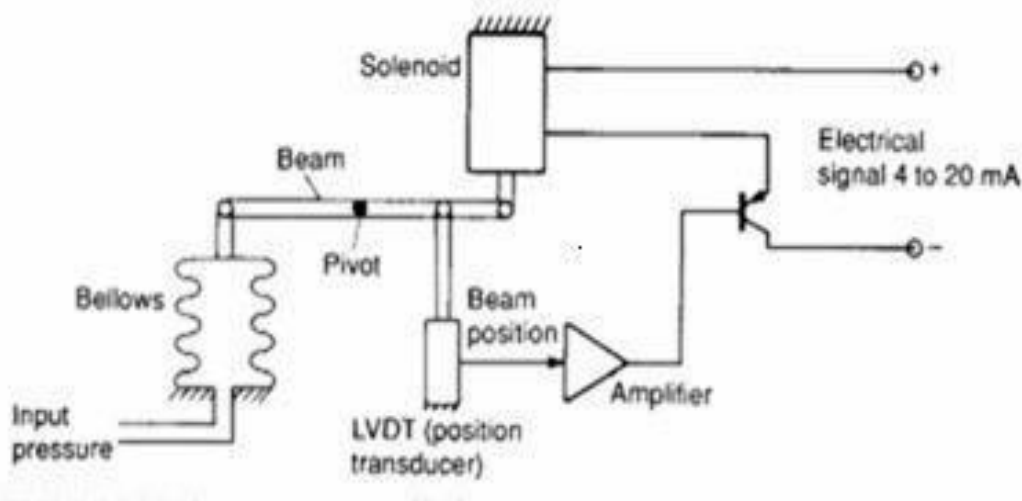

**Fig 4.3 P to I converter**

#### CONSTRUCTION :

The P to I converter consists of the following parts Bellows , LVDT , V to I converter. The input ( Manipulated Signal ) is given to the Bellows. The Bellows is made of elastic materials , which take input as pressure and it gives the output as Linear Displacement.

The output of the Bellows is connected to the LVDT shaft. The LVDT takes the input as Linear Displacement and it gives the output as voltage. The output of the LVDT is given to the voltage to current converter.



**Fig 4.4 P to I Converter**

#### OPERATION :

The Pressure Signal ( 3 – 15 psi ) is given to the Bellows, the Bellows converts the Pressure Signal into Linear Displacement. The output of the Bellows is given to the LVDT. The Displacement is given to the LVDT Shaft.

The LVDT consists of one Primary winding and two Secondary winding depends upon the Bellows output it will be move in Right or Left Position. The corresponding voltage will be induced in Secondary winding. Then the output of the LVDT is given to the voltage to current converter.

The voltage to current converts the voltage into corresponding current value. This current value is proportional to the Manipulated Variable.

#### 4.2.2 I TO P CONVERTER ( CURRENT TO PNEUMATIC CONVERTER ) :

In this converter ( 4 – 20 mA ) current signal is converted into ( 3 – 15 psi ) pressure signal.

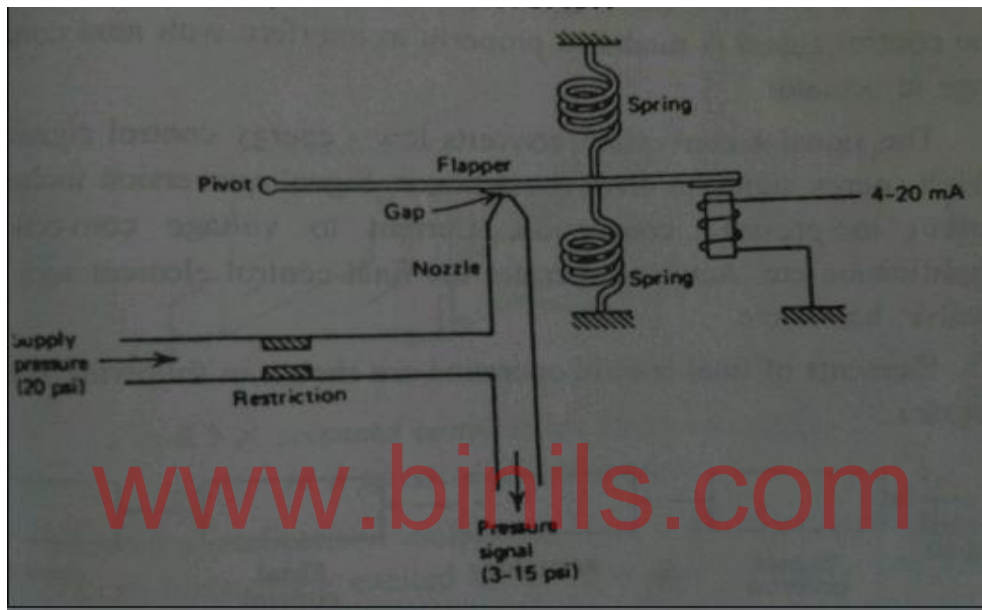

Fig 4.5 I to P Converter

#### CONSTRUCTION & WORKING :

It consists of a current carrying coil , a flapper and nozzle arrangement, control spring arrangement. The spring arrangement is used for calibration process. It uses the principle of a Flapper Nozzle System. The current to be converted is passed through a coil produces a magnetizing force.

A Regulated supply of pressure , usually over 20 psig , provides a source of air through the Restriction. The nozzle is open at the end where the gap exists between the nozzle and flapper and air escapes in this Region. If the flapper moves down and closes off the nozzle opening so that no air leaks , the signal pressure will rise to the supply pressure.

As the flapper moves away, the signal pressure will drop because of the leaking gas. Finally , when the flapper is far away , the pressure will stabilize at some value determined by the maximum leak through the nozzle.

When 4 mA is applied to the coil , the flapper will be far away from nozzle , maximum air leakage through the nozzle opening and the pressure will stabilize at 3 psi.

When 20 mA is applied , the flapper is attracted more. It moves down and closes off the nozzle opening , so that no air leaks.

The signal pressure will rise to 15 psi with minimum leakage of 5 psi. The flapper nozzle system is most commonly used as current to pressure converter. I to P converter translates the 4 to 20 mA current into 3 to 15 psig signal.

#### **4.3 ACTUATORS :**

The Actuator must provide an accurate output position proportional to the input signal in spite of various forces acting on the output member. The most important forces are

1. Inertia forces caused by the mass of moving parts.
2. Static friction forces during impending motion of two adjacent surfaces.
3. Thrust forces caused by weight and unbalanced fluid pressure.

Thus , the Actuator is often required to employ a power – amplifying mechanism. As with automatic controllers , the Actuator may operate by

1. Pneumatic Actuator
2. Hydraulic Actuator
3. Electrical Actuator
4. A combination of these means.

#### **4.3.1 PNEUMATIC ACTUATOR :**

Pneumatic actuators may operate directly from the pneumatic output signal from a pneumatic controller, or they may employ a separate source of compressed air. There are five common methods of operation of pneumatic actuators. These are called

- i. Spring Actuator
- ii. Spring actuator with positioner
- iii. Spring less actuator
- iv. Piston actuator
- v. Motor actuator

#### **I) SPRING ACTUATOR :**

A spring actuator operates directly from the air pressure output of a pneumatic controller in order to provide an output position proportional to the input air pressure.s

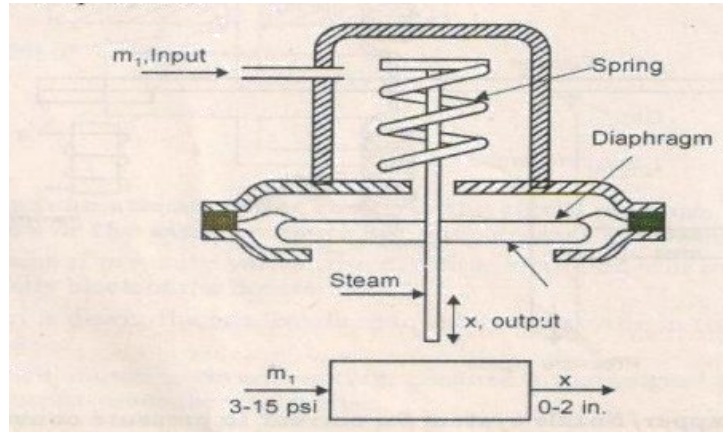

**Fig 4.6 Spring Actuator**

The diaphragm is usually made of fabric – base rubber , molded to form , and supported by backing plate. The input air pressure  $m_1$  acts against the diaphragm and causes a downward force which compresses the spring. At static balance , the force of the air pressure against the diaphragm equals the spring compression force.

$$( m_1 - m_0 ) A = Kx$$

Where,

$m_1$  – input air pressure , lb / in<sup>2</sup>.

$m_0$  – input air pressure at zero stroke , lb / in<sup>2</sup>.

$A$  – effective area of diaphragm , in<sup>2</sup>.

$K$  – spring gradient , lb / in.

$x$  – output ( stem ) displacement , in.

The standard input operating range of spring actuator is 3 to 15 psi gauge. The output displacement or stroke is generally between ¼ and 3 in. And is limited by the allowable stroke of the diaphragm. For longer strokes a piston – spring combination is employed.

The performance of a spring actuator is generally satisfactory providing it is not used under conditions of excessive force on the stem. Inertia forces due to the mass of moving parts must be limited by the natural frequency of the system.

$$f_n = \frac{1}{2\pi} \sqrt{K/M}$$

where,

$f_n$  = natural frequency , cycles / sec

$K$  = spring gradient , lb/in

$M$  = total mass of moving parts , lbsec<sup>2</sup>/in

The natural frequency should be at least 25 cycles per second , otherwise the actuator stem may oscillate continuously when damping is negligible.

Static friction forces must be limited to a low enough value that excessive hysteresis does not result. For hysteresis less than one percent of full travel,

$$F_f < \frac{M_r \cdot A}{100}$$

Where ,

$F_f$  = static friction force, lb

$M_r$  = input operating range , lb/in<sup>2</sup>

This may be a serious limitation. For example , a spring actuator with an effective area of 100 sq in . And an operating range of 3 to 15 psi cannot support more than 12 lb friction if the hysteresis is to remain less than one per cent of full range. Thrust forces are also limited by the ability of the actuator to provide full operating stroke.

$$F_t < m C_i A_i$$

Where  $F_t$  is the total thrust force acting in one direction. This may also be a serious limitation. For Example, a spring actuator with an effective area of 100 sq in . and an initial air pressure setting of 3 psi cannot support more than 300 lb unbalanced force.

In addition, thrust forces must be relatively constant otherwise the stem position will not be directly related to the input air pressure. The performance of a spring actuator is also influenced by the characteristics of the spring and diaphragm.

A well – designed actuator has a linear static relation between input air pressure and output stroke if the effective area of the diaphragm and the spring gradient are constant throughout the stroke. Hysteresis due to the stresses in the spring and diaphragm are usually less than one or two per cent of full stroke.

## II) SPRING ACTUATOR WITH VALVE POSITIONER :

The spring actuator often requires a positioner as shown in fig.4.7 When static friction forces are large or when the response of the motor is too slow. The positioner consists of an input Bellows , a nozzle and amplifying pilot, and the feed back levers and spring . An air supply from 20 to 100 psig must be provided.



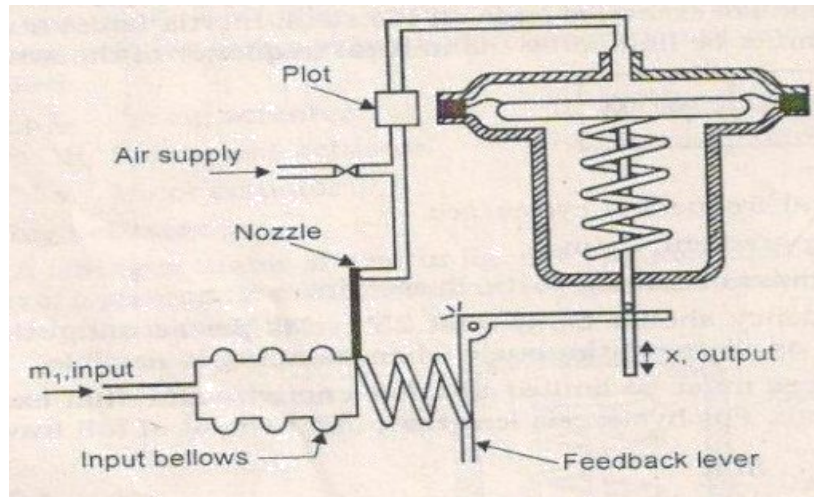

**Fig4.7 Spring Actuator with Valve Positioner**

The operation is as follows , when the input air pressure  $m_1$  increases , the input bellows moves to the right and causes the baffle to cover the nozzle.

The nozzle back- pressure change is amplified by the pilot and is transmitted to the diaphragm. The diaphragm moves down and the feedback lever compresses the spring to return the baffle to a balanced position. Thus the actuator stem assumes a position dictated by the input air pressure. The spring actuator becomes a power means and the characteristics of the spring and diaphragm are relatively less important. The use of the positioner results in several improvements in performance.

1. Hysteresis is reduced and linearity is usually improved because the static operation is governed by the feedback spring and input bellows.
2. The actuator can handle much higher static friction forces because of the amplifying pilot.
3. Speed of response is generally improved because the pneumatic controller must supply sufficient air to fill the small input bellows rather than the large actuator chamber.

### **III) SPRING LESS ACTUATOR :**

The use of a positioner with a spring actuator does not improve the ability of the actuator to handle larger inertia or thrust forces unless special adjustments of motor operating range are made. The only disadvantages in the use of a positioner is that it may require maintenance.

The spring less actuator is useful for large thrust forces. The only difference between the spring less actuator and the spring actuator with positioner ,is that the spring of the actuator is replaced by a pressure regulator which maintains a constant pressure on.



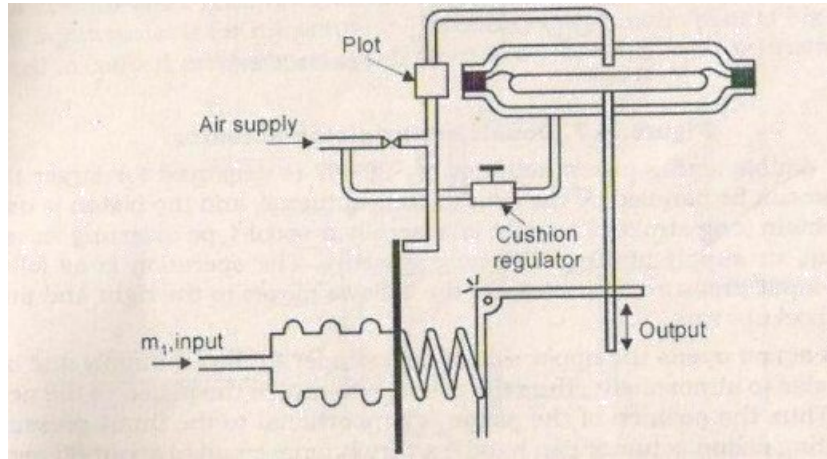

**Fig 4.8 Spring less Actuator**

The underside of the diaphragm an air supply at a pressure of 20 to 100 psig is required . The operation of the spring less actuator is as follows : Assume that the cushion regulator is set to provide 9 psig pressure on the underside of the diaphragm. At static balance and with no thrust force on the actuator stem, the upper side pressure must be 9 psig.

Then if the input pressure increases, the nozzle back pressure increases, and the upper side pressure is raised to a high value. The actuator stem then moves downward and , as the actuator stem attains the new position , the upper side pressure is returned to 9 psig. If there is an upward thrust force on the actuator stem, the underside pressure remains at 9 psig but the positioner raises the upper side pressure until static balance is achieved.

For a downward thrust force the upper side pressure is reduced below 9 psig. Thus , the spring less actuator can counteract a thrust force equal to approximately the underside pressure times the area of the diaphragm. This is generally from three to ten times the thrust force handled by a spring actuator with or without a positioner.

**IV) PISTON ACTUATOR :**

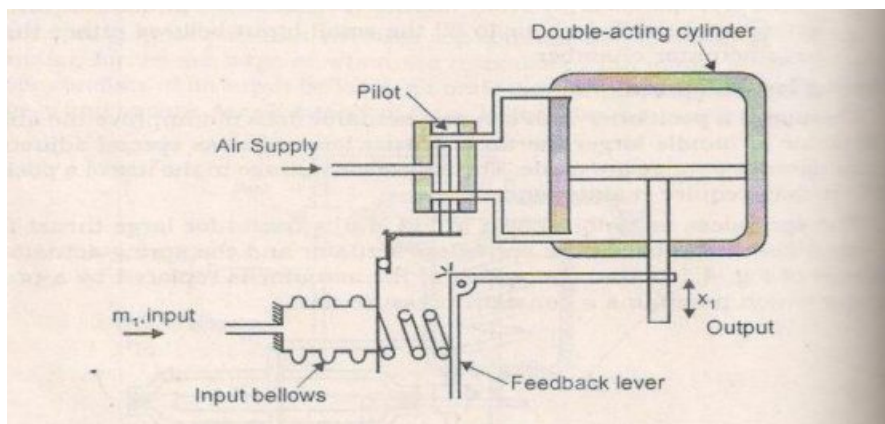

**Fig 4.9 Piston Actuator**

The double – acting piston actuator is employed for larger thrust forces than can be handled by the single acting actuator , and the piston is used in order to obtain long stroke. The pilot is generally a spool type diverting valve and requires an air supply of 30 to 100 psig pressure. The operation is as follows , when the input pressure  $m_1$  increases , the bellows moves to the right and pushes the pilot spool upward.

This action opens the upper side of the cylinder to the air supply and opens the lower side to atmosphere , thus the action is to return the piston to the neutral position. Thus the position of the piston is proportional to the input pressure. A double-acting piston actuator can handle a thrust force equal to about 80 percent of the supply pressure times the area of the piston.

#### V) MOTOR ACTUATOR :

The motor actuator is used for very large thrust force or torque. The air motor is a reversible vane-type or positive – displacement type motor operating from 80 to 100 psig air pressure .The operation is as follows , when the input pressure  $m_1$  increases , the pilot piston moves upward and supplies high pressure to one side of these air motor.

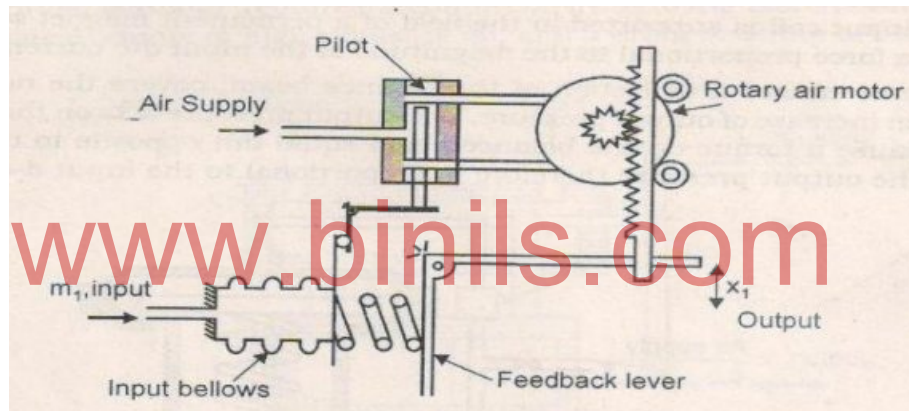
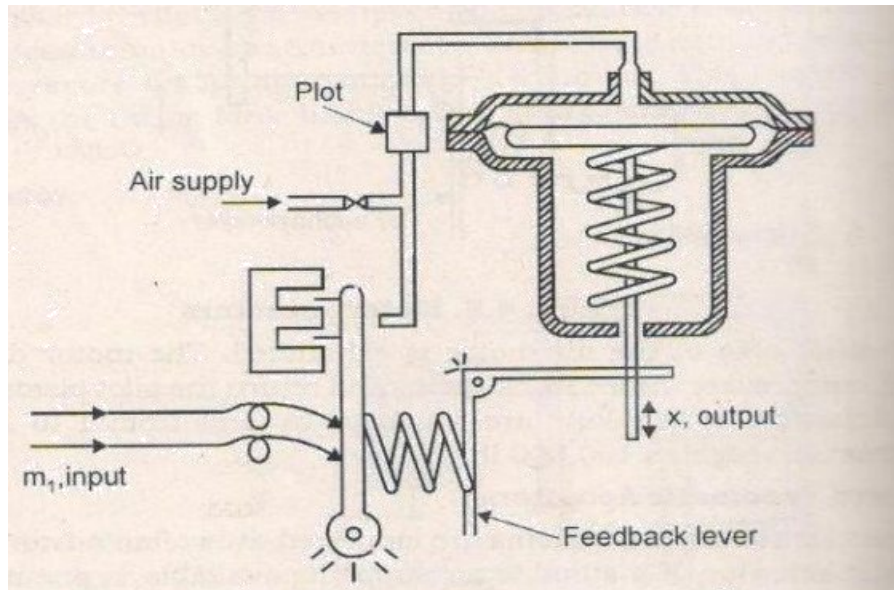

**Fig 4.10 Piston Actuator**

The other side of the air motor is exhausted. The motor drives the rack downward , compresses the feedback spring and return the pilot piston to the neutral position. Actuators of this kind are employed in sizes from 1 to 15 hp and will handle thrusts as high as 100,100 lb.

#### 4.3.2 ELECTRO PNEUMATIC ACTUATOR :

When electric control systems are employed , it is often advantageous to use a pneumatic actuator . If a suitable air supply is available , a pneumatic actuator can provide very large power output and may be operated directly from an electric control system. This requires transducing the electrical output of the controller into an input variable for the actuator. The electro-pneumatic pilot is arranged to convert an electrical signal input to a proportional air pressure output.



**Fig 4.11 Electro Pneumatic Actuator**

The input electric signal ( usually a direct current ) enters the ' voice - coil ' motor. The input coil is supported in the field of a permanent magnet so that the coil affords a force proportional to the magnitude of the input dc current.

The force causes a deflection of the balance beam, covers the nozzle, and results in an increase of output pressure. The output pressure acts on the feedback bellows to cause a torque on the balance beam equal but opposite to that of the voice coil. The output pressure therefore is proportional to the input DC current.

The electro Pneumatic comparator combines the voice coil and the pilot in the positioner of a pneumatic comparator. The motion of the output of the actuator is related to the balance beam through the feedback lever. The output position of the actuator is therefore proportional to input DC current.

### 4.3.3 HYDRAULIC ACTUATOR :

Hydraulic actuator , as used for industrial process control , accept a signal from a pneumatic controller or an electric controller and employ hydraulic pressure to drive an output member. The hydraulic actuator is used where high speed and larger forces ( or large power ) are required.

The hydraulic piston actuator has as its input  $m_1$ , the position of the vertical lever. For a pneumatic - hydraulic actuator the input would be the position of a bellows.

The balance lever pivots at the bottom so that an increase of input ( to the left ) pushes the pilot piston to the left. This action opens the left end of the piston to supply pressure and opens the right end of the piston to drain

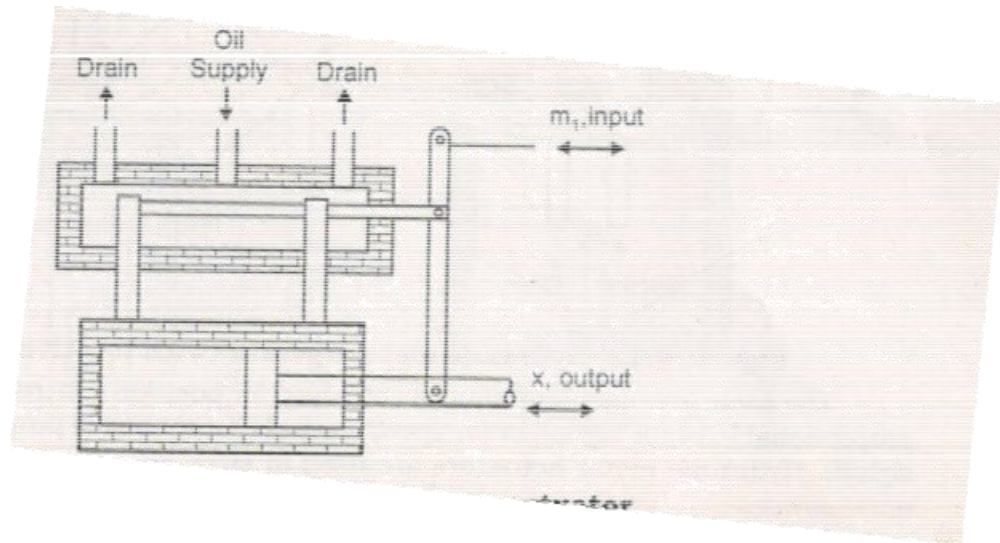
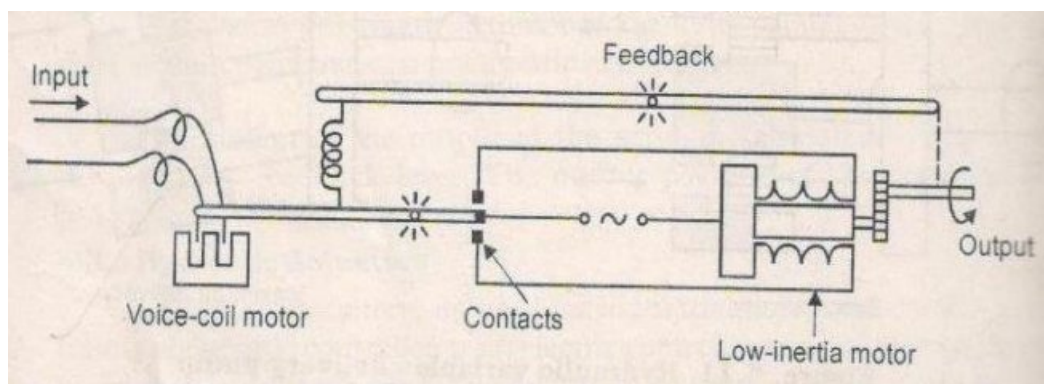

**Fig 4.12 Hydraulic Actuator**

The large power piston, therefore, moves to the right until, as the balance lever rotates about the top most end, the pilot piston is returned to center, the motion of the output  $x_1$ , is therefore proportional to the input motion  $m_1$ . The hydraulic actuator requires a continuously running electric motor and pump to provide a source of pressure oil, and a drain or sump to collect the return.

#### 4.3.4 ELECTRIC ACTUATOR :

The input device is the voice-coil motor which positions a three-land pilot spool. The pilot controls the flow of oil to the cylinder, and the piston actuates the spring feedback to the pilot spool. The operation follows: An increase in current to the voice coil causes the arm to swing downward thereby pushing down the pilot spool.



**Fig 4.13 Electric Actuator**

This action connects the lower side of the cylinder to drain and connects the upper side to supply pressure. The piston then moves downward, and the feedback spring pushes back to rebalance the system in equilibrium. The position of the piston rod is therefore proportional to input direct current.



#### 4.4 CONTROL VALVES:

Control valve is a variable restriction in a pipe line. Two operating principles for automatic control valves are,

1. A fluid throttling control valve cannot operate with minimum differential head.
2. The differential head at a fluid – throttling control valve is never arbitrary.

It regulates flow rate in a process control system. It is one of the final control elements, which regulate level of energy of a process. They are widely used in variety of industries including chemical, Fertilizers, Paper and Pulp, Petro chemicals, Pharmaceuticals etc.

#### Construction:

Main parts of a control valves are

- i) Valve Body
- ii) Valve Stem
- iii) Valve Plug

#### i) VALVE BODY :

Materials for valve body are used in accordance with performance of requirement of Pressure, Temperature and Corrosion etc.

Commonly used materials are iron, cast steel, stainless steel and Bronze.

#### ii) VALVE STEM:

The valve stem is nothing but a vertical metallic Shaft or Rod.

#### iii) VALVE PLUG:

The valve plug is screwed into stem and then pinned. It can be a single seated plug which is guided at the top and bottom.

According to their basic shape plugs can be classified as Disc, V – Shape, and contoured plugs.

#### 4.5 TYPES OF VALVES:

a) According to the characteristics:

- i) Quick Opening
- ii) Linear
- iii) Equal Percentage

b) Pneumatic Valve (or) Electrically Operated Valve (or) Solenoid Valve

c) Manually Operated Valve (or) Automatic Valve

d) Sliding Stem Valves:

- i) Butterfly Valves

- ii) Rotating Plug Valves
- iii) Lifting Gate Valves
- e) Rotating Shaft type Valves:
  - i) Butterfly Valves
  - ii) Rotating Plug Valves
  - iii) Lowers
- f) Direct acting (or) Reverse acting Valve

#### 4.5.1 VALVE CHARACTERISTICS:

The relationship between percentage flow versus percentage stem travel. According to valve characteristic control valves as classified as,

- i) Quick Opening Valve
- ii) Linear Valve
- iii) Equal Percentage Valve

By shaping plug and seat various valve characteristics can be obtained. Valve Characteristics as shown in fig.4.14

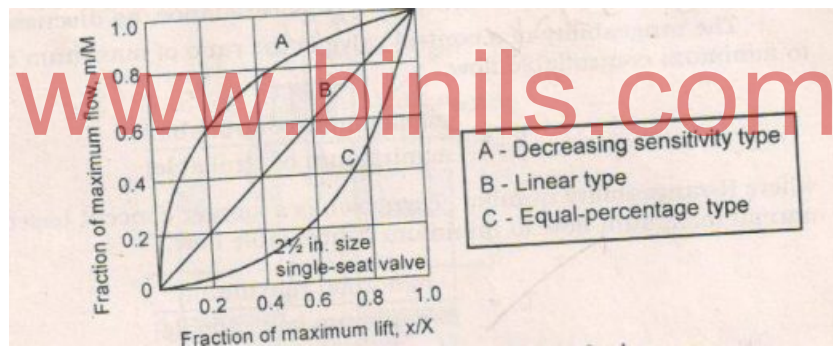

**Fig 4.14 Valve Characteristics**

#### I) QUICK OPENING VALVE:

A quick opening valve plug produces a large increase in flow for a small initial change in stem travel. Near maximum flow is reached at a relatively low percentage of maximum stem lift. Quick opening plugs are normally utilized in two position “ON-OFF” applications but may be used in some linear valve applications. This is possible because of its initial linear characteristics at a low percentage of stem travel. The slope of this linear region is very steep which produces a higher initial gain than the linear plug but also increases the potential instability of the control valve.

#### ii) LINEAR :

This characteristic provides a linear relationship between the valve position and the flow rate. The flow through a linear valve varies directly with the position of the valve stem. The flow-travel relationship, if plotted on rectilinear coordinates, approximates a

straight line, thereby giving equal volume changes for equal lift changes regardless of percent of valve opening.

These valves are often used for liquid level control and certain flow control operations requiring constant gain.

### iii) EQUAL PERCENTAGE:

The equal percentage valve plug produces the same percentage change in flow per fixed increment of valve stroke at any location on its characteristics curve. For example, if 30% stem lift produces 5gpm and a lift increase of 10% to 40% produces 8gpm or a 60% increase over the previous 5gpm, then a further stroke of 10% now produces a 60% increase over the previous 8gpm for a total flow of 12.8gpm.

These types of valves are commonly used for pressure control applications and are most suitable for applications where a high variation in pressure drop is expected.

### 4.5.2 i) PNEUMATIC VALVES:

The Pneumatic output from controller is sensed by a Diaphragm. The force on the diaphragm is balanced by a force due to control spring.

The valve stems moves up or down as the input signal changes. It contains the throttling mechanism, which consists of a plug attached to a valve stem and the valve seat which is built in to the body.

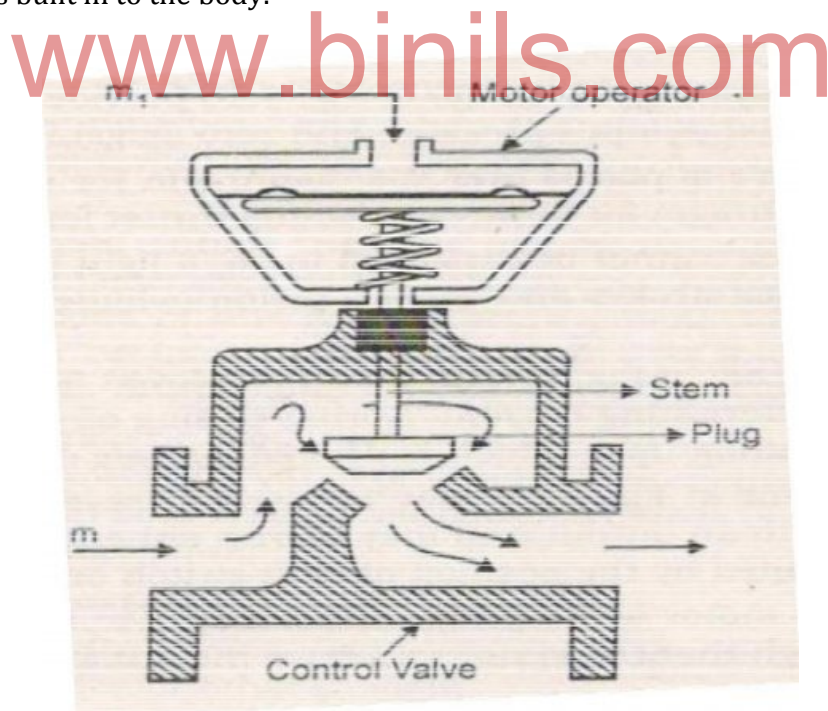

**Fig4.15 Pneumatic Valves**

The valve stem displacement is limited by allowable stroke by the diaphragm. The vertical movement of the plug and stem of the control valve changes the area of opening of the port. The flow rate of the fluid passing through the port is therefore proportioned or throttled by positioning the valve stem.



The equation governing the flow of fluid through a restriction such as a valve may be derived from the laws of fluid mechanics. For a control valve, the flow rate of liquid is assumed to be given by

$$m = K_1 a \sqrt{2g(h_1 - h_2)}$$

where,

$m$  = flow rate,  $\text{ft}^3/\text{sec}$

$K_1$  = a flow coefficient

$a$  = area of control valve port,  $\text{ft}^2$

$g$  = acceleration due to gravity,  $\text{ft}/\text{sec}^2$

$h_1$  = upstream static head of flowing fluid, ft

$h_2$  = downstream static head of flowing fluid, ft

## ii) SOLENOID VALVES:

A solenoid is a device that converts an electrical signal into mechanical motion. The solenoid valve consists of a coil and plunger. The plunger is either spring loaded or free standing.

The coil has a voltage and current rating. It can be excited by AC or DC voltage. Direct current solenoid is widely employed for two position control with either alternating current. Spring-closing or Spring-opening types may be selected depending upon which is desired for safe operation.

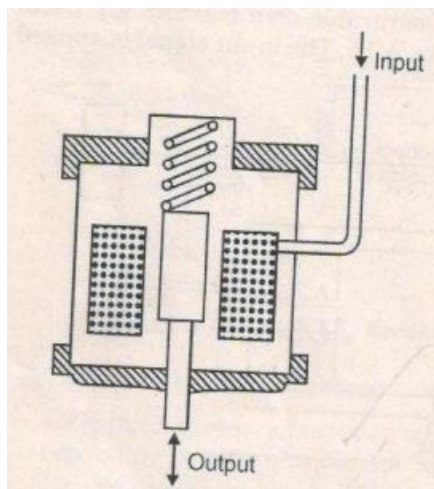

**Fig 4.16 Solenoid Valves**

Its specification also includes push force or pull, when excited at a specific voltage. Solenoid coil may be rated for continuous operation or intermittent operation.

## ADVANTAGES:

1. Solenoid valve is a ON-OFF type.
2. It has no sliding parts.
3. It can be noise less.
4. It can provide 100 percent tight shut off.
5. It is un affected by vibration.
6. It has a compact Design.

### 4.5.3 SLIDING STEM CONTROL VALVE (OR) SPLIT RANGE CONTROL VALVE:

Control valves in which the plug is operated by means of reciprocating motion are termed sliding-stem valves and are of the following types:

1. Single -seat plug valves.
2. Double-seat plug valves.
3. Lifting-gate valves.

#### 1. SINGLE- SEAT PLUG VALVES:

The single -seat plug valve has only one port opening between seat and plug and the entire flow passes through this port.

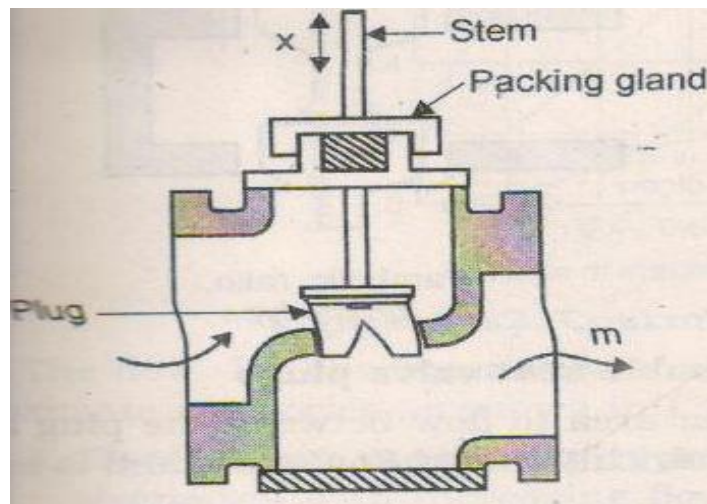

**Fig4.17 Single Seat Plug Valves**

It has the following features:

1. It is simple in construction.
2. It can be shut off to provide zero flow.
3. There is a large force acting on the valve stem because of the differential head acting across the port and seat area.

## 2. DOUBLE-SEAT PLUG VALVES:

The double-seat plug valve has two port openings and two seats and two plugs. The port openings are not usually identical in size.

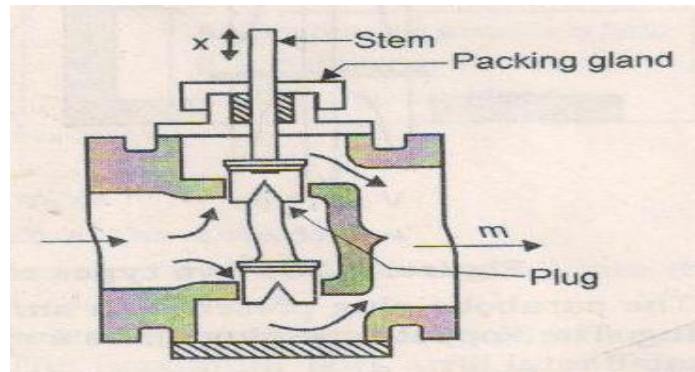

**Fig 4.18 Double Seat Plug Valves**

It has the following features:

1. Net force acting on the valve stem is generally small.
2. It cannot be shut off tightly because of differential temperature expansion of valve plug and valve body.

### Types of Plugs:

A few types of plugs for single seat and double seat valves are shown in fig.4.19. The piston type plug has one or more grooves along its length and the flow passes vertically in the grooves between the plug and seat ring.

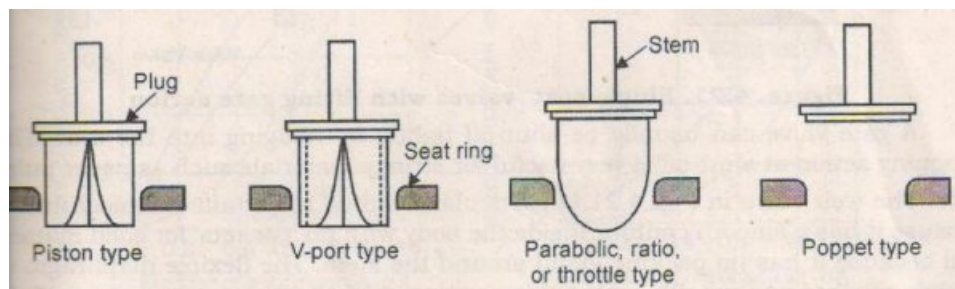

**Fig 4.19 A few types of Single seat valve plugs**

The V-Port type is open on the inside and the flow passes horizontally through the triangular shaped area over the seat ring.

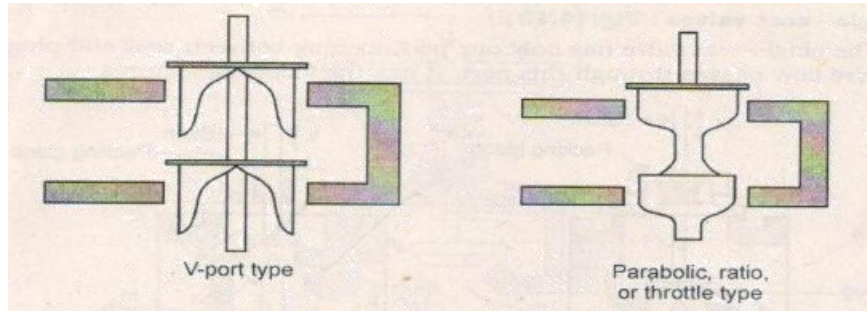

**Fig 4.20 Two types of double seat valve plugs**

The parabolic plug presents an annular area to flow between the plug and seat ring. The poppet-type plug offers a cylindrical – shaped flow area and is used with small total lift.

### 3. LIFTING GATE VALVES:

The gate valve is often used for fluids containing solid matter, because it presents an open area directly to the flow of fluid and does not involve a change of direction of flow stream.

A gate valve can usually be shut-off tightly by wedging into the seat. The chopping action at shut-off is very useful for stringy materials such as paper pulp.

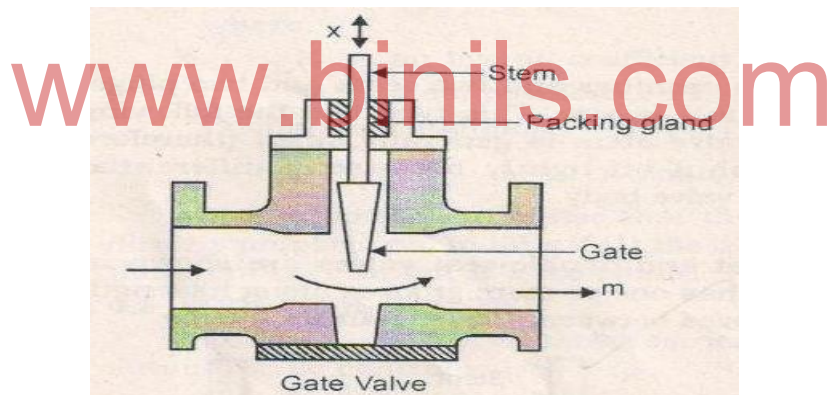

**Fig 4.21 Gate valves**

### 4.5.4 ROTATING - SHAFT CONTROL VALVE ( OR ) ELECTRIC MOTOR ACTUATED CONTROL VALVE :

Control valves in which the restriction is accomplished by the rotation of a plug or vane may be called rotating – shaft type. These are ,

1. Rotating –plug valves
2. Butterfly valves
3. Louvers

## 1. ROTATING -PLUG VALVES:

The rotating-plug valve is illustrated in fig.4.22 The plug is a cylindrical or conical element with a transverse opening. It is rotated in the valve body by an external lever so that the opening on one side of the plug is gradually covered or uncovered. The shape of the opening or port may be circular , V - Shape , rectangular, or any form that is desired to produce a given flow-angle characteristics

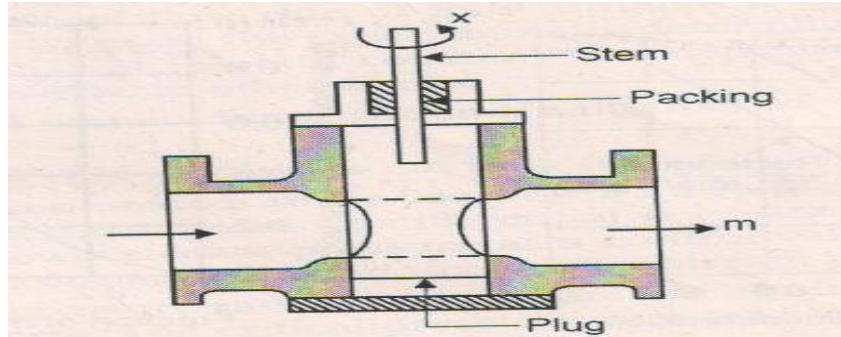

**Fig4.22 Rotating Plug valves**

A rotating plug valve having a conical plug can generally be closed tightly and has high range ability. This type of valve is often employed for throttling the flow of oil to burner systems.

## 2. BUTTERFLY VALVES:

The butterfly valves is consists of a single vane rotating inside a circular or rectangular pipe or casing.

The shaft projects through the casing and may be operated externally. The total rotation of the vane is usually restricted to about 60 degrees, because the additional 30 degrees does not produce much further increase in flow.

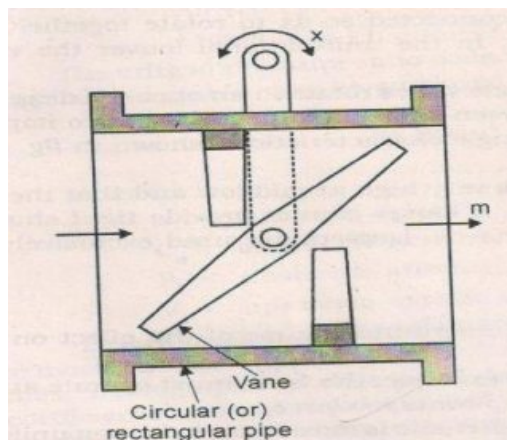

**Fig 4.23 Butterfly valves**

The V-port butterfly valve incorporates a V-slot in the body so that rotation of the vane opens a portion of the V-slot. The flow-angle characteristics is shown in fig for a 60 degrees butterfly valve.



The range ability may vary from 5 to 50 and tight shut-off may be obtained with special design. The butterfly valve is most often employed in sizes from 4 to 60 in. for the control of air and gas. It is also used for liquid flow if the pressure differential is not large.

### 3. LOUVERS:

It consists of two or more rectangular vanes mounted on shafts one above the other and interconnected so as to rotate together. The vanes are operated by an external lever. In the uni rotational louver the vanes remain parallel at all positions.

In a counter rotational louver alternate vanes in an opposite direction. Flow guides are sometimes installed between adjacent vanes in order to improve the effectiveness of throttling. It may be seen that the sensitivity is very high at mid flow and that the last 30 deg of rotation is relatively ineffective.

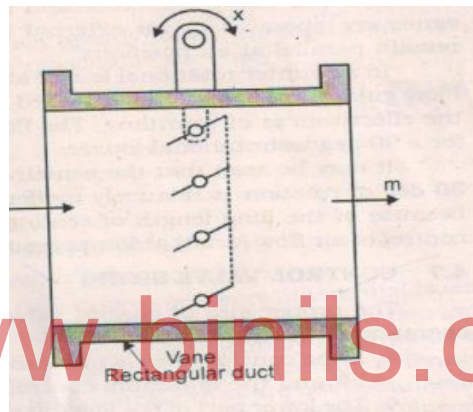

**Fig 4.24 Louvers**

A louver cannot provide tight shut-off because of the long length of seating surfaces. Louvers are used exclusively for control of air flow ( draft ) at low pressure.

### 4.6 CONTROL VALVE SIZING :

1. Valve coefficient (or)  $C_v$  rating
2. Range ability
3. Turn down

#### 4.6.1 VALVE COEFFICIENT ( or ) $C_v$ RATING :

Flow through orifice is given as

$$Q = K \sqrt{\Delta P} F_1$$

Where,

$K$  = Proportionality constant

$\Delta P$  = Pressure difference

Correction to this equation is required due to non-ideal characteristics of flow materials. The correction factors allow selection of proper size of valve. This correction factor is known as

“ Cv RATING “ or “ Valve coefficient “ .

It is defined as the flow of water in gallons per minute for a pressure drop of 1 psi across wide open valve.

Using the correction factor , flow rate can be expressed as

$$Q = C_v \sqrt{\frac{\Delta P}{S_g}}$$

Where ,

Q = Flow rate in gallons per minute

$\Delta P$  = Pressure drop across control valve

$S_g$  = Specific gravity of liquid

Typical value of Cv for different valve size are indicated in the following table.

Valve size in inches	Cv	Valve size in inches	Cv
1/4	0.3	3	108
1/2	3.0	4	174
1	14.0	6	400

#### 4.6.2 RANGEABILITY:

The rangeability of a control valve is the ratio of maximum controllable flow to minimum controllable flow.

$$R = \frac{m (\text{maximum controllable flow})}{m (\text{minimum controllable flow})}$$

Where ,

R = Rangeability number.

#### 4.6.3 TURNDOWN:

Turndown is a similar concept based on the ratio of normal maximum flow to minimum controllable flow.

$$T = \frac{m (\text{normal maximum flow})}{m (\text{minimum controllable flow})}$$

Normal maximum flow is generally taken as 70 percent of maximum flow so that



$$T = 0.7 R$$

The minimum controllable flow of control valve depends upon its construction, clearances must be allowed in order to prevent binding and sticking and the flow through these clearances constitutes the minimum controllable flow.

The minimum controllable flow for a single seat valve is not zero unless the throttling seat and shut-off seat are identical and have perfect alignment. The rangeability of a sliding stem control valve is usually between 20 and 70.

The importance of rangeability and turndown lies in the application of the control valve. For example, if the design of an burner and furnace requires a 30 to 1 range of oil flow to accommodate various loads on the furnace, the turndown must be at least 30 and the rangeability must be at least 43.

#### 4.7 SELECTION OF CONTROL VALVE:

1. For the particular process under control, determine,

a) The maximum value of flow rate required to sustain the controlled variable under any condition of process operation. This is the normal **maximum flow rate**.

b) The value of flow rate that will be required most of the time. This is **the normal flow rate**.

c) The minimum value of flow rate required to sustain the controlled variable under any conditions or process operation. This is the normal **minimum flow rate**.

2. Select the maximum flow rate which the control valve is to provide. This is generally based on the normal maximum flow rate of about 70 percent of maximum flow rate. The additional flow is a factor of safety which allows for low estimation of pressure losses and high estimation of valve flow rate. The maximum flow rate usually selected is about 1.4 times the normal maximum flow.

3. Select the style and type of control valve to provide best operation for the fluid to be handled. Check the rangeability to insure that the minimum controllable flow is generously smaller than the normal minimum flow rate desired.

4. Calculate the pressure differential at the control valve at the maximum flow. This requires calculating line pressure losses, flow equipment pressure losses, and determining upstream head from pump or fan characteristic curves.

5. Determine the control valve size from manufactures charts, or slide- rules. If the fluid viscosity is high, or line velocities are exceptionally low ( Reynolds number in the pipe line less than about 10,000 ) the size coefficient  $C_v$  will be low, and the manufacturer should be asked to determine the valve size.

6. Calculate the characteristic coefficient:

$$\alpha = \frac{\text{Differential pressure with control valve wide open}}{\text{Differential pressure with control valve closed}}$$

The control valve installation to determine whether the differential head can be increased by selecting larger pumps, larger line sizes or minimizing losses in series flow equipment.

The flow coefficient ' K ' and port area ' a ' are different for every style or size of control valve.

7. Such as corrosion, abrasion, temperature and pressure. The valve must be able to cope with these factors.

8. Whether the fluid contains suspended particules.

9. Whether tight shut-off is required or not.

10. Fluid characteristics such as viscosity, Density, specific gravity are also considered.

#### 4.8 CAVITATION AND FLASHING:

Under normal conditions, fluid passing through a valve will undergo a pressure drop across the valve orifice. The point of lowest pressure is called " Vena contracta". The figure 4.25 shows the pressure drop and recovery in the pipe line.

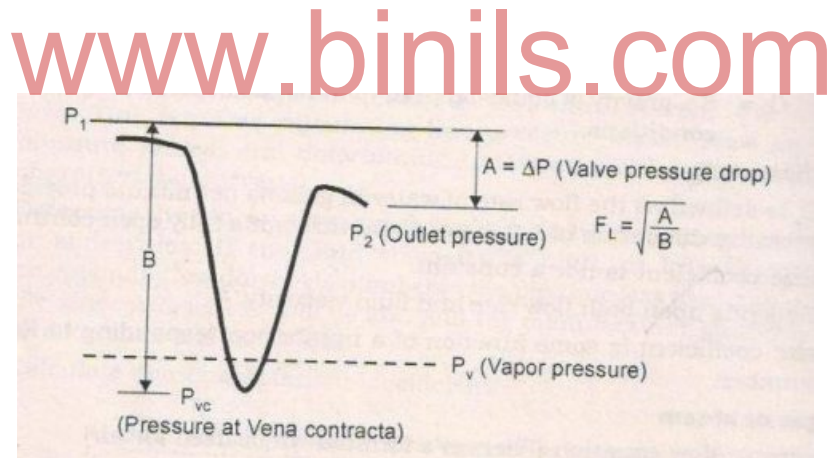

**Fig 4.25 Cavitations and Flashing**

$P_1$  is the fluid pressure at the inlet and  $P_2$  is the exit pressure and  $P_v$  is the vapor pressure of the fluid.

When the fluid passes the valve there is a pressure drop and fluid pressure partially recovers and line pressure is again increased. The difference in pressure is

$$\Delta P = P_1 - P_2$$

The cavitations and flashing are undesirable phenomenon and hence it should be avoided.

#### **4.8.1 CAVITATIONS:**

It occurs in a valve when the pressure drop across the orifice result in pressure less than liquid vapor pressure and then recover to above the vapor pressure. The pressure recovery causes an implosion, or collapse of the vapor formed at the vena contracta.

#### **EFFECTS:**

The cavity collapse produces shock waves and liquid microject. These impacts on the adjacent surface of valves, pipes, and erosion damage can occur which reduces wall thickness. Cavitations produces high level of noise and vibration. Excessive vibration can loose, damage piping support, structure, and process equipment.

#### **PREVENTATION:**

An effective combination of system design, valve selection, and material selection can minimize or eliminate the unwanted effects of cavitations.

#### **FLASHING:**

It occurs in a valve, when the pressure at vena contract drops to less than the inlet pressure  $P_1$ , outlet pressure  $P_2$  is also less than the fluid pressure. The fluid enters the valve as a liquid and exits as a vapor. The inlet pressure  $P_1$  is less than vapor pressure.

#### **EFFECTS:**

High velocities and mixed phase flow at generated by the expansion of liquid into vapor. Which can cause erosion and tuning of pressure boundary walls. Flashing generate excessive vibration associated with high velocity flow.

#### **PREVENTION:**

By reducing velocity and using erosion material or effective design can minimize the damage from flashing.

-----

#### **REVIEW QUESTION :**

#### **PART- A ( 2 marks )**

1. State the Control Valve Characteristics .
2. Define Actuator.
3. Mention the different Signal Convertors.
4. What can limit the flow through the control valve.
5. Give the output range of P to I convertor.
6. List the 3 major parts of a Pneumatic Control Valve.
7. What is I to P convertor.

8. Mention any two types of control Valve.
9. Write any one reason for Selecting Proper size of Control Valve.
10. What is the Output and Input range of I to P convertor.
11. Draw the Inherent characteristics of Control Valve.

**PART – B ( 3 marks )**

1. What is split range control valve.
2. Give the Expression for control valve sizing Equation.
3. List the characteristics of Control Valve.
4. Define Cv Rating.
5. Mention any 3 Pneumatic Actuator.
6. What is the Types of Actuator.
7. When do you use of Valve Positioner.
8. What is meant by Oscillation?
9. What is P to I Convertor?
10. What is Range ability?

**PART – C ( 10 marks )**

1. Describe control valve Characteristics.
2. Explain Electric Motor Actuated Control Valve.
3. Explain Signal Converter with Diagram.
4. Describe about the Effect of Flashing and Cavitations in Control Valve.
5. Explain the working of an Electro Pneumatic Actuator with a Diagram.
6. What is Valve Positioner?. List the different types of Valve Positioner and mention its Application.
7. Describe in detail the working of Split Range Control Valve.

## **UNIT V -COMPLEX CONTROL SYSTEMS**

Feed forward control system, Feed forward control of heat exchanger. Comparison of feedback control system and feed forward control system. Ratio control – examples – Cascade control – cascade control of heat exchanger –cascade control of distillation column. Direct digital control (DDC) of single loop, direct digital control with multiple control loops.

---

### **--- 5.1 ADVANCED CONTROL SYSTEMS**

Feedback control is the type of control encountered most commonly in industrial processes and particularly in chemical processes. But it is not the only one used in industries. There exists a situation where feedback control action is insufficient to produce the desired response of a given process. In such cases other control configurations such as feed forward, ratio, cascade, override, adaptive, split range, and auctioneering, inferential and multivariable controls are used.

The feedback control configuration involves one output (measurement) and one manipulated variable in a single loop. The other control configurations mentioned above may use more than one measurement and one manipulation or one measurement and more than one manipulated variables. In such cases control systems with multiple loops may arise. These control systems involve loops that are not separate but share either the single manipulated variable or the only measurement.

The systems with a single manipulated input and single controlled output are called 'Single-Input Single Output' systems (SISO). Chemical processes usually have two or more controlled outputs, requiring two or more manipulated variables. Such control systems are called 'Multiple Input and Multiple Output' systems (MIMO).

### **5.2 FEED FORWARD CONTROL SYSTEM**

Feedback control system measures the controlled variable, compares that measurement with the set point or reference, and if there is a difference between the two, change its output signal to the manipulated variable in order to eliminate the error. This means that feedback control cannot anticipate and prevent errors; it can only initiate its corrective action after an error has already developed. Thus we can conclude that feedback control loops can never achieve perfect control of a process, that is, keep the output of the process continuously at the desired set point value in the presence of load or set point changes.

The feed forward control configurations react to variations in disturbance variables (or set point), predict the disturbance's effects and take corrective action to eliminate its impact on the process output. Therefore, the feed forward controllers have the theoretical potential for perfect control. But, as it is difficult to measure all possible disturbance variables and to predict their effect quantitatively, feed forward control is generally used along with feedback control.

The feed forward system is more costly and requires more engineering effort than a feedback system.

### 5.2.1 STRUCTURE OF FEED FORWARD CONTROL SCHEME

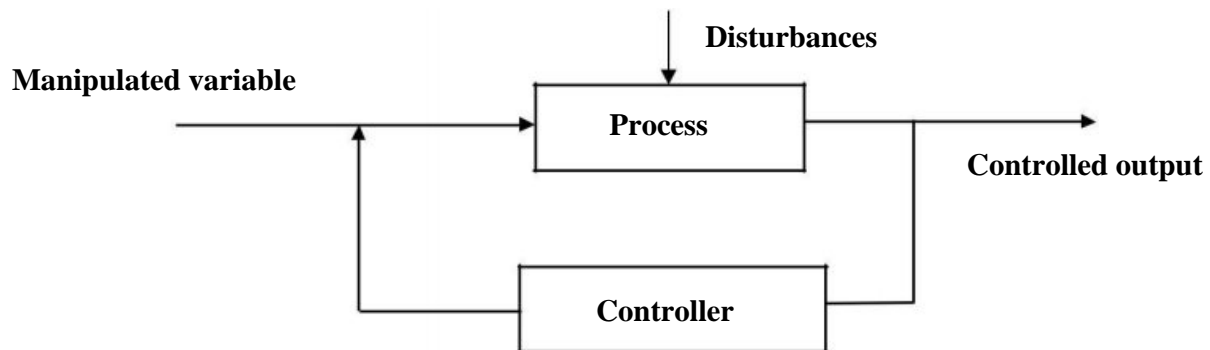

Fig 5 .1 Structure of feedback control scheme

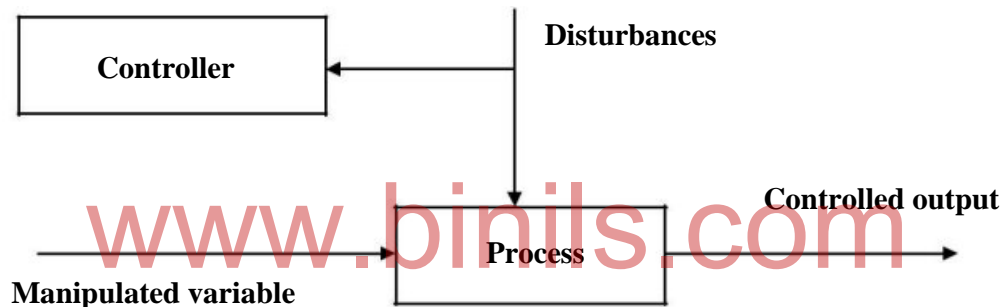

Fig 5 .2 Structure of feed forward control scheme

Fig 5 .1 shows a typical schematic of a feedback control system. In comparison to that we can see the general form of a feed forward control system in Fig 5.2. It measures the disturbance directly and then it anticipates the effect that it will have on the process output. Subsequently, it changes the manipulated variable by such an amount as to eliminate completely the impact of the disturbance on the process output (controlled variable). Control action starts immediately after a change in the disturbance has been detected. It is clear from the Figs. 5.1 and 5.2 that feedback acts 'after the fact', in a compensatory manner, whereas feed forward acts 'beforehand' in an anticipatory manner.

### 5.2.2 FEED FORWARD CONTROL OF HEAT EXCHANGER

1. A heat exchanger exchanges heat between two streams, heating one and cooling the other.
2. Heat can be transferred between the same phases (liquid to liquid, gas to gas etc) or phase change can occur on either the process side (condenser, evaporator, reboiler etc) or the utility side (steam heater) of the heat exchanger.
3. The objective is to keep the exit temperature of the liquid constant by manipulating the steam pressure.

4. There are two principal disturbances (loads) that are measured for feed forward control: liquid flow rate and liquid inlet temperature. Feed forward control can be developed for more than one disturbance also.

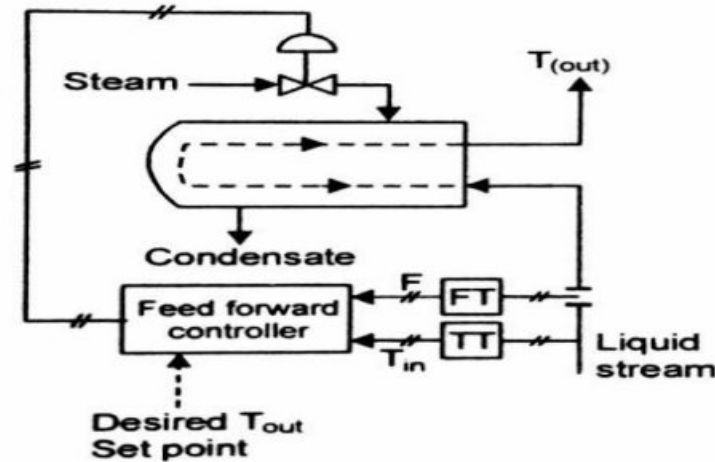

Fig 5 .3 Heat exchanger

5. The controller acts according to which disturbance changed value. Fig 5.4 represents the general case of feed forward control with several loads (disturbances) and a single controlled variable.

6. The major components of load are entered into a model to calculate the value of the manipulated variable required to maintain control at the set point.

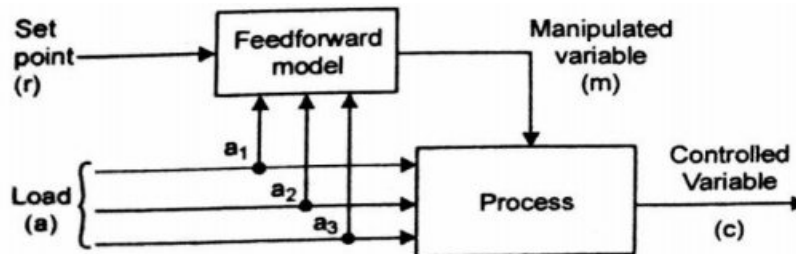

Fig 5 .4 Feed forward control loop

### 5.2.3ADVANTAGES AND DISADVANTAGES OF FEED FORWARD CONTROL SYSTEM

#### Advantages

1. Corrective action is taken as soon as disturbances arrive.
2. Controlled variable need not be measured.
3. Does not affect the stability of the processes

#### Disadvantages

1. Load variable must be measured
2. A process model is required



3. Errors in modelling can result in poor control

### 5.3 COMPARISON OF FEEDBACK CONTROL SYSTEM AND FEED FORWARD CONTROL SYSTEM.

S.NO	FEED FORWARD	FEED BACK
1.	Requires identification of all possible disturbances and their direct measurement	It does not require identification and measurement of any disturbance.
2.	It does not introduce instability in the closed loop response	It may create instability in the closed loop response
3.	Sensitive to process parameter variations	It is insensitive to process parameter changes
4.	Acts before the effect of a disturbance has been felt by the system	It waits until the effect of the disturbances has been felt by the system, before control action is taken.
5.	Is good for slow systems or with significant dead time	It is unsatisfactory for slow process or with significant dead time
6.	It produces stable response	It causes oscillatory response.

### 5.4 RATIO CONTROL SYSTEM

Ratio control is a special type of feed forward control where two disturbances are measured and held in a constant ratio to each other. Many industries require feed in specific ratio, examples being air –fuel ratio in burner's reactants ratio to blending unit and reactors.

It is mostly used to control the ratio of flow rates of two streams. Both flow rates are measured but only one can be controlled. The stream whose flow rate is not under control is usually referred to as 'wild stream'.

Figure 5.5 shows two different ratio control configurations for two streams. Stream A is the wild stream. In configuration 1 we measure both flow rates and take their ratio. The ratio is compared to the desired ratio (setpoint) and the deviation (error) between the measured and desired ratios constitutes the actuating signal for the ratio controller.

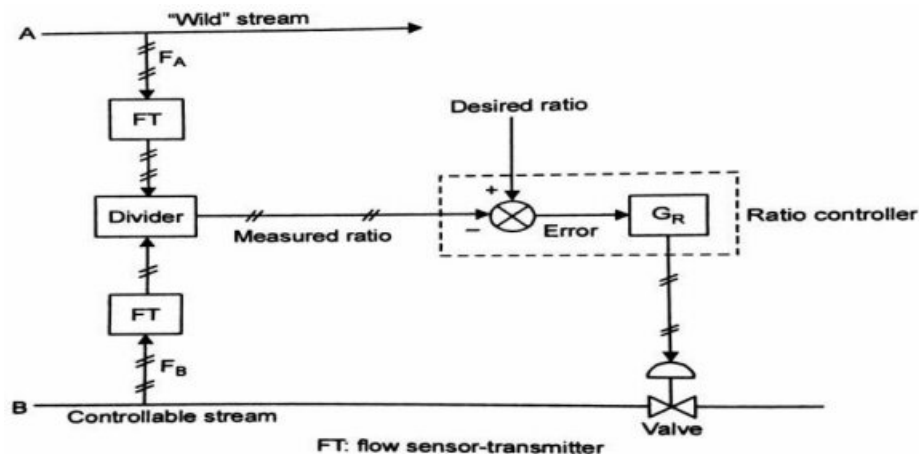

Fig 5.5 Configuration 1

In configuration 2 we measure the flow rate of the wild stream and multiply it by the desired ratio the result is the flow rate the stream B should have and constitutes the set point value which is compared to the measured flow rate of stream B. The deviation constitutes the actuating signal for the controller which adjusts appropriately the flow of stream. As the magnitude of the wild stream flow changes the set point of the controller is automatically moved to new value by the ratio settler so that an exact ratio is maintained between flow rates of stream A and stream B.

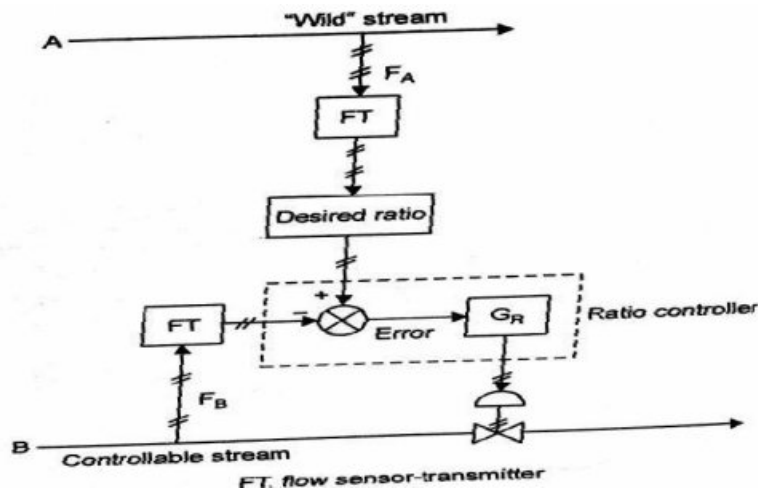

Fig 5.6 Configuration 2

### 5.4.1 RATIO OF TWO REACTANTS

A most common ratio control is to control the ratio of two reactants entering a reactor at a desired value. In this case, one of the flow rates is measured but allowed to flow, that is not regulated, and the other is both measured and controlled to provide the specified constant ratio.

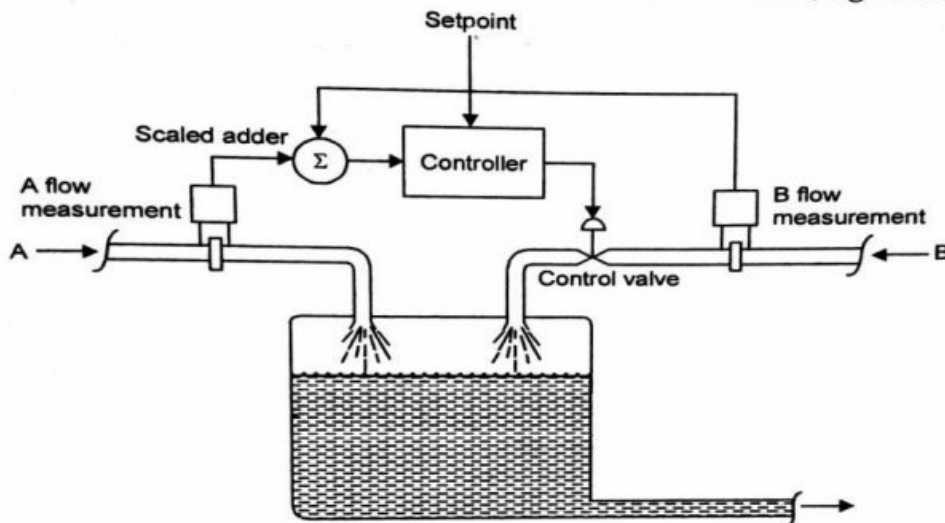

Fig 5.7 Ratio of two flow rates

An example of this system is shown in figure.5.7 The flow rate of reactant A is measured and added with appropriate scaling, to the measurement of flow rate B. The controller reacts to the resulting input signal by adjustment of the control valve in the reactant B input line. This configuration is similar to the one discussed as configuration2

#### 5.4.2 FUEL AIR RATIO CONTROL

This ratio control is used to keep the ratio of fuel/air in a burner at its optimum value. This is to make sure the proper combustion of the fuel with the just required optimum value. This is to make sure the proper combustion of the fuel with the just required amount of air. The control the temperature of a furnace , the fuel demand is controlled by a cascade controller as discussed in section.

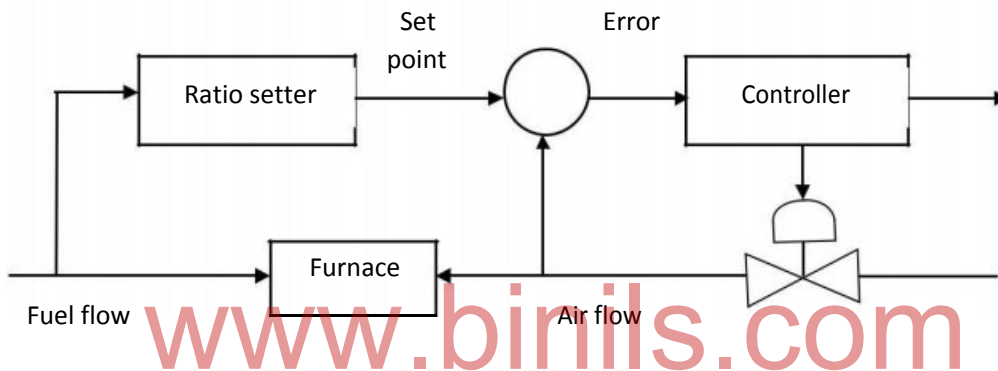

Fig 5 .8 Fuel/Air ratio control

This ratio controller may be used in series with temperature controller. The fuel flow rate measured as secondary variable can be used here as wild stream flow rate and given ratio setter. The output of the ratio setter is the set point for the ratio controller which in turn changes the valve position of the control valve in the air line to keep the desired fuel/air ratio.

#### 5.5 CASCADE CONTROL SYSTEM

In a cascade control configuration we have one manipulated variable and more than one measurement. In the scheme there will be two controller's namely primary controller and secondary controller. The output of the primary controller is used to adjust the set point of a secondary controller, which in turn sends a signal to the final control element (may be control valve). The process output is fed back to the primary controller, and a signal from an intermediate stage of a process is fed back to the secondary controller. The block diagram of such a cascade control system is shown in figure.5.9

Two measurements are taken from the system and each used in its own control loop. The outer loop (primary controller) controller output is the set point of the inner loop (secondary controller). Thus, if the outer loop variable changes, the error signal that is input to the controller effects change in set point in inner loop. Even though the measured

value of the inner loop is not changed, the inner loop experiences an error signal and thus new output virtue of the set point change. Cascade control generally provides better control of the outer loop variable than is accomplished through the single variable system.

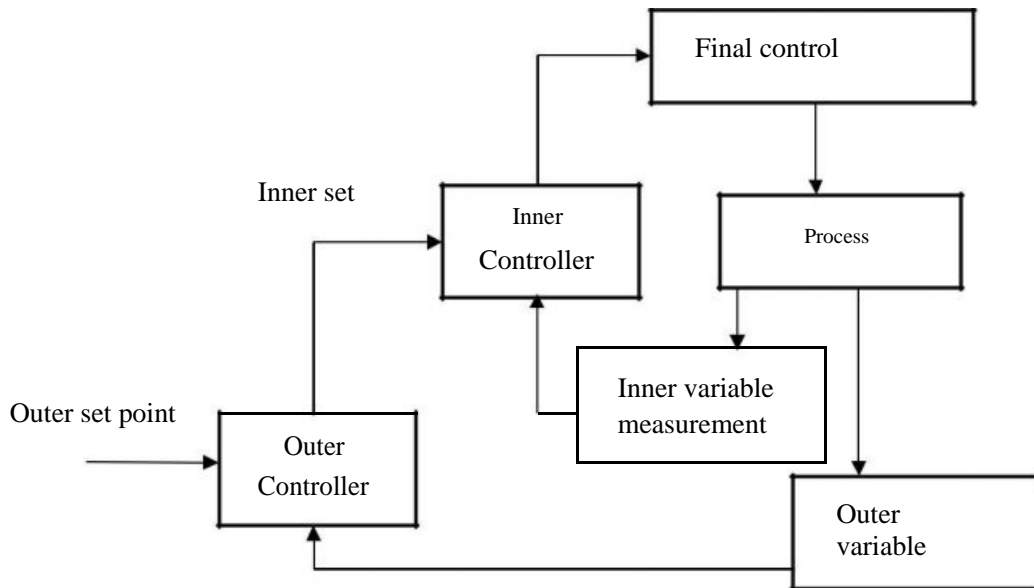

Fig 5 .9 Cascade Process Control System

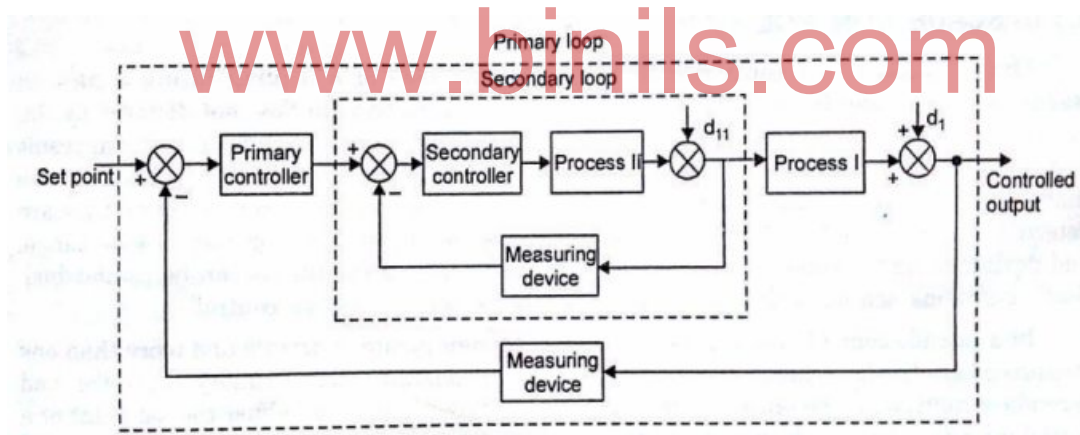

Fig 5 .10 Cascade Control

The systematic representation of a cascade control is shown in figure 5.10 which clearly demonstrates that the disturbances arising within in the secondary loop are corrected by the secondary controller before they can affect the value of the primary controller output. This important benefit has led to the extensive of cascade control in industrial (especially in chemical) processes. In chemical processes, flow rate control loops are almost always cascaded with other control loops.

### 5.5.1 CASCADE CONTROL OF HEAT EXCHANGER

1. A heat exchanger exchanges heat between two streams, heating one and cooling the other.

- Heat can be transferred between the same phases (liquid to liquid, gas to gas etc) or phase change can occur on either the process side (condenser, evaporator, reboiler etc) or the utility side (steam heater) of the heat exchanger.

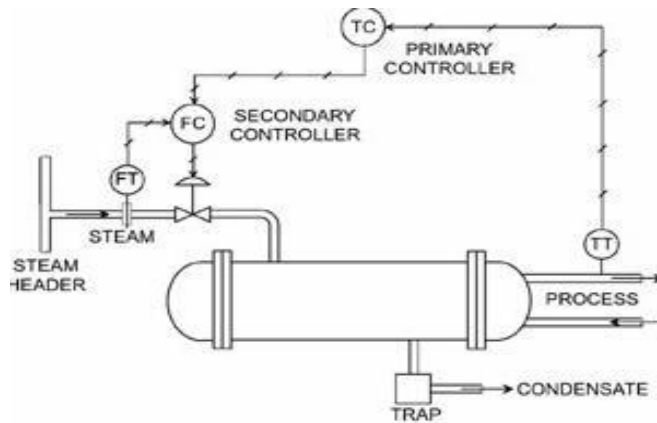

Fig 5.11 Cascade Control of heat exchanger

- The process outlet temperature of a heat exchanger is sensed. The temperature controller then adjusts the set point of the steam-flow controller to maintain the outlet temperature at set point.
- The temperature controller acts as a primary controller and flow controller acts as a secondary controller
- If temperature of fluid rises above the set point the temperature controller generates signal which acts as the set point to the flow controller.
- Flow controller closes the control valve that decreases the flow of heating liquid so as to get desired heating effect.
- Similarly if the heating fluid temperature falls below the desired value, the control valve opens with increases the flow of heating fluid so as to get the desired heating effect.

## 5.5.2 CASCADE CONTROL OF DISTILLATION COLUMN

### DISTILLATION COLUMN

- Distillation is defined as a process in which a liquid or vapour mixture of two or more substances is separated into its component fractions of desired purity by the application and removal of heat.
- The primary piece of distillation equipment is the main tower. It is also called as 'column' or 'fractionators'.
- The other equipment associated with the column is shown in figure. They include
  - Condenser
  - Reboiler
  - Interheater/Inter cooler
  - Feed preheater

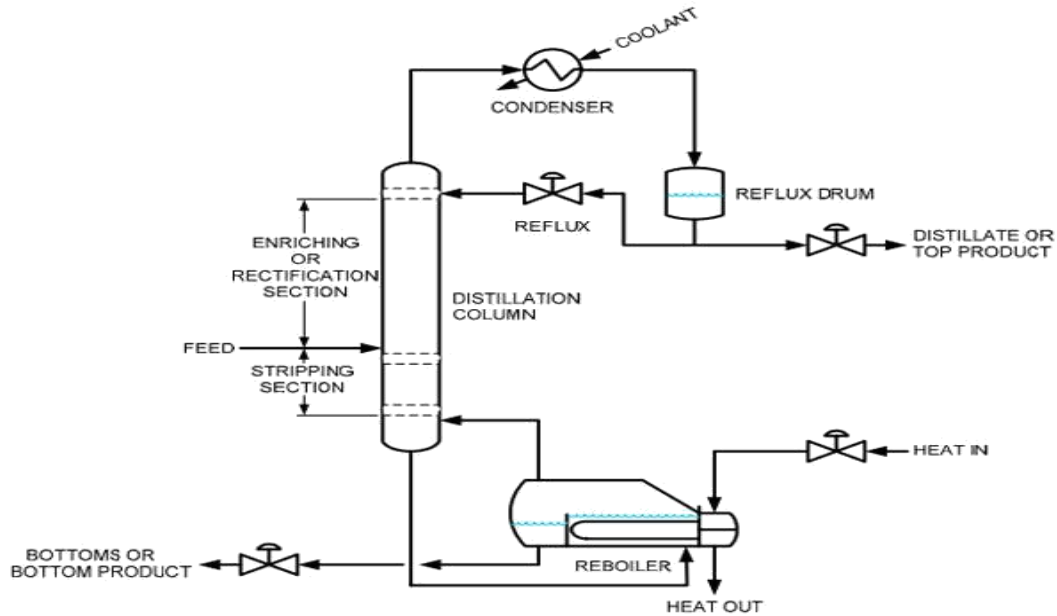

Fig 5 .12 Distillation column

### 5.5.3 CASCADE CONTROL OF DISTILLATION COLUMN

1. Reboiler: The liquid leaving the column bottom is heated in a reboiler. A reboiler is a special type of heat exchanger used to provide the heat necessary for distillation.
2. Part of the liquid is vapourised and returned into the column as boil-up. The remaining liquid is withdrawn as a bottom product.

www.binils.com

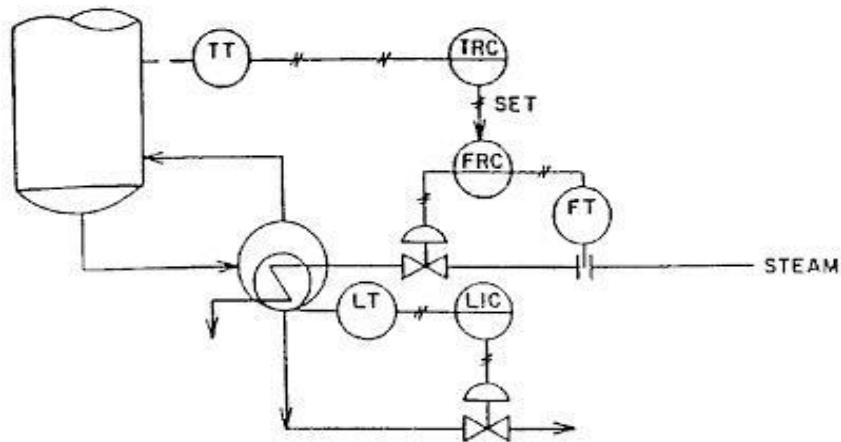

Fig 5 .13 Temperature Cascaded heat addition to the reboiler

3. Distillation separates materials according to their difference in vapour pressure and vapour pressure is a temperature- controlled function, temperature measurement has historically been used to indicate composition.
4. When composition of the bottom product is important it is desirable to maintain a constant temperature in the lower section.
5. This can be done by letting the temperature measurement manipulate the reboiler steam supply by resetting the steam flow controller set point as shown in the figure 5.13

6. It is a cascade control system with TRC as master controller and FRC as slave controller.
7. Bottoms product output line is provided with a control valve which will be operated with the level signal. That means the output is regulated maintaining the bottom level constant.

## 5.6 DIRECT DIGITAL CONTROL (DDC)

In the past computer was not directly connected to the process but used for supervision of analog controllers. The emergence of economical and fast microprocessor has made analog controllers to be replaced by digital computers as the same functions can be performed by them in more efficient and cost effective way.

Direct digital control means the computer directly controlled the process

### 5.6.1 DDC STRUCTURE

The DDC directly interface to the process for data acquisition and control purpose. Therefore DDC should have

1. Necessary hard ware for directly interfacing and reading the data from process.(Eg:-Opto isolator, Signal conditioner ,ADC)
2. Memory and arithmetic capability to execute P, PI, and PID control strategy.
3. Necessary hardware to control the process(Eg:- DAC, I to P converter)

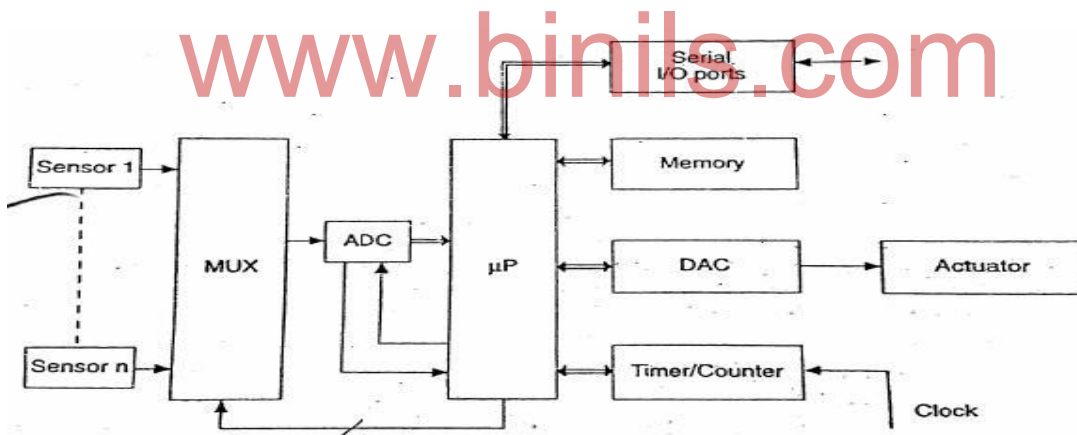

Fig 5 .14 DDC Structure

4. The process variable is sensed through sensors.
5. The multiplexer acts like a switch under microprocessor control. It switches at its output the analog signal from sensor/transmitter.
6. The analog to digital converter converts the analog signal to digital value.
7. The microprocessor performs the following tasks.
  - a. It reads the various process variables from different transmitters through multiplexer and ADC.
  - b. It determines the error for each control loop and executes control Strategy for each loop.
  - c. It outputs the correction valve to control valve through DAC.



8. The digital control signal from micro processor is converted in analog signal through DAC and it is given to actuator to control the valve.
9. DDC also called loop control, the functions of comparator, controller, limiting and other safeguarding operations are provided by the digital computer itself. Special control algorithm is prepared in the form of computer program (a software).

### 5.6.2 DIRECT DIGITAL CONTROL (DDC) OF SINGLE LOOP

1. Figure shows the hard ware elements of a single loop control system using digital computer.
2. The measurement signal from the sensor or transducer is sampled at prespecified intervals of time using a sample sampler.

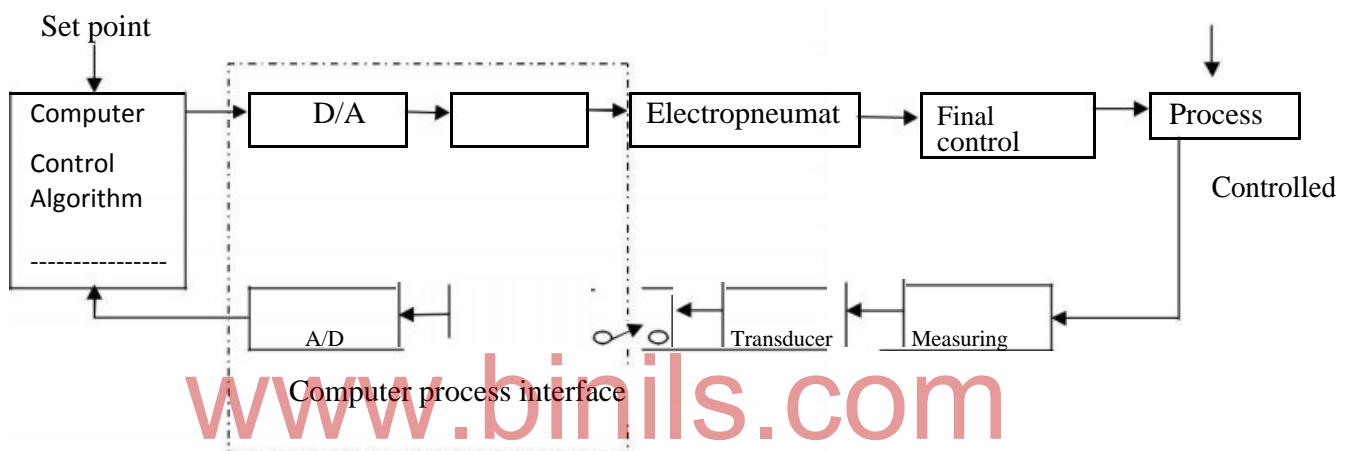

Fig 5 .15 Hardware components of digital computer single control loop

3. Thus it is converted from a continuous to a discrete time signal. This in turn is converted from analog to digital by an A/D converter and enters the computer.
4. The software of the control program, which resides in the memory and is executed by the computer whenever it is called.
5. The control commands produced by the control program are digital and discrete-time signals.
6. They are first converted to analog by a D/A converter and then to continuous-time signals by sample hold elements before they actuate the final control elements.

### 5.6.3 DIRECT DIGITAL CONTROL (DDC) OF MULTIPLE LOOP CONTROL

1. A digital computer can be used to control simultaneously several outputs.
2. Instead of using one A/D converter for every measured variable, we employ a single A/D converter which serves all measured variables sequentially through a multiplexer.
3. A multiplexer can also be used to obtain several outputs from a single D/A converter.
4. The control program is now composed of several subprograms, each one used to control a different loop.

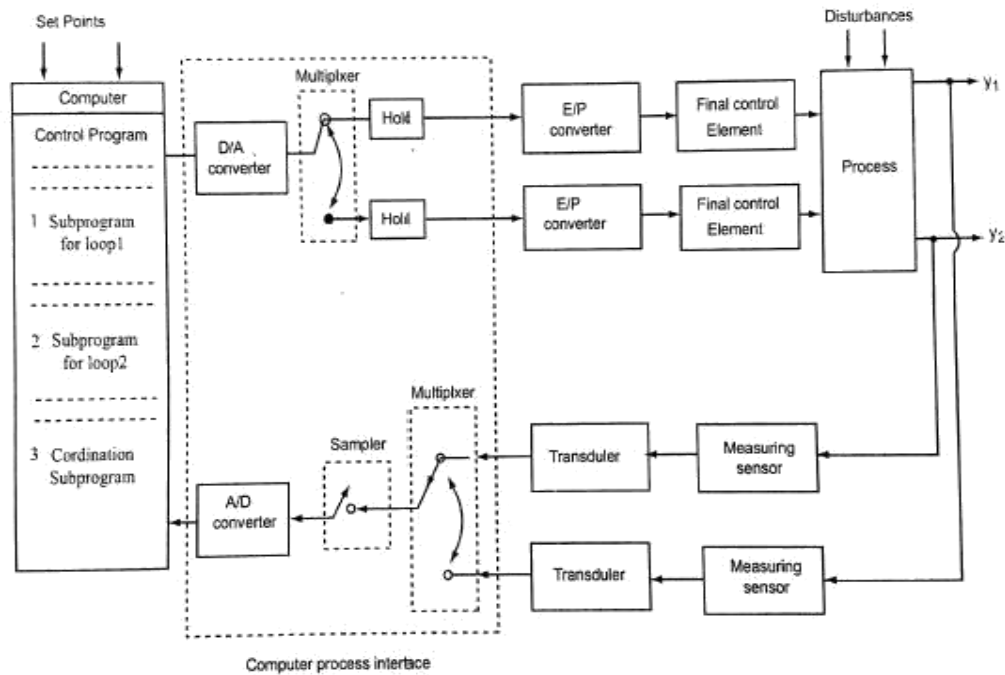

Fig 5 .16 Digital computer used in two distinct control loops

5. Figure shows the use of a single computer (CPU) to control outputs. When a digital computer has assumed all control actions of a conventional controllers.
6. Rapid technological developments in digital computing systems coupled with significant reduction in their cost have had a profound effect on how chemical plants can and should be controlled.
7. Already large plants such as petroleum refineries, ethylene plants, ammonia plants and many others are under digital computer control.
8. The benefits have been substantial both in terms of operating cost and in terms of operational smoothness and safety

#### REVIEW QUESTIONS:

##### PART- A (2 marks)

1. Expand SISO&MIMO
2. What is a feed forward control system?
3. List the advantages of feed forward control system.
4. List the dis-advantages of feed forward control system.
5. What is a ratio control system?
6. List the any four applications of ratio control system
7. What is a cascade control system?
8. List the advantages of cascade control system.
9. What is a direct digital control?

10. Expand DDC .

**PART - B (3 marks)**

1. Draw the block diagram of feed forward control system.
2. Write short notes on heat exchanger.
3. Compare feed forward and feedback control system.
4. Draw the block diagram of ratio control system.
5. Draw the block diagram of cascade control system.
6. Write short notes on distillation column.
7. Draw the DDC Structure.
8. What is meant by a direct digital control of single loop?
9. Draw the block diagram of direct digital control of single loop.
10. What is meant by a direct digital control of multiple control loops?
11. Draw the block diagram of direct digital control of multiple control loops.

**PART - C (10 marks)**

1. With a neat block diagram explain the feed forward control system with heat exchanger.
2. With a neat block diagram explain the ratio control system with an example.
3. With a neat block diagram explain the cascade control system with heat exchanger.
4. With a neat block diagram explain the cascade control system with distillation column.
5. Explain the direct digital control of single loop and multiple control loops with neat diagram