

**GOVERNMENT OF TAMILNADU
DIRECTORATE OF TECHNICAL EDUCATION
CHENNAI – 600 025**

STATE PROJECT COORDINATION UNIT

Diploma in Instrumentation and Control Engineering

Course Code: 1042

M – Scheme

e-TEXTBOOK

on

MEASUREMENT OF PROCESS VARIABLES

for

IV Semester DICE

Convener for ICE Discipline:

Dr.S.Rajakumari,

Head of Department/ECE,

Dr.Dharmambal Govt. Polytechnic College for Women,
Taramani, Chennai - 600 113

Team Members for Measurement of Process Variables:

Mr.R.Sagaya Lourdu Delcause,

Lecturer (SG) / ICE,

420, Women's Polytechnic College,
Karaikal – 609 605

Mr.R.Devarajapandian,

Lecturer / ICE,

178, Bharathiyar Centenary Memorial Govt Women's Polytechnic College,
Ettayapuram – 628902

Mr.M.Sundaram,

Lecturer / ICE,

280, ADJ Dharmambal Polytechnic College,
Nagapattinam – 611 001

Validated By:

Mr. S.Sridhar,

Lecturer (SG) / ICE,

224-Annamalai Polytechnic College,
Chettinad – 630 102

DETAILED SYLLABUS

34243-MEASUREMENT OF PROCESS VARIABLES (M-Scheme)

MEASUREMENT OF TEMPERATURE

Pages 1 - 17

Mechanical methods - Pressure spring – Liquid – Gas - Vapour in Glass - Liquid in Steel – Thermometers, Bimetallic thermometer - construction, working, range, advantages, disadvantages and applications of above.

Electrical methods – Thermocouples - Cold junction compensation - Lead wire compensation - Thermoelectric laws - Series and Parallel combination – Thermopile - Bolometer – Measurement of output of thermocouples using Potentiometer and Milli-voltmeter – RTD - 3 wire and 4 wire – Thermistors, construction, working, range, advantages, disadvantages and applications of above.

High temperature measurement - Non contact methods - Total radiation pyrometer – Selective radiation pyrometer - Photo electric pyrometer - Optical pyrometer - Temperature transmitter.

UNIT II:- MEASUREMENT OF PRESSURE

Pages 18 - 33

Types and units of pressure - Mechanical methods – Manometers (all types) – Elastic elements – Bellows – Diaphragms - Bourdon tube.

Electrical methods – Pressure measurement using Strain gauge, Capacitive transducer, LVDT and Piezo-electric transducer – Construction, working, range, advantages, disadvantages and applications of above.

Pressure calibration - Dead weight tester; Transmitter - Differential pressure transmitter.

Data transmission theory and Telemetry system – General telemetry system – Radio frequency telemetry system – Brief theory about modulation and demodulation.

UNIT III:- MEASUREMENT OF FLOW (MECHANICAL)

Pages 34 - 46

Bernoulli's theorem - Continuity equation – Reynold's number - Types of flow - Inferential flow meters - Differential pressure type meters - Orifice plates - Venturi tube - Flow Nozzle - Dall tube - Pitot tube (No derivation) - Positive displacement type meters - Nutating type meter – Oscillation piston type – Construction, principle, working, advantages and disadvantages of the above.

UNIT IV :- MEASUREMENT OF FLOW (ELECTRICAL)

Pages 47 - 59

Electromagnetic flow meter - Ultrasonic flow meter - Doppler and Transit time method – Swirl meter - Vortex Shedding meter - Cross correlation meter - Thermal mass flow meter - Solid flow measurement using conveyor belt method - Turbine flow meter - Target flow meter - Hot wire anemometer – Construction, Principle, working, advantages and disadvantages of the above.

UNIT V :- MEASUREMENT OF LEVEL, HUMIDITY AND MOISTURE

Pages 60 - 74

Level - Measurement of differential pressure to indicate level, Measuring by the movement of float, Electrical methods - Change in conductance - Change in capacitance - Radiation method – Sight glass - Solid level - Bin type and diaphragm type - Level in open and closed vessel.

Moisture - Moisture in Granular material, Solid penetrable material, Paper and textiles

Humidity – Measurement of humidity – Absolute humidity – Relative humidity – Psychrometer – Hair hygrometer.

Density and specific gravity – Definition – Measurement using weighing tube type – Construction, principle, working, advantages and disadvantages of the above.

TEXT BOOK:-

1. A.K.Sawhney, A course in Electrical & Electronic measurements and instrumentation, Dhanpat Rai & Co, Reprint 2010.

REFERENCE BOOKS:-

1. S.K.Singh, Industrial Instrumentation and Control, Tata McGRaw Hill 2005.
2. D.Patranabis, Principles of Industrial Instrumentation, Tata McGraw Hill 2005.
3. Arun K Ghosh, Introduction to Measurements and Instrumentation, 3rd edition, PHI Learning Pvt Ltd.
4. V.Pugazhendhi, Electronic Measurement and Instrumentation, RBA Publishers

www.binils.com

UNIT I MEASUREMENT OF TEMPERATURE

The temperature of a substance is a measure of the hotness (or) coldness of that substance. The most commonly used temperature units are **degree Centigrade (°C)** and **degree Fahrenheit (°F)**.

MECHANICAL METHODS

1. CHANGE IN VOLUME OF LIQUID (OR) EXPANSION OF LIQUIDS: -

This can be classified as:

1. Liquid in Glass Thermometer
2. Liquid in Metal Thermometer

1.1) LIQUID IN GLASS THERMOMETER: -

PRINCIPLE:- It is the simplest temperature-measuring device widely used in Industries and laboratories. Its operation is based on **liquid expansion as the temperature rises**. The expansion causes the liquid to rise in the capillary and indicates the temperature.

CONSTRUCTION & WORKING: -

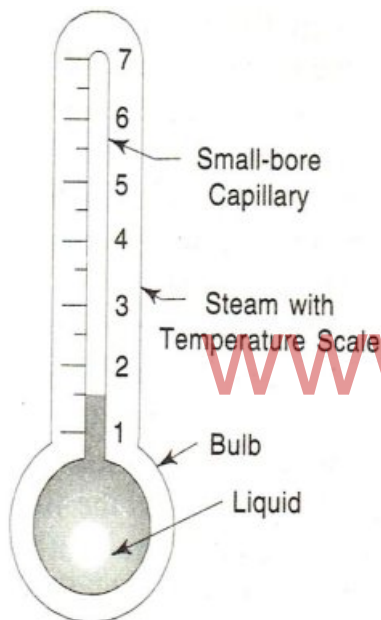

It consists of a small-bore glass tube and with a small glass bulb at its lower end. The liquid that fills the bulb and part of the capillary tube is usually **Mercury**. As heat is transferred mercury expands, pushing the column of mercury higher in the capillary, which indicates the temperature.

Range: - It is used in the temperature range of **minus 120°C to plus 320°C**.

When Mercury is used as liquid, it freezes at minus 39°C. Hence for measuring very low temperature, **alcohol** is used as the liquid.

For measuring higher temperatures, the thermometer glass stem above the mercury is charged by Nitrogen at a Pressure 30 to 300 Psi. This helps in preventing the mercury from Evaporating or Boiling. Even with Nitrogen, Liquid in Glass thermometer is limited to temperature below 600°C. Temperatures higher than 600°C can affect the glass and cause permanent changes in the volume of the bulb and affects the accuracy of the instrument.

Fig 1.1 Liquid in glass thermometer

LIMITATIONS OF LIQUID IN GLASS THERMOMETER: -

1. It cannot be used for Automatic Recording or Transmission of data.
2. Difficult to read.
3. Limits their use in Modern industries.
4. Due to ageing, there will be a change in size of the bulb, which introduces errors.

Applications: -

1. Open tank containing liquids.
2. Cooking kettles.
3. Molten Metal Baths.

1.2) LIQUID IN METAL (STEEL) THERMOMETER: -

The limitations of Liquid in Glass thermometers are overcome in this thermometer. In this mercury is used as the liquid and the metal is steel. Liquid in Metal thermometer works on exactly the same principle as Liquid in Glass thermometer. Here the Glass bulb is replaced by Steel bulb and the Glass capillary tube by Stainless steel.

Mercury is used as liquid in the system. As Mercury (Hg) in the system is not visible, a Bourdon tube is used to measure the change in its volume. The bulb, the capillary and the bourdon tube are completely filled with mercury.

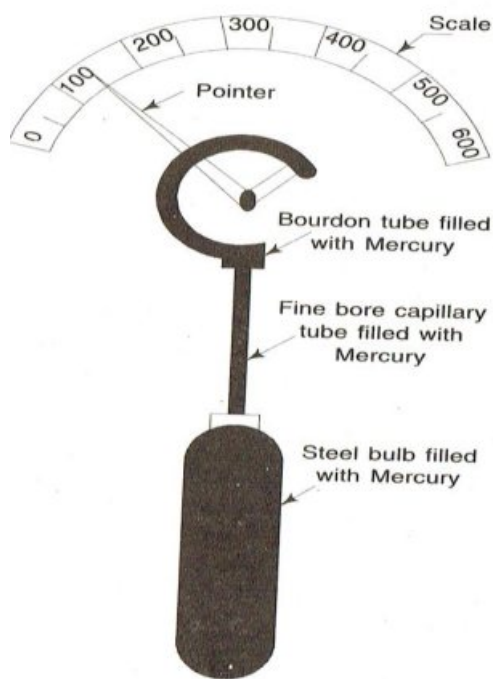

Fig 1.2 Mercury in Steel Thermometer

When the temperature rises, the mercury in the bulb expands more than the bulb, so that some mercury is driven through capillary tube into the Bourdon tube, causing the Bourdon tube to bend. One end of the Bourdon tube is fixed, while the movement of the other end is communicated to the pointer, which moves on a calibrated temperature scale. The thermometer bulb is placed in a protective pocket. The protective pocket is provided to protect the bulb from high pressure and to replace the bulb without shutting down the plant.

Some of the liquids used in Liquid in Metal Thermometers are **Mercury, Xylene, Alcohol and Ether.**

2. CHANGE IN PRESSURE OF GAS (OR) GAS THERMOMETER: -

PRINCIPLE: - The Principle of operation of Gas Thermometer is based on **Ideal Gas law.**

$$PV=RT$$

P = Absolute Pressure
 V = Volume
 T = Absolute Temperature
 R = Universal Gas constant

CONSTRUCTION & WORKING: -

Keeping Volume constant, if temperature is increased pressure will change (or) Keeping Pressure constant, if temperature is increased, volume will change. The changes are suitably calibrated in terms of temperature. A certain volume of inert gas is enclosed in a Capillary and Bourdon Tube, and the pressure indicated by a Bourdon tube may be calibrated in terms of temperature of bulb.

Nitrogen is the commonly used gas because it is **inert** and inexpensive and it gives a range of **minus 130°C to plus 540°C**. It does not react with the Steel bulb material.

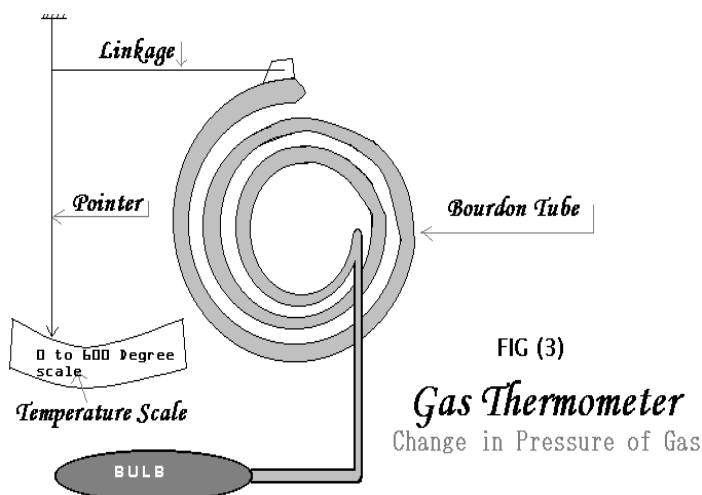

Fig 1.3 Gas Thermometer

ADVANTAGES: -

1. The gas in the bulb requires low thermal capacity than a similar quantity of liquid.
2. The response of a Gas thermometer to temperature change will be more rapid than that of a Liquid filled system with the bulb of same size and shape.

3. CHANGE IN VAPOUR PRESSURE (OR) VAPOUR PRESSURE THERMOMETER

Vapour Pressure Thermometer is also a Filled system thermometer. In this, the bulb is partially filled with liquid while Capillary and Bourdon Tubes are filled with Vapour. In this, some of the liquid vaporizes during operation. Various liquids used in Vapour pressure systems are **Argon, Methyl Chloride, Sulphur dioxide (So₂), Toluene, Ethyl Chloride (C₂H₅Cl).**

The liquid in Vapour Pressure Thermometer boils and vaporizes during operation that creates gas or vapour inside the capillary and Bourdon tube. A Vapour Pressure Thermometer converts the temperature information into pressure as gas thermometer, but it operates on different process.

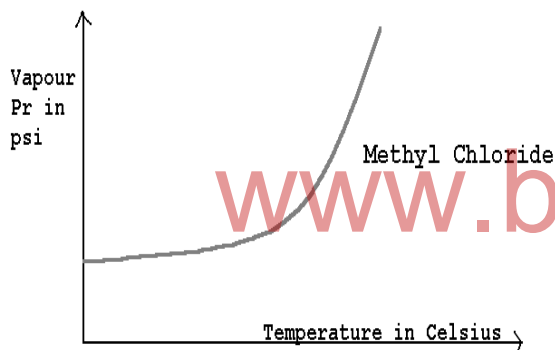

Fig 1.5 Vapour pressure curve for Methyl Chloride

4. EXPANSION OF SOLIDS (OR) BIMETALLIC THERMOMETER: -

PRINCIPLE: - The Principle is based on expansion of solids as the temperature rises. The expansion of solids to measure temperature is utilized by means of bimetallic strip. The two materials having different coefficient of expansion such as **Brass** and **Invar** are used. Brass 0.189×10^{-4} and Invar 0.009×10^{-4} .

CONSTRUCTION & WORKING: -

The two strips of metals are welded or riveted together. Whenever the welded strip is heated, the two metals will change its length in accordance to the individual rates of thermal expansion.

The two metals will expand to different length as the temperature rises. This forces the bimetallic strip to bend towards the side with low coefficient of thermal expansion. One end of the bimetallic strip is fixed, so it cannot be moved. The deflection at the other end is **square of the length of the metal strip, total**

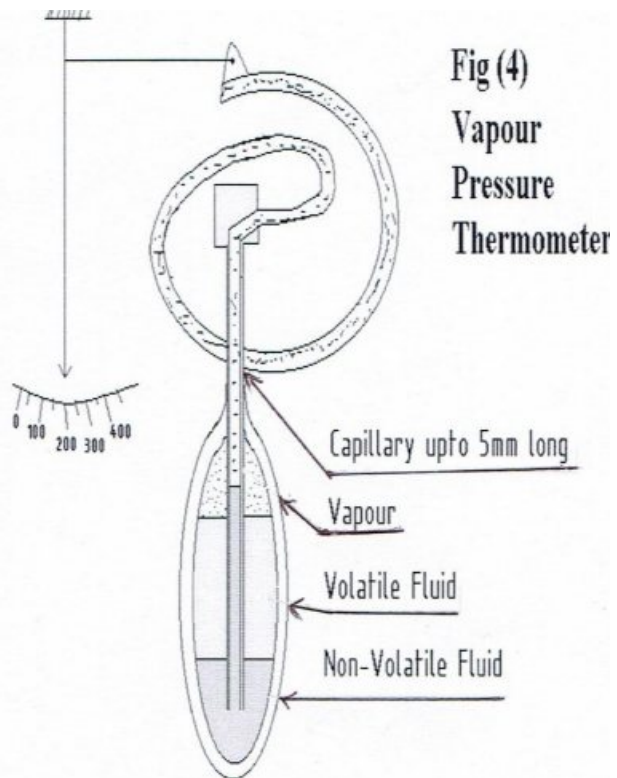
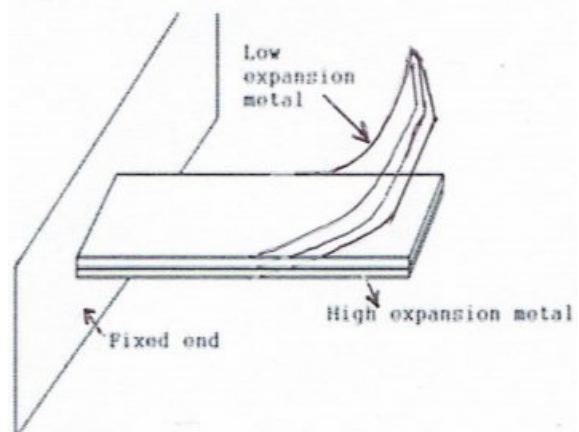

Fig 1.4 Vapour Pressure Thermometer

If a closed vessel is partially filled with liquid and boiled, then the space above the liquid will consist of evaporated vapour of the liquid at a pressure that depends on temperature. If the temperature also results in condensation of some of the vapour then the vapour pressure will decrease. Thus, the vapour pressure depends on the temperature. **Methyl Chloride** is often employed in such thermometer.

Fig 1.6 Bimetallic Thermometer



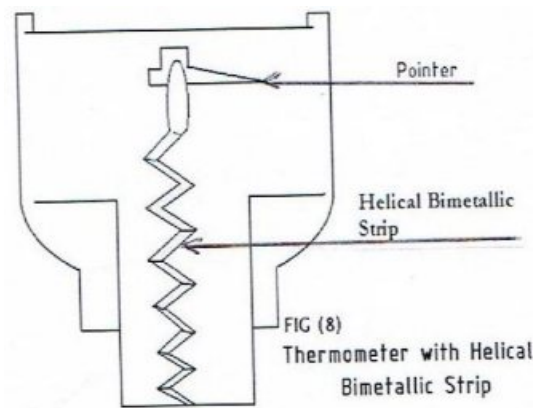
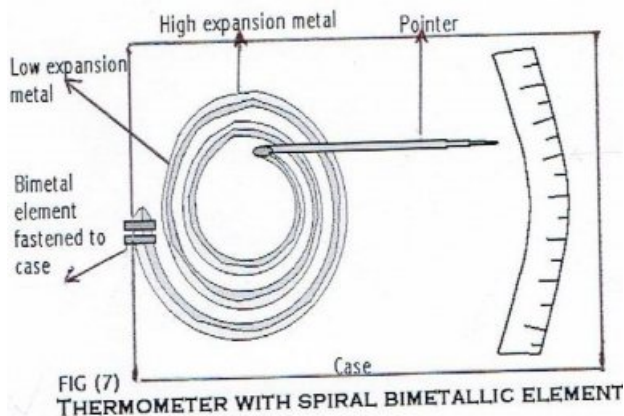

Fig 1.7 Bimetallic Thermometer with spiral strip **Fig 1.8 Bimetallic Thermometer with helical strip**
change in temperature and $1/\text{thickness}$ of the metal strip. The movement of the bimetallic strip is utilized to deflect the pointer over a calibrated scale.

The deflection of the strip is small if the strip is short and the deflection will be larger, if the strip is long. A larger strip can be contained in a small space if the strip is wound on a spiral or helix form. If the bimetallic element is wound in the form of a spiral, the spiral coil is tightened with increase in temperature.

ADVANTAGES:-

1. Low cost
2. Tough not easily broken.
3. Easily installed and maintained.
4. Good Accuracy.
5. Available in wide Temperature Range.

LIMITATIONS:-

1. Limited to local mounting.
2. Availability of Indication type only,
3. Possibility of recalibration due to rough handling.
4. Accuracy is not as high as Glass stem thermometer.

ELECTRICAL METHODS

There are two main electrical methods used for measuring temperature. They are

1. Thermo-resistive type (ie) Variable Resistance Transducers like **RTD** and **Thermistor**
2. Thermo-electric type (ie) emf generating transducer like **Thermocouple**.

1. THERMISTORS: -

The word Thermistors derived from **Thermally Sensitive Resistors**. Usually, Thermistors have **negative temperature coefficient of Resistance**.

PRINCIPLE:- As the temperature increases, the resistance of Thermistor decreases and vice versa.

Fig 1.9 Types of Thermistors

MATERIALS USED: - Thermistors are semiconductors made from a specific mixture of pure oxides such as **Nickel, Manganese, Magnesium, Copper, Cobalt, Iron** etc.

TYPES OF THERMISTORS: -

Thermistors are available in different types. They are

- | | |
|---------------|-----------------|
| (a) Bead type | (c) Washer type |
| (b) Disc type | (d) Rod type |

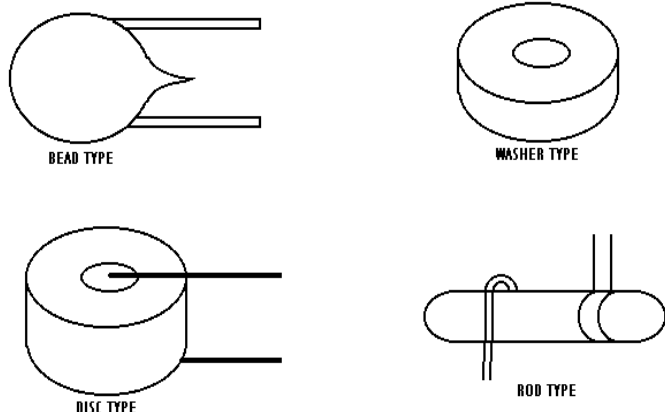

THERMISTOR WHEATSTONE BRIDGE CIRCUIT: -

Generally, the Thermistor is placed in one leg of a Wheatstone bridge circuit. At balance condition, when there is no change in temperature, the galvanometer (G) indicates zero. As the temperature increases (or) decreases, the resistance of the Thermistor also increases (or) decreases due to which the Wheatstone bridge circuit becomes unbalanced. The deflection of the galvanometer (G) can be calibrated on the temperature scale.

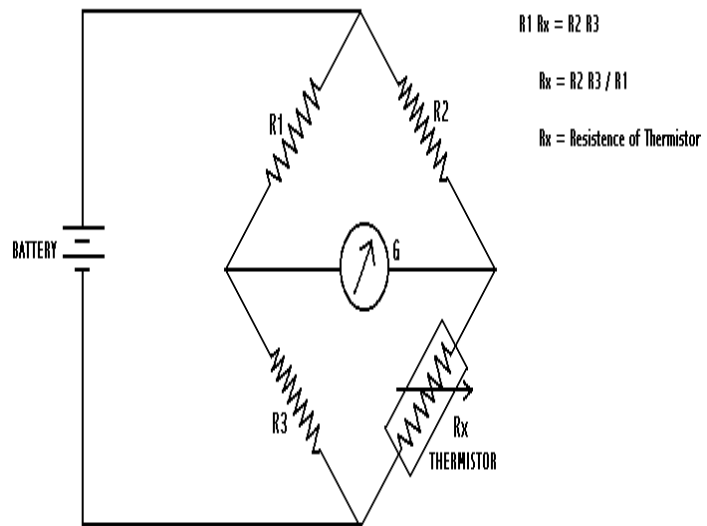

Fig 1.10 Thermistor Wheatstone bridge circuit

For very accurate temperature measurements, a differential bridge circuit is used in which two Thermistors are connected in two legs of the Wheatstone bridge. The unbalance is determined by the difference in resistance caused by the temperature of two Thermistors.

CHARACTERISTICS: -

The Thermistors follow the following characteristics $R = ae^{b/T}$

a & b are constant

R = Resistance of Thermistors at Absolute temperature (T).

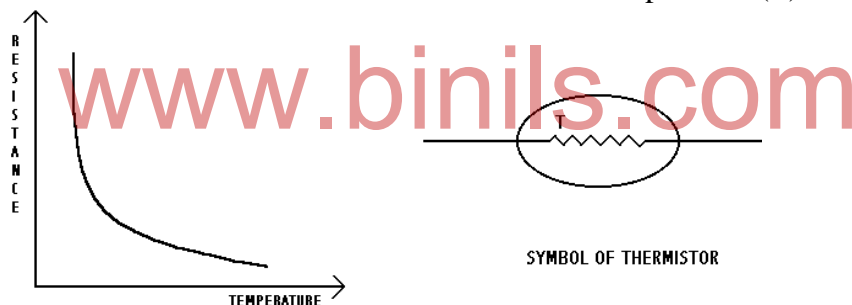

Fig 1.11 Characteristics of Thermistors

ADVANTAGES: -

1. Small size and Fast response.
2. Suitability of narrow spans.
3. Low cost.
4. Resistance is a function of Absolute temp, so cold junction compensation is not required.
5. Compatible to various electrical read out

LIMITATIONS:

1. Non-Linear Characteristic curve.
2. Unsuitable for wide temperature spans.
3. Being limited to process applications.
4. Power supply required.
5. Need for a Wheatstone Bridge circuit..

2. RESISTANCE TEMPERATURE DETECTOR (RTD): -

PRINCIPLE: - The resistance of certain metals changes with temperature change.

MATERIAL USED: - Platinum, Nickel and Copper are generally used in RTDs.

RANGE: - RTDs are used in the range of -200 to 650°C

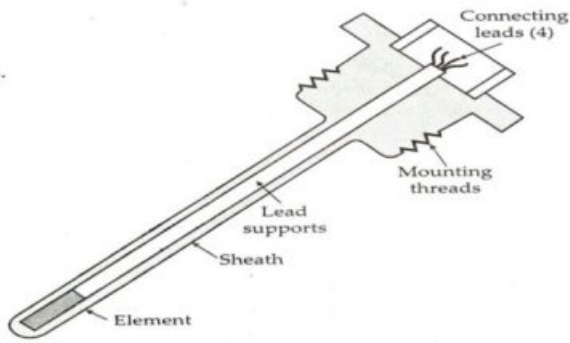

Fig 1.12 Industrial RTD

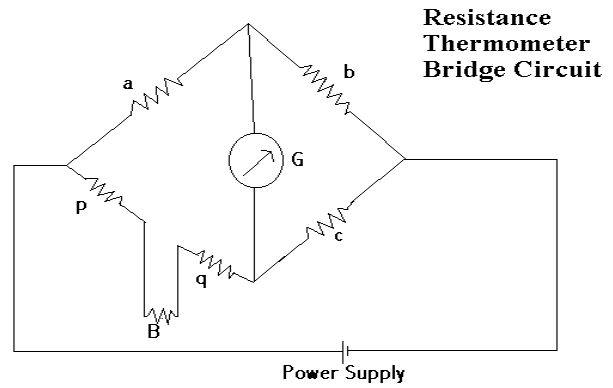

Fig 1.13 RTD Wheatstone bridge circuit

RTD WHEATSTONE BRIDGE CIRCUIT: -

The changes in resistance caused by the changes in temperature are detected by Wheatstone bridge circuit. The temperature sensing element inside a well along with the Bridge circuit forms the temperature measuring system. The sensing element (B) is made up of a material having high temperature coefficient of resistance. In the Fig Shown a, b, c are made up of material whose resistance is practically constant, under temperature change. When the bridge is balanced,

$$ac = b(p + B + q)$$

Now if the resistance of (B) changes, the bridge gets unbalanced and the Galvanometer shows deflection, and it can be calibrated on a suitable temperature scale.

RTD CHARACTERISTICS:-

The Characteristics of RTD represents the **Positive temperature Coefficient of resistance**.

www.binils.com

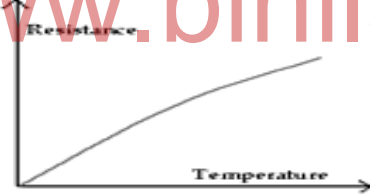

Fig 1.14 Characteristics of RTD

2-WIRE SYSTEM: -

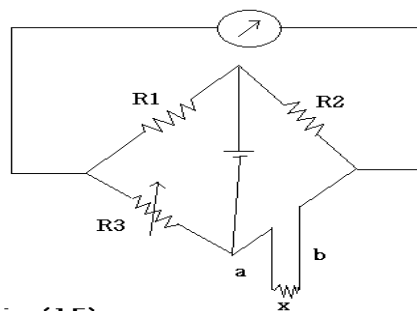

Fig 1.15 Two Wire RTD System [R3 = a+x+b]

Two wire systems are used only when lead wire resistance can be kept at minimum. Moreover, it can be used when moderate accuracy is required.

3-WIRE SYSTEM:-

In 3-wire system, two leads are connected at close to the resistance element at a common node. Third lead is connected to opposite side of resistance leg of the element. Resistance of lead (a) is added to bridge arm (R3). Resistance of lead (b) is added to bridge arm (x). From the Fig. $R1(b+x+c) = R2(R3+a+c)$

[i.e., $R1 = R2$]

$$b+x = R_3+a$$

If $a = b$ (lead resistance equal)

$$x=R_3$$

Special matching techniques must be used when distance between Bridge circuit and measuring equipment is relatively large

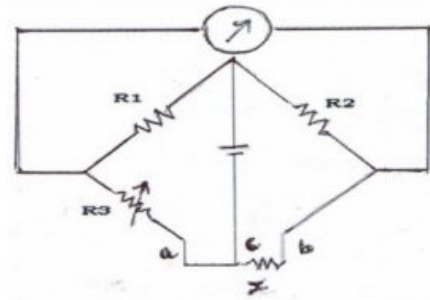

Fig 1.16 Three wire RTD system

4 WIRE SYSTEM:-

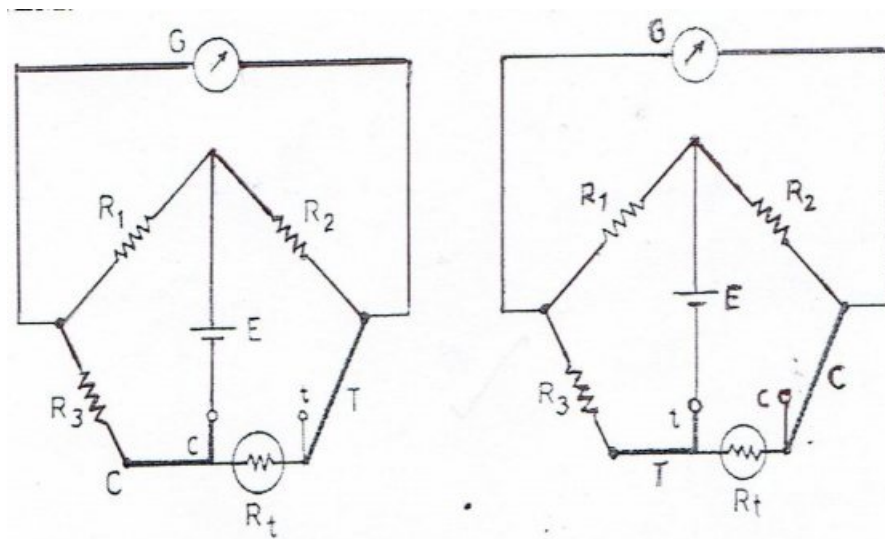

Fig 1.17 Four wire RTD system

The 4 Wire systems are used when the highest degree of accuracy is required. Such a system with Platinum resistance thermometer is employed as laboratory standard for calibration purposes. In this method, two circuit arrangements are used. Both the arrangements are required for the measurement purposes. First a measurement is made using circuit of Fig (a) and then the second reading is taken by using circuit of Fig (b). The average of the two readings is taken to give the correct result.

From Fig (a), $R_a + C = R_t + T$

From Fig (b), $R_b + T = R_t + C$

From the above eqns, $R_t = \frac{(R_a+R_b)}{2}$

This method is used when high accuracy is required because it is time consuming and inconvenient. Two separate leads are connected to each end of the resistance winding. They are leads C and c on one side and T and t on the other side.

INDUSTRY STANDARDS: -

1. **PT-50:-** At 0^0C , Resistance is 50Ω
2. **PT-100:-** At 0^0c , Resistance is 100Ω

ADVANTAGES: -

1. Most stable
2. More accurate
3. More linear than thermocouple
4. Can be used as **Duplex RTDs**
5. Accuracy of the measuring circuit can be checked by substituting a Standard resistor.
6. Best suited for remote Industries.
7. Intrinsic safe circuit can be employed.

LIMITATIONS: -

1. Expensive
2. Power supply is required
3. Need for a Wheatstone Bridge circuit.

3. THERMOCOUPLE:-

PRINCIPLE: - The Principle of thermocouple is based on **Seebeck effect**. It states that when two dissimilar metals joined at both ends and one junction is made hot and the other cold, an emf is generated. The emf produced is proportional to the difference in temperature of the two junctions. The hot junction forms the sensor end and the cold junction can be connected to a milli voltmeter.

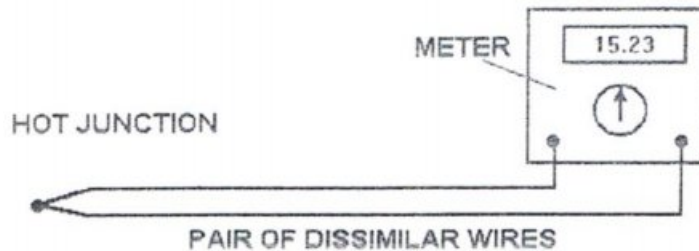

Fig 1.18 Seebeck effect

CONSTRUCTION: -

A pair of two dissimilar metals forms a thermocouple. The metals can be **Twisted, Screwed, Clamped** (or) **Welded** together. In some cases the Thermocouple is sheathed in a protective covering or even sealed in glass to protect the unit from a hostile environment. They are usually placed inside Protective Wells so that it can be easily removed (or) replaced without any interruption during the shutdown of the plant. Protective Wells are made of Stainless Steel. The size of the Thermocouple wire is determined by the application and can range from #10 wire in rugged environment to #30 AWG wires (or) 0.02 mm micro wire in refined biological measurements of temperature.

TYPES OF THERMOCOUPLES: -

Types	Materials	Range
J	Iron - Constantan	0°C to 800°C
K	Chromel - Alumel	0°C to 1200°C
T	Copper - Constantan	-199°C to 250°C
E	Chromel - Constantan	0°C to 600°C
R	87% Platinum + 13% Rhodium - Platinum	0°C to 1600°C
S	90% Platinum + 10% Rhodium - Platinum	0°C to 1600°C

3.1) COLD JUNCTION COMPENSATION: -A factor which is very important in the usage of thermocouple is known reference temperature at the Reference (Cold) Junction. When the Reference Junction is not held at 0°C, then the observed value must be corrected by adding it to a voltage that have resulted from a temperature difference equal to the amount by which the Reference Junction is above 0° C.

$$E = E_t + E_o$$

E = Total emf at temperature (T)
 Et= emf due to temp difference between measuring (hot) Junction and the Reference (Cold) Junction.

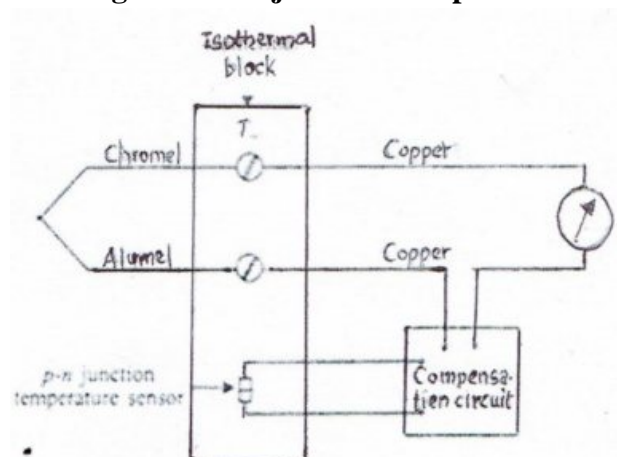

E_0 = emf due to temperature of the Reference Junction above 0°C .

Because of the nonlinear relationship between the emf and the temperature, it is important that temperature is determined by the above process, rather than converting an emf to temperature and then adding to ambient temperature.

Usually the Reference (Cold) Junction is kept at the ice point. But in the industrial instrumentation the technique shown in the Fig is widely used. In this arrangement, the PN Junction temperature sensor helps the compensation circuit to produce a compensation voltage, when the temperature of the Isothermal block (Reference Point) varies.

3.2) LEAD WIRE COMPENSATION: -

In many applications the Reference junction (Cold junction) is far away from the Measurement junction (Hot junction). The extension lead wires from the thermocouple to the meter are very long and are usually not at the same temperature throughout their length. This results in errors which can be reduced by using lead wires of same materials as the thermocouple wires.

Two of the most commonly used thermocouples, J type and T type normally use extension lead wires of the same material as thermocouple wires and therefore there are no errors. However the use of extension lead wires made of the same materials as the thermocouple wires may not be possible in many cases due to cost and other reasons. In such cases the materials for lead wires can be selected such that the relation between emf and temperature is same (or) almost same as thermocouple wires. These wires are called as **Compensating Leads**.

3.3) THERMOELECTRIC LAWS:-

1. A thermoelectric emf is produced when the junctions of two dissimilar homogenous metals are kept at different temperatures. This emf is not affected by temp gradients along the conductors.

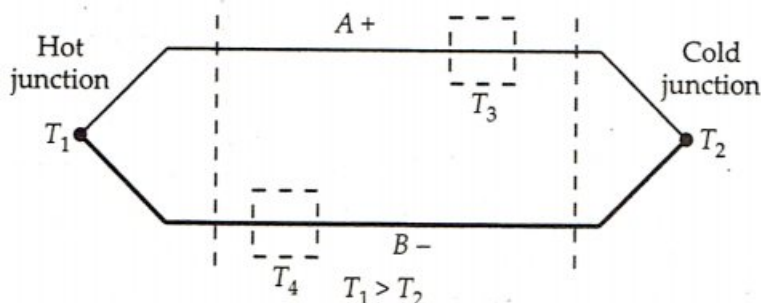

Fig 1.20 No emf is generated by temperature gradients in homogenous conductors

2. In a circuit containing of two dissimilar homogenous metals having the junctions at different temperatures, the emf developed will not be affected when a third homogenous metal is made as a part of the circuit, provided the temperature of the two junctions of the third metal are the same. This is called as **Law of Intermediate Metals**.

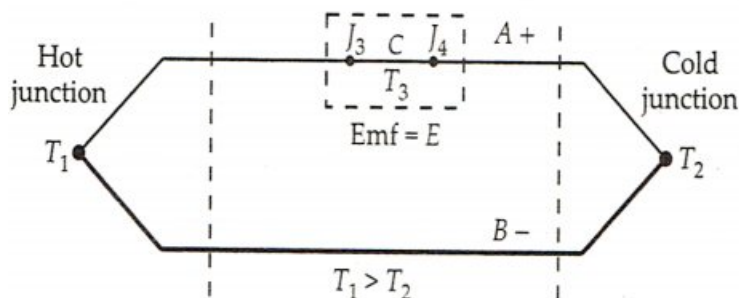
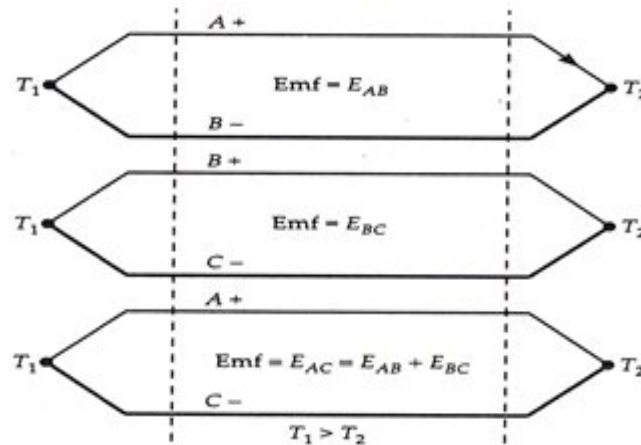
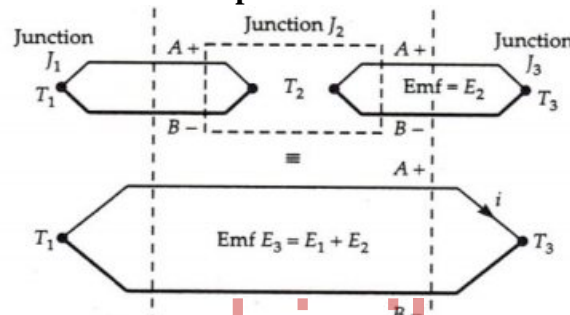

Fig 1.21 Introduction of a third metal does not affect the emf provided its two junctions are at the same temperature

3. The thermal emf's of two metals with respect to another is the algebraic sum of their individual with respect to a third metal.



4. The algebraic sum of thermal emf's produced between Junctions J1 and J2 and between J2 and J3 is equal to the emf E3, produced in a similar circuit between junctions J1 and J3. This is called as **Law of Intermediate Temperatures**.



5. The overall emf in a circuit containing two thermocouples is unaffected by the addition of more thermocouple at the same time.

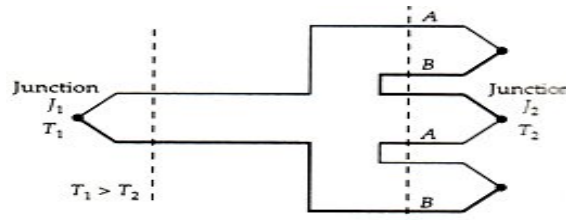

Fig 1.22 Additional thermocouples at junctions J1 and J2 not affect the net emf

3.4) SERIES AND PARALLEL COMBINATIONS OF THERMOCOUPLE: -

Even though a thermocouple is a device for measuring point temp but it is possible to measure **average temperature** by connecting the thermocouples either in Parallel (or) Series. The thermocouple may be connected either in series (or) in parallel depending upon the requirement.

(a) PARALLEL CONNECTIONS OF THERMOCOUPLES: -

Thermocouples can be connected in parallel to measure the average temperature .as shown in the Fig. The thermocouples used may not have equal resistances and to minimize the effect of unequal resistance in individual thermocouple and their lead wires, **Swamping resistor (Rs)** is used. The Swamping resistor is put in series with each thermocouple. The Swamping resistor prevents the current flow and the absence of these resistors results in measurement errors. The typical values of Swamping resistors vary from 500 – 2000 ohms.

For the Parallel connection shown in the Fig, the Total emf is $E = \frac{E_1 + E_2 + E_3}{3}$

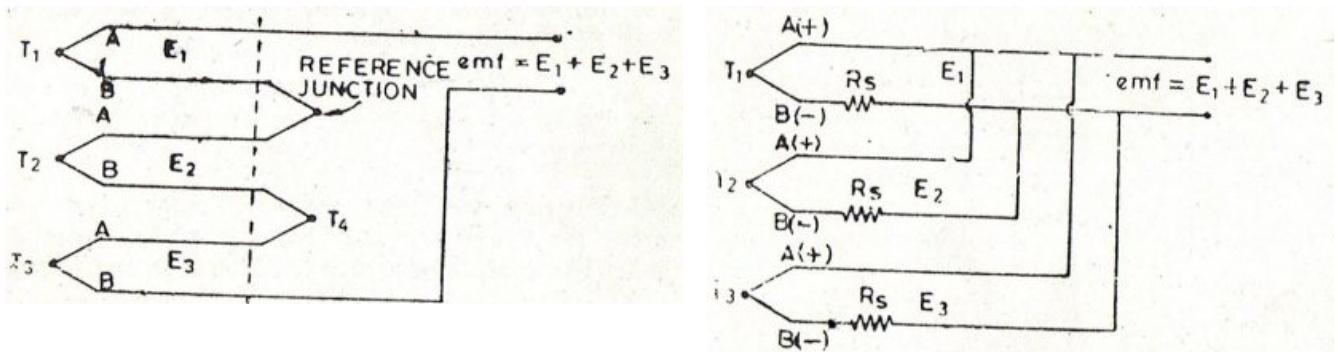

Fig 1.23 Parallel connections of Thermocouples for average temperature measurement

(b) SERIES CONNECTIONS OF THERMOCOUPLES: -

The Fig shows three thermocouples connected in series. In such arrangement, the Total emf is the sum of the emfs developed by individual thermocouples.

For the Series connection shown in the Fig, the Total emf is $E = E_1 + E_2 + E_3$. In case all the thermocouples are identical and they work under identical conditions, then the resultant emf is an n time the emf of an individual thermocouple. Such an arrangement is called as **Thermopile**.

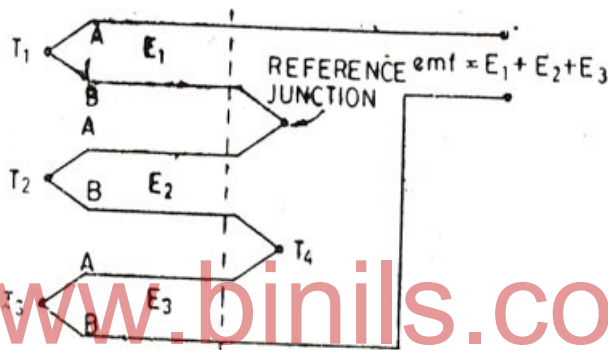
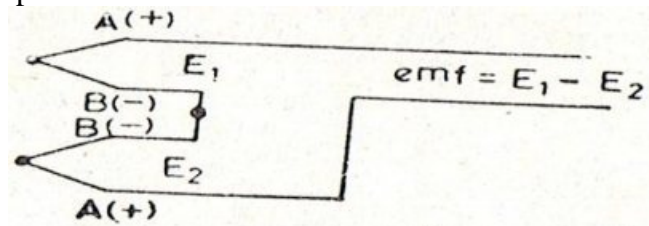

Fig 1.24 Series Thermocouples

The temperature difference can be measured easily by the connection of thermocouple in series but with reversed polarities. The net emf is $E = E_1 - E_2$



3.5) THERMOPILE: -

A Thermopile consists of a group of very small thermocouples connected in series and their emf's are additive. It is used in pyrometers as radiation receiving elements. In case all the thermocouples are identical and they work under identical conditions, $E = E_2 = E_3 = \dots E_n$ and the Total emf is n times the emf of an individual thermocouple. Such an arrangement is called as **Thermopile**. The Thermopile gives a very high sensitivity and also produces high output. It is well suited for the applications such as difference in temperatures of measuring and reference junction is small.

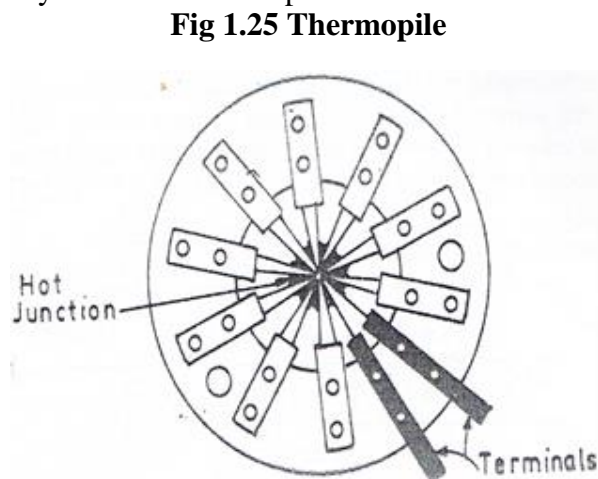

Fig 1.25 Thermopile

LIMITATIONS: -

1. It uses a large number of thermo junctions so that the probe size and mass are increased and results in slow response.
2. Errors are introduced because of heat loss due to radiation and results in low accuracy.

3.6) BOLOMETER: -

A Bolometer is a thermal device that changes its resistance with temperature. It is made up of thin ribbon (or) Platinum (or) Nickel depending upon the response required. The change in resistance is measured by a Wheatstone bridge circuit. The two thin strips are connected to the two arms of Wheatstone bridge circuit. One strip is exposed to the radiation and the other strip compensates for the change in the ambient temperature.

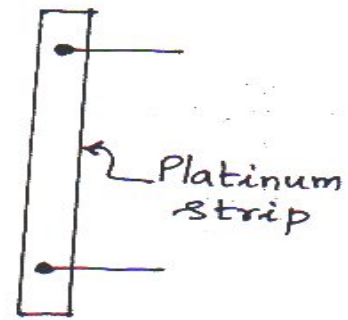

Fig 1.26 Bolometer

The two thin strips are connected to the two arms of Wheatstone bridge circuit. One strip is exposed to the radiation and the other strip compensates for the change in the ambient temperature.

The resistance of the Bolometer changes in response to the thermal radiation focused on it. The absorption of radiant thermal energy by the strip results in increase of resistance of the strip which is measured by the Wheatstone bridge circuit and calibrated in terms of temperature.

ADVANTAGES OF BOLOMETER: -

1. Fast response

LIMITATIONS OF BOLOMETER: -

1. Expensive to construct.
2. Less rugged than other detectors.

3.7) MEASURING INSTRUMENTS: -

(a) MILLI VOLT METER MEASUREMENT METHOD FOR THERMOCOUPLES: -

The simplest method of measuring the thermo emf and subsequently the temperature with the help of a dc mill voltmeter is shown in the Fig. Hence, the thermocouple is connected to a sensitive mill voltmeter across the cold junction. If the Resistance of the meter is (R_m) and Resistance of External circuit is (R_e) then the current is

$$i = \frac{E}{R_m + R_e}$$

In order to ensure sufficient current to deflect the movement, the resistance of the meter should be small since the sensitivity of the thermocouple is quite small and they produce an output voltage, which is a few $mV/100^\circ C$. If the instrument is giving a poor sensitivity, it will load the thermocouple and the indication in that case will not be accurate.

If the Installation of the instrument is remote, the drop between the hot junction and the extension leads result in errors. However, if the desired measurement is not to be very accurate then this method is useful. This method is also not expensive. For one particular thermocouple, the instrument can directly be graduated in terms of temperature.

Fig 1.27 Milli voltmeter method for Thermocouples

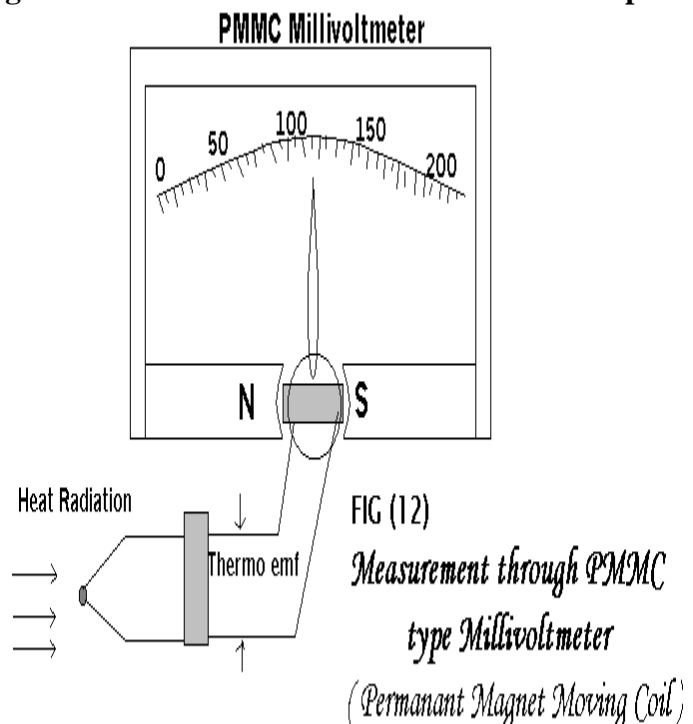

(b) POTENTIOMETER MEASUREMENT METHOD FOR THERMOCOUPLES: -

The most commonly used method for the measurement of temperature with thermocouple employs a DC Self-balancing Potentiometer. A circuit, which uses a Potentiometer for temperature measurement is shown in the figure. It is known that when a thermocouple is subjected to heat radiation, then thermo emf is developed across its ends as a function of temperature. Before using the thermo emf produced across the Potentiometer, it is standardized with the help of the Standard Cell.

CIRCUIT DESCRIPTION: -

The battery circuit is closed through the one-way key as shown in the circuit diagram. The two way key is made to close the circuit by bringing the standard cell across the potentiometer. The Galvanometer deflects and the key is slide across the Potentiometer wire to detect the null point. Let it be length (L1).

Now the two way key is made to close the circuit by bringing the thermo junction across the potentiometer. The key is slide again to detect a new null point. Let it be length (L2). It means that the Potential difference across length L2 is equal to thermo emf say e₂ volts.

(ie) $e_1/L_1 = e_2/L_2$ $e_1 = \text{emf of the Standard cell.}$

$e_2 = \text{thermo emf in volts}$

Then, $e_2 = \frac{e_1 \times L_2}{L_1}$

Since e₂ is a function of temperature, the Potentiometer can directly be calibrated to read the temperature and act as a thermometer.

Many types of automatic potentiometers have been developed both for automatic recording of temperature on chart recorders and for automatic process control.

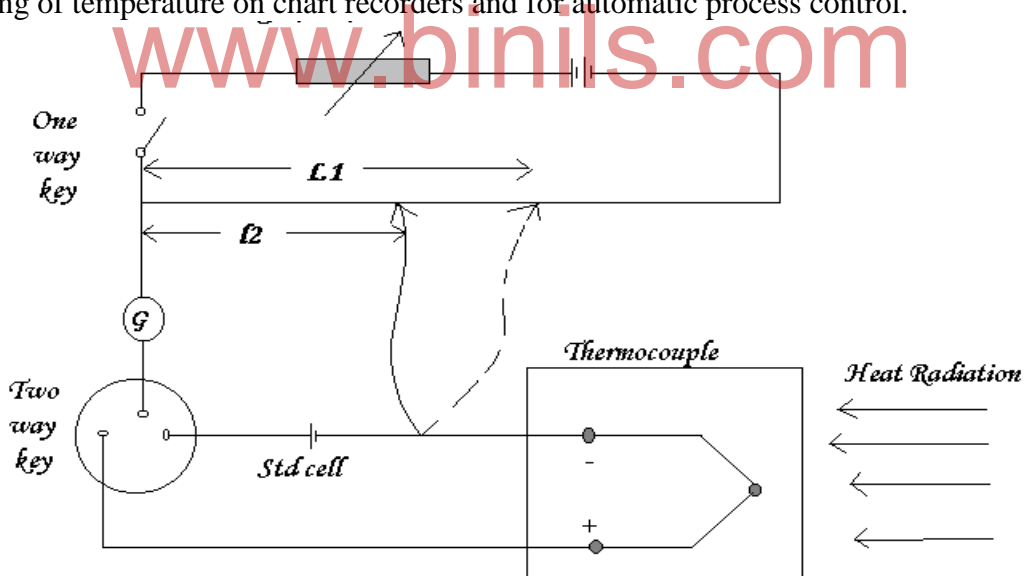

Fig 1.28 Circuit for Temperature measurement using Potentiometer

ADVANTAGES OF THERMOCOUPLE: -

1. Self powered (Active Transducer).
2. In expensive.
3. Simple and rugged construction.
4. Wide variety of design.
5. Wide temperature ranges from -270 to 2000 °C.
6. Long transmission distance possible.
7. High response speed compared to Filled system Thermometer.
8. No need for Wheatstone bridge circuit in the Secondary instrument.

LIMITATIONS OF THERMOCOUPLE: -

1. Non linear relationship between Temperature and Voltage (mV).
2. Low voltage.
3. Reference Junction (Cold Junction) is required.
4. Reference Junction temperature should be constant.
5. Chances of voltage pickup.
6. Maximum accuracy of measurement is obtained when the compensating wires are of same material as the thermocouple wires.

4. NON CONTACT METHODS:-

At higher temperatures (above 1400°C), temperature measuring instruments may melt due to direct physical contact. To solve this, a non-contact method of measurement of temperature is introduced. **Pyrometry** is a measurement technique of measuring temperature without physical contact.

When a body is heated, it emits thermal energy known as heat radiation. A blackbody is a very good absorber as well as emitter of such radiation. When the corrosive (or) liquid medium destroys thermocouple, RTD (or) Thermistor due to direct contact then **Pyrometers** can be used.

4.1) TOTAL RADIATION PYROMETER: -

Fig 1.29 Total radiation pyrometer

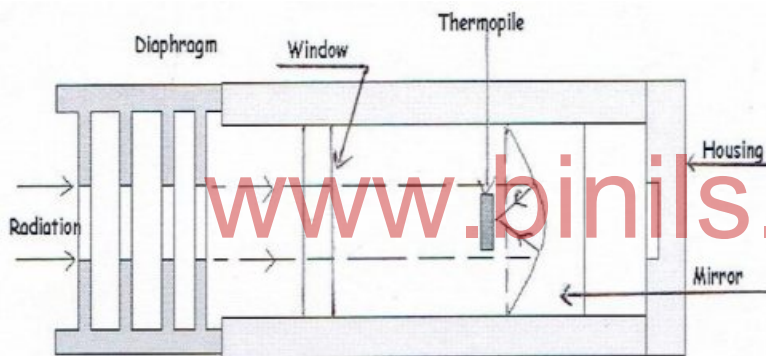

The Total Radiation Pyrometer receives all the radiation from a particular area of hot body and focuses it on a sensitive temperature transducer like Thermocouple (or) Thermopile. The term total radiation includes the Visible (light) and Invisible (Infrared) radiation.

The Total Radiation Pyrometer consists of a radiation receiving element and a measuring device to indicate the temperature directly. Here Diaphragm unit along with the mirror is used to focus the radiation on the detector.

Presence of any absorbing media between target and the transducer reduces the radiation received so that the Pyrometer reads low. Substances like dirt, smoke and gases absorb radiation. Moreover, the presence of heat sources like hot gases, high temperature particles and flames cause the pyrometer to read high.

Due to fourth power law, $Q \propto T^4$, the characteristic of Total Radiation Pyrometer are non-linear. The Output may be fed to a recorder (or) controller for controlling purpose.

Range: - It is used in the range of 1200°C to 3500°C .

4.2) OPTICAL PYROMETER: -

The method of operation is based on comparison of the Intensity (brightness) of the radiant energy emitted by the hot body with the radiation emitted by the source of known intensity. Here, the reference source of radiation is the Incandescence lamp filament. The brightness of the radiation emitted by the hot body whose temperature to be measured is matched with the brightness of the calibrated reference (lamp) whose temperature is known.

The filament is connected to one arm of the Wheatstone bridge circuit. The electrical resistance of the lamp filament varies in accordance with the temperature changes, while the resistances in other arms are constant. As the temperature of the filament is increased, the bridge is unbalanced. The amount of deflection in (G) is calibrated in terms of temperature.

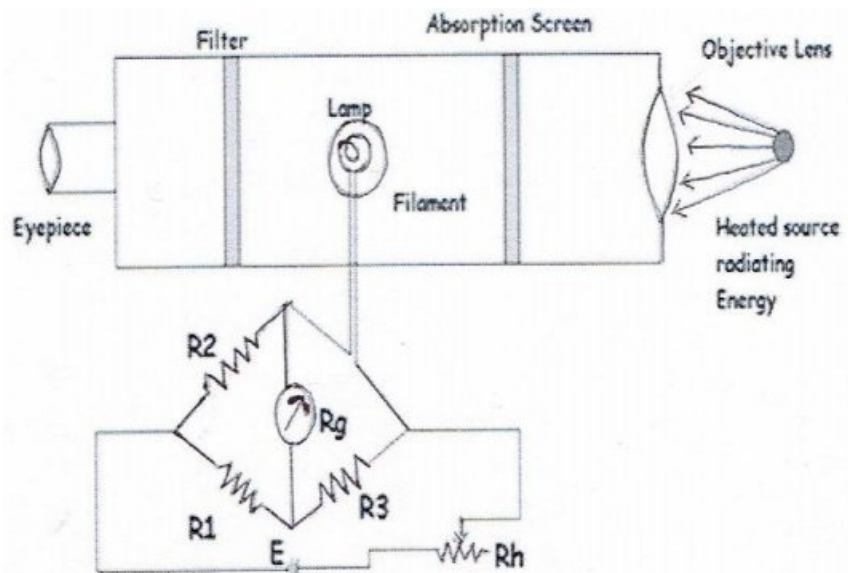

Fig 1.30 Optical Pyrometer

The hot object is viewed through the telescope, when the filament first appears as a dark line to the glowing background. By using the Rheostat, the temperature of the filament is increased until the visible radiation matches the hot object. At this stage, the temperature may be read off from the Galvanometer (G).

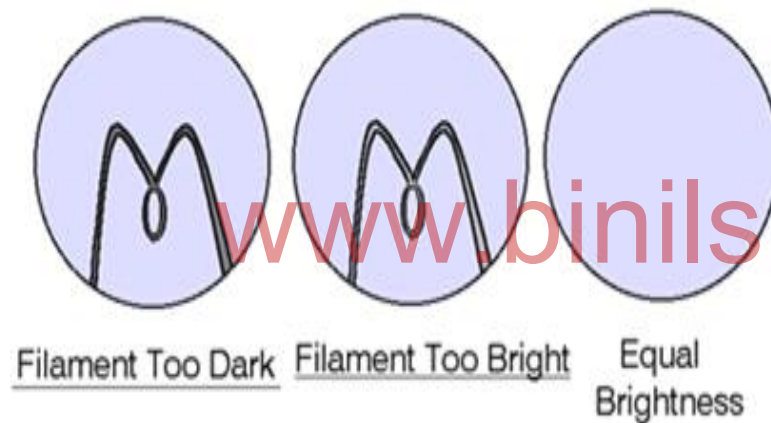

Fig 1.31 Optical pyrometer filament recognition

An Absorption Screen is used between the object and the filament that reduces the intensity of the radiation from the object, reading the filament. A monochromatic red screen is fitted to the eyepiece. Its function is to eliminate color difference between the filament and the hot body.

4.3) PHOTO ELECTRIC PYROMETER: -

Photoelectric transducers used for the detection of radiant energy are Photo emissive Cells, Photoconductive Cells and Photovoltaic Cells. The Output of the cells varies with the amount of radiant energy incident on them. In general, the Photo electric transducers are sensitive to given portions of the spectrum and therefore they are used with partial radiation. They are very rugged and have a very fast response.

Photo Conductive types exhibit an electrical resistance that changes with the incoming radiation. **Photo voltaic cells**, also called barrier photocells employ a photosensitive barrier of high resistance, deposited between two layers of conducting material. A Potential difference between these two layers is built up when the cell is exposed to radiation. Lead Sulphide Photoconductive cells are most frequently used.

Fig 1.32 Photo electric Pyrometer

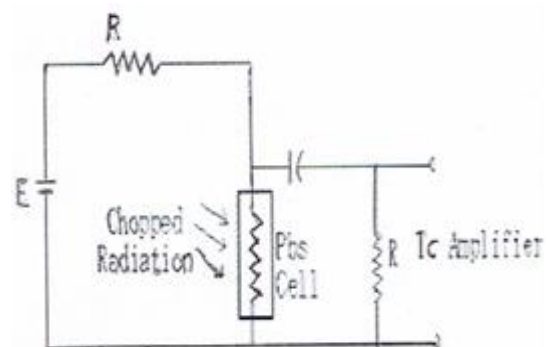

4.4) SELECTIVE RADIATION PYROMETER

Infra-red pyrometers are **partial** (or) **selective radiation pyrometers**. Infra-red energy is invisible to the human eye. There is a proportional increase in infra-red energy as the temperature of the radiating body increases. Above 550 °C, there is a proportional increase in the infra-red energy. This makes the infra-red pyrometry possible for indication (or) control by combining a suitable electronic circuitry. The infra-red spectrum ranges from 0.22 μm to 17 μm but the commonly used portion is 2 to 7 μm .

Various types of Photo-electric transducers are used as Infra-red transducers. The most successful transducer used for industrial applications is Photo voltaic cell. An outstanding feature of the pyrometers based on Photo voltaic cells is their high speed of response.

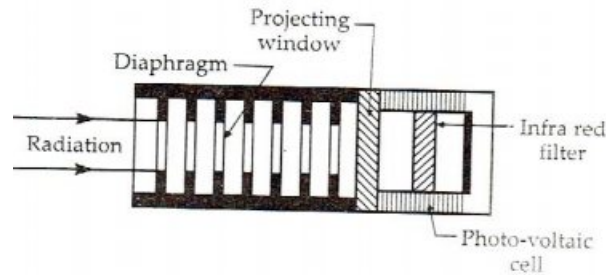

Fig 1.33 Infra-red Pyrometer

A infra-red pyrometer is shown in the fig. The cone of radiation passing to the photo voltaic cell is defined by the area of the first diaphragm. The protective window is made of thin glass and it is used to protect the photo voltaic cell and filter from physical damage. The filter is used to reduce the infra-red radiation passed to the photocell. This helps in protecting the photo voltaic cell from overheating.

The infra-red energy falling on the detector either changes the detector resistance in proportion to temperature as in the case of a thermistor (or) generates an emf in the detector, such as thermopile. The change in resistance (or) generated emf is then used for indication (or) for controlling a process.

5. TEMPERATURE TRANSMITTER: -

The emf generated by a thermocouple can be converted into standard 4-20 mA signal by using a transmitter. The Fig. shows a simplified Temperature Transmitter connection.

In the Fig, the temperature measurement circuit consists of a thermocouple which is connected directly to the Temperature Transmitter. The hot and cold junctions can be located wherever required to measure the temperature difference between the two junctions.

In most situations, monitoring the temperature rise of equipment is to ensure the safe operation. Temperature rise of a device is the operating temperature using ambient (or) room temperature as a reference. To implement this, hot junction is located on the device and the cold junction at the meter (or) transmitter as shown in the Fig.

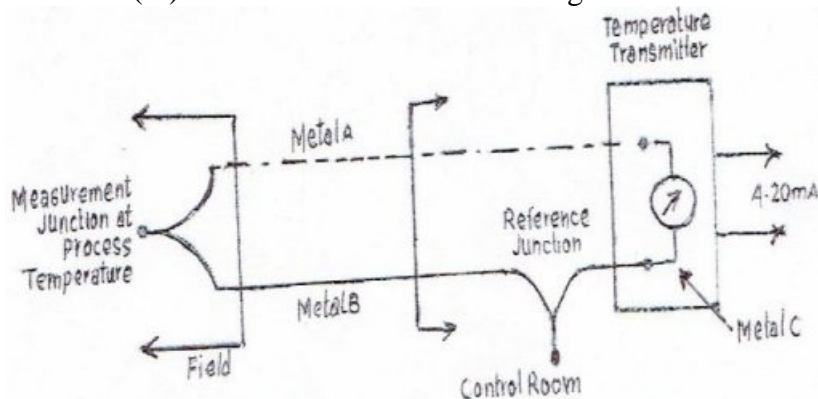

Fig 1.34 Simplified Thermocouple Temperature Transmitter

QUESTIONS

Part A

1. Name the various mechanical methods used in temperature measurement.
2. State the principle used in Liquid in Glass thermometer.
3. What are the liquids used in Liquid in Glass thermometer?
4. Mention the principle used in Gas thermometer.
5. List out the liquids used in Vapour pressure thermometer.
6. State the working principle of Bimetallic thermometer.
7. Name the metals used in Bimetallic thermometer.
8. List out the various electrical methods to measure the temperature.
9. Mention the materials used in thermistor.
10. Draw the types of thermistors.
11. List out the materials used in RTD.
12. Draw the RTD Wheatstone bridge circuit.
13. What is PT-50 and PT-100?
14. Draw the characteristics of RTD and Thermistor.
15. State Seebeck effect.
16. What is Thermopile?
17. List out the non-contact methods of temperature measurement.
18. What is pyrometer?

Part B

1. Brief the operation of Liquid in metal thermometer with a sketch..
2. Write short notes on Bimetallic thermometer.
3. Describe about the RTD 3 wire system.
4. List out the advantages and limitations of RTD.
5. Table the types of thermocouples with details.
6. Discuss about Cold junction compensation in thermocouples.
7. Briefly discuss about any two thermoelectric laws.
8. Write notes on Series and Parallel combinations of thermocouples.
9. In detail discuss about Thermopile.
10. Discuss briefly about Bolometer.
11. List out the advantages and limitations of Thermocouples.
12. Write short notes on Temperature transmitter.

Part C

1. Explain Liquid in glass and Liquid in metal thermometer with a neat sketch. .
2. Explain Gas Thermometer in detail with a neat sketch.
3. Sketch and explain Vapour Pressure Thermometer.
4. Explain the principle and working of Bimetallic Thermometer with a neat sketch.
5. Explain the various bridge circuit used in RTD for temperature measurement.
6. Explain the Principle, types and construction of Thermocouples
7. State and explain the Thermoelectric laws.
8. With a neat diagram explain the Potentiometric temperature measurement method of thermocouple.
9. In detail explain Total Radiation Pyrometer.
10. Describe the temperature measurement by an optical pyrometer with a neat sketch.

UNIT-II MEASUREMENT OF PRESSURE

1. PRESSURE: - Pressure is defined as the force applied over a surface. It is defined as force per unit area.

$$\text{Pressure } P = \text{Force } (F) / \text{Area } (A)$$

The units for pressure are **Psi** and **Kg/Cm²**

2. IMPORTANCE OF PRESSURE MEASUREMENT

(a) Safety: - Equipment used with pressurized fluids is designed to tolerate specific range of pressures. Pressure measurement and control helps to prevent the bursting of pipes and vessels, damage to equipment and personal injury.

(b) Efficiency: - In most cases, process efficiency is high when the pressures are maintained at particular values.

(c) Economy: - Precise Pressure Measurement can help to prevent the unnecessary expense of creating more pressure (or) vacuum than required to produce desired results.

3. PRESSURE TERMINOLOGY:-

(a) Atmospheric Pressure: - The air in the atmosphere has weight, and this weight is pressed against the surface of the earth by gravity. The nominal value of atmospheric pressure is **14.7 PSI** at sea level, under normal atmospheric conditions. Atmospheric pressure decreases at increasing altitudes.

(b) Barometer: - A device for measuring Atmospheric Pressure.

4. TYPES OF PRESSURE: -

The types of pressure can be commonly classified as

1. Gauge Pressure.
2. Absolute Pressure.
3. Differential Pressure.

Pressure measurement always shows the measured pressure as compared to a Reference pressure.

(1) Gauge Pressure:- The pressure of a fluid is compared to an atmospheric pressure. The unit is psig (Pounds per square inch, gauge).

(2) Absolute Pressure:- The pressure of a fluid is compared to a vacuum. The unit is **Psia**.

(3) Differential Pressure:- The difference between two measured pressures, commonly expressed in terms of psid (Pounds per square inch, differential).

Note: -Gauge pressure → Reference is Atmospheric pressure.
Absolute pressure → Reference is Vacuum.
Differential pressure → Reference is second measured pressure.

5. UNITS OF PRESSURE & CONVERSION BETWEEN UNITS:-

The most commonly used Pressure units are Psi {Pounds per square inch} and Kg/cm². Some other Pressure units available are N/m², Pa, kPa, bar, micron, torr, mmHg. Some of the Pressure conversion between the units is given below: -

1 Newton Per Square metre (1 N/m²) = 1 Pascal (1Pa)

1 Atmospheric Pressure (1 atm) = 14.7 Psi = 1Kg/cm² = 101.3 kPa = 760 mmHg

1 millibar = 100 dyne/cm² = 14.5 x 10⁽⁻³⁾ Psi

1 micron = 10⁽⁻⁶⁾ m Hg = 19.34*10⁽⁻⁶⁾ Psi

1 torr = 1 mmHg = 1000 microns = 133 N/m² = 133 Pa

1 inch of water = 249.1 N/m² = 249.1 Pa

6. MANOMETER

6.1) U-TUBE MANOMETER:-

A manometer is a device used to measure relatively low pressure. In terms of construction, it is essentially a glass tube bent into a U- shape, so that two columns result. The device is filled with liquid such as **water** (or) **mercury**. Each column is exposed to a

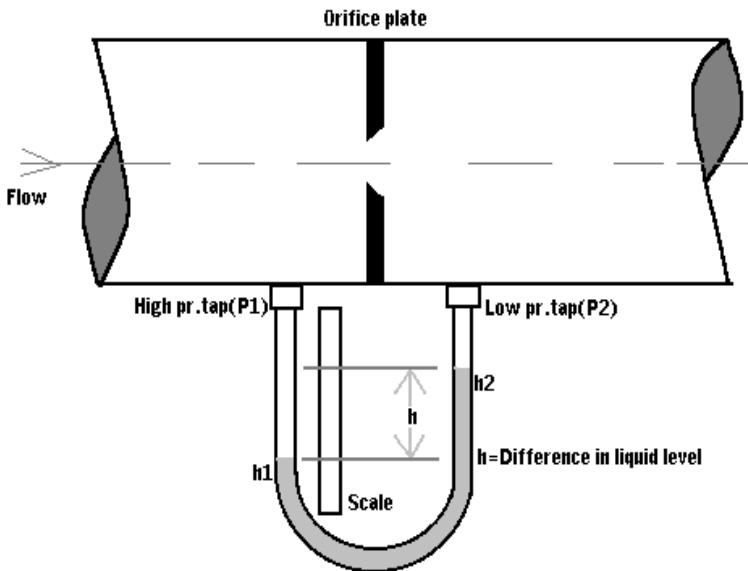

source of pressure. Pressure can be read by comparing the height of two columns.

Measurements are typically given in terms of inches of water column (or) millimeters of Hg (mmHg). When there is a pressure difference between two ends of the tube, the liquid level goes down on one side of the tube and up on the other side.

WORKING:- The difference in liquid levels from one side to the other indicates the difference in pressure. The differential pressure (P1-P2) is obtained by

Fig 2.1 U-Tube Manometer

$$(P1-P2) = (\rho-\rho1)(h1-h2) g$$

$$= (\rho-\rho1) hg \quad [\because h=h1-h2]$$

ρ = density of fluid in U-tube.

$\rho1$ = density of fluid whose pressure is being measured.

h = (h1-h2) difference in fluid levels.

g = acceleration due to gravity.

When manometer is used to measure low pressure then **water** is used as the liquid, and when manometer is used to measure high pressure then **mercury** is used as the liquid.

Manometer Applications:-

1. Gauge Pressure:- If the high-pressure column is connected to a measured pressure and the other column is open to atmosphere, then the reference pressure is atmospheric pressure. So the device measures Gauge Pressure

2. Absolute Pressure:- If the high-pressure column is connected to a pressure and the top of the other column is sealed, then the reference pressure is vacuum. So the device measures Absolute Pressure.

3. Differential pressure:- If each column is connected to a different source of pressure, the difference in column heights will show the Differential Pressure.

The U-tube manometer is simple and accurate. However U-tube manometers are not always easy to use, because both columns must be read. The Well type manometer overcomes this disadvantage.

Fig 2.2 Manometer Applications

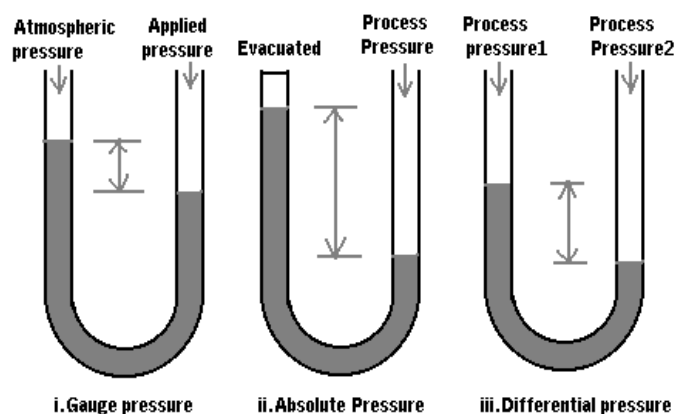

6.2) WELL TYPE MANOMETER:-

In the well type manometer, one side of the device is a container (or) well filled with liquid. Because of the larger surface area of the well, a small change in the level of the well produces much larger change in the fluid level in the tube. This makes it easier to measure small pressure change accurately. The advantage of this type of manometer is that a single scale reading is sufficient for the pressure difference.

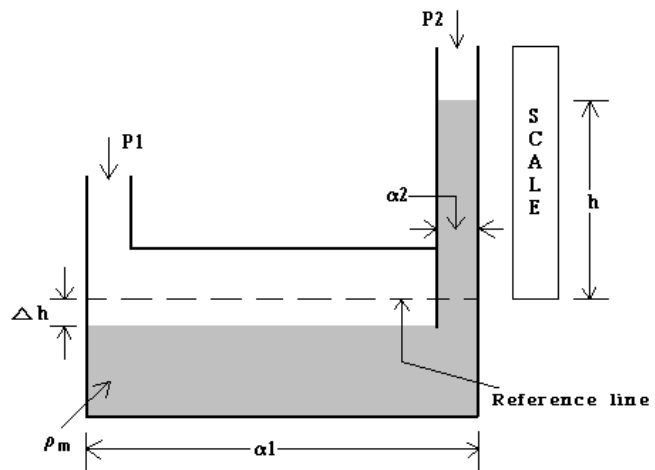

Fig 2.3 Well type manometer

α_1 = Area of the well.

α_2 = Area of the capillary.

Δh = Change in height in the well.

$P_1 - P_2$ = Pressure difference

$$P_1 - P_2 = (h + \Delta h) \rho_m$$

$$h \cdot \alpha_2 = \Delta h \cdot \alpha_1$$

$$P_1 - P_2 = (h + h \alpha_2 / \alpha_1) \rho_m$$

$$= \rho_m h [1 + \alpha_2 / \alpha_1] \quad [\because \alpha_2 \ll \alpha_1]$$

$$\boxed{P_1 - P_2 = \rho_m h} \quad (\text{or}) \quad \boxed{P_1 - P_2 = \rho h}$$

$$[\because \rho_m = \rho]$$

6.3) INCLINED TUBE MANOMETER (OR) DRAFT GAUGE MANOMETER:-

The Draft gauge (or) inclined manometer is a variation of Well type manometer. The indicating tube is set at an angle. So the change in fluid height is spread over a longer tube. This expands the scale and allows for more precise measurement. The angle of inclination is of the order 10° .

$$(P_1 - P_2) = \rho_m h \sin (90 - \beta) (1 + \alpha_2 / \alpha_1)$$

$$= \rho_m h \cos \beta (1 + \alpha_2 / \alpha_1) = \rho h \cos \beta (1 + \alpha_2 / \alpha_1) \quad [\because \rho_m = \rho]$$

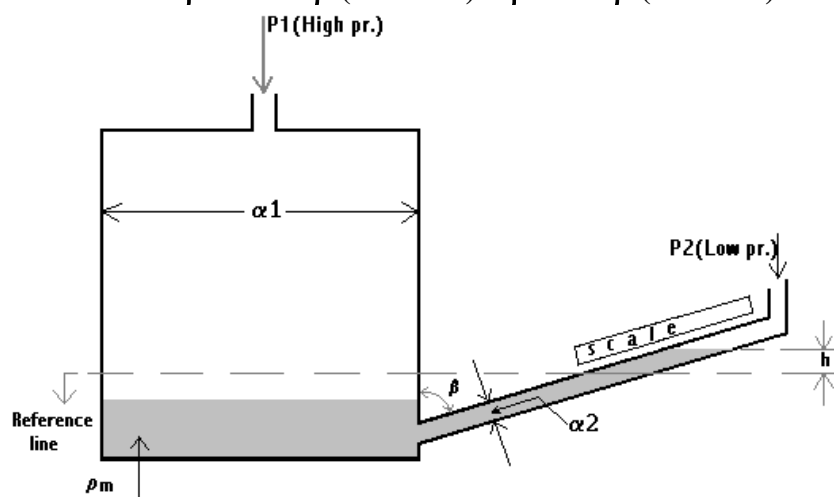

Fig 2.4 Inclined Tube Manometer

6.4) MICRO MANOMETER: -

Micrometer is used for accurate measurement of extremely small pressure difference. A Micro manometer consists of a well connected to a flexible tube whose one end is inclined as shown in the figure. A magnifier is attached to the inclined portion of the tube for observation of the fluid level. A micrometer is connected to the well for the observation of reading.

The Micro manometer initially adjusted, so that when pressure in the well and inclined portion becomes equal (i.e.) $P_1=P_2$, the meniscus in the inclined tube is located at a reference point viewed through a magnifier. The reading of the micrometer which is used to adjust the well height is also noted. Now, the unknown pressure difference causes the meniscus to move off, which can be restored to its initial position by raising or lowering the well with the micrometer. The difference between the initial and final micrometer readings gives the change in the height and thus the pressure.

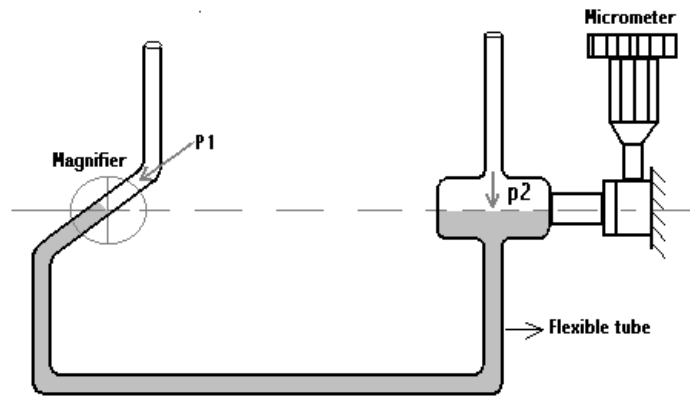

Fig 2.5 Micro Manometer

ADVANTAGES OF MANOMETERS:-

1. High accuracy and sensitivity.
2. Availability of wide range of filling fluids of varying specific gravities.
3. Simple and reasonable cost.
4. Suitability for low pressure and low differential pressure application.

LIMITATIONS OF MANOMETERS:-

1. Large and bulky.
2. Need for leveling.
3. Lack of portability.
4. Measuring fluid must be compatible with manometer fluid.
5. No over range protection.
6. Condensation may create problem.

7. ELASTIC ELEMENTS

An elastic element is any device that when connected to a source of pressure will **deform** (or) **change its shape**. To make a gauge, the elastic element is connected to an indicator such as a pointer that moves over a calibrated scale to give direct pressure reading.

The commonly used elastic pressure sensing elements are

1. Diaphragm
2. Bourdon tube.
3. Bellows.
4. Capsules.

7.1) DIAPHRAGM:-

The commonly used elastic element is diaphragm. It can be made up of **flexible materials** such as **rubber-coated fabrics** (or) it can be made up of **metals and metallic materials**. When the pressure is higher on one side of the diaphragm than the other, the diaphragm stretches toward the lower pressure. Diaphragms are available in several shapes and materials of construction.

The diaphragms can be in the form of **Flat** and **Corrugated** diaphragm and the choice depend on the strength and amount of deflection desired.

Corrugated shape diaphragm gives greater

Fig 2.6 Gauge with diaphragm

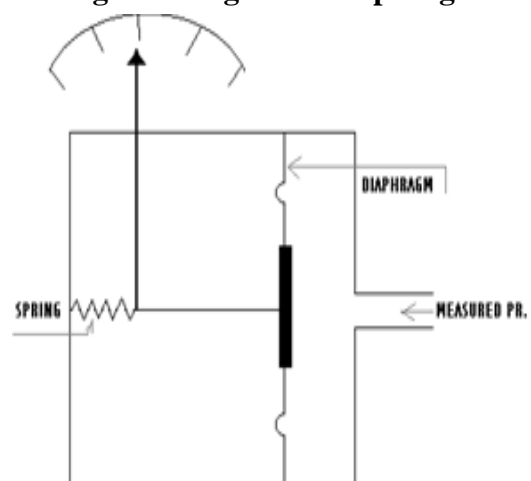

range of movement than Flat diaphragm. Non-metallic diaphragms are well suited to low pressure measurement. They do not have good spring properties and it also requires an opposing force to return them to their original position.

Metals and metallic diaphragms can be used with higher temperature and pressures. They have better spring properties and easily return to their original position. Flat metal diaphragms tend to produce non-linear output because the amount of deflection is not always proportional to the measured pressure.

ADVANTAGES OF DIAPHRAGMS:-

1. Moderate cost.
2. Good linearity.
3. Availability in several materials for good corrosion resistance.
4. Small size.
5. Adaptability to slurry services.

LIMITATIONS OF DIAPHRAGMS:-

1. Difficult to repair.
2. Limited to relatively low pressures.

7.2) BOURDON TUBE

The Bourdon tube is the most frequently used pressure gauge because of its Simplicity and Rugged construction. A Bourdon tube is hollow, spring like element that is closed at one end and connected to measured pressure at the other end. Bourdon tubes are available in several shapes. They are **C-shaped, Twisted, Helical** and **Spiral**.

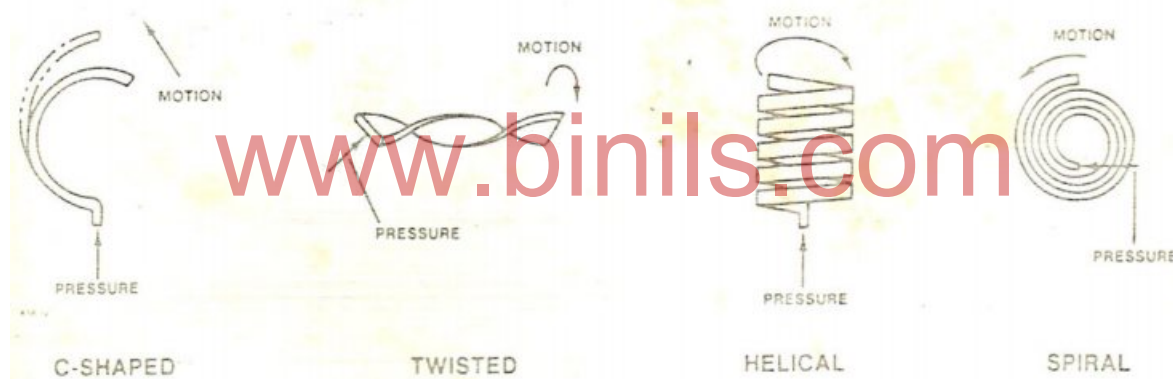
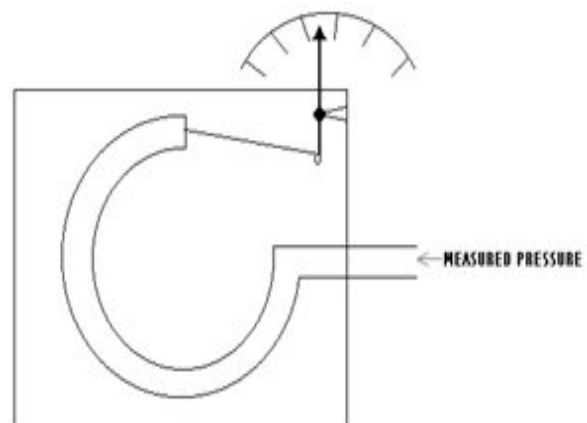

Fig 2.7 Various shapes of Bourdon Tubes

Increases in pressure causes the Bourdon tube to deform (straighten out (or) unwind). When the pressure is reduced, the Bourdon tube relaxes towards its original shape, in a common application. The Reference Pressure for Bourdon tube is Atmospheric pressure Hence it measures Gauge Pressure.

The Bourdon tube is one of the oldest mechanical instrument and remains a very popular pressure sensing device. They are commonly available to measure pressure ranges from **0-15 Psi to 0-6000 Psi**. Bourdon tube are made up of a number of materials, depending upon the fluid and pressure for which they are used, such as **Brass, Bronze, Phosphor Bronze, Alloy Steel, Stainless Steel, Monel Metal and Beryllium Copper**.

Phosphor Bronze is used in low pressure applications and when the medium is non-corrosive. **Stainless Steel (or) Monel** is used in high pressure applications and when the medium is corrosive.



ADVANTAGES OF BOURDON TUBE: -

1. Low cost.
2. Simple construction.
3. Availability on a wide variety of ranges, including very high ranges.

LIMITATIONS OF BOURDON TUBES: -

1. Low spring gradient. (Below 50 psig)
2. Susceptibility to hysteresis.
3. Susceptibility to shock and vibration.

7.3) BELLOWS AND CAPSULES: -

Other common sensing elements are Bellows and Capsules. These devices consist of a flexible chamber with walls. The measured pressure is directed into the device. As the pressure increases, the device expands its length.

Fig 2.9 Gauge with Capsule and Bellows

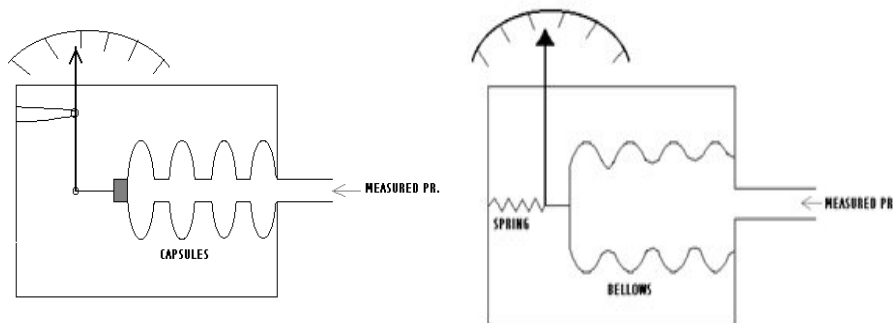

The major difference between Capsular element and Bellows is that Bellows is formed from a single piece of metal, while Capsule is made up of several diaphragms like elements welded together.

The Capsule has good spring properties (will return to its original shape when depressurized). But the Bellows often requires a spring (or) other element to pull it back to its original form. Therefore Capsules are generally preferred for measurement instruments, while bellows are used in other instrumentation applications.

8. ELECTRICAL METHODS OF PRESSURE MEASUREMENT

In the electrical pressure transducers, the physical quantity is converted into an electrical signal. Most of the electrical transducers have three elements. They are,

- (a) Sensor
- (b) Transducer
- (c) Associated Electronics

(a) Sensor:- Pressure sensing element such as bellows, diaphragms, bourdon tube (or) any other elastic element.

(b) Transducer:- The transducer is the component (or) group of components that converts deformation of the elastic element into a change in some electrical property such as Voltage, Resistance, Capacitance etc.

(c) Associated Electronics:- The associated electronics receive the signal from the transducer and convert it into standard control signal.

TYPES OF COMMONLY USED ELECTRICAL PRESSURE TRANSDUCER: -

1. Strain Gauge (Resistance) Pressure Measurement.
2. Capacitive Pressure Transducer
3. Inductive Pressure Transducer.
4. Piezoelectric Pressure Transducer.

8.1) STRAIN GAUGE PRESSURE MEASUREMENT: -

Strain Gauge operates on the principle of **Piezo Resistive effect**. (i.e.) The wire's electrical resistance is a function of three parameters. They are type of wire (ρ), its length (l) and its Cross-Sectional Area (A).

$$R = \rho l / A$$

If an elastic element is attached to strain sensitive wire, the length (l) and Cross sectional Area (A) of the wire will change in response to the changes in measured pressure. This results in a change in wire's electrical resistance, which can be converted into a control signal. It is a **Passive type Resistance Pressure Transducer**.

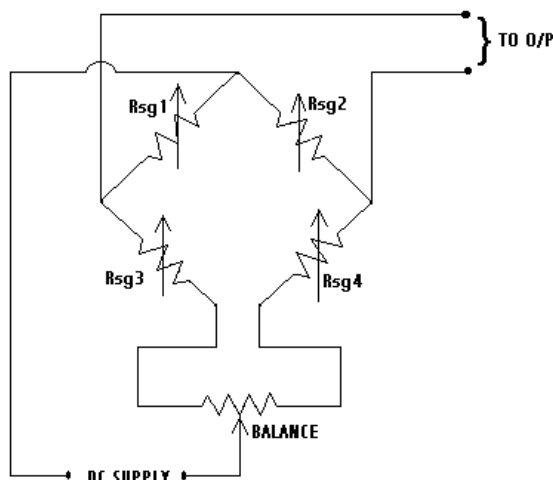

Fig 2.10 Strain Gauge Bridge Circuit

PRINCIPLE: -

The Strain Gauge is a fine wire, which changes its resistance when mechanically strained, due to Physical effects. A Strain Gauge is attached to the diaphragm, so that when the process pressure is applied to the diaphragm, the Strain Gauge stretches (or) compresses. This deformation of the Strain Gauge causes the change in Resistance.

The resistance change of a Strain Gauge is converted into Voltage, by connecting one, two (or) four similar Gauges, as of wheat stone bridge (Strain Gauge Bridge) and applying excitation to the bridge. The bridge output Voltage is then a measure of the Pressure sensed by the Strain Gauge.

CONSTRUCTION AND WORKING: -

Fig. shows a bridge circuit with four Strain Gauges Rsg1, Rsg2, Rsg3 and Rsg4. Two Strain Gauges Rsg1 and Rsg4 are mounted in such a way that increasing pressure increases their resistance. The Remaining 2 Strain Gauges Rsg2 and Rsg3 are mounted so that increasing pressure decreases their resistance. A change in temperature affects all the four Strain Gauges, resulting in no change in the Pressure Indication.

At balance condition, when there is no pressure, no current flows through Galvanometer. When the pressure is applied, the strain Gauge Stretches (or) compresses accordingly and the bridge circuit becomes unbalanced. Thus, current flows through the Galvanometer during unbalanced condition. So, the change in current indicates the changes in measured pressure

Fig.2.11 Strain Gauge Pressure Transducer

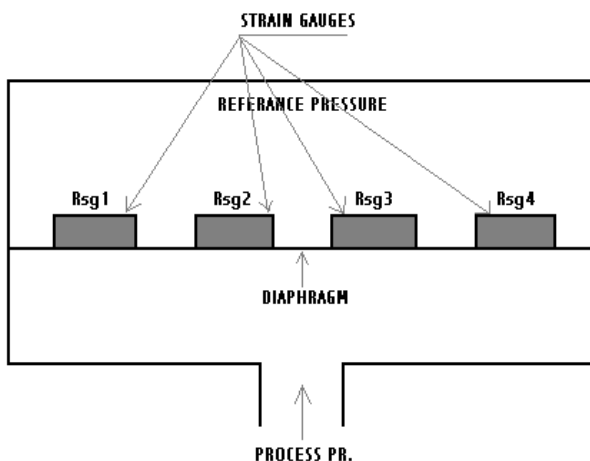

ADVANTAGES OF STRAIN GAUGE PRESSURE TRANSDUCER: -

1. Sensitive to small pressure change.
2. Small size.
3. Good accuracy.
4. Compatible with electronic system.
5. Fast response.

LIMITATIONS OF STRAIN GAUGE PRESSURE TRANSDUCER: -

1. Require constant voltage supply.
2. Electrical readout necessary.
3. Temperature compensation required.

8.2) CAPACITIVE PRESSURE TRANSDUCER: -

Capacitor is a device that has the ability to store electric charge. It consists of two conductive plates that are placed adjacent, but not touching each other. And these plates are separated by an insulating medium such as air (or) oil called dielectric. The amount of capacitance is determined by three parameters.

$$C = \frac{\xi A}{d}$$

A = Area of the Plate

d = Distance between the two plates

ξ = Dielectric Constant

PRINCIPLE: -

The operation of Capacitive Pressure Transducer is shown in the Fig. If one of the capacitor plates is connected by an elastic element, a change in measured pressure will result in a change in the distance between the two plates and a corresponding change in capacitance takes place. The changes in capacitance can be translated electronically into changes in a control signal.

Fig 2.12 Capacitive Pressure Transducer

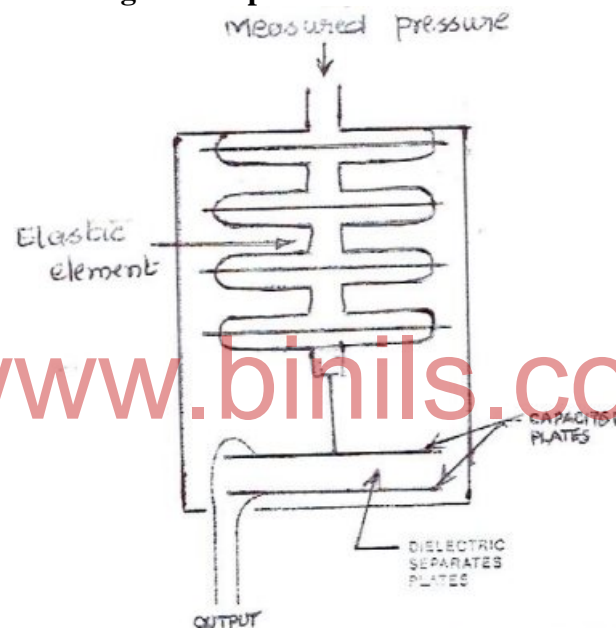

COMMON DESIGN OF CAPACITIVE PRESSURE TRANSDUCER: -

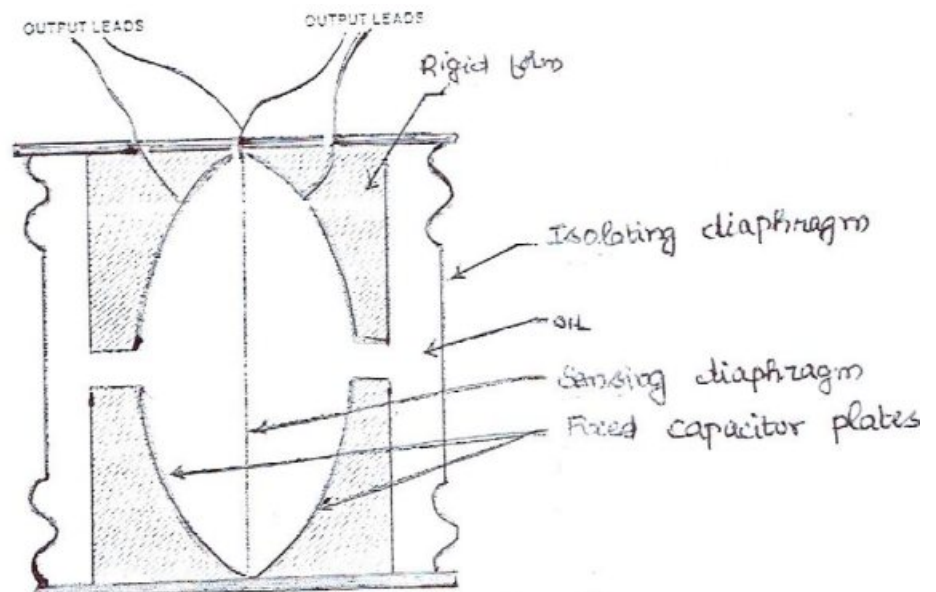

Fig 2.13 Common design of Capacitive Pressure Transducer

In the Fig, two fixed plates are used in conjunction with one movable plate (or) Sensing diaphragm. This results in the formation of two capacitors. An Isolating Diaphragm is used to protect the internal sensor from the process fluid. This pressure is transmitted by the dielectric oil through the openings in the centre of the fixed plates to the sensing diaphragm. The sensing diaphragm is a movable capacitor plate. As the measured pressure change, the sensing diaphragm moves resulting in a change in capacitance between the sensing diaphragm and each of the fixed plate.

ADVANTAGES OF CAPACITIVE PRESSURE TRANSDUCER: -

1. Very small
2. Economical
3. Extremely sensitive, so they can be used to measure small spans.

LIMITATIONS OF CAPACITIVE PRESSURE TRANSDUCER: -

1. Sensitive to temperature change hence it requires temperature compensation.

8.3) INDUCTIVE PRESSURE TRANSDUCER (LVDT): -

It works on the principle of **Variable Inductance**. The Centre coil is the Primary coil and is energized by an ac input. The Secondary coil is wound in two segments, one on either side of the Primary. The Secondary coils may be wired together so that the output of each is out of phase with the other. A ferrite core inside the tube is positioned by the deflection of an elastic element.

When the Core is in centre of the tube, the output from the two Secondary windings are equal and out of phase. So, the output is zero.

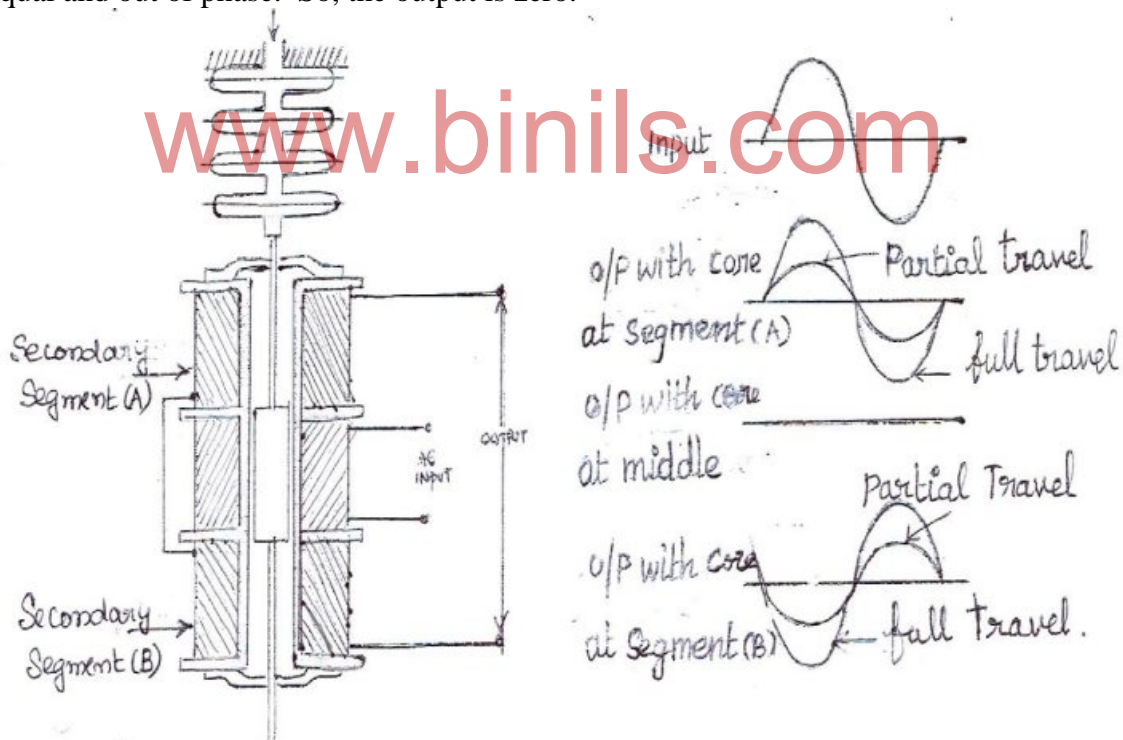

Fig 2.14 Inductive Pressure transducer

As the elastic element causes the core to move toward one segment of the Secondary coil, that segment of the Secondary coil is magnetically coupled to the primary and produces an increasing output with a particular phase. At the same time, the output from the other Secondary decreases.

If the elastic element moves the coil in other direction, the other Secondary produces larger output at a different phase. The transmitter includes circuitry that provides a standard control signal based on phase and magnitude of the ac voltage measured at the Secondary coil output.

ADVANTAGES OF INDUCTIVE PRESSURE TRANSDUCER: -

1. Rugged and Long-lasting.
2. It produces a linear output over the majority of the operating range.
3. It provides fast frequency response.

LIMITATIONS OF INDUCTIVE PRESSURE TRANSDUCER: -

1. Temperature sensitive.
2. Influenced by Stray magnetic fields.

8.4) PIEZO ELECTRIC PRESSURE TRANSDUCER: -

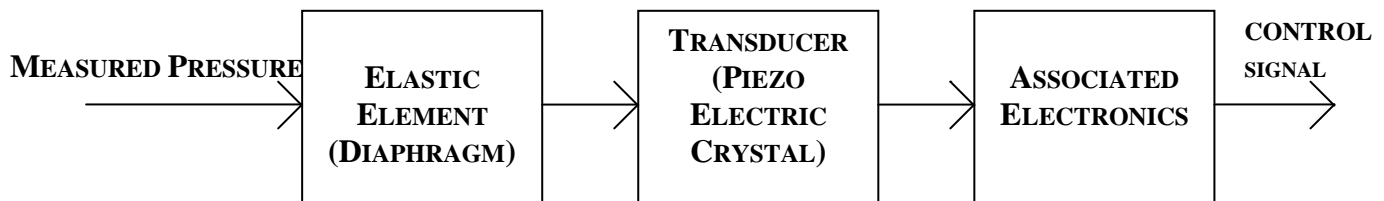
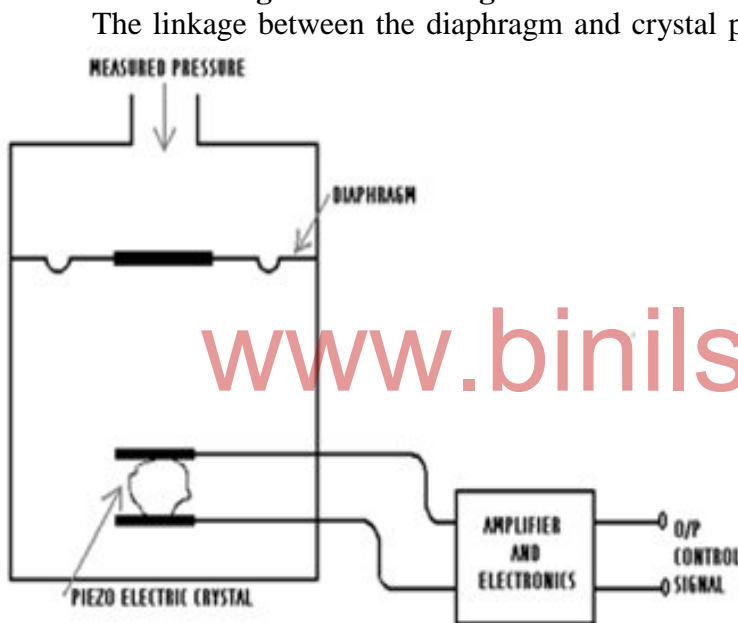

Fig 2.15 Block Diagram for Piezo Electric Pressure Transducer



www.binils.com

The linkage between the diaphragm and crystal produces a changing force on Piezo electric crystal when the measured pressure changes. The Piezo electric crystal produces voltage when the pressure is applied to it. To make the unit complete, associated circuitry is used to amplify the voltage output of the crystal and convert it into a standard control signal output. Some of the Piezo electric materials are **Quartz Crystal, Barium Titanate, Sintered Powder, Tourmaline Crystal & Rochelle Salts**. The Piezo electric crystal generates electrical signal, which is amplified by a charge amplifier

Fig 2.16 Piezoelectric Transducer with pressure sensing element

The Second Piezo electric Crystal is included for the compensation of any acceleration of the device. This compensation is required because rapid acceleration of the device creates additional pressure on the Piezo electric Crystal. Signals from the compensating crystal are amplified by a second Charge amplifier. A Differential amplifier is used which subtracts pressure alone and all effects due to acceleration are removed. The Piezo electric Crystal is used where rapidly fluctuating change in the force applied to it and does not give a useful signal. It can also give a large change in the output for a given

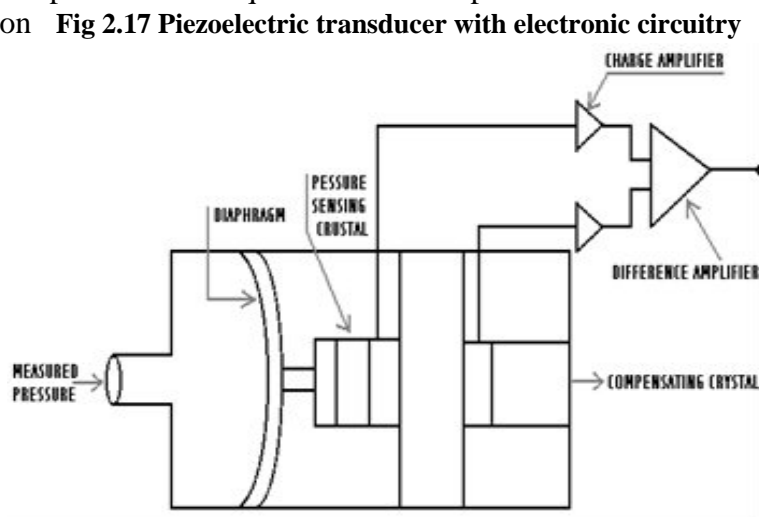

change in applied force. This can be used to measure pressure in the range of **0 - 50,000 Psi**. They respond only to changing pressures.

ADVANTAGES OF PIEZO ELECTRIC PRESSURE TRANSDUCER: -

1. Needs no external power because it is a Self-generating device. (**Active type**).

LIMITATIONS OF PIEZO ELECTRIC PRESSURE TRANSDUCER: -

1. It cannot measure Static pressure.
2. It is affected by temperature changes. Therefore temperature compensation is required.

9. PRESSURE GAUGE CALIBRATION BY DEAD WEIGHT TESTER

The laboratory standard of pressure is a Dead Weight Tester and it is very often used to calibrate Bourdon gauge. It is a standard of Pressure measurement.

Dead Weight Piston Gauge is used for the measurement of higher steady pressures. In this, the force produced on a piston of known area is measured directly by the weight it supports. It consists of accurately machined and finished piston which is inserted into a close fitting cylinder. The cross-sectional area of the piston and the cylinder are known. At the top of the piston is provided a platform on which the Standard weight of the known accuracy can be placed. An oil Reservoir with a check valve at the bottom is also provided. The oil from the Reservoir can be sucked by a Displacement pump on its upward stroke.

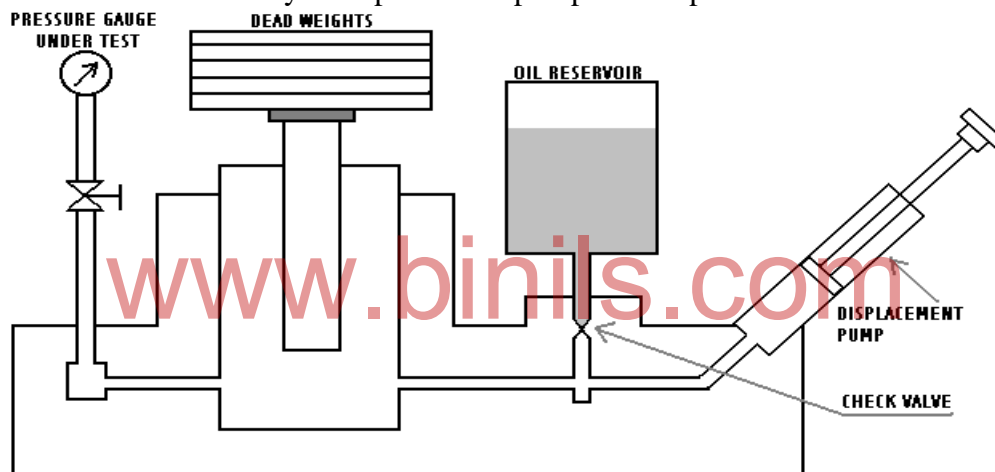

Fig 2.18 Dead Weight Piston Gauge

For calibration purposes, first a known weight is placed on the platform. Then the fluid pressure is applied on the other end of the piston until enough force is applied to lift the piston-weight combination. And the piston floats freely within the cylinder between the limit stops. The error in the dead weight tester is **< 0.1 %**. In order to reduce the friction between the piston and the cylinder, the piston is generally rotated while a reading is being taken. **Spinnestic Oil** is used in Dead Weight Piston Gauge.

10. DIFFERENTIAL PRESSURE TRANSMITTER: -

Most Pressure Transmitters are built by the Pressure Capsule concept. They are usually capable of measuring Differential Pressure (that is the difference between a High Pressure input and a Low Pressure input) and therefore usually called as **DP Transmitters** (or) **DP Cells**.

The Fig illustrates a typical DP Transmitter. A Differential Pressure Capsule is mounted inside housing. One end of a Force bar is connected to the Capsule assembly so that the movement of the Capsule can be transmitted to outside of the housing. A sealing mechanism is used where the Force bar penetrates the housing and also acts as the Pivot point for the Force bar. Provision is made in the housing for High Pressure fluid to be applied on one side of the Capsule and the Low Pressure fluid on the other. Any difference in pressure causes the Capsule to deflect and create movement in the Force bar. The top end of the Force

bar is connected to a Position detector, which is an electronic system produces 4-20mA signal that is proportional to the Force bar movement.

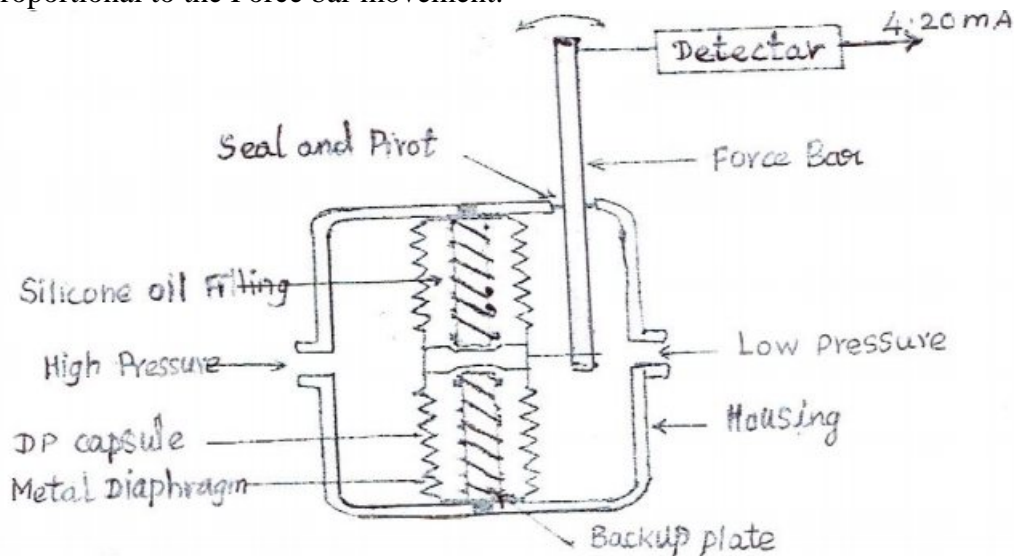

Fig 2.19 DP Transmitter Construction

INSTALLATION OF DP TRANSMITTER: -

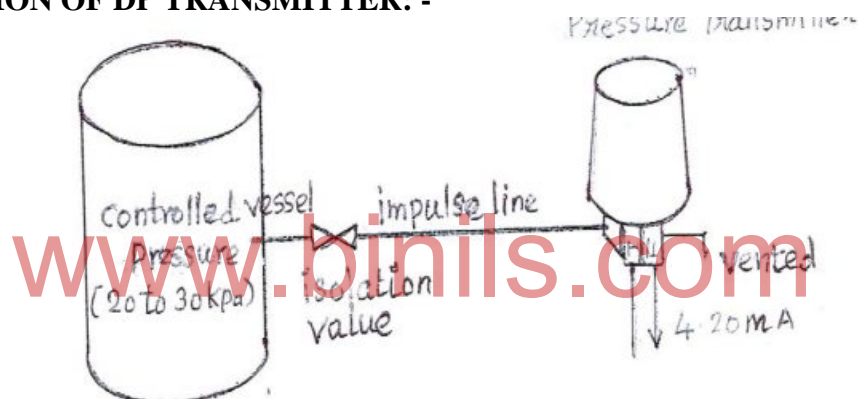

Fig 2.20 Installation of DP Transmitter

The DP Transmitter can be installed as shown in the Fig. In this example, a DP Transmitter is used to measure the gas pressure inside a vessel. The Low Pressure side of the Transmitter is vented to atmosphere and the High Pressure side is connected to the vessel through an isolating valve. The isolating valve is used for removing the Transmitter. The output of the DP Transmitter is proportional to the gauge pressure of the gas. (ie) 4mA when the pressure is 20 KPa and 20 mA when the pressure is 30 KPa.

11. DATA TRANSMISSION THEORY AND TELEMETRY SYSTEM:-

The term **data transmission** and **telemetry** refers to the processing of information by using a transducer and signal conditioner and it can be transferred to a remote location for displaying, controlling (or) recording.

Methods of data transmission:-

The methods used for the data transmission depends on the variable and distance of transmission. The following methods are used for the data transmission

- (1) Hydraulic transmission
- (2) Pneumatic transmission
- (3) Electrical and Electronic transmission

The electrical and electronic methods of data transmission are commonly used in measurement systems.

11.1 GENERAL TELEMETRY SYSTEM:-

Telemetry is defined as measurement at a distance. A general telemetry system is shown in the fig. The function of primary sensing element & end device of the telemetry system and generalized measurement system are same. But there are three system elements in the intermediate stage of telemetry system are unique and they are

- (i) Telemeter transmitter
- (ii) Telemetry channel
- (iii) Telemeter receiver

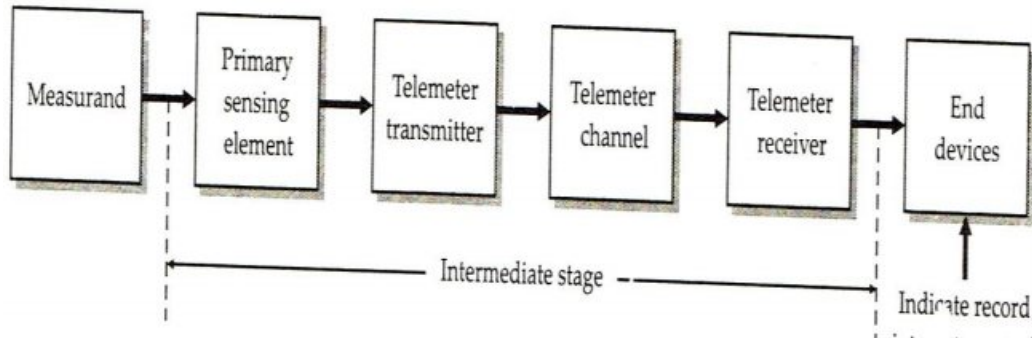

Fig 2.21 Block diagram of a general telemetry system

The function of the telemeter transmitter is to convert the output of a primary sensing element into an electrical signal and transmit it over a telemetering channel. This electrical signal is received by a receiver placed in a remote location and it can be converted into an usable form which can be displayed, recorded (or) controlled.

The two types of commonly used telemetry systems are

- (1) Land line telemetry
- (2) RF (Radio frequency) telemetry.

11.2 RF (RADIO FREQUENCY) TELEMETRY SYSTEM:-

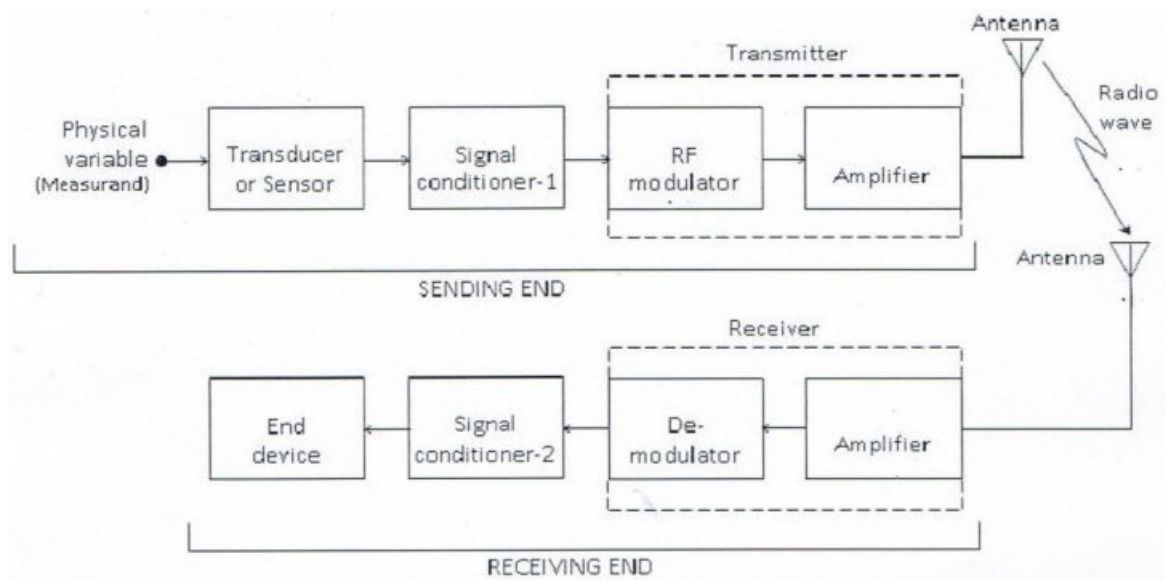

Fig 2.22 Block diagram of Radio frequency telemetry system

In Radio frequency telemetry system, physical link never exist between the transmitting and receiving stations. The link between the transmission station and the receiving station can be established through the radio links.

A test flight has many parameters which can change during the flight (ie) fuel flow, engine performance, vibrations of critical parts, temperature of various components etc. The

best way to analyze these parameters is by transmitting the test data to the land station from the aircraft through the radio links.

The rocket (or) unmanned space craft need a radio link based telemetry. In this, Radio frequency telemetry monitors all the information of the space craft by a team of engineers with the help of computer, while the flight is in progress. RF telemetry is more suitable if the data is transmitted over distances greater than 1 km.

Radio links in flight vehicles employs Pulse Duration Modulation (PDM)-Frequency Modulated (FM) systems.

11.3 MODULATION AND DEMODULATION:-

(A) MODULATION METHODS:-

Modulation technique is used to change the signal characteristics. The modulation methods used for transmission in Radio frequency telemetry are applicable to land line transmission. A signal can be described by its (a) amplitude (b) frequency and (c) phase shift. Accordingly three methods of modulation are used and they are

- (i) Amplitude modulation
- (ii) Frequency modulation
- (iii) Phase modulation

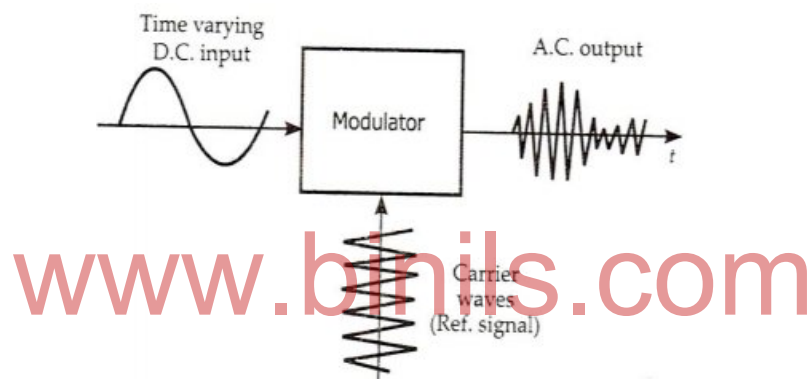

Fig 2.23 Basic Configuration of a modulator

(i) Amplitude modulation:-

In amplitude modulation, the amplitude of a carrier signal is varied by a modulating voltage signal whose frequency is much lower than that of the carrier. In instrumentation systems, the modulating signal is the output voltage of a transducer which is generated by the application.

(ii) Frequency modulation:-

Frequency modulation is a system in which the amplitude of the modulated carrier is kept constant, while its frequency is varied by the modulating signal. The general equation of an unmodulated wave (or) carrier can be written as

$$X = A \sin (\omega t + \theta)$$

- Where
- x = instantaneous values of current (or) voltage
 - A = maximum (amplitude) of current and voltage
 - ω = angular frequency (rad/s)
 - θ = phase angle (rad)

If any of these three parameters is varied with respect to another signal, normally at a lower frequency, then the second signal is called as modulating signal and the first is modulated by the second. Amplitude modulation is achieved when amplitude is varied, Phase modulation is obtained by varying the phase angle and the frequency of the carrier is varied to get frequency modulation.

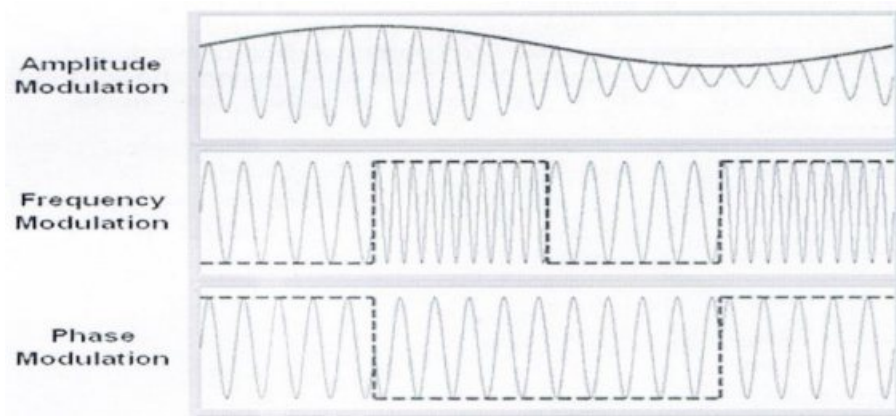

Fig 2.24 Amplitude, Frequency and Phase modulation

(iii) Phase modulation:-

When the phase of the signal is changed, then it affects the frequency. Therefore, the frequency modulation and phase modulation systems are closely related. Hence, it is possible to obtain frequency modulation from phase modulation.

(B) DEMODULATION METHODS:-

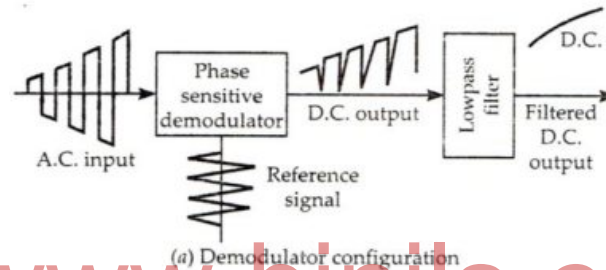

Fig 2.25 Demodulator configuration

In majority of the measurement systems, a phase sensitive demodulation is required, if the modulation is performed earlier to recover the algebraic sign of the original direction. In order that the sign of the original information to be recovered, it is essential that the reference signal used to drive the modulator must also be used in the demodulator. To eliminate the noise from the output a low pass filter must be introduced at the output of a demodulator.

QUESTIONS

Part A

1. What are the different types of pressure?
2. What is atmospheric pressure?
3. What is gauge pressure?
4. Define absolute pressure.
5. What is differential pressure?
6. Mention any four units of pressure.
7. List out the types of manometers.
8. What is the advantage of Well type manometer over U tube manometer?
9. Name the various pressure sensing elastic elements.
10. Mention the materials used to make bellows.
11. Draw the various shapes of Bourdon tubes.
12. List out the types of electrical pressure transducer.
13. State the principle of Strain gauge pressure transducer.
14. Give some examples for Piezoelectric materials.

15. What is the major advantage of Piezo electric Pressure transducer?
16. Which device is used for the calibration of pressure gauge?
17. What is DPT?
18. Define telemetry.
19. Draw the block diagram of a general telemetry system.

Part B

1. Define Gauge Pressure, Absolute Pressure and Differential Pressure.
2. State the working principle of a U tube manometer.
3. Mention the advantages and limitations of manometer.
4. Write short notes on diaphragm.
5. Discuss briefly about the Bourdon tube.
6. State the working principle of Capacitive pressure transducer.
7. Sketch Piezoelectric pressure transducer in detail.
8. Draw the diagram of Dead weight tester.
9. Write short notes on Radio frequency telemetry system.
10. Discuss briefly about the modulation methods used in telemetry system.

Part C

1. Explain the types of manometers with a neat sketch.
2. What are elastic elements? Explain any two in detail?
3. Sketch and explain Strain gauge Pressure Transducer.
4. With a sketch explain how change in capacitance is used in the pressure measurement.
5. Explain the pressure measurement using LVDT with a neat sketch.
6. Sketch and explain Piezo electric Pressure Transducer
7. Explain the working of Dead Weight Tester with a neat sketch.
8. With a neat sketch explain Differential Pressure Transmitter.

UNIT-III MEASUREMENT OF FLOW (MECHANICAL)

1. INTRODUCTION: - The measurement and control of flow can be said to be the very heart of process industries. Continuously operating process industries involves the movement of raw materials, products and waste throughout the process. It involves various measurement of flow. Measuring fluid flow is one of the most important aspects of process control.

2. FLOW TERMINOLOGY

(a) Volume Flow Rate: - Volume delivered per unit of time. Units are gpm (gallons/min), m³/hr.

(b) Mass Flow Rate: - Mass (or) Weight flowing per unit of time. Units are kg/hr. These relates to volume flow rate by $F = \rho Q$

F = Mass (or) Weight flow rate

ρ = Mass density or Weight density

Q = Volume flow rate

(c) Flow Velocity:- The distance of liquid travels in the pipe per unit time. Units are m/min

$$V = Q/A$$

V = Flow velocity

Q = Volume flow rate

A = Cross sectional area of pipe.

3. BERNOULLI'S THEOREM

From Bernoulli's equation on the Conservation of Energy, the Total head pressure (H) remains constant everywhere along the flow.

$$\frac{P}{\rho} + \frac{V^2}{2g} = H = \text{Constant}$$

The first term of the above equation is called as **Potential Head** (or) **Potential Energy**. The second term is called as **Velocity Head** (or) **Kinetic Energy**. Because of Potential and Kinetic energy together are constant, it is clear that an increase in velocity as described by the Equation of Continuity must also be accompanied by a decrease in Potential energy (or) line pressure. It is the relationship between Velocity and Pressure which provides the basis for the operation of all Head type meters.

4. CONTINUITY EQUATION:-

From the Equation of Continuity, assuming constant density (incompressible fluid) it can be seen that

$$Q_v = V_1 A_1 = V_2 A_2$$

This equation is one of the most important relationships in fluid mechanics. It demonstrates that for steady, uniform flow, a decrease in pipe diameter results in an increase in fluid velocity

5. REYNOLDS NUMBER

The most important flow factors can be correlated together into a dimensionless parameter called the **Reynolds Number**. The Reynolds number describes the flow for all velocity, viscosity and pipeline sizes. It is defined as **$R_D = \text{Velocity forces driving the fluid} / \text{Viscosity forces restraining the fluid}$** .

$$R_D = VD\phi / \mu$$

V = Fluid velocity

D = Dia of pipe

ϕ = Mass density of fluid

μ = Absolute Viscosity of the fluid

6. TYPES OF FLOW

The flow rate and pattern of flow in the pipe are classified into two types as **Laminar flow** and **Turbulent flow**.

Fig 3.1 Laminar and Turbulent flow

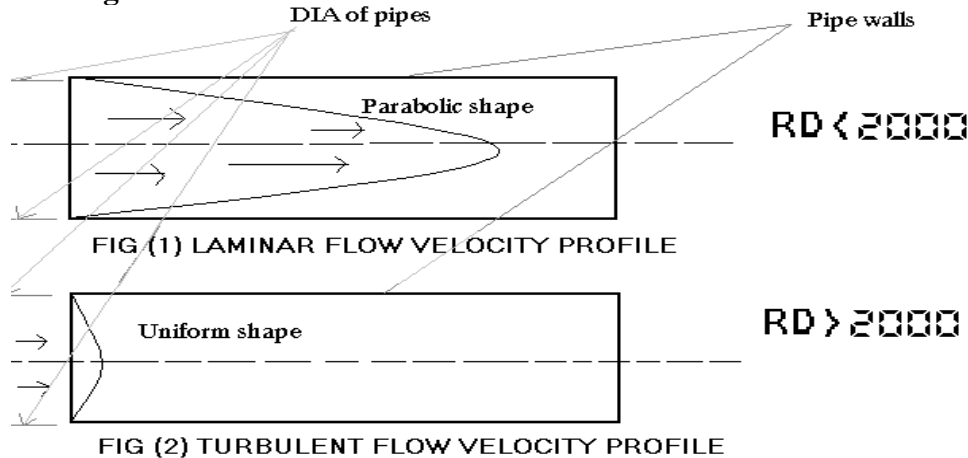

(a) Laminar Flow:- At very low velocity or high viscosity, Re is low and the fluid flow in smooth layers with the higher velocity at the center of the pipe and low velocity at the pipe wall as in figure. This type of flow is called as Laminar flow and it is represented by Reynolds number below 2000. The significant characteristic of Laminar flow is the **parabolic shape** of Velocity profile.

(b) Turbulent Flow:- At higher velocity or low viscosity, the flow breaks up into turbulent eddies where all the flow through the pipe has the same average velocity as in figure. The Velocity profile of Turbulent flow is **uniform in shape**. Turbulent flow is represented by Reynolds number above 4000.

7. INFERENCEAL FLOW METERS

Most flow rates are determined by inferential measurements. Inferential methods imply that the flow is not directly measured but it is inferred from measurements of other quantities which are related. These quantities may be pressure, temperature, force, velocity etc. For eg:- the information obtained from the sensors can be converted into velocity. Some of the inferential methods for the flow rate measurements are

1. Target Flow Meter: - The Flow rate is inferred from a force measurement.
2. Turbine Flow Meter: - The Flow rate is inferred from a Velocity.
3. Swirl Flow Meter: - The Flow rate is inferred from temperature oscillations.

8. DIFFERENTIAL PRESSURE TYPE FLOW METERS (or) HEAD METERS (or) RESTRICTION TYPE FLOW TRANSDUCERS:-

One of the most common methods of measuring the flow of liquids in pipes is by introducing a restriction in the pipe and measuring the pressure drop that results across the restriction. When such a restriction is placed in the pipe the velocity of the fluid increases after the restriction hence the pressure in the restriction decreases.

The relationship between pressure drop and flow create is given by $Q = K \cdot \sqrt{\Delta p}$

Q = Volume flow rate

K = a constant for pipe and liquid type

Δp = Pressure drop across the restriction.

Differential pressure type flow meters are generally simple, reliable and offer more flexibility than other flow measurement methods. This type of flow meter always consists of two components. They are

- (a) Primary device
- (b) Secondary device

PRIMARY DEVICES: - The primary devices are placed in the pipe to restrict the flow and develop a differential pressure. They are: (i) Orifice plates (ii) Venturi meter (iii) Flow Nozzle (iv) Dahl tubes (v) Pitot tube (vi) Annular tubes etc.

SECONDARY DEVICES:- The secondary device measures the differential pressure and provides a readout or signal for transmission to a control system. They are (i) Manometers (ii) Bellow meters (iii) Force balance meters (iv) Ring balance meters.

With restriction meters, calibration of primary measuring device is not required in the field. The primary device can be selected for compatibility with the specific fluid or application and the secondary device can be selected for the type of readout or signal transmission desired.

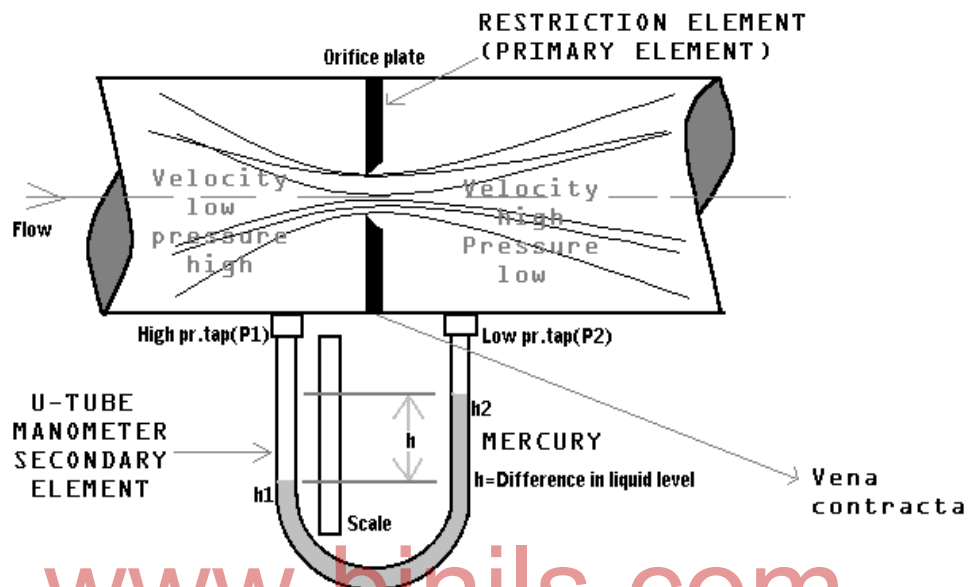

Fig 3.2 Differential Pressure Flow meter

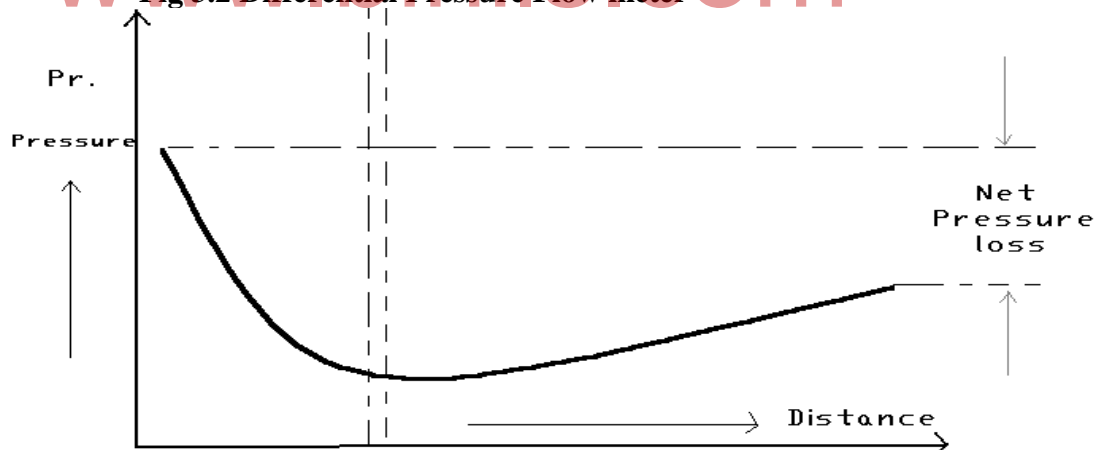

Fig 3.3 Pressure loss curve for Differential Pressure Flow meter

Note:- Vena contracta is defined as the smallest cross sectional area of the flow stream where the velocity is maximum and pressure is minimum.

9. TYPES OF RESTRICTION TYPE PRIMARY MEASURING ELEMENTS:-

They are:-

1. Orifice Plates
2. Venturi Tubes
3. Flow Nozzles
4. Dahl Tubes
5. Pitot Tubes
6. Annular Tubes

9.1) VENTURI TUBE

Venturi tube gives a very low-pressure loss compared to other differential pressure head meters. In addition, the largest and most costly comparing to orifice plates and flow nozzle.

CONSTRUCTION & WORKING:-

It consists of a straight inlet section of same dia as the pipe has a **convergent entrance or inlet cone, throat** and a **divergent outlet or outlet cone**. The high-pressure tap is located in the upstream line section of same dia as the pipe and low-pressure tap is located in the middle of the throat section. Venturi tube operates by gradually narrowing the dia of the pipe and measure the resultant drop in pressure. An expanding section of the Venturi meter then returns the flow to very near its original pressure. Venturi tube applications are generally restricted to those requiring a low pressure drop and high accuracy reading,

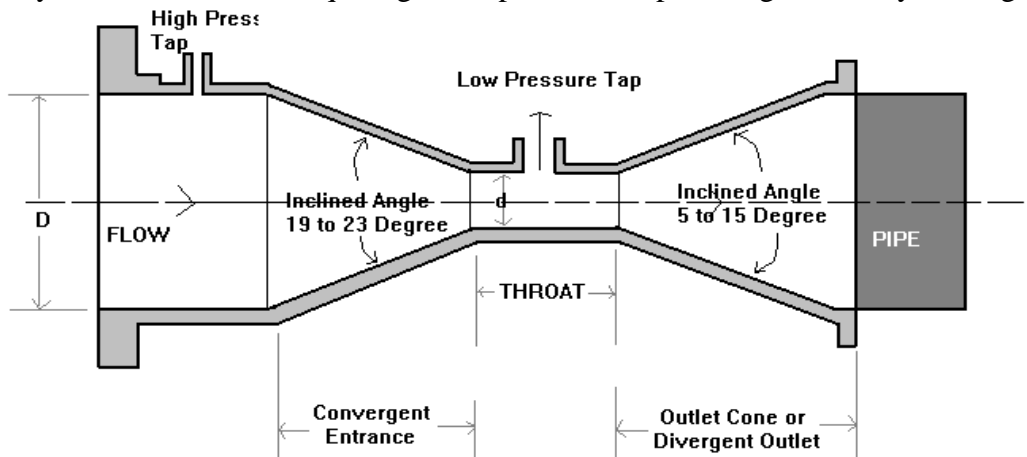

Fig 3.4 Venturi Tube

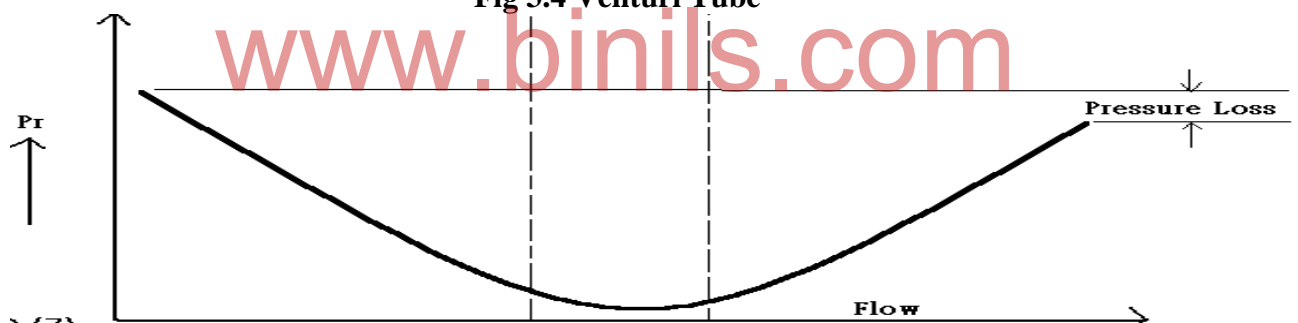

Fig 3.5 Pressure variation of Venturi Tube

Applications:- It is widely used in large dia pipes such as found in **Waste Treatment Plants** because their gradually sloping shape will allow the solids to flow through.

Material Used:- It is usually made up of **Cast iron** or **Steel**.

Types: The design of Venturi tubes are classified as:

- a. **Short Recovery Cone Type.**
- b. **Long Recovery Cone Type**

Sizes: - Venturi tubes available in sizes from **100 mm to 813 mm**.

Accuracy: - The accuracy range is $\pm 1/4\%$ to $\pm 3\%$

ADVANTAGES:-

1. Causes low permanent Pressure loss
2. Available in very large pipe sizes
3. Has well known characteristics
4. More accuracy over orifice plates and flow nozzle.

LIMITATIONS:-

1. High Cost
2. Not useful below 76.2 mm pipe sizes.
3. More difficult to inspect due to its construction.

9.2) FLOW NOZZLE

The flow nozzle is a variation of Venturi tube in which there is no outlet area for pressure recovery. The Nozzle opening is an elliptical restriction. It consists of a **convergent Inlet** whose shape is a quarter ellipse and a **cylindrical throat**. Pressure taps are located approximately $\frac{1}{2}$ pipe dia downstream and 1 pipe dia upstream. The pressure drop of flow nozzle falls between Venturi tube and orifice plate. The flow Nozzle is a high velocity flow meter used where turbulence is high i.e. $Re > 50000$.

Types:- The two types of Flow Nozzles are

(a) ISA Nozzle

(b) Long Radius Nozzle

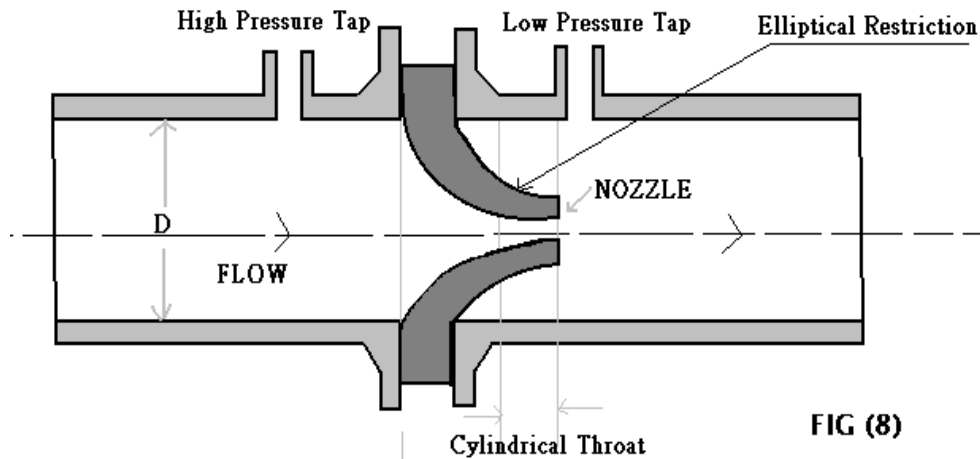

FIG (8)

FLOW NOZZLE

Convergent Inlet
Fig 3.6 Flow Nozzle

www.binils.com

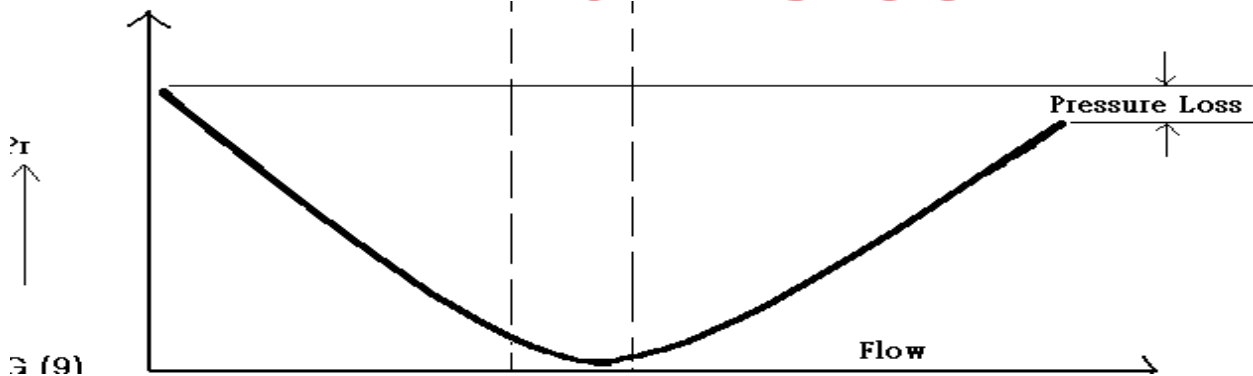

Fig 3.7 Pressure variation of Flow Nozzle

Materials Used:- It is made up of materials such as **Stainless Steel** or **Chrome-moldy steel**.

Applications: Used in steam flow of high temperature.

ADVANTAGES:-

1. Permanent pressure loss lower than Orifice plate.
2. Used for high pressure and temperature steam flow.

LIMITATIONS:-

1. Cost is higher than orifice plate.
2. Limited to moderate pipe sizes.
3. It is necessary to remove a section of pipe to inspect or install it.

VARIOUS COMMERCIAL CONFIGURATION OF FLOW NOZZLE:-

- (1). Flange Type
- (2) Holding Ring Type
- (3) Weld-in Type
- (4) Throat Type

9.3) ORIFICE PLATE

It acts as a primary device. The orifice plate restricts the flow of a fluid to produce a differential pressure across the plate. The result is a high pressure upstream and a low pressure downstream that is proportional to the square of the flow velocity. Orifice plate usually produces greater pressure loss than other primary devices. A practical advantage is cost which does not increase significantly with the pipe size.

The important term used in the orifice plate is **Diameter ratio**

$$d/D = \text{dia of the orifice of the primary element / upstream dia of the pipe}$$

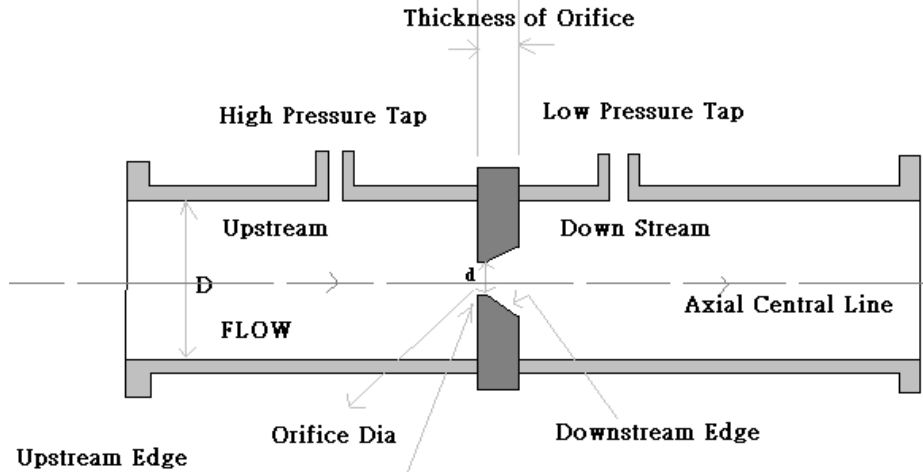

Fig 3.8 Orifice Plate Flow Meter

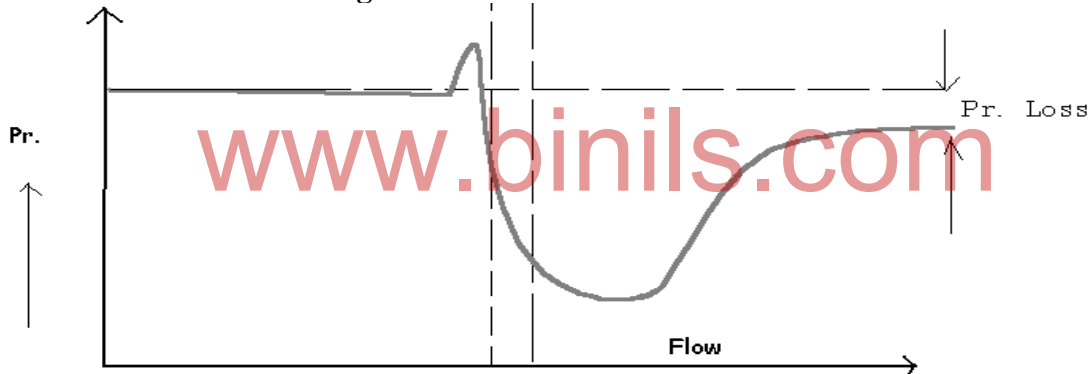

Fig 3.9 Pressure variation of Orifice Plate

Standard Design Of Orifice Plate:-The two standard design of orifice plate are

- (a) Sharp Square Edge Orifice Plate.
- (b) Thin Orifice Plate.

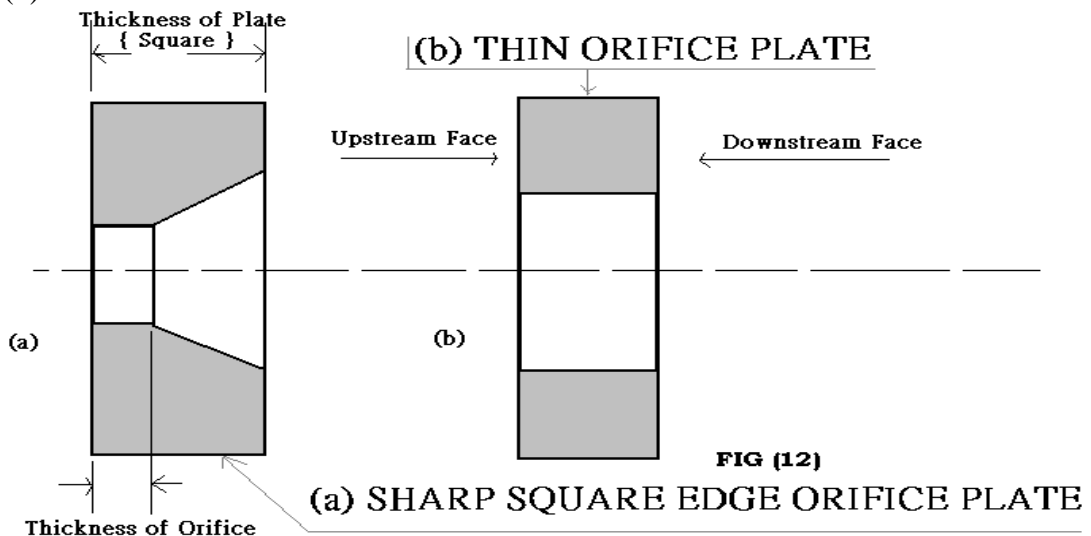

Fig 3.10 Sharp square edge and Thin Orifice Plate

TYPES OF ORIFICE PLATES:-

- (a) Concentric orifice plate
- (b) Eccentric orifice plate
- (c) Segmental orifice plate
- (d) Quadrant edge orifice plate

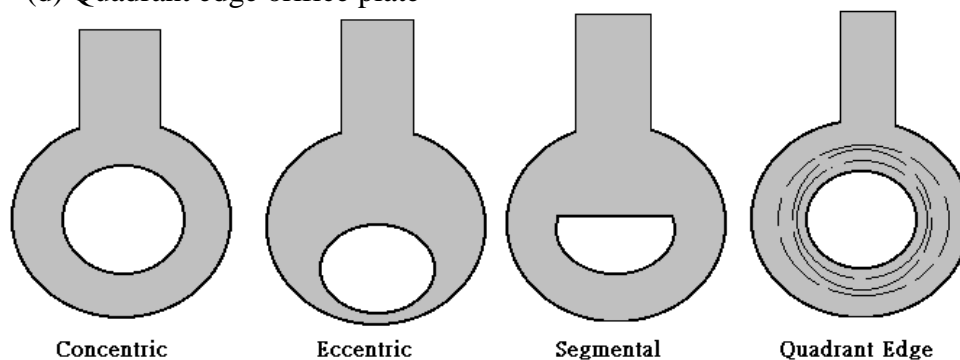

Fig 3.11 Types of Orifice Plates

(a) Concentric Orifice Plate:-

A Concentric, sharp-edged orifice plate is the simplest and least expensive of the head meters. It is usually made of **Stainless Steel (S.S)**. Its thickness varies from 3.175 mm to 12.7 mm depending on pipe line size and flow velocity. It has a circular hole in the middle. It is also made up of materials like Nickel, Chromel, Phosphor bronze etc. to withstand corrosive effects of the fluid.

(b) Eccentric Orifice Plate:-

It is similar to concentric plate except for the offset hole, which is bored tangential to a circle. Location of the bore prevents accumulation of solid materials or foreign particles and makes it useful for measuring fluids containing solids.

(c) Segmental Orifice Plate:-

This is used for the same type of services as the eccentric orifice plate. It has a hole, which is a segment of a circle. It is installed in such a way that the curved section of the opening coincide with the lower surface of the pipe.

(d) Quadrant Edge Orifice Plate:-

This type is used for flow such as crude, slurries and viscous flows. It is constructed in such that the edge is rounded to form a quarter circle. The plate has a concentric opening with a rounded upstream edge rather than sharp.

ADVANTAGES:-

1. Low cost
2. Can be used in wide range of pipe size.
3. Available in many materials.
4. Well-known characteristics.

LIMITATIONS:-

1. Causes relatively high-pressure loss.
2. Tend to clog, thus reducing use in slurry services.
3. Accuracy depends on care during installation.
4. Changing characteristics because of erosion and corrosion.

9.4) DAHL TUBE

It is another restriction type primary element for flow measurement. It is a modified form of Venturi Tube. It consists of a two cones, with relatively large cone angle. A circumferential slot located between the two smaller diameters of the cones forms the **Throat**. The differential pressure produced by Dahl tube is much higher to that of Venturi or Flow Nozzle having the same upstream and throat diameters with the same net head loss. It causes only very low-pressure loss comparing other differential pressure flow elements.

TYPES OF DAHL TUBE:- Dahl tube differs in method of construction to suit particular appliances.

- The types are: -1. Linear Type Dahl Tube
 2. Contour Type Dahl Tube
 3. Fabricated Dahl Tube
 4. Sewage Dahl Tube
 5. Dahl Short Insert
 6. Dahl Long Insert

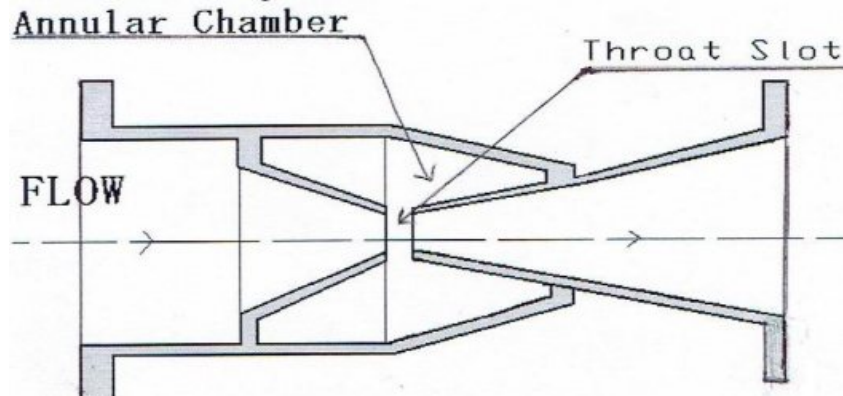

Fig 3.12 Dahl Tube

ADVANTAGES:-

1. Low Pressure Loss
2. Short Length

LIMITATIONS:-

1. Straighter pipe required in the approach pipe length.
2. Pressure difference is sensitive to upstream disturbance.

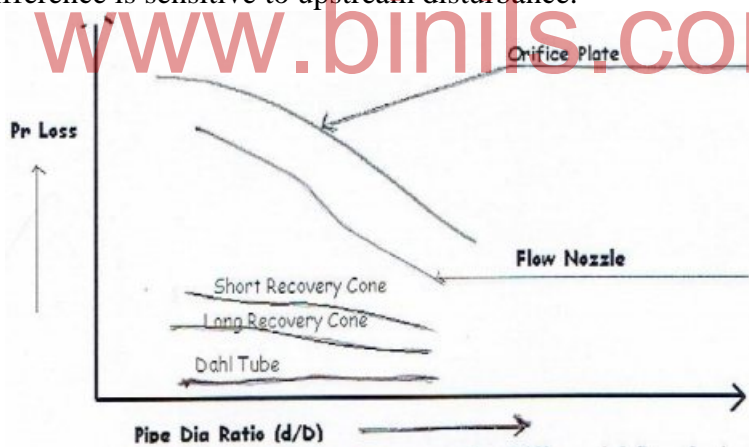

Fig 3.13 Comparison of Pressure losses for Differential flow devices

9.5) PITOT TUBE:-

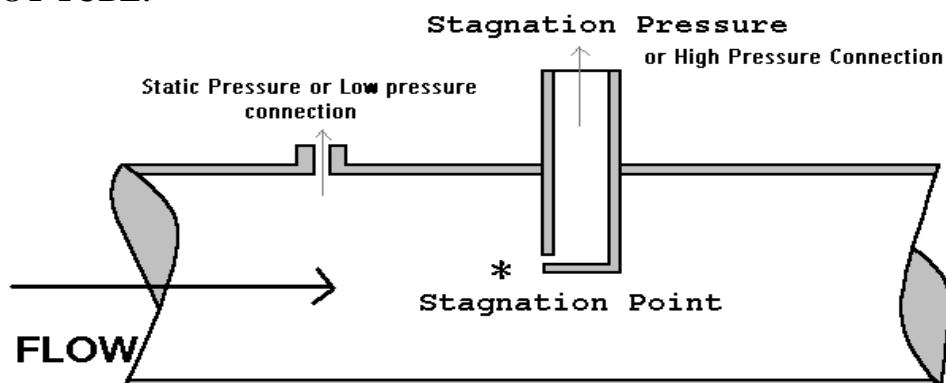

Fig 3.14 Single Tip Flow Tube

It is a fluid velocity-measuring instrument but it can be used for the flow measurement of liquids and gases.

PRINCIPLE: -

The operating principle of Pitot tube is when a solid body is kept centrally and stationary in a pipeline with a fluid streaming down; the velocity of the fluid starts reducing due to the presence of the body. The velocity is reduced to zero directly in front of the body; this point is known as **Stagnation Point**.

By measuring the difference between pressures at normal flow line (Static Pressure) and Stagnation Point (Stagnation Pressure), the fluid velocity is determined.

CONSTRUCTION & WORKING:-

It consists of two hollow tubes that sense the pressure at different places within the pipe. These hollow tubes can be mounted separately in a pipe or installing together in one casing as a single device. One tube measures the Stagnation Pressure and another tube measure the Static Pressure at the wall of the pipe.

Installation of Pitot tube involves determining the location of maximum velocity with pipe traverses. For an accurate measurement, the Pitot tube is moved across the entire dia of the pipe to measure the velocity at several points and then the true average velocity at several points is calculated.

Accuracy: - The accuracy of a Pitot tube range from $\pm 1/2\%$ to $\pm 5\%$.

Applications:- Pitot tube is used in utility streams where high accuracy is not necessary.

LIMITATIONS:-

1. Pitot Tubes have found limited application in industries because they can easily plugged with foreign material present in the fluid.
2. Change in velocity profile develops a very low differential pressure, which is difficult to measure.

COMBINED PITOT TUBE:-

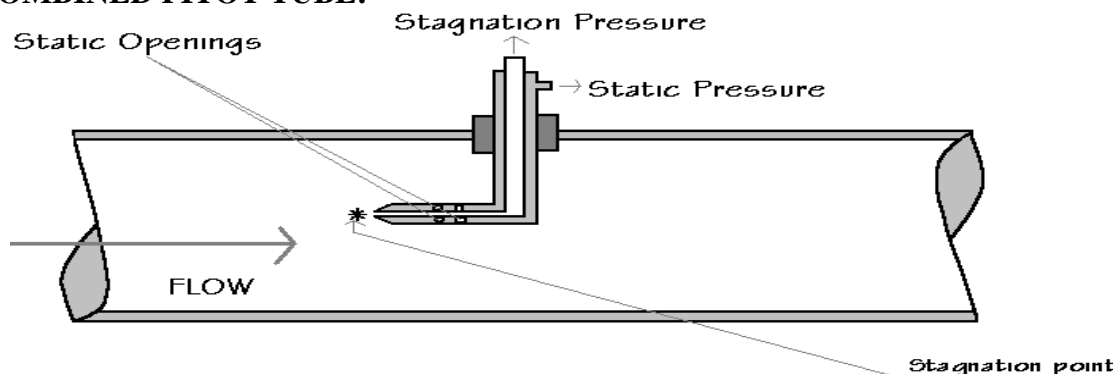

Fig 3.15 Combined Pitot Tube

In Combined Pitot Tube both the hollow tubes installed together in one casing as a single device. The inner tube has the impact opening to measure the Stagnation Pressure while the outer tube has one or more holes on the side for measuring the Static Pressure.

DOUBLE TIP PITOT TUBE:-

Double Tip Pitot tubes are also available in which differential head produced is nearly doubled. In this case two orifices are formed which are diametrically opposite to each other. The connections from the two orifices are separately taken to the manometer tube through two separate holes formed inside the Pitot tube. This tube inserted into the stream with one

orifice facing upstream and the other facing downstream. In this case, Static Pressure connection is not required

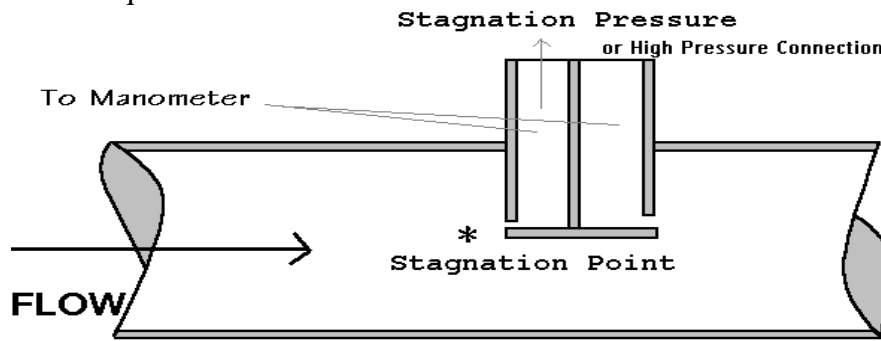

Fig 3.16 Double Tip Pitot Tube

ADVANTAGES OF PITOT TUBE:-

1. Economical to install
2. Some type can be easily removed from the pipeline.

LIMITATIONS OF PITOT TUBE:-

1. Poor accuracy.
2. Not suitable for dirty or sticky fluids.

NOTE:-

ADVANTAGES OF DIFFERENTIAL PRESSURE TYPE FLOW METER:-

1. Low Cost.
2. Easily installed or replaced.
3. No Moving parts.
4. Suitable for most gases and liquids.
5. Available in wide range of sizes.

LIMITATIONS OF DIFFERENTIAL PRESSURE TYPE FLOW METER:-

1. Square root relationship.
2. High permanent pressure losses.
3. Low Accuracy.
4. Flow Rangeability is 4:1
5. Accuracy affected by damage of the Primary flow element due to corrosive fluids.

10. POSITIVE DISPLACEMENT TYPE FLOW METER

PRINCIPLE:-

It measures the volume flow rate (Q) directly by repeatedly trapping a sample of the fluid. **The total volume of the liquid passing through the meter in a given period of time = Volume of samples x Number of samples.**

It frequently totalize flow directly on an integral counter and also it can generate a pulse output which may be read on a local display counter or transmitted to a control room. Each pulse represents a discrete volume of fluid; they are ideally suited for automatic batching system.

It gives excellent accuracy and repeatability. They are normally limited to higher viscosity fluids. With very low viscosity liquids, this meter is less accurate because there is more leakage in the internal sealing surfaces.

TYPES OF POSITIVE DISPLACEMENT METERS:-

The common types are:

1. Nutating Disc Type
2. Oscillating Piston Type
3. Oval Gear Type

ADVANTAGES OF POSITIVE DISPLACEMENT METERS:-

1. Good Accuracy and Rangeability.
2. Very good repeatability.
3. Accuracy not affected by upstream conditions.
4. Suitable for high viscosity fluids.
5. Read out directly in volumetric units.

LIMITATIONS OF POSITIVE DISPLACEMENT METERS:-

1. Regular Maintenance is required.
2. Moving parts subjected to wear.
3. Not suitable for dirty or abrasive liquids.
4. Expensive, Particularly with large diameters.

10.1) NUTATING DISC TYPE

Nutating disc meter is used extensively for residential water services measurement and it can be used in many industrial applications.

The water enters at left side of the eccentrically mounted disc. The disc is pivoted at the geometric center and is allowed to wobble in a specially designed chamber. When the disc rolls, it generates a cone with the apex at geometric center. The liquid pressure sets the disc in motion and as a result the quantity of liquid that enters the left side chamber will be rolled out through the outlet. Each completed cycle of Nutation of the disc will be counted by the counter mechanism, which can be directly calibrated in terms of the volume of the liquid received or discharged. The movement of the disc is transmitted by the gear train to the totalizing register.

Application: - This method is used in **Home water meters.**

Accuracy:- Accuracy is about $\pm 1\%$

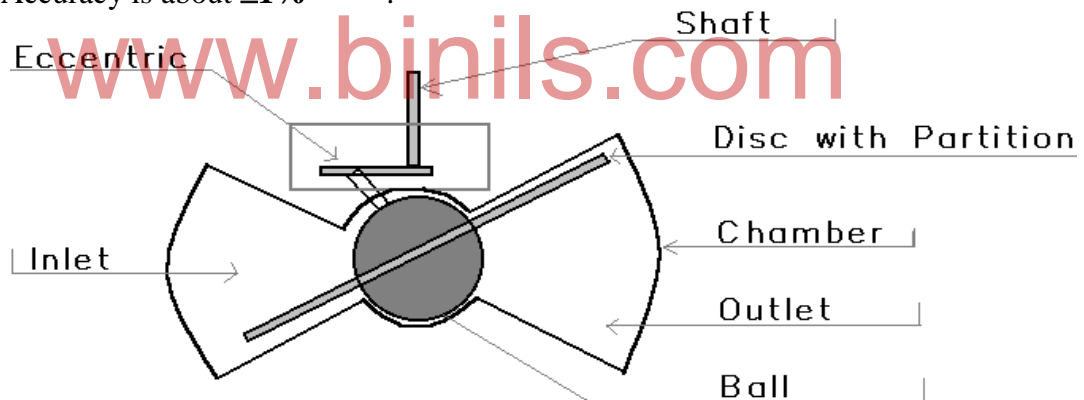

Fig 3.17 Nutating Disc Meter

ADVANTAGES:-

1. Relatively low cost.
2. Applicable to automatic liquid batching system.
3. Several Materials of construction.

LIMITATIONS:-

1. It is limited to pipe size and capacity.
2. Clean fluids can only be measured.

10.2) OSCILLATING PISTON METER

PRINCIPLE:-

The oscillating piston meter is similar to Nutating disc meter except that the measurement device is a **split ring that oscillates in one plane only**. It consists of a slotted cylinder that separates inlet and the outlet part.

CONSTRUCTION & WORKING:-

It consists of a slotted cylinder that separates inlet and the outlet part. The figure shows the Operational Cycle of the meter. The measurement starts with Position 1 where the piston is in neutral position. Fluid enters through the inlet port into the chamber and forces the piston to the left side causes it to roll downward (counter-clockwise) as in Position 2. At Position 2 most of the piston surface is under the influence of incoming fluid and is driven vertically downward as in Position 3 and the liquid enters the space between the inner chamber and the inside wall of the piston. The rotation of the piston is transmitted through a gear train and register

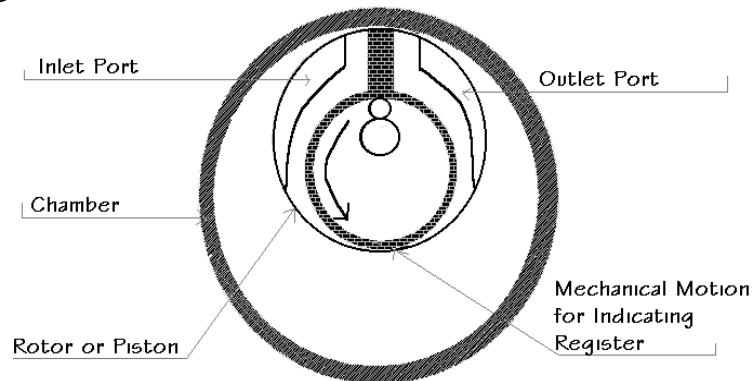

Fig 3.18 Oscillating Piston Meter Position 1

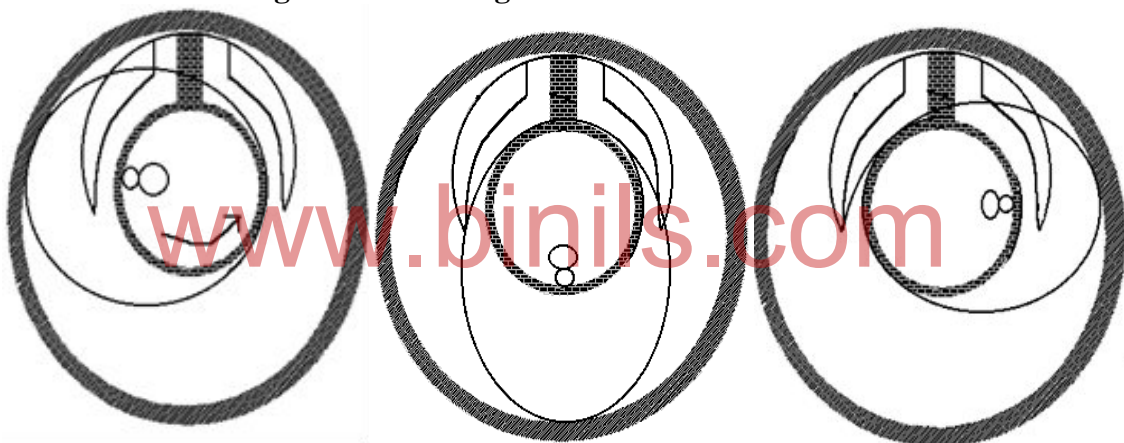

Fig 3.19 Oscillating Piston Meter Position 2,3&4

Applications: - This type of meter in addition to residential water purposes has the capacity to handle clean viscous and corrosive liquid.

Accuracy: - Accuracy is $\pm 1\%$

ADVANTAGES:-

1. Can be easily used in automatic liquid batching system.
2. Easy to install and maintain.
3. Good accuracy especially at low flow rates.
4. Moderate cost.

LIMITATIONS:-

1. Available only in small sizes (Normally 50 mm or less)
2. Clean fluids must be used.
3. Moving parts subjected to wear.

QUESTIONS

Part A

1. Define Reynolds number.
2. Name the types of flow.
3. What is laminar flow?

4. What is turbulent flow?
5. State Bernoulli's Theorem.
6. What is inferential flow meter?
7. List out the various Differential pressure flow meters.
8. State the relationship between flow rate and pressure drop in a Differential pressure flow meter?
9. Name the types of Orifice Plates.
10. Mention any two devices to create the Differential Pressure.
11. State the working principle of Positive Displacement meter
12. List out the types of Positive displacement flow meter.

Part B

1. Define Laminar Flow and Turbulent Flow.
2. Sketch Differential pressure Flow meter in detail.
3. Write short notes on Primary and Secondary devices of Differential pressure Flow meters.
4. Sketch Venturi tube in detail.
5. List and draw the types of Orifice Plates.
6. Write short notes on Pitot tube.
7. Mention the advantages and limitations of Differential Pressure Flow meter.
8. Briefly discuss the operation of Nutating disc meter.
9. Mention the advantages and limitations of Positive Displacement meter.

Part C

1. Explain Orifice Plate in detail with a neat sketch.
2. Sketch and explain Venturi tube in detail.
3. Explain the principle and working of Flow nozzle with a neat sketch.
4. Describe about the principle and working of Dahl tube with a neat diagram.
5. In detail explain Pitot tube with a neat sketch..
6. Explain the principle and working of Oscillating Piston meter with a neat sketch.
7. What is positive displacement type flow meter? With a neat sketch explain any one method.

UNIT IV MEASUREMENT OF FLOW (ELECTRICAL)

1. ELECTROMAGNETIC FLOW METER

The magnetic flow meter represents one of the most flexible and universally applicable flow measurement systems available today. Electromagnetic flow meter is also known as **Magnmeter**. It is ideally suited for measuring harsh chemicals, slurries and other fluids with solids in suspension and also other extremely difficult fluids. Electromagnetic flow meter works on the principle of **Faraday's law of Electromagnetic Induction**.

PRINCIPLE:-

The Faraday's law of Electromagnetic Induction states that when moving a conductive material at a right angle through a magnetic field, a voltage is induced proportional to velocity of conductor. [In this case, conductor is Fluid]

The magnitude of the induced voltage (E) is directly proportional to (i) Velocity of the conductor fluid (V) (ii) width of the conductor (D) (iii) Strength of Magnetic field (B).

$$E = KVDB$$

To convert the velocity measurement into Volumetric flow rate the eqn Is

$$Q = VA$$

Q = volumetric flow rate

V = fluid velocity

A = Cross section area of flow meter

From the above,

$$E = KVDB$$

$$E = K \cdot Q/A \cdot DB$$

$$\text{Hence } Q = E \cdot A / KDB = Z \cdot E$$

$$\text{Where } Z = A / KDB = \text{a constant}$$

Therefore the induced voltage is directly proportional and also linear with volumetric flow rate.

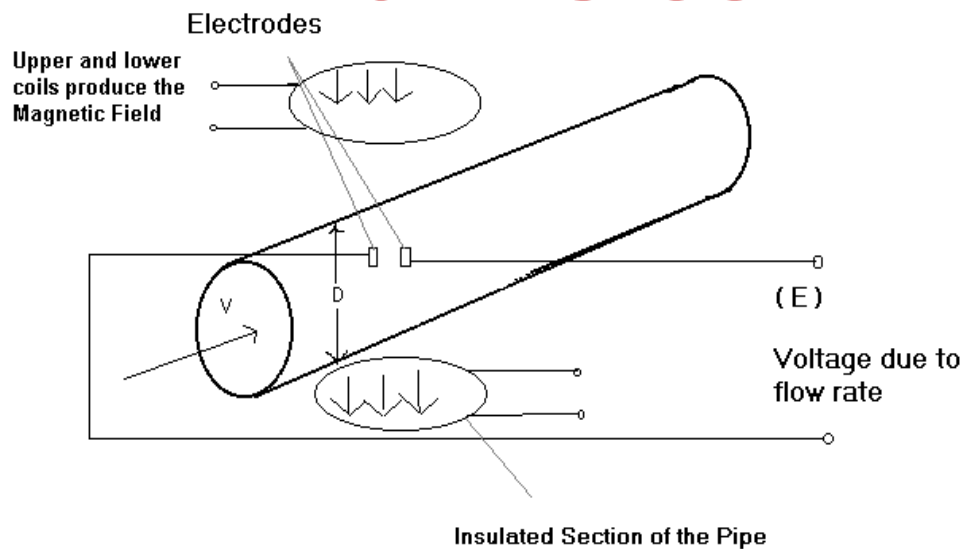

Fig 4.1 Electromagnetic Flow meter

CONSTRUCTION:-

The magnetic flow meter consists of an electrically insulated or non-conducting pipe such as fiberglass with a pair of electrodes mounted opposite to each other. The two electrodes are Point Type made of Stainless Steel or Platinum where high resistance to corrosion is necessary. The magnetic coils are mounted around the pipe so that magnetic field is generated in a plane mutually perpendicular to the axis of the flow meter body and to the plane of the electrodes. Either AC or DC voltage may energize the magnetic coils, but the

recent development is Pulsed DC type. The pulsed DC type in which the magnetic coils are periodically energized with a low freq. Square wave.

WORKING:-

As the liquid passes through the pipe section, it passes through the magnetic field set up by the magnet coils, thus inducing voltage in the liquid, which is detected by the pair of electrodes mounted in the pipe wall. In this the flowing liquid acts as a conductor. The only major limitation is the fluid must be **electrically conductive** and **Non-Magnetic**.

An Insulator pipe is chosen for avoiding short-circuits and non-magnetic pipe is selected for allowing magnetic field to penetrate into the liquid.

ADVANTAGES OF ELECTROMAGNETIC FLOW METERS:-

1. Obstruction less flow.
2. Measurements unaffected by temp, Pressure, Viscosity & Density.
3. Good Accuracy in range of $\pm\frac{1}{2}$ to ± 2 %
4. Suitable for slurries, corrosive and abrasive liquid.
5. Wide Rangeability of **30:1**
6. Can be used as bi-directional meter

LIMITATIONS OF ELECTROMAGNETIC FLOW METERS:-

1. Liquid must be electrically conductive.
2. Not suitable for gases.
3. Relatively expensive.
4. Must be full at all times.

2. ULTRASONIC FLOW METER:-

Ultrasonic flow meter employs high frequency sound waves in two different ways to measure the velocity of the fluid in a pipe.

PRINCIPLE:-

The Ultrasonic flow meters are based on the principle of the apparent change in the velocity of propagation of sound waves in a fluid with change in velocity of flow of the fluid. In the both types mentioned above, a piezoelectric crystal is excited by electrical energy at its mechanical resonance, thus emitting a sound wave, which travels at the speed of sound in the medium, which is used to infer the flow rate. The crystal is placed in contact with the fluid Inserted Transducer or else mounted outside the piping (clamp on Transducer).

TYPES:-

The two types of Ultrasonic Flow meters are:

- (a) **Transit time or Time of flight (TOF) Flow meter.**
- (b) **Doppler Ultrasonic Flow meter.**

(a) TRANSIT TIME (or) TIME OF FLIGHT (TOF) ULTRASONIC FLOW METER:-

PRINCIPLE:-

These device measure flows by measuring the time taken for ultrasonic wave to transverse a pipe section, both with and against the flow of liquid within the pipe. In this, a transmitter beams a high frequency (1 MHz) to form a fixed cross-angle with the pipe axis. The transit time employed by the wave to reach a receiver placed on the opposite pipe wall depends on both the velocity of sound in the fluid and whether the wave is moving with or against the flow.

In the process field, the speed of sound in a fluid is not only unknown, but also vary with fluid state properties such as temp and density. In order to avoid this effect, two series of sonic pulses with known travel frequency are employed.

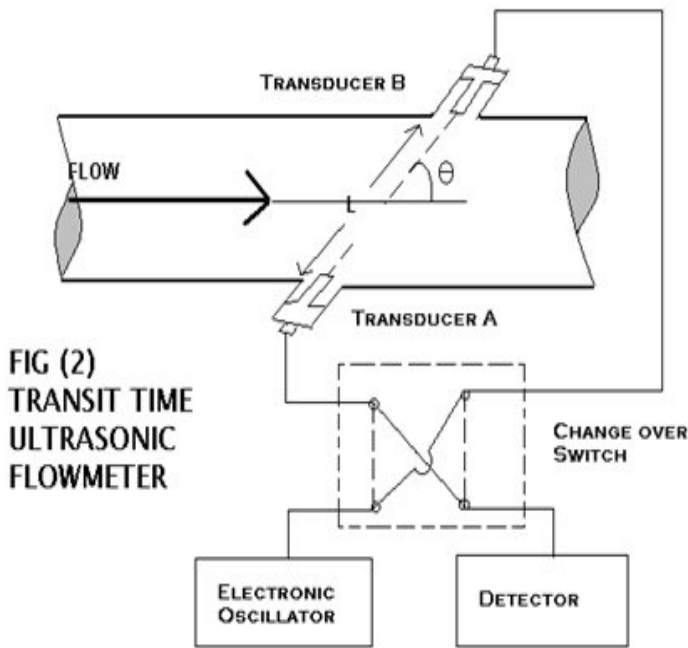

FIG (2)
TRANSIT TIME
ULTRASONIC
FLOWMETER

CONSTRUCTION & WORKING:-

The transit time flow meter consists of two transducer A & B inserted into the pipeline and working both as Transmitter and Receiver as in figure. Ultrasonic wave are transmitted from Transducer A to Transducer B & vice versa. An Electronic oscillator is connected to supply ultrasonic waves alternately to A or B which is working as Transmitter through a changeover switch. And also the detector is connected simultaneously to B or A which works as a receiver. The detector measures the transit time from upstream to downstream transducers and vice versa.

Fig 4.2 Transit Time Ultrasonic Flow meter

The time T_{ab} for Ultrasonic wave to travel from Transducer A to Transducer b is

$$T_{ab} = L / C + V \cdot \cos \theta$$

The Time T_{ba} to travel from Transducer B to Transducer A is

$$T_{ba} = L / C - V \cdot \cos \theta$$

L = Acoustic path length between Transducer A & B

C = Velocity of sound in the fluid.

θ = angle of path w.r.t pipe axis.

V = Velocity of fluid in the pipe.

Hence the Time difference between T_{ab} and T_{ba} is

$$\Delta T = T_{ab} - T_{ba}$$

$$\Delta T = 2LV \cos \theta / C$$

$$\text{Hence } V = \frac{\Delta T \cdot C}{2L \cos \theta}$$

LIMITATIONS:-

1. This is generally used in clean liquid applications where the ultrasonic beam is not attenuated or continually interrupted by fluid particles.

(b) DOPPLER ULTRASONIC FLOW METER:-

PRINCIPLE:-

This is based on the well-known **Doppler Effect**. When a constant frequency sound wave is transmitted into the fluid, some energy is scattered back by solid particles or air bubbles entrained in the flow because of the moving particles. Therefore the frequency of the reflected sound wave differs from the original frequency by an amount proportional to the fluid velocity.

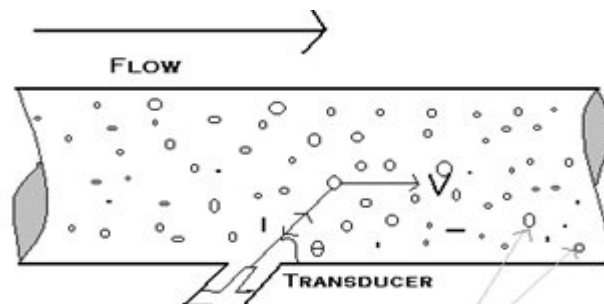

Fig 4.3 Doppler Ultrasonic Flow Meter

CONSTRUCTION & WORKING:-

In Doppler flow meter, an ultrasonic wave is projected at an angle through the pipe wall into the liquid by a transducer mounted outside the pipe. Part of the ultrasonic wave is reflected by bubbles or particles in the liquid and is returned through the pipe to the transducer. Since the reflector (bubbles) is traveling at the fluid velocity the frequency of the reflected wave is shifted according to Doppler principle.

The velocity of the fluid is given by , $V = \frac{\Delta f \cdot Ct}{2 f_0 \cos \theta} = \Delta f k$

$$k = Ct / 2 f_0 \cos \theta$$

Δf = difference between transmitter & receiver frequency

Ct = Velocity of sound in the transducer

f_0 = frequency of transmission

θ = Angle of Transmitter & Receiver w.r.t pipe axis

k = constant

ADVANTAGES OF ULTRASONIC FLOW METER:-

1. Obstruction less
2. Rangeability is **10:1**
3. Easy to install especially clamp on Version
4. Flow measurement is bi-directional
5. No moving parts

LIMITATIONS OF ULTRASONIC FLOW METER:-

1. Maximum Temperature 150°C
2. Particular Fluid conditions are required.
Transmit type:- clean liquid
Doppler type:- particles or impurities in the stream
3. Not very high accuracy (about $\pm 2\%$)

3. SWIRL FLOW METER:-

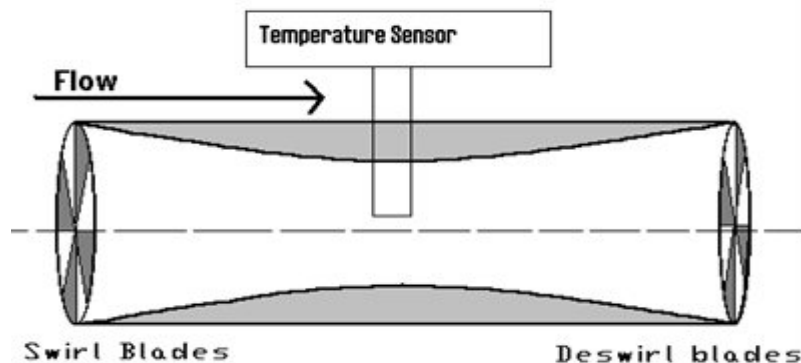

Fig 4.4 Swirl Flow Meter

The Swirl meter operates similar to the principle of Vortex Flow meter. The Fig shows the construction of Swirl Flow meter. It consists of a fixed set of Swirl blades made of stainless steel. The swirl blades introduce spinning or swirling motion to the fluid at the inlet. At the downstream of the Swirl blades, there is a Venturi like construction and expansion of the flow passage. A temperature sensor (Thermistor) is placed in the downstream of the blades, which is heated by a constant electric current. At the exit of the meter de-swirl blades are fixed to straighten out the flow leaving the meter. And also the purpose of using de-swirl blades is to isolate the meter from downstream piping effects.

As the fluid, passes through the fixed set of Swirl blades at the inlet, a swirling or spinning motion is introduced in the area where expansion occurs; the swirling flow oscillates at a frequency proportional to fluid flow rate. This oscillation of the fluid causes variation in temperature of the temperature sensor due to change in resistance.

The amount of heat extracted from the Thermistor by passing fluid depends on the fluid velocity. Consequently, each high velocity vortex passes the Thermistor, changes the resistance, since a constant current is applied.

Applications:- It is primarily used in gaseous applications.

Repeatability:- $\pm 0.25\%$

4. VORTEX FLOW METER

PRINCIPLE:-

A common type of velocity meter is the **oscillatory meter**, which causes the fluid to oscillate in a regular manner; the frequency of oscillation is proportional to the flow rate. The most popular of these is the **vortex shedding meter**.

A non-streamlined obstruction or bluff body in a pipeline causes the formation of swirls called vortices behind the body. The frequency at which the vortices are shed is proportional to the velocity of the fluid.

CONSTRUCTION & WORKING:-

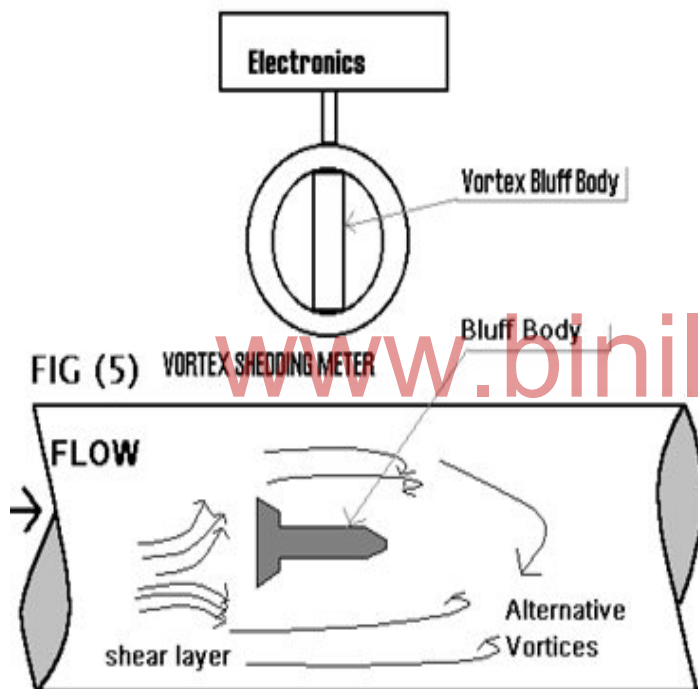

Fig 4.5 Vortex Shedding Principle

$$f = N_{st} \cdot V / d$$

V = fluid velocity

d = characteristic dimension of shedding body

N_{st} = Strouhal No.

f = shedding frequency

The operation of the vortex shedding flow meter is based on the phenomenon known as **vortex shedding** which occurs when the liquid or gas flows around a non-Streamlined object known as bluff body. When the fluid flows through an obstruction, boundary layers of slow moving fluid are formed along the outer surfaces of the obstacle. So, the flow is unable to follow the obstacles on its downstream side.

The low pressure area which forms behind the object detaches the separated flow layers from the main stream of the fluid and **rolls themselves into eddies or vortices** in the low pressure area. The frequency at which the vortices are formed is directly proportional to the fluid velocity.

As the vortex is shed from one side of the bluff body, the fluid velocity on that side increases and the pressure decreased and at the same time the velocity on the opposite side decreases and pressure increases. As the next vortex is shed from the opposite side of the bluff body, the entire effect is reversed.

Piezo electric crystals or Strain gauge are used for detecting the alternate forces causes on the shedder. This meter is not recommended for fluids having viscosities higher than 30 cp (centipoises).and also pipe Reynolds no. R_D to maintain above 10,000.

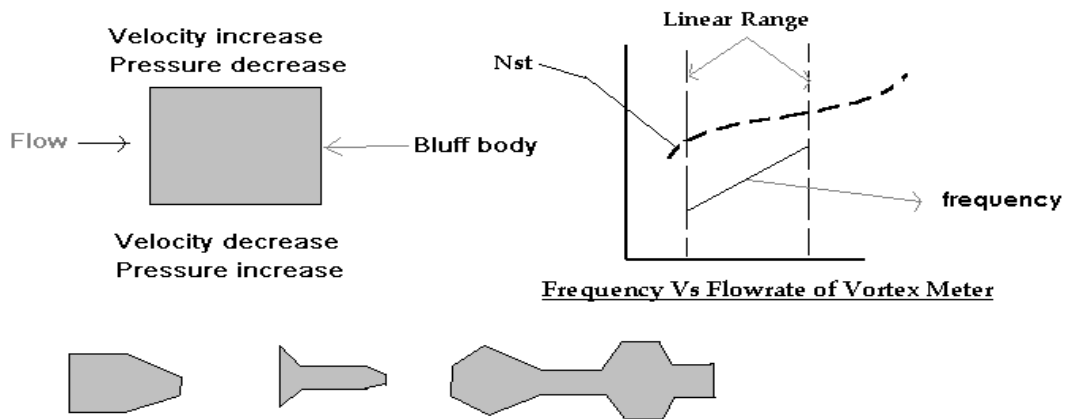

Fig 4.6 Various Shedder Shapes

ADVANTAGES:-

1. Wide Rangeability **25: 1**
2. Good Accuracy ± 0.5 to ± 1.5 %
3. Used with liquids, Gases, slurries and steam.
4. Minimum maintenance
5. Good linearity over the working range.

LIMITATIONS:-

1. Not suitable for dirty and abrasive fluids.
2. Straight upstream pipe of 20D and straight downstream pipe of 10D is required.
3. High cost.

5. CROSS CORRELATION FLOW METER

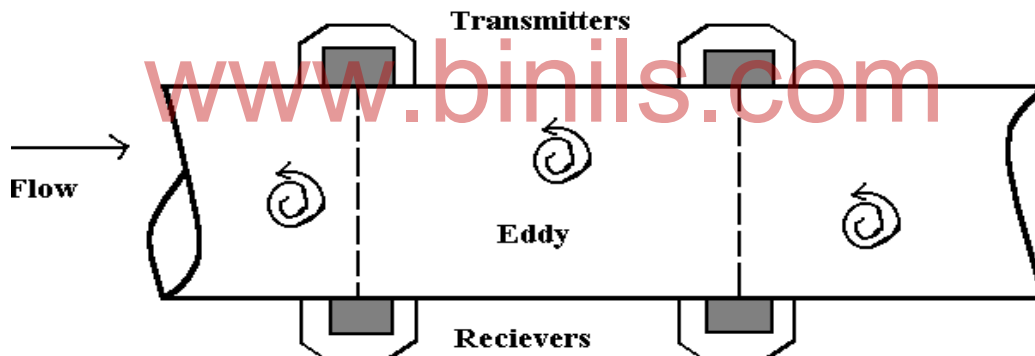

Fig 4.7 Cross Correlation Flow Meter

The Cross-Correlation meter employs two transverse acoustic signals separated by a short distance. Under no-flow or laminar flow conditions, the two signals received are identical to those transmitted. When turbulent flow occurs the movement of an eddy through a beam causes a change in the acoustic signal. This particular eddy will cause an identical change in the second acoustic signal, and the eddy can be tracked as it moves downstream. An electronic signal processor is used to compare the two received signals. When two identical signals are found, the time and distance (between the acoustic transmitter) information is used to compute Pipe diameter. If no eddies are present in the flow, the meter can track sediment or bubbles. However, if the flowing fluid is homogenous and has no eddies (laminar flow), this type of meter will not work. Therefore, the measurement is susceptible to an inaccuracy associated with variations in velocity profiles.

6. MASS FLOW METER

Mass flow meter measures the mass rate of flow directly. The mass flow meter infers the mass flow rate by the arm given below. $Q_m = Q_v \cdot \rho$

$Q_m = \text{Mass flow rate}$

Q_v = Volume flow rate

ρ = density of fluid

Hence the mass flow meters essentially combine two devices one to measure fluid velocity and the other to measure density.

THERMAL MASS FLOW METER

Thermal mass flow meters work on the principle of heat transfer by the fluid flow. It consists of three elements arranged consecutively along the direction of motion. An electric heater is placed between highly accurate temperature sensors installed respectively in the upstream and downstream of the heater. The difference between the two temperature readings is proportional to mass flow rate. Thermal mass flow meters rely on the thermal rather than physical properties of the fluid and therefore widely used with clean and low-density gases.

Applications:- Common applications include duct airflows such as combustion air for boilers and stack gas flows.

TYPES OF THERMAL MASS FLOW METERS:-

The two types of Thermal Mass Flow Meters are

- a. Immersible Type
- b. Capillary Tube type.

(a) IMMERSIBLE TYPE THERMAL MASS FLOW METER:-

(a.1) HEATED GRID FLOW METER:-

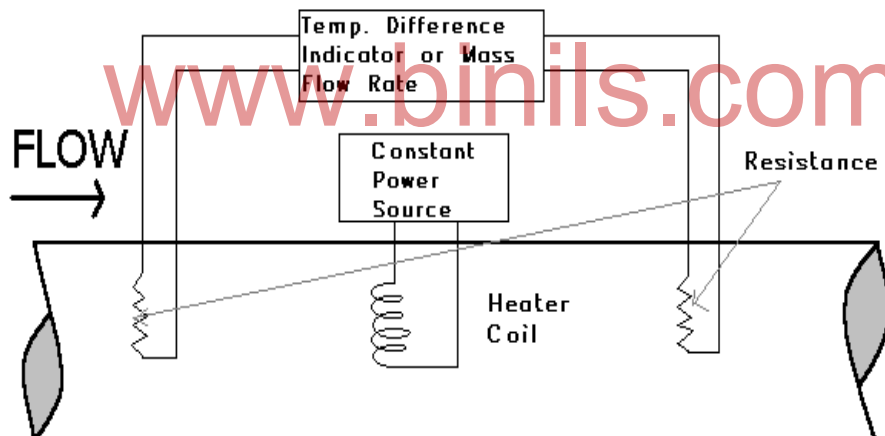

Fig 4.8 Heated Grid Flow Meter

Mass flow can be inferred from the rise in temperature of the fluid stream. The energy required to raise the temperature of the fluid may be between two temp sensors. Heat absorption depends on the heat capacity and mass flow rate.

LIMITATIONS:-

1. Location of the heater directly in the stream.
2. Large power Input required to measure high flow rates.

(a.2) HEATED TUBE THERMAL MASS FLOW METER:-

In this method, a self-heated probe consisting of resistance wires, thermocouples or thermistors is exposed directly to the stream. This retains the inherent mass flow measurement characteristics of the Grid Type flow meter. But it eliminates the heated grid in the flow stream.

It can measure large flow rates with low power inputs. Gases pass through the tube is uniformly heated by means of a transformer. The temperature distribution about the mid-

point is symmetrical at zero flow, so that thermocouples TC-1 and TC-2 cause a null read out. When the gas flows through the tube, the temperature distribution becomes asymmetrical for a constant power input; the differential thermocouple output indicated on the meter is a function of heat capacity and mass flow rate. These devices require relatively low power input and are effective for low flows.

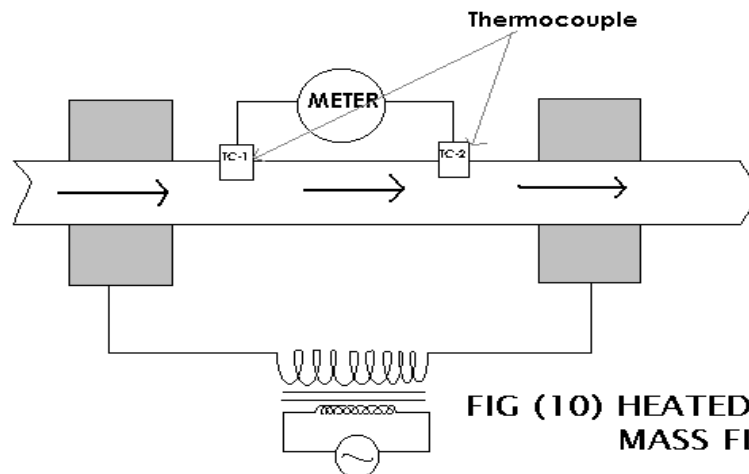

FIG (10) HEATED TUBE THERMAL MASS FLOW METER

Fig 4.9 Heated Tube Thermal Mass Flow Meter

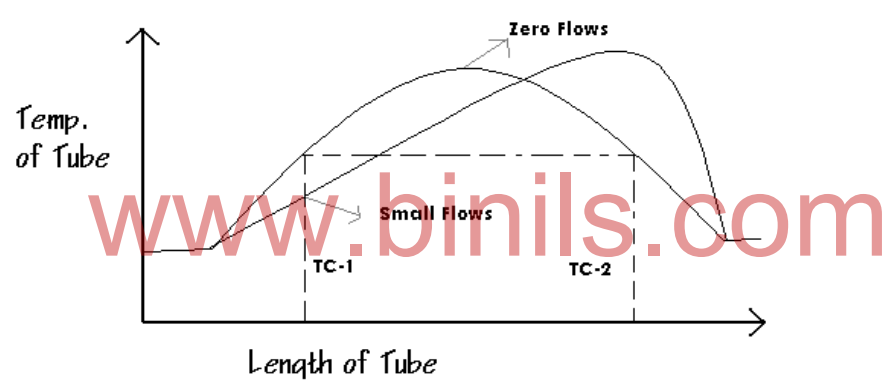

Fig 4.10 Temperature distribution under static and flowing conditions

(b) CAPILLARY TUBE THERMAL MASS FLOW METER:-

For very low mass flow rate of clean liquid and gases this can be used. It consists of extremely heated bypass capillary tube. The main flow enters the capillary tube thermal mass flow meters splits into two paths.

- a. One through the Sensor tube (m1)
- b. Another through the Bypass tube (m2)

Total mass flow is $m = m1 + m2.$

$m = c \cdot m1$

c = flow fraction, (ie) $1 + m2/m1.$

The temperature sensors installed outside the capillary tube sense the variation of temperature distribution along the tube.

In zero flow conditions the temperature distribution is symmetrical. It becomes asymmetrical with the flow. The bypass is realized across laminar element. The laminar flow guarantees the proportionality between the two split flows. Accuracy is $\pm 1\%$. Sensor tube has a relatively small dia and large L/D ratio in the range of 50:1 and a 100:1. L/D ratio is high to create a pure laminar flow in the sensor tube. The bypass is a single machined element with small rectangular passages having a high length to width ratio

The RTD coils sense changes in the temperature through the changes in the resistance. In actual operation, the mass flow carries heat from the upstream coil to the downstream coil;

therefore the latter is hotter than the former. The long length of the sensor capillary tube ensures that the coil heats the entire cross-section of the stream

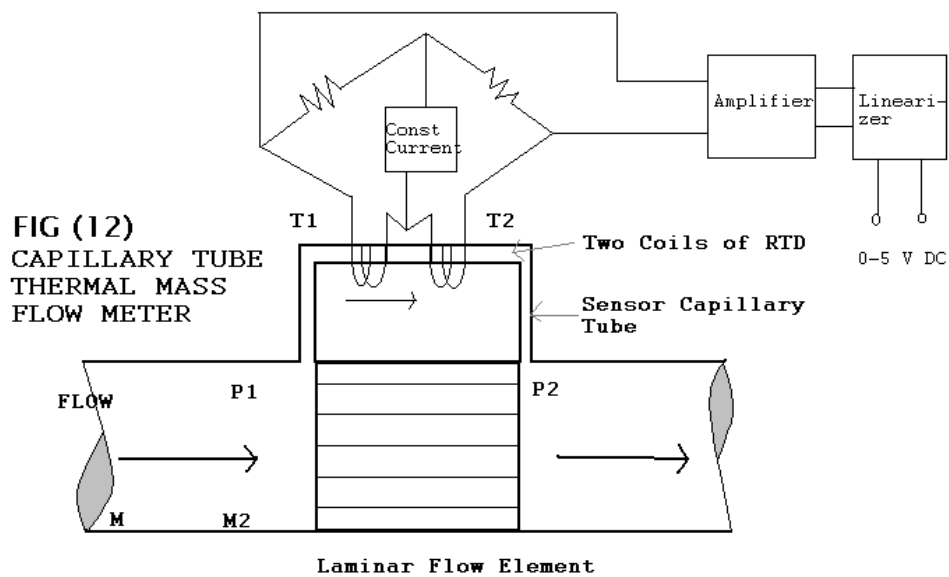

Fig 4.11 Capillary Tube Thermal Mass Flow Meter

ADVANTAGES OF THERMAL MASS FLOW METERS:-

1. No moving parts
2. Rangeability of **50:1**
3. Accuracy of **±1%**
4. Suitable for large pipe size

LIMITATIONS OF THERMAL MASS FLOW METERS:-

1. Energy consumption required
2. Mostly in gas services. (Only rarely liquid services)

7. SOLID FLOW MEASUREMENT

The most common Solid flow measurement occurs when material in the form of small particles such as crushed material or powder is carried by a conveyor belt system or by some other host.

CONVEYOR BELT METHOD:-

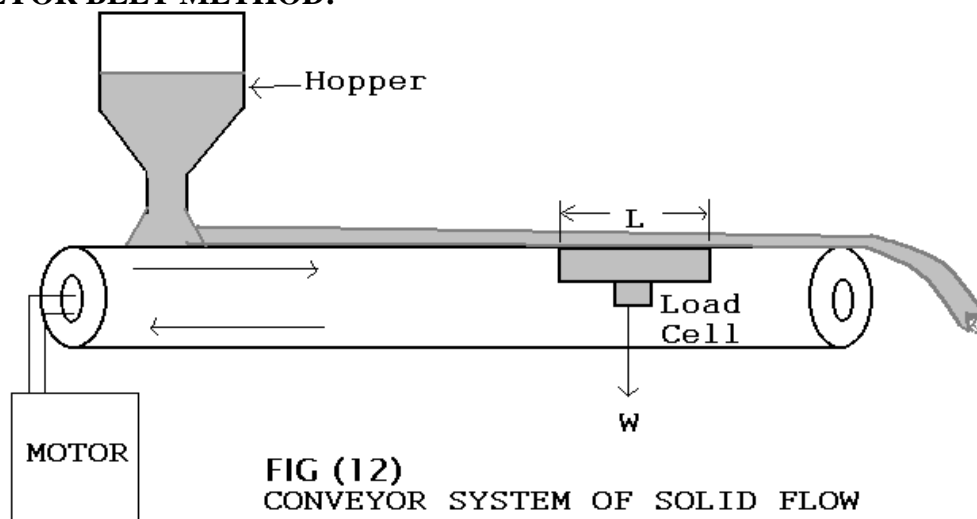

Fig 4.12 Conveyor belt method for Solid flow measurement

For solid objects, the flow usually is described by mass or weight per unit of time, which is being transported by the conveyor system. The unit is kg/min. To measure the flow it is necessary to weight the material for some fixed length of the conveyor. By knowing the

speed of the conveyor system, calculation of the material flow rate can be done. In the figure a typical conveyor system is shown where material is drawn from a hopper and transported by the conveyor system.

Assuming the material can flow freely from the hopper, the faster the conveyor is moved, the faster material will flow from the hopper and greater the material flow rate of the conveyor. The flow rate can be calculated from $Q = WR/L$

Q = flow in Kg/min

W = weight of material in section of length "L"

R = Conveyor speed in m/min

L = Length of weighing platform in 'm'.

In this case, it is evident that the flow transducer is actually the assembly of conveyor, hopper opening and weighing platform

8. TURBINE FLOW METER

PRINCIPLE:-

The turbine flow meter is used for the measurement of liquid gas and very low flow rates. It works on the principle of turbine.

CONSTRUCTION & WORKING:-

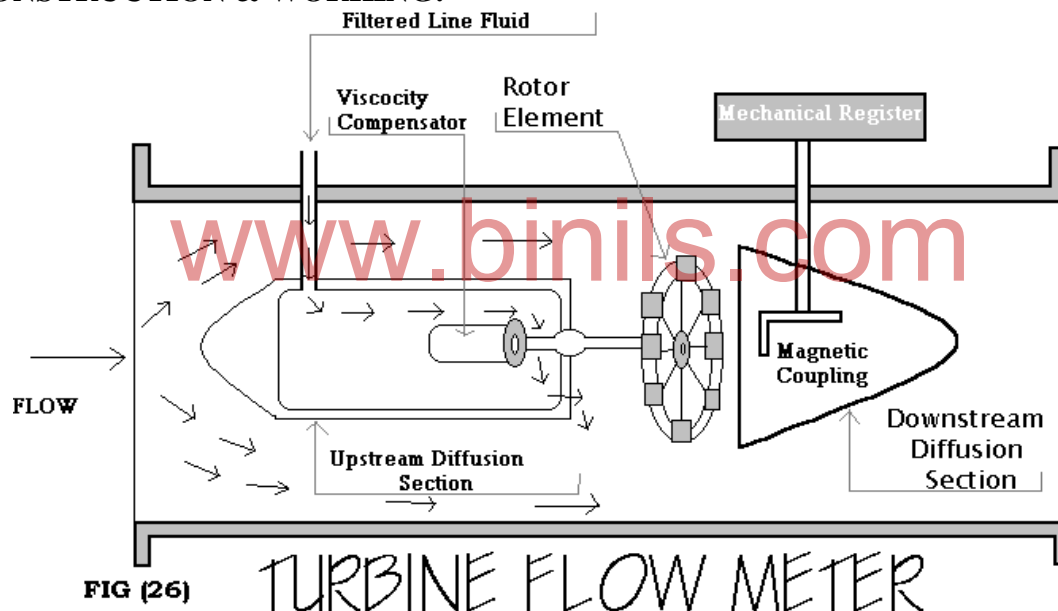

Fig 4.13 Turbine Flow Meter

It consists of a multi-bladed rotor, which is mounted at right angles to the axis of flowing liquids. The rotor is free to rotate about its axis. Any change in viscosity affects the meter accuracy. The incorporated system is known as viscosity compensator that maintains a constant relationship between product flow rate and rotor speed.

The fluid whose volume is to be measured enters the meter and passes around the upstream diffuser through the rotor, causing it to rotate then around the downstream diffuser and out of the meter. Viscosity compensator is housed within the upstream diffuser section. A small portion of the flowing liquid is withdrawn from the upstream of the meter, filtered, and rotated to the viscosity compensator. The filtered liquid passes between the stationary case and the rotating drum, thereby imposing a resistance to rotation of the drum that is directly proportional to the viscosity of the flowing liquid. The sample flow is returned to the main flow upstream of the rotor where it is measured as a part of the total flow.

At steady rotational speed, the speed of the rotor is directly proportional to the fluid velocity and hence to volumetric flow rate.

The speed of the motor is monitored by a magnetic pickup coil. The magnetic pickup coil is mounted in close proximity to the rotor. As each rotor blade passes the magnetic pickup coil, it generates a voltage pulse, which is a measure of the flow rate, and the total pulse gives the measure of the total flow.

The K-factor is given as $K = T_k f / Q$

- K = pulses per volume unit
- T_k = Time constant in minutes
- f = frequency in Hz
- Q = volume flow rate in gpm.

Accuracy: - The accuracy range is from $\pm 1/4 \%$ to $\pm 1/2 \%$.

Applications: - It is used in aerospace and airborne applications for energy-fuel and cryogenic flow measurements.

ADVANTAGES:-

1. High Accuracy
2. Rangeability **10: 1**
3. Very good repeatability
4. Can be compensated for viscosity variations

LIMITATIONS:--

1. Moving parts subjected to wear.
2. Can be damaged by over speeding.
3. High cost.

9. TARGET FLOW METER

The Target meter measures flow by measuring the force on a target or disc. The target is placed centered at right angles to the direction of fluid flow. The fluid flow develops force on target, which is proportional to the square of the flow. The target or disc is mounted on a force bar passing through a flexible seal. This flow meter can be installed directly in the flow line by eliminating the pressure tap connections.

The force bar transmits the force developed on the target or disc to a force transducer, either electronic or pneumatic, to measure the force which is proportional to the square of the flow.

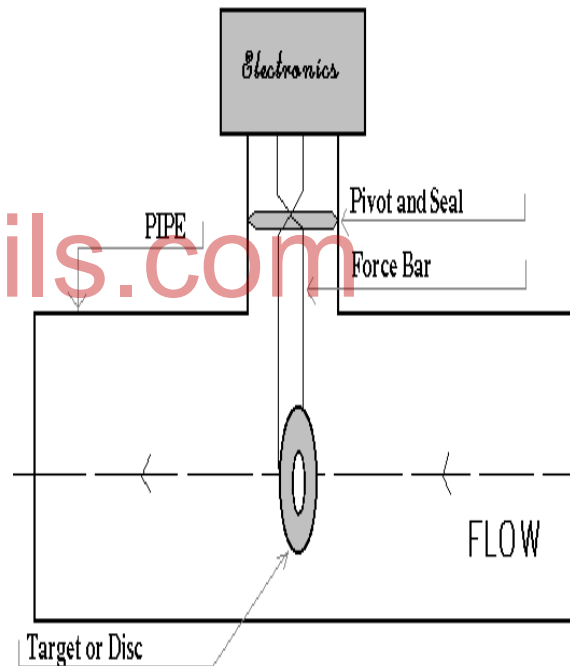

Fig 4.14 Target Flow Meter

The relationship between the flow rate and force is expressed as

$$Q = K\sqrt{F}$$

Q = Flow rate

K = Known coefficient

F = Force.

Force transducer or Bonded Strain Gauges are used for converting force into electrical output signal. In the case of Bonded Strain Gauge, it is used in four active arm bridge circuits to convert force into electrical output, which is proportional to square of rate of flow.

The Target meters are available in sizes from **12 mm to 203 mm pipe dia.** The target discs are available with dia of **0.6 to 0.8 times pipe dia.**

Applications:- It is applied in a number of fields for the measurement of liquids, vapors and gases. It is especially used for measuring heavy viscous dirty or corrosive fluids.

Suitability of force Transducer and Bonded Strain Gauge:-

Transducer	Temperature	Pressure	Accuracy
Force bar	400 °C	100 kg /cm ²	± 0.5%
Bonded Strain Gauge	315 °C	325 kg / cm ²	± 0.5 to 3 %

ADVANTAGES:-

1. Useful for difficult measurements such as slurries and corrosive mixtures etc.
2. Good Repeatability.
3. Good for relatively high temperature and pressure.

LIMITATIONS:-

1. On-line mounting required.
2. Limited calibration data.

10. HOTWIRE ANEMOMETER

PRINCIPLE:-

Hot wire Anemometer is used for the measurement of unsteady flow of gases. When a fluid flows over a heated surface, heat is transferred from the surface to the fluid flow; hence the hot surface temperature reduces. The rate of reduction of temperature is related to flow rate.

CONSTRUCTION & WORKING:-

In this, heat is supplied electrically to a fine wire placed in the flow stream. The temperature of the wire is determined by measuring its resistance with a Wheatstone bridge. The heat loss changes the temperature of the surface that results in change of resistance of the hot wire. Measuring the change in resistance in the circuit, the flow can be found out.

There are two basic techniques of measurement of flow.

- a. Measuring current, keeping the temperature (Resistance) constant
- b. Measuring Resistance, keeping the current constant.

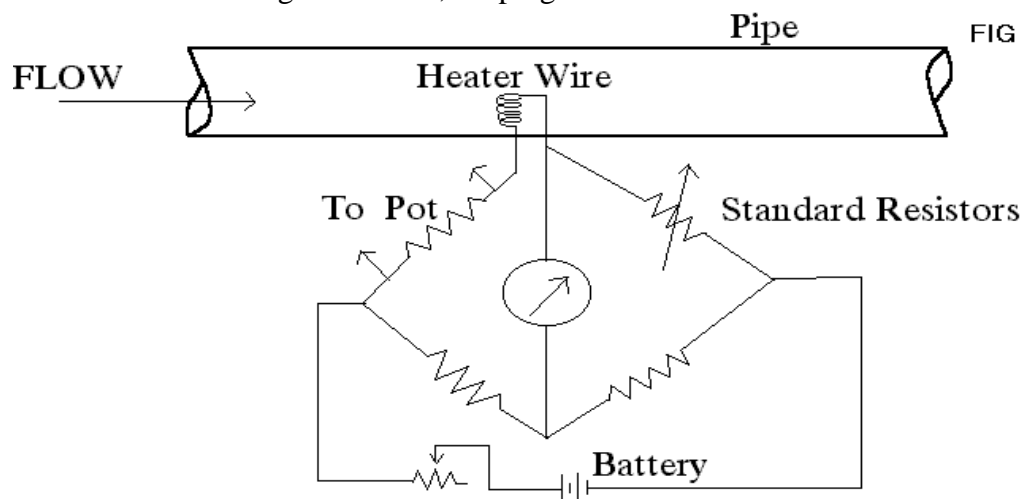

Fig 4.15 Hot wire Anemometer

The first technique, involves adjusting the current through the wire so that the temperature remains constant and measuring the heating current. In this way, the bridge remains always balanced. The current is measured by finding the voltage drop across a standard resistor connected in series with the heating wire. The voltage drop is found by using a potentiometer.

Loss of heat from the heated wire is given by $a(v\rho+b)^{1/2} \text{ J/s}$

V = velocity of heat flow

ρ = density of fluid

a&b = constants depending upon the dimension and physical properties of wire and fluid.

The thermo element is generally made of **platinum wire** having a dia of **0.005 to 0.03 cm**. Tungsten and Nichrome have also been used as the thermo element. The heated wire mounting is to be done under tension in order to avoid sagging due to heating up.

QUESTIONS

Part A

1. State the working principle of Electromagnetic Flow meter.
2. What are the major requirements of Electromagnetic Flow meter to operate?
3. List out the advantages of Electromagnetic Flow meter.
4. Mention the types of Ultrasonic Flow meter.
5. List out few Obstruction less Flow meters.
6. State the working principle of Vortex Flow meter.
7. Draw the shapes of various shedder used in Vortex Flow meters
8. What is Mass flow rate?
9. What are the different types of Thermal Mass Flow meters?
10. State the working principle of Turbine Flow meter.
11. Mention the relationship between flow rate and force in Target Flow meter.
12. State the working principle of Hot wire anemometer.
13. Name the thermo elements used in Hot wire anemometer.
14. List out few Bidirectional Flow meters.

Part B

1. Draw the diagram which shows the operation of Electromagnetic Flow meter.
2. Brief the operation of Doppler Ultrasonic Flow meter with a neat sketch.
3. Mention the advantages and limitations of Ultrasonic Flow meter..
4. Write short notes on Swirl Flow meter with a neat sketch.
5. List out the advantages and limitations of Vortex Flow meter.
6. Discuss about Cross correlation flow meter.
7. Sketch Turbine Flow meter in detail.

Part C

1. Explain with a neat sketch the Principle of operation, Constructional details and Working of Electromagnetic Flow meter.
2. Explain with a neat sketch the Principle of operation, Constructional details and Working of Ultrasonic Flow meter.
3. Explain with a neat sketch the working principle of Vortex Shedding Meter for the measurement of flow.
4. Sketch and explain Thermal Mass flow meter and list out its advantages and limitations.
5. Explain Conveyor belt method of Solid flow measurement.
6. Sketch and explain Turbine Flow meter in detail.
7. In detail explain Target Flow meter with a neat sketch..
8. Explain Hot wire anemometer with a neat sketch.

UNIT V MEASUREMENT OF LEVEL, HUMIDITY AND MOISTURE

MEASUREMENT OF LEVEL

1. REASONS FOR THE MEASUREMENT OF LEVEL

1. **Inventory:** - One important reason for measuring level is to monitor Inventory in terms of volume (or) weight.
2. **Safety:** - Safety is another important aspect for measuring level. eg:- Filling on open vessel above its capacity could cause overflow. Overfilling an enclosed vessel could cause an overpressure condition that could result in major accident due to rupture of the vessel.
3. **Maximum use of storage space**
4. **Elimination of process upsets and load changes:** - Many processes require constant supply of inputs, which is difficult to maintain if the supply is delivered at varying rate. To eliminate such problems, a storage tank is often used between the supply and the process. Maintaining the level of storage vessel within a specified range is an important part of this strategy.
5. **Custody transfer:** - The amount of material that is bought and sold (called custody transfer) is based on Level measurement. (i.e) in terms of volume (or) weight. Especially in large vessels, an error of even an inch of measured level can result in very large errors in terms of volume. Therefore precise level measurement is required for Custody Transfer applications.

2. CLASSIFICATION OF MEASUREMENT METHODS

2.1) DIRECT AND INDIRECT MEASUREMENT:-

Direct Method: - It means that level is measured directly. eg.: - Float (or) Dipstick.

Indirect Method: - It means that some variable other than level is measured and used to infer the level measurement. eg:- Contents of the vessel may be weighed, and used to infer the level of the material within the vessel.

2.2) CONTINUOUS AND POINT MEASUREMENT:-

Continuous Measurement: - A Continuous level measurement system monitor's level within a range of all possible levels at all times. Continuous measurement is used for precise control to maintain the level of a material at a particular set point.

Single Point Measurement: - Single Point measurement is used to signal a low (or) high level limit (i.e.) when a vessel needs to be refilled (or) whether it is about to overflow.

2.3) INDICATION AND CONTROL: -

Indication: - Level measurements indicators include devices like Sight glasses and Gauges that give an on-site check of level. Readings can be used for monitoring or as a signal that some manual operations to be performed.

Control: - To produce a control signal, that is useful in automatic control systems, a level measuring device (or) sensor is combined with a transmitter that generates a pneumatic (or) electronic control signal, which will be proportional to the Level measurement. This signal is sent to a controller. The controller operates other devices such as valves (or) pumps, which in turn control the level.

2.4) INVASIVE AND NON INVASIVE: -

Invasive Method: - In this method, some part of the Level Sensor is in contact with the measured fluid or material. This is also known as **Contact (or) Insertion Method**. E.g.: - Float and Dipstick.

Non-invasive Method:- In this method no part of measurement system comes in physical contact with the contents of the vessel. This is also known as **Non-Contact Method**. Non-Invasive method is preferred when the measured fluid is hazardous (or) at very high pressure and temperature. E.g.: - Determining level by Weight method.

3. MEASUREMENT OF DIFFERENTIAL PRESSURE TO INDICATE LEVEL

The hydrostatic pressure method works well with open vessels, because the surface of the measured liquid is open to atmospheric pressure. If the tank is pressurized, the pressure gauge or transmitter will measure not only hydrostatic pressure that results from the height of the liquid column, but also the pressure above the stored liquid.

$$\text{Measurement} = \text{Hydrostatic Pressure} + \text{Vessel Pressure}$$

To solve the above problem, a Differential Pressure (DP) transducer is used. The high pressure side of the DP transducer is connected to tap near the bottom of the vessel to measure Hydrostatic Head plus Vessel Pressure. The low-pressure side of the DP transducer is connected to a tap near the top of the vessel to measure the pressure in the vapor space (i.e) Vessel Pressure.

The Resulting Differential Pressure = **High – Low**

$$= (\text{Hydrostatic Head} + \text{Vessel Pressure}) - \text{Vessel Pressure}$$

$$= \text{Hydrostatic Head.}$$

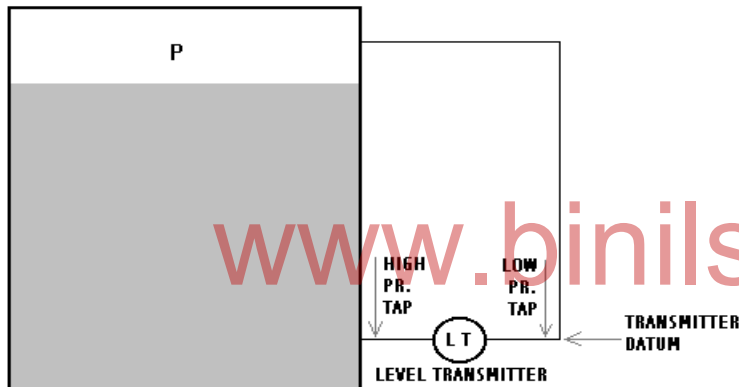

In this, compensation is provided for the pressure in the vapor space, and the output of the DP transmitter is proportional to liquid level only. When a DP transducer is used, pressure (P) affects the high and low pressure sides of the transducer equally and the effects of (P) are cancelled out.

If the measuring liquid is too hot or corrosive then different methods can be used to isolate the

Fig 5.1 Differential Pressure Level Measurement

instruments from the measured liquid. These include the use of isolating diaphragms, fluid filled isolation devices.

ADVANTAGES OF DIFFERENTIAL PRESSURE METHOD:-

1. It is common, well understood and economical.
2. No electrical components, hence no chances for sparks.

LIMITATIONS OF DIFFERENTIAL PRESSURE METHOD:-

1. Measurements are affected by any change in product density.
2. Special precautions required for the sensors if the measuring fluid is too hot, thick (or) corrosive fluid.

DIFFERENTIAL PRESSURE – BUBBLER METHOD:-

Another measurement system related to Hydrostatic Pressure measurement is commonly referred to as **Bubbler**. It consists of a bubbler tube placed inside the vessel. The Supply Pressure, Pressure Regulator, Bubbler, DP Transducer, Rotameter are connected through the pipeline.

When the supply pressure to the tube is greater than the fluid pressure, there will be flow through the tube, which produces bubbles in the liquid. Hence this method is known as **bubbler method**. As liquid level rises, back pressure at the bottom of the bubbler pipe increases. Because of the increase in back pressure, there is less flow through the bubbler pipe and an increase in pressure at the DP Transducer. The increase in pressure is

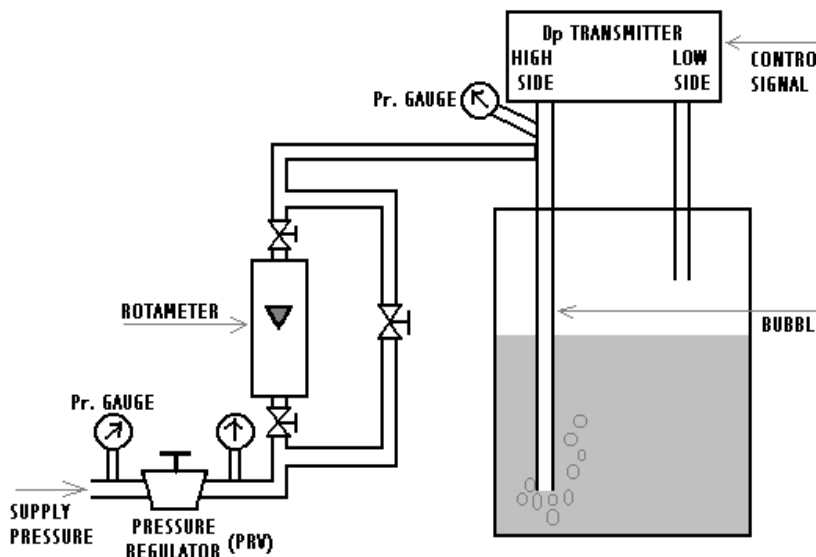

Fig 5.2 Level measurement using Bubbler method

proportional to increase in liquid level. As the level decreases, there is less backpressure and less resistance to flow through the bubbler pipe. Therefore more flow passes through the bubbler pipe and the pressure at the DP Transducer decreases.

Bubbler effectiveness depends on constant pressure supply, so a pressure regulator is used in this system.

ADVANTAGES OF BUBBLERS:-

1. Simplicity, Low cost.
2. Ability to locate the Gauge wherever needed.
3. Good solution for corrosive (or) other difficult fluids.
4. Calibration is easy.
5. Bubblers can be replaced easily.

LIMITATIONS OF BUBBLERS:-

1. Bubbler pipes are susceptible to plugging hence it requires frequent cleaning.
2. It is to be recalibrated whenever the product density changes.
3. Requires a constant source of pressure.
4. Using of air (or) other gas into the measured liquid may contaminate the liquid.

4. MEASURING THE MOVEMENT OF FLOAT

PRINCIPLE: - A float is an object that is lighter than the measured fluid, so that it rests on the surface of the measured fluid. Floats may be connected to indicating devices using different types of linkages. This is a direct, invasive method and can provide either point (or) continuous measurement.

DIFFERENT METHODS OF LEVEL MEASUREMENT USING FLOAT:-

- They are
1. Float Valve.
 2. Pneumatic Float Switches.
 3. Electrical Float Switches.
 4. Float Cable System.
 5. Annular Float (Magnetic Coupling)
 6. Magnetic Reed Switches.

4.1) FLOAT VALVE:-

This method is used as direct control. The float can be connected with a linkage directly to stem of the control valve. By changing the lever fulcrum from point A to point B, the action can be changed from float rising closes to float rising opens. To provide greater sensitivity, the float may operate a small pilot valve that controls the supply pressure used to operate a pneumatic actuator. Life example for such method is direct connected float valve in common house hold toilet tank.

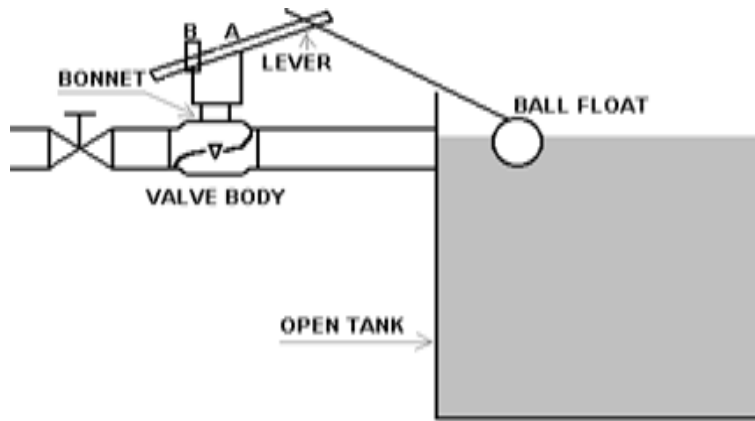

Fig 5.3 Float Valve

4.2) PNEUMATIC FLOAT SWITCHES:-

The Pneumatic Float Switch in which the rising and falling action of the float opens (or) closes the pneumatic circuit. The Pneumatic Float Switches are particularly used in control systems that use an air operated valve actuators and similar equipment.

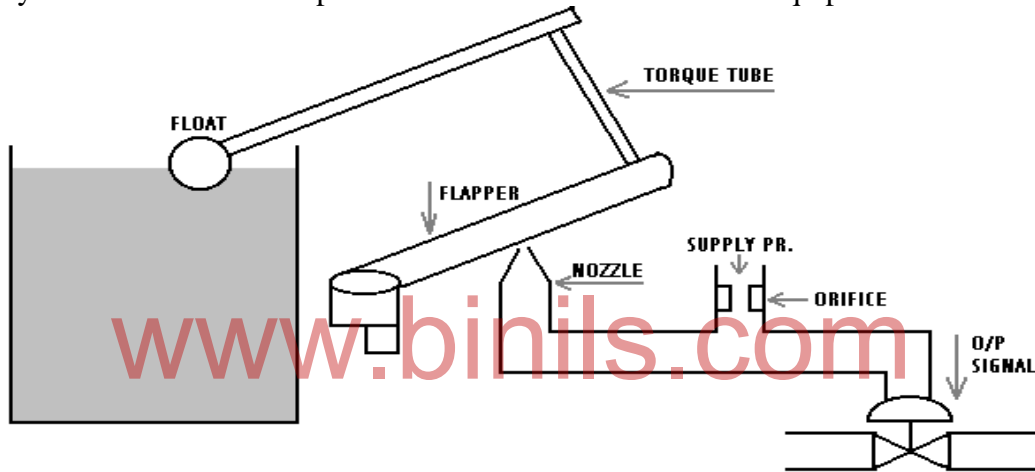

Fig 5.4 Pneumatic Float Switches

4.3) ELECTRICAL FLOAT SWITCH:-

One more common application of float is the operation of electrical switch that controls light (or) buzzer for high (or) low level indication. It can also be used in control circuit for the START and STOP of a pump (or) other equipment.

Fig 5.5 Float Cable System

4.4) FLOAT CABLE SYSTEM:-

Method 1: - The Fig shows the simplest form of float-operated mechanism for the continuous liquid level measurement. The movement of the float is transmitted to the pointer by a **Stainless Steel** (or) **Phosphorous Bronze** flexible cable wound around the pulley and the pointer indicates liquid level in the tank. The float is made up of corrosion resisting material such as **Stainless Steel**. And the float is rest on liquid level surface between the two grids to avoid error due to turbulence.

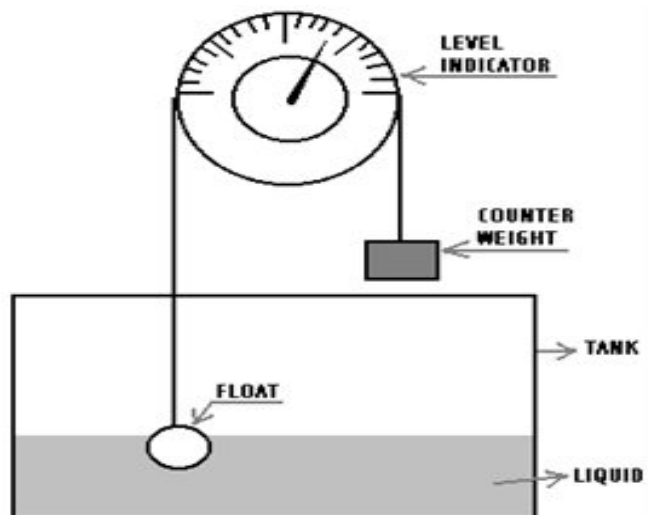

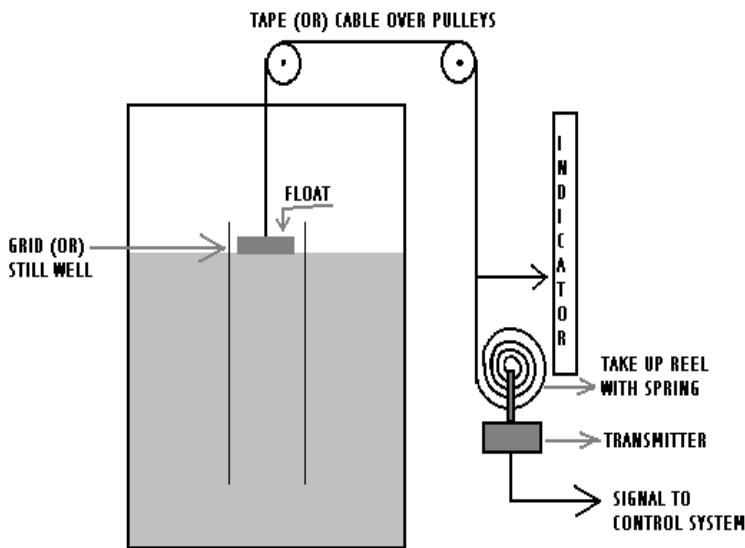

Fig 5.6 Float Cable System

ADVANTAGES OF FLOAT CABLE SYSTEM:-:-

1. Simple and inexpensive.
2. Easily understood.

LIMITATIONS OF FLOAT CABLE SYSTEM:-

1. Having many parts that can be obstructed, corroded (or) damaged by process fluids.
2. Parts are in direct contact with the measuring liquid, so these devices are not always suitable for difficult liquids.
3. It is not suitable for high-pressure vessels.
4. Floats tend to wander when there is turbulence in vessel (during filling) so they are used between the grids (or) still wells.

4.5) ANNULAR FLOAT (MAGNETIC COUPLING)

Another variation of the float approach uses an **annular magnetic float** that surrounds a closed center tube. Magnetic coupling between the annular float and the follower protects the components from hot, corrosive, viscous and other difficult fluids.

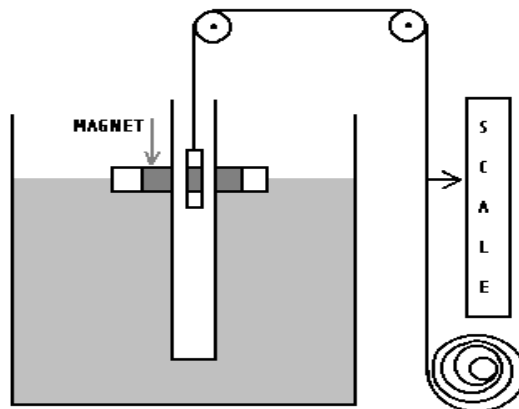

Fig 5.7 Level measurement using annular float

5. ELECTRICAL METHODS

5.1) LEVEL MEASUREMENT BY CHANGE IN CONDUCTANCE:-

PRINCIPLE:- Conductance is the electrical property that describes the ability of a material to pass an electric current. The chief requirement for a conductivity-based system is that the measured fluid must be **electrically conductive**. Many water-based liquids are good electrical conductors, while many petroleum-based materials are not.

Method 2: - One characteristic of the float and lever linkage is that the float must move over the same distance as the change in level that is measured. To eliminate the problem of long lever, floats are connected to cable (or) tape that is routed over pulleys (or) through a channel to a location outside the vessel as shown in Fig. The end of the cable is weighted (or) it is taken up on a spring reel. To provide indication, a pointer is attached to the cable and moves up and down over a calibrated scale.

ELECTRICAL CONDUCTION METHOD BY USING PAIR OF ELECTRODES:-

The basic arrangement for conductivity based level measurement system includes a pair of electrodes. The electrodes are mounted inside the vessel. Whenever the vapor space separates the two pair of electrodes, there is no conduction between the two. Whenever the measured liquid comes in contact with each pair of electrodes, an electrical circuit gets completed and it can be used for indication (or) control.

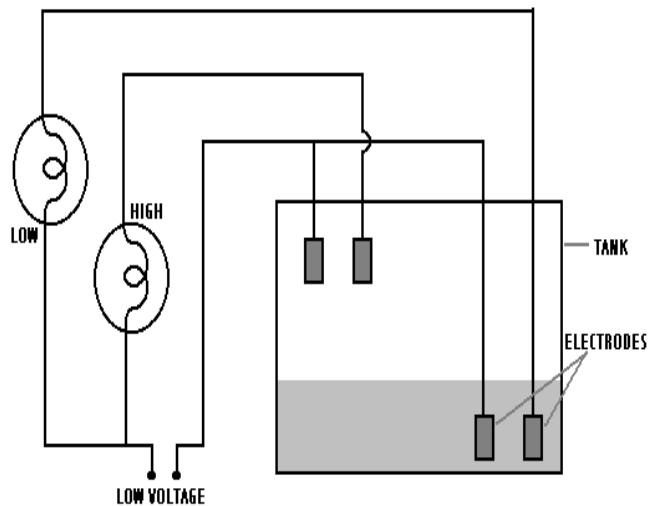

The circuit is powered by a low voltage. **Fig 5.8 Level measurement using pair of electrodes**

ELECTRICAL CONDUCTION METHOD BY USING VESSEL AS ONE OF THE ELECTRODE:-

In some applications, the vessel itself is used as one of the electrode and the circuit is made complete when the liquid contacts a single electrode suspended in the vessel. The vessel must be made up of conducting material. In this method, tank wall is used as one electrode. When the level is at (or) above the low limit, the circuit is completed and the lamp lights. When the lamp attached to the upper electrode lights, a high limit condition has been reached.

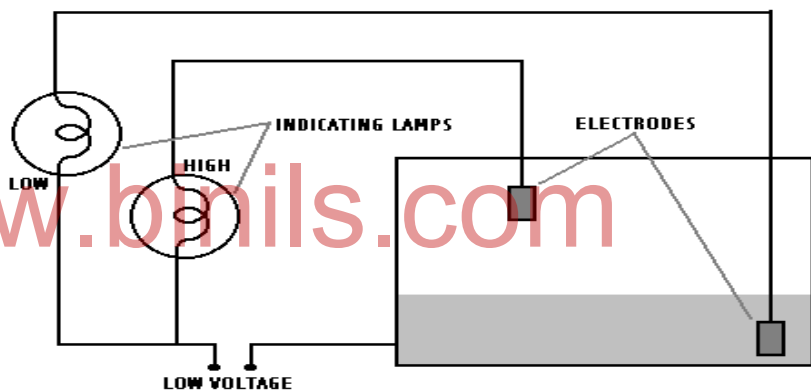
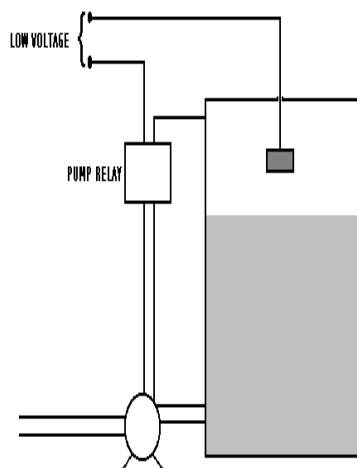

Fig 5.9 Level measurement using vessel as one of the electrode

APPLICATIONS OF ELECTRIC CONDUCTION METHODS:-

1. Conductivity methods are generally used for Point measurement and the Discrete (ON/OFF) control of equipment.
2. It is used for High and Low Level Indicators and Alarms, and also as the signal used to control the pump motors, valves etc.

Fig 5.10 On/Off Control of Pump



The Fig. shows the operation of motor control in pumps, to start the pump at low limit, and to stop the pump at high limit.

ADVANTAGES OF ELECTRIC CONDUCTION METHODS:-

1. Low cost.
2. Simple design.
3. Absence of moving parts.

LIMITATIONS OF ELECTRIC CONDUCTION METHODS:-

1. This method requires conductive liquid.
2. It is limited to Point measurement.
3. If the electrode becomes Corroded (or) Insulated with coatings (or) deposits, erroneous readings can result.

5.2) LEVEL MEASUREMENT BY CHANGE IN CAPACITANCE:-

PRINCIPLE: - Capacitance is the ability to store an electric charge. A capacitor consists of two conductive plates that are adjacent to each other and separated by dielectric. A dielectric is a non-conducting medium such as air or oil.

The amount of capacitance (C) is determined by three variables.

Area of the plate (A)

Distance between the two plates (d)

Dielectric constant (ξ)

$$C = \frac{\xi A}{D}$$

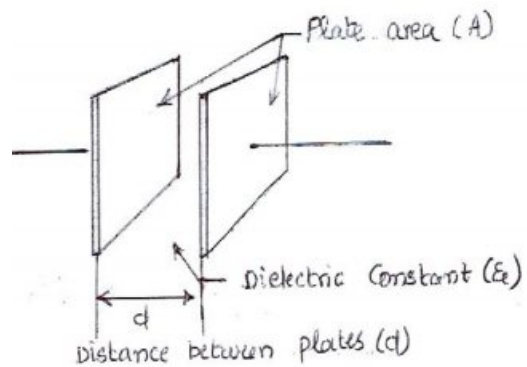

Fig 5.11 Capacitor

BASIC METHOD:-

By inserting a metal rod into an empty metal tank, a capacitor is formed. The rod is one capacitor plate and the tank itself is the second plate. The air in the space between the tank and the rod is dielectric.

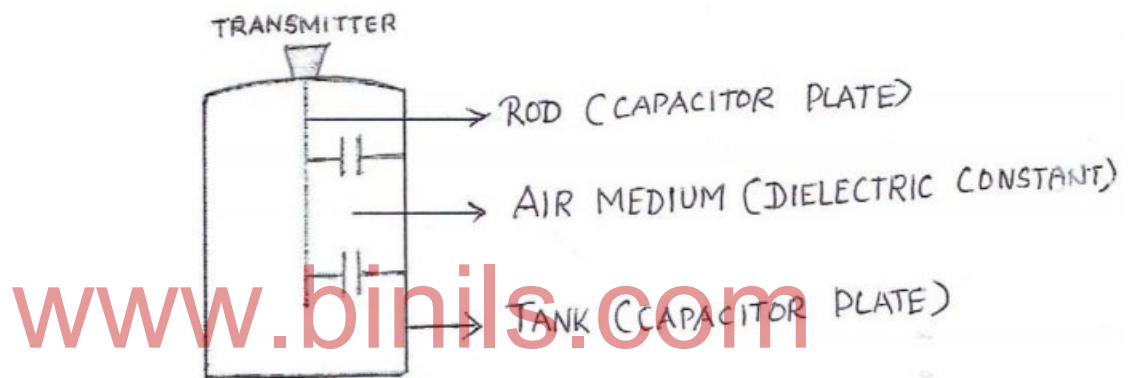

Fig 5.12 Basic method of Capacitance Level transducer

NON CONDUCTING FLUIDS:-

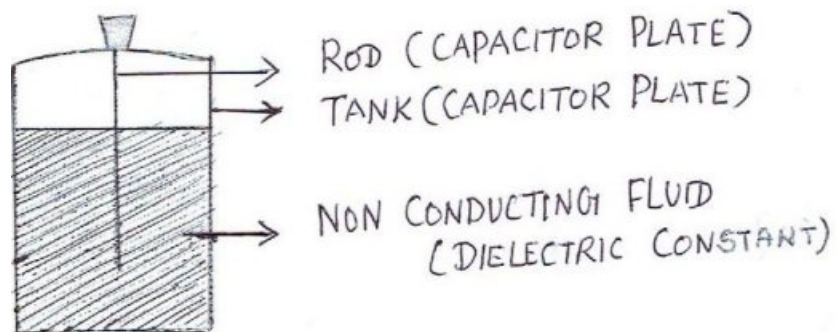

Fig 5.13 Capacitance Level transducer for non-conducting fluid

If the liquid is an insulator (non conductor) such as an oil (or) liquefied gas, the liquid acts as dielectric, so capacitance exists and it can be measured. As the tank is filled, the dielectric constant slowly changes from that of air to that of filling liquid. The change in capacitance can be measured and converted by appropriate electronics to a control signal. In this level is inferred from the change in capacitance produced by the change in dielectric constant,

CONDUCTING FLUIDS:-

If the stored liquid is a conductor such as water and many water based solutions, the plates are shorted out and the capacitance property does not exist. In such application, the rod is coated with an insulating material such as **Teflon (TFE)**. The rod and the stored fluid acts as the capacitor plate. The Teflon coating is the dielectric. As the level increases, the

area of the second plate increases, thus changing the capacitance between fluid and the rod. The change in capacitance is measured and converted to a control signal. The change in capacitance associated with the change in level is produced by the change in the plate area.

ADVANTAGES OF CAPACITANCE TRANSDUCER:-

1. Low Cost
2. No moving parts
3. Can be designed to tolerate high pressure and temperature.
4. Use of Cable type probes allows for the measurement of very long spans.

LIMITATIONS OF CAPACITANCE TRANSDUCER:-

1. Floating solids can cause erroneous readings if they have different dielectric constant than the measuring liquid.

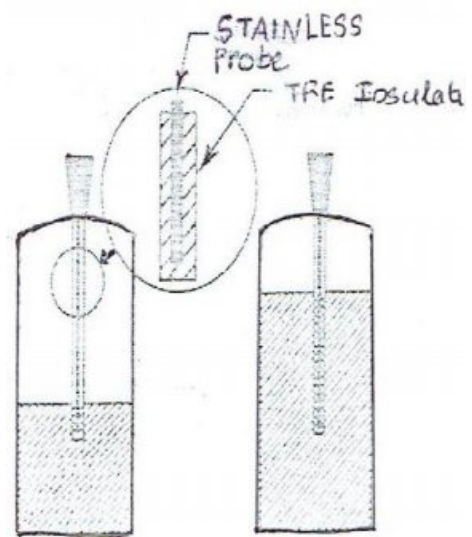
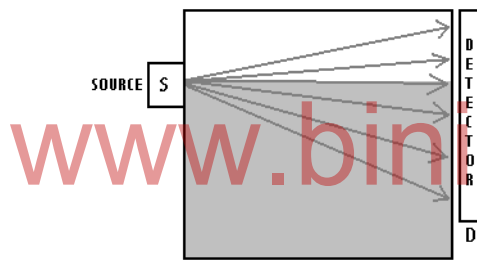
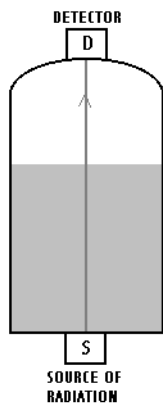

Fig 5.14 Capacitance Level transducer for non-conducting fluid

6. RADIATION METHOD

PRINCIPLE:- Radiation methods detect the level based on the amount of radiation absorbed when the amount of radiation passes through the measured material. This method can be used for either Point (or) Continuous measurement.



The various methods of Radiation and Absorption methods are
 (a) Gamma Radiation Method
 (b) Microwave Method.

GAMMA RADIATION METHOD:- (Level in Closed vessel)
 Gamma Radiation method comprises of a radiation Source and a Detector. Some of the

Fig 5.15 Radiation Method for Continuous measurement radiation sources used is **Cobalt 60, Caesium-137 and Radium-226**. A Detector is located on the side of the vessel opposite to the radiation Source. As the radiation passes through the vessel, the material being measured absorbs some of the radiation. The amount of radiation that is absorbed depends on quantity of mass in the vessel. If level increases, the larger mass absorbs more radiation, and the detectors detect less radiation. If level decreases, the less mass absorbs less radiation and the detectors detect more radiation.

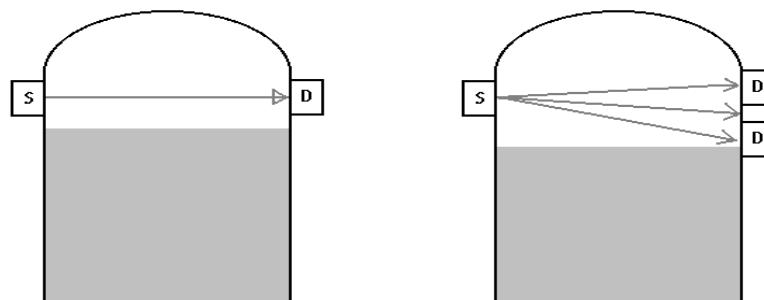

Fig 5.16 Radiation Method for Point measurement

Therefore, the magnitude of the signal received at the detector is inversely proportional to vessel level. (i.e.) A high vessel level results in small detector output. A Continuous measurement system has one or more long vertical detectors that cover the entire

measurement span. A single point system has a much smaller detector at the level (or) levels to be measured.

NEUTRON BACKSCATTER DETECTOR:- Neutron Backscatter detector is a portable device. This handheld device can be carried from one vessel to another and moved up and down over the measured range to determine the level. It emits a type of radiation that causes slow moving neutrons to be reflected back to its detector, when there is material inside the vessel. When it is moved to a point where there is no material inside the vessel, the device not sense any back scattering neutrons. Thus the level can be located.

ADVANTAGES OF RADIATION AND ABSORPTION METHODS:-

1. This method is totally Non-invasive.
2. When the material is extremely hot (or) corrosive this method can be used.
3. It is beneficial when the vessel cannot be opened for any reason.

LIMITATIONS OF RADIATION AND ABSORPTION METHODS:-

1. Most expensive.
2. Requires attention to safety issues.

7. SIGHT GLASS METHOD

A Sight Glass is another method of liquid level measurement. It is used for the Continuous Indication of liquid level within a tank (or) vessel. Sight Glass is portholes in the sides of the vessel at two places that can be used to determine the level of the vessel.

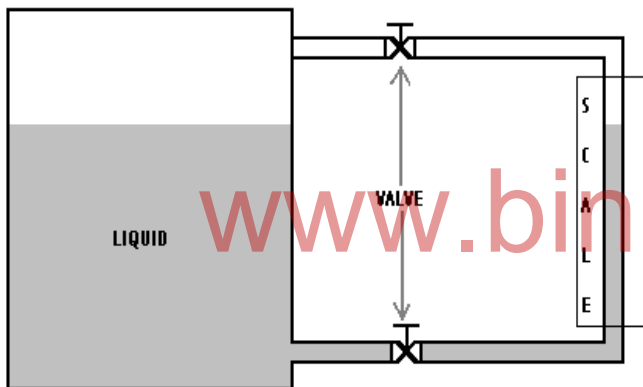

It consists of a clear vertical tube on the outside of the vessel with openings into the vessel at two different elevations. The tube is connected to the vessel so that fluid fills the tube to the same level as the vessel. This method provides a direct, continuous measurement.

Fig 5.17 Sight glass method for Level measurement

MAJOR DISADVANTAGE:- One major disadvantage of this method is the breakage of glass and leakage can occur. The probability of this occurring increases with high-pressure fluids. In this case, the glass tube is enclosed in a protective housing and two valves are provided as shown in the Fig. for isolating the gauge from the tank in the case of leakage in Sight Glass.

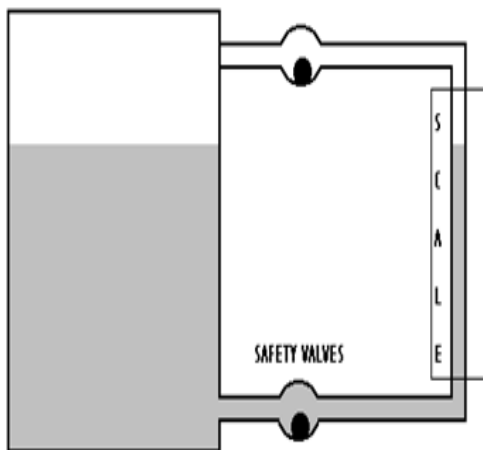

Fig 5.18 Sight glass with Check Valve

PROTECTION FROM BURSTING:-

a) SIGHT GLASS WITH CHECK VALVE:-

One device that provides protection against breakage is it includes safety valve at the points where the gauge is attached to the vessel. The safety valve consists of ball and seat type arrangement. It remains open during the normal operations. If the glass breaks, there will be a large pressure drop across the ball because of the rush of escaping fluid. This pressure drop forces the ball into a seat, thus sealing the vessel and prevents large leakages.

b) GLASS LESS DESIGN USING MAGNETIC FLOAT:-

This method protects against rupture by using a metal well instead of glass tube. The magnetic float inside the pressurized pipe rises and falls with the liquid level. The float is magnetically coupled to the indicator located inside a clear tube, which is outside the pressurized float tube.

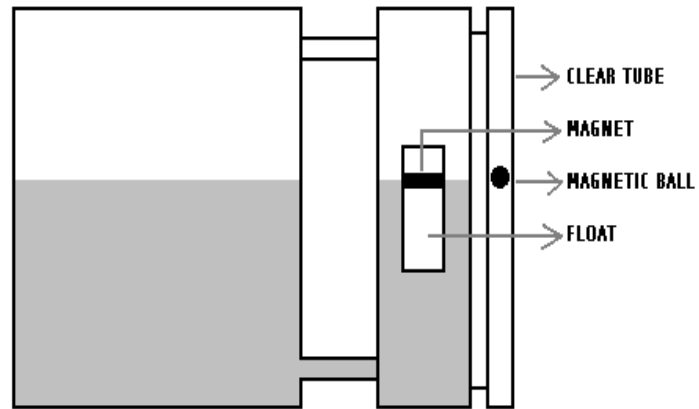

Fig 5.19 Magnetic float measurement using Sight glass method

ADVANTAGES OF SIGHT GLASS METHOD:-

1. Direct and Visual method.

LIMITATIONS OF SIGHT GLASS METHOD:-

1. Provision is made to prevent leakages, which occurs due to broken glass.
2. Indicators that provide visual reading through glass are not useful sometimes because of foamy (or) viscous liquids.
3. It cannot be used to provide a continuous control signal.

8. SOLID LEVEL MEASUREMENT

The level measurement is not only used in fluid handling industries. Nowadays the level measurement techniques are used in measuring the large quantities of solid materials in bulk quantity. The importance of solid level measurement is growing nowadays.

The solid level measurement can be done either by Point measurement (or) by Continuous measurement. The various types of solid level detectors are: -

1. Bin and Diaphragm type.
2. Rotating Paddle.
3. Grid Response Unit.
4. Gamma Ray Absorption method.
5. Weighing method.
6. Sonic method (Vibrating Fork).

8.1) BIN AND DIAPHRAGM TYPE:-

One of the oldest technique of Solid Level measurement is the Diaphragm type system which is suitable for Point control. So, when using this device, two units will be required to detect both the high and low levels. The device consists of a flexible diaphragm which is exposed to the solid material in the bin.

As the solid level rises, pressure forces the diaphragm and opens (or) closes the switch and with appropriate electrical circuitry an indication, alarm, (or) control may be introduced. This device could be operated under high pressure conditions but not under high temperature.

Fig 5.20 Bin and Diaphragm type

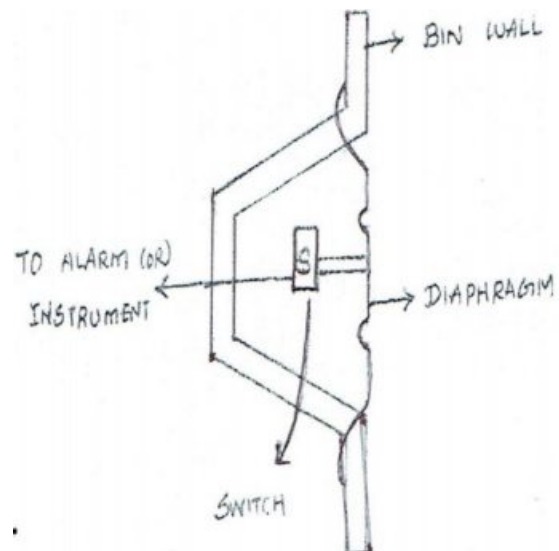

8.2) ROTATING PADDLE:-

In this method, a paddle is attached to the shaft driven by a synchronous motor. When the rotation gets resisted by the solid material, the rotation can be stopped. This can actuate an electrical switch. This method is suitable for top-level detection.

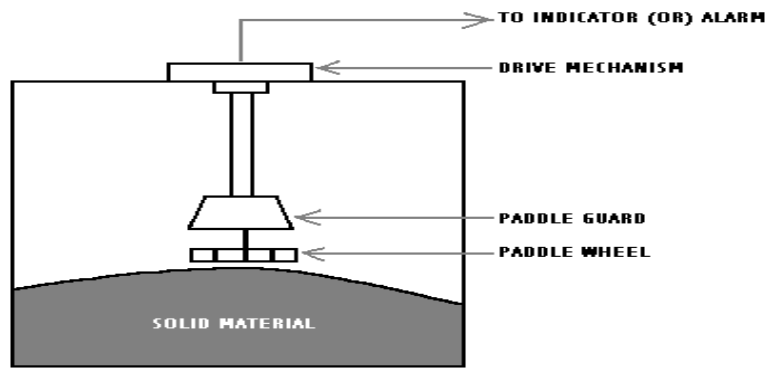

Fig 5.21 Rotating Paddle

8.3) GRID RESPONSE UNIT:-

It consists of thin metal rings connected together by rods to form a vertical cylindrical shaped grid. Normally the Grid is partially immersed in the moving solid bed. The Grid is connected to Torque Tube Mechanism. The more, the grid is immersed in the solid bed, i.e. the more is the level of the solid; the torque will be more on the torque tube.

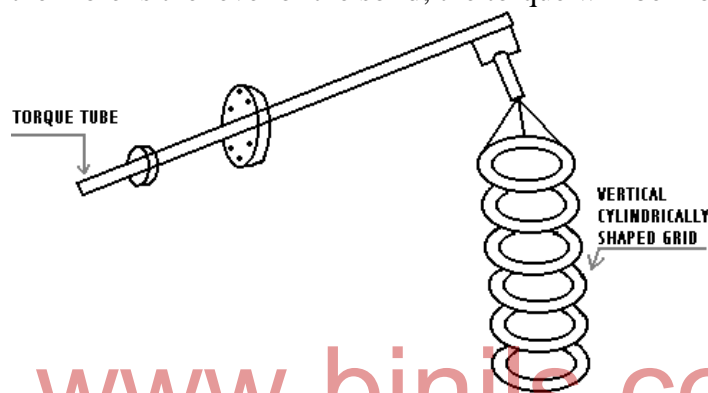

Fig 5.22 Grid response unit

The output is calibrated in terms of solid level. This is used for Continuous control of solid level in process vessels.

Application:- used at high pressure and high temperature (300°C).

8.4) GAMMA RAY ABSORPTION METHOD:-

Refer GAMMA RADIATION METHOD

8.5) SONIC METHOD (VIBRATING FORK):-

Sonic (or) Vibration method of level measurement is similar to Ultrasonic method. It uses considerably lower frequency to vibrate the tines of tuning fork. If the solid material covers the tines of tuning fork, a change in amplitude can be detected. This can be used for Point measurements only. It is an Invasive method. If the dry material is packed between the tines of fork, errors can be introduced.

Fig 5.23 Level measurement using Vibrating Fork

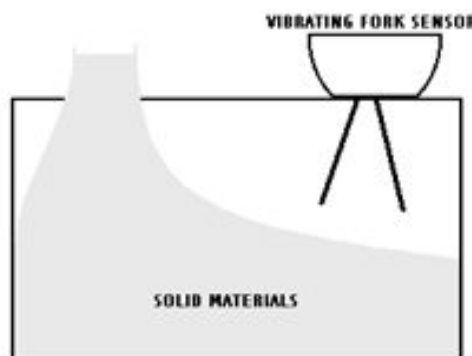

MEASUREMENT OF MOISTURE

Moisture: - Moisture is defined as the amount of water absorbed by a solid (or) liquid.

1. MEASUREMENT OF MOISTURE IN GRANULAR MATERIALS:-

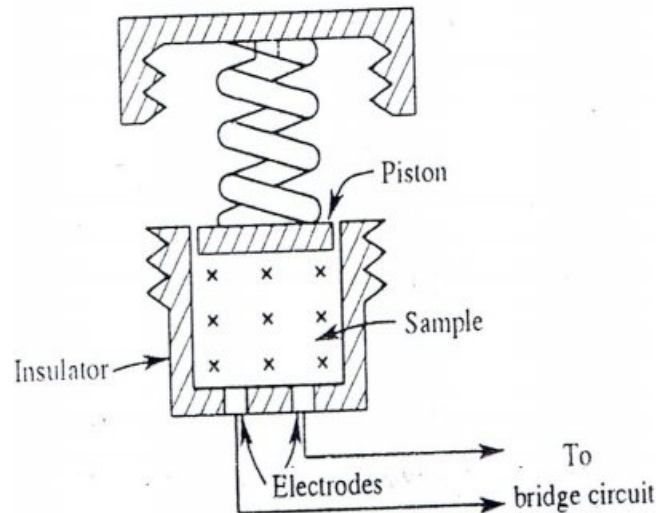

Fig 5.24 Measurement of moisture in granular materials

In this, contact between the sample and the electrode pair sometimes is not complete because of the sample structure. An optimum pressure is necessary to establish a good contact. Electrode structures are different for different materials. For granular materials, the construction is shown in the fig. It consists of a cup shaped electrode assembly. Material in measured volume is passed into the cup consisting of electrodes. A spring loaded piston closes the cup and maintain optimum pressure in the material. Based on the moisture in the material, the resistance gets decreases. The Bridge circuit is used here to get the direct reading.

2. MEASUREMENT OF MOISTURE IN SOLID PENETRABLE MATERIAL:-

For wood and wood products, the electrode consists of two to six sharp spear headed conductors embedded in a suitable insulation handle as in the shown fig. The spacing of the spearheads in an electrode is more than $\frac{3}{4}$ " and the penetrating length is larger than $\frac{5}{16}$ ". The spearheads are introduced into the sample and the conductivity measured. Hence based on the moisture in the wood, the resistance can be decreases (or) increases. And these can be connected directly to the Wheatstone bridge circuit for direct reading..

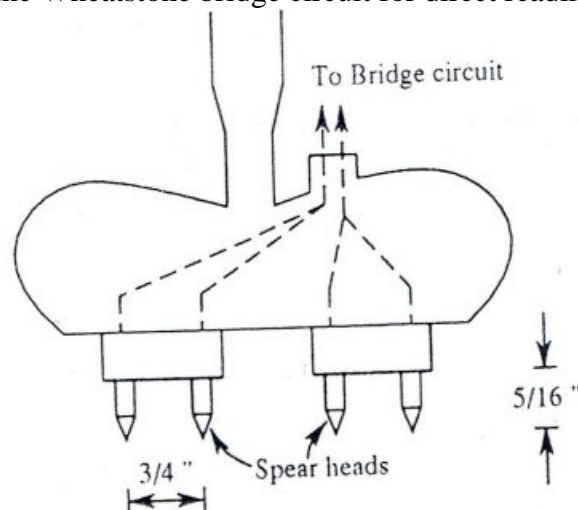

Fig 5.25 Measurement of moisture in solid penetrable materials like wood

3. MEASUREMENT OF MOISTURE IN PAPERS AND TEXTILES:-

For continuous measurement in textile webs (or) paper sheets, the electrode consists of live and dead roller. The dead roller is grounded. If the moisture content of the web material changes, then the resistance also changes. And connecting these systems directly to Wheatstone bridge, the measurement can be done directly.

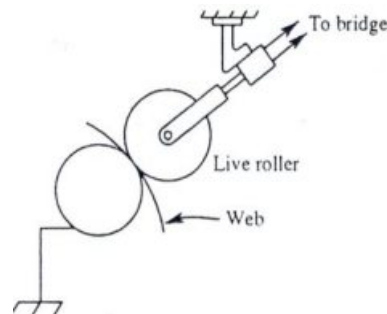

Fig 5.26 Measurement of moisture in papers and textiles

MEASUREMENT OF DENSITY AND SPECIFIC GRAVITY

1. DEFINITIONS:-

1. **Density:-** $\text{Density of a material} = \text{Weight} / \text{Volume}$

At given condition of temperature and pressure.

2. **Specific gravity of Liquid :-**

$\text{Density of the liquid at flowing temperature} / \text{Density of water at } 60^\circ\text{F (15.5}^\circ\text{C)}$

3. **Specific gravity of Gas:-**

$\text{Density of flowing gas} / \text{Density of air at standard conditions.}$

Note: The specific gravity of water is 1 at 15.5°C.

2. MEASUREMENT OF DENSITY USING WEIGHING TUBE TYPE:-

The liquid whose density to be measured is made to flow through a U-tube which is kept horizontally on flexure pivot and the pivot is located at the open ends of the tube. Any force-measuring transducer measures the weight of the tube and its liquid content either by Pneumatic (or) Electrical method. One way of measuring is a spring and Pneumatic displacement transducers, continuously weigh a definite volume of flowing liquid contained within the U-tube. Flexible coupling isolate external forces from the U-tube.

A pneumatic force balance feedback system also can be used to measure the weight. This minimizes deflection and thus reduces errors due to variable spring effects of flexible couplings and flexure pivots.

Fig 5.27 Weighing tube type for density measurement

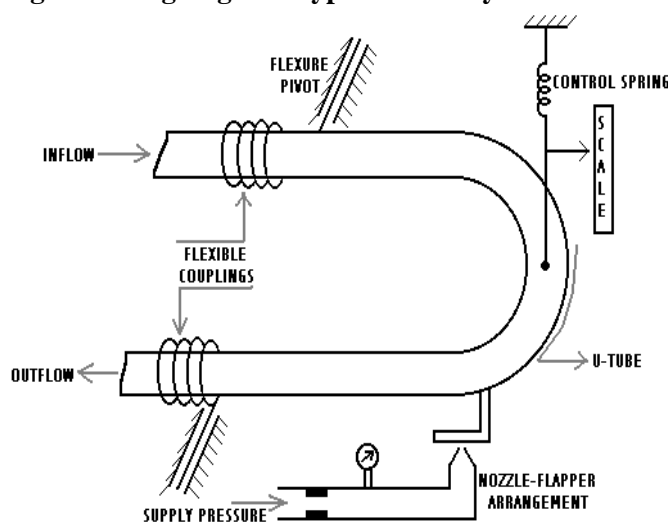

MEASUREMENT OF HUMIDITY

1. DEFINITIONS:-

1. **Humidity:** Humidity is the measure of water vapour present in a gas. It is usually measured as Absolute Humidity (or) Relative Humidity..

2. **Absolute Humidity:** It is the mass of water vapour present per unit volume.

3. **Relative Humidity:** It is the ratio of Moisture content of the gas

Maximum moisture the gas can contain at that temp.

2. PSYCHROMETER:-

PRINCIPLE:- A Psychrometer is a device for measuring the moisture content of air (or) other gases by the readings of two thermometers. One with its bulb directly exposed to the atmosphere known as **Dry bulb thermometer** and the other with its bulb covered by a wick maintained continuously wet known as **Wet bulb thermometer**. The Wet and Dry bulb temperature can be related to Relative humidity by means of a **Psychrometric chart**.

WET AND DRY BULB PSYCHROMETER:-

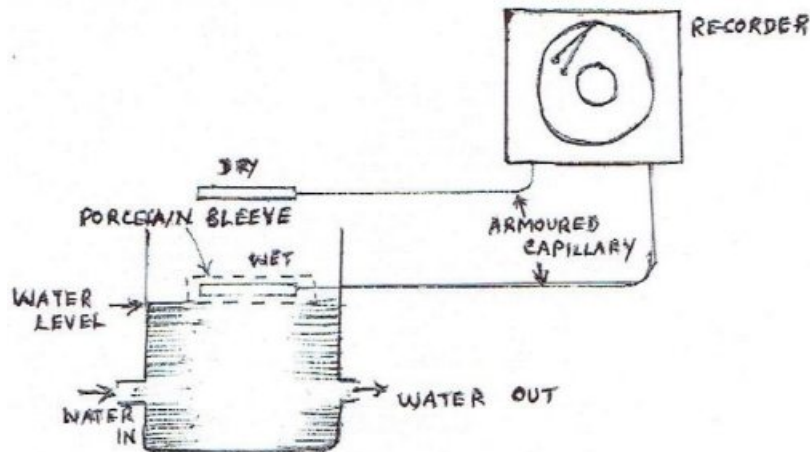

Fig 5.28 Wet and Dry Bulb Psychrometer

Wet and Dry bulb Psychrometers for industrial use are available in a wide variety of types. A typical installation consists of a two pen recording thermometer using filled systems. One of the two bulbs is covered with a woven cloth wick which dips into a reservoir of water. motor driven blower may be provided to give the necessary flow of air across the wet bulb (or) it can be omitted if the installation is such a way that air velocity is adequate. An alternate construction uses porous ceramic sleeve instead of a cloth wick.. Water level may be maintained by a constant level bottle feed.

Similar instruments which use RTDs (or) Thermocouples (usually reading temp difference between Wet bulb and Dry bulb) instead of recording the two variables separately and may use a modified Wheatstone Bridge circuit to read Relative Humidity.

ADVANTAGE OF PSYCHROMETER:-

1. Better accuracy than Hygrometer.

LIMITATION OF PSYCHROMETER:-

1. Reading requires interpretation by charts (or) tables to convert into the units desired.

Application:- Used in the field of drying and it is also extensively used in air conditioning.

3. HAIR HYGROMETER:-

PRINCIPLE:- The term Hygrometer is applied to Humidity measuring devices, actuated by the change in dimensions of a Hygroscopic material. (ie) Change in Relative Humidity due to the surrounding atmosphere. Hair and most other organic materials absorb moisture from the ambient atmosphere. Some of the other materials used are Animal membrane, synthetic fibre, films etc.

Fig 5.29 Hair Hygrometer

CONSTRUCTION & WORKING:-

As the water content of the hair increases, the hair lengthens closely approximating Relative humidity. Human hair, therefore in a suitable structure can operate an indicating pointer (or) a recorder pen (or) a controller. The requirements of a good hygrometer are simple but cannot be

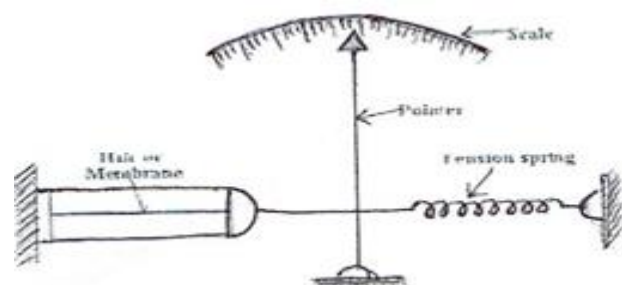

easily executed. For giving strength, a number of hairs are paralleled and they must be sufficiently separated to give free access to the moisture and also under uniform tension, so that each hair functions properly. The hair itself can respond to Relative humidity up to 100%. Although, Hair hygrometer commonly carry a scale reading from 0 to 100% RH, their actual field of use is limited to approximately 15 to 90% RH. The Hair hygrometer is calibrated against a Sling Psychrometer. Wood also expands and contracts with the change in humidity.

QUESTIONS

Part A

1. State the working principle involved in Float Level measurement.
2. List out the different methods of level measurement using float.
3. Name the materials used in the construction of Float for level measurement.
4. What is Conductance?
5. What is the chief requirement in Conductivity based Level measurement?
6. State the principle used in Capacitance level transducer.
7. Name the Radiation methods used in Level measurement.
8. Mention the radiation sources used for Level measurement.
9. List out the different methods of Solid level measurement.
10. Define Moisture.
11. Define Density and Specific gravity..
12. What is Humidity?
13. What are the types of Humidity?
14. State the working principle of Psychrometer.
15. Mention the Hygroscopic materials used in Hair Hygrometer.

Part B

1. Describe how the level can be measured using differential pressure method.
2. With the diagram show how the level can be measured by the change in conductance.
3. Write short notes on level measurement using Sight glass method.
4. Discuss about the measurement of moisture in granular materials.
5. Briefly discuss the measurement of moisture in papers and textiles.
6. Define Absolute Humidity and Relative Humidity.
7. Write short notes on Hair hygrometer.
8. Brief the operation of density measurement using Weighing tube type.

Part C

1. With a neat sketch, explain Float type Level measurement.
 2. Sketch and explain Electrical conduction method of level measurement.
 3. Explain Level measurement using change in Capacitance.
 4. Explain Radiation type Level measurement with a neat sketch.
 5. With a neat sketch explain Solid Level measurement.
 6. Explain the measurement of moisture in granular materials and in solid penetrable material with a neat sketch.
 7. Sketch and explain the Principle and Operation of Psychrometer.
 8. In detail explain Hair hygrometer with a neat sketch.
-