

**GOVERNMENT OF TAMILNADU
DIRECTORATE OF TECHNICAL EDUCATION
CHENNAI – 600 025**

STATE PROJECT COORDINATION UNIT

Diploma in Electrical and Electronics Engineering

Course Code: 1030

M – Scheme

e-TEXTBOOK

on

GENERATION, TRANSMISSION AND SWITCHGEAR

for

V Semester DEEE

Convener for EEE Discipline:

Er.R.Anbukarasi ME.,
Principal,
Tamilnadu Polytechnic College,
Madurai, 625011.

Team Members for GENERATION ,TRANSMISSION AND SWITCHGEAR

THIRU. M.SHANMUGANANTHAN.
HOD/ELECTRICAL
TAMILNADU POLYTECHNIC COLLEGE, MADURAI

THIRU M.SARAVANAKUMAR, B.E.,
PTLECT/ELECTRICAL
TAMILNADU POLYTECHNIC COLLEGE, MADURAI

SELVI .S.LIJIBACKIYA, B.E.,
PTLECT/ELECTRICAL
TAMILNADU POLYTECHNIC COLLEGE, MADURAI

Validated by:

Dr. V.SARAVANAN.,
Associate Professor,
Department of Electrical and Electronics Engineering,
Thiagarajar College of Engineering, Madurai.

DIPLOMA IN ELECTRICAL AND ELECTRONICS ENGINEERING
M - SCHEME

Course Name: Diploma in Electrical and Electronics Engineering

Subject Code: 33051

Semester: V

Subject Title: GENERATION, TRANSMISSION AND SWITCHGEAR

RATIONALE

Energy is the basic necessity for the economic development of a country. As a matter of fact, there is a close relationship between the energy used per person and his standard of living. The greater per capita consumption of energy in a country, the higher is the standard of living of its people. The modern society is so much dependent upon the use of electrical energy that it has become a part of our life. So it is necessary to get adequate knowledge in Electrical power generation and transmission leads to include this subject.

www.binils.com

OBJECTIVES

- To Understand
- Conventional power plants-Layout and choice of site
- Renewable energy sources and power generation
- Grid system and Economics of power generation
- A.C Transmission-Supports, conductors, Effects, Regulation and Efficiency
- H.V.D.C Transmission
- Line Insulators and underground cables
- Circuit breakers, Fuses and Lightning arresters

DETAILED SYLLABUS

1030 - GENERATION , TRANSMISSION AND SWITCHGEAR (M - SCHEME)

UNIT 1 - GENERATION OF ELECTRICAL POWER

PG.NO(5-40)

Introduction- Conventional methods of power generations – schematic arrangement and choice of site for Hydel, Thermal, Nuclear power plants-Advantages and Disadvantages-comparison of these power plants - Principle and types of co generation.

Schematic arrangement of Diesel, Gas, Pumped storage schemes-Advantages and Disadvantages-Renewable Energy sources Basic principle of Solar Energy, Grid Connected Solar PV System, Standalone Solar PV System, Hybrid Solar PV System, Wind Power Generation.

Grid or Inter connected system-Advantages of Inter connected systems- Load Transfer through Inter connector-Load curves and Load duration curves-connected load-Average load-Maximum Demand Factor- Plant capacity factor-Load factor and its significance-Diversity factor-Tariff – Types- Factors influencing tariff, Simple problems - Load sharing between base load and peak load plants-Load Dispatching centre standalone system.

UNIT 2 - A.C. AND H.V.D.C TRANSMISSION

PG.NO(41-81)

A.C. Transmission:

Introduction-Typical Layout of A.C. Power supply scheme various system of power Transmission-Advantages and Disadvantages of A.C Transmission- High Transmission Voltage Advantages-Economic choice of Transmission voltage-Elements of a Transmission Line- Economic choice of conductor size-Kelvin's Law- Its limitation-over Head Line-Conductor materials and their properties-Line supports-its properties-Types of supports and their applications-spacing between conductors-length of span-Sag in over head lines-Calculation of Sag-When the supports are at equal and unequal levels- Problems- Effect of wind and ice loading over the line conductor (Qualitative treatment only) - constants of a Transmission line- Transposition of Transmission lines-Skin Effect- Ferranti Effect-Corona formation and corona loss-Factors affecting corona-Advantages and Disadvantages-Classification of O.H. Transmission lines- performance of single phase short Transmission line - voltage regulation and Transmission Efficiency-Problems.

H.V.D.C Transmission:

Advantages and Disadvantages of D.C Transmission Layout Scheme and principle of High Voltage D.C Transmission-D.C link configurations (monopolar, Bipolar and Homopolar)-HVDC convertor Station

UNIT 3 -- LINE INSULATORS AND UNDERGROUND CABLES

PG.NO(82-111)

Line Insulators:

Introduction - Line Insulator materials-Properties of Insulators Types & causes of failure of Insulators-Testing of Insulators-Potential Distribution over suspension Insulator string-String Efficiency - Methods of improving string efficiency- problems.

Underground cables:

Introduction-Advantages and requirement of cables-construction- of a three core cable-Insulating materials for cables properties of Insulating materials used in cables-classification of cables-cables for three phase service-construction of Belted cable, screened cable, Pressure cables-Laying of underground cables-Direct laying, Drawing system, Advantages and Disadvantages-Grading of cables- capacitance grading, Inter sheath grading (No derivation and Problems)-cable faults-O.C, S.C and Earth faults.

UNIT 4 - CIRCUIT BREAKERS AND OVER VOLTAGE PROTECTION PG.NO(112-166)

Switch gear-Essential features of Switch gear-faults in a Power system (definition only). Circuit Breakers Basic principle of circuit Breaker -Arc Phenomenon-methods of Arc extinction-Arc voltage - Restriking voltage and recovery voltage-Rate of rise of restriking voltage-current chopping-Interruption of capacitive current -resistance switching-C.B ratings – Breaking capacity, making capacity, short time rating - Auto reclosing in circuit Breakers - Classification of Circuit Breakers – Construction and Working principle of Oil Circuit Breaker, Air blast Circuit Breaker, E.L.C.B, Miniature circuit breaker (M.C.B) , Residual current circuit breaker , SF6 and vacuum Circuit Breaker D.C breaking -Problems of D.C breaking-Schematic for HVDC CB producing current zero.

Fuses-Desirable characteristics-Fuse Element materials-current rating of fuse elements-fusing current-Cut off current-L.V fuses-Rewirable fuse, HRC cartridge fuse, HRC fuse with tripping device - H.V. fuses & cartridge type, liquid type and metal clad-fuses-Comparison of fuse and circuit breaker.

Over voltage protection:

Voltage surge- causes of over voltage-Lightning-Types of lightning strokes -Direct stroke, indirect stroke-Harmful Effects of lightning - Protection against lightning-Earthing screen, overhead ground Wires, Lightning arresters- Expulsion type, Gapless arrester.

UNIT 5 -- PROTECTIVE RELAYS AND GROUNDING PG.NO(167-207)

Protective relays:

Basic principled-Fundamental requirements of protective relaying- Primary and back up Protection-relay characteristics-relay timing - Instantaneous relay -Inverse time relay and Definite time lag relay- Inverse definite minimum time relay classification of relays-Construction, Principle of operation and applications of Induction type over current relay (Directional and Non directional), Distance relay, Differential relay, Negative sequence relay, Induction type reverse power relay, Earth leakage relay. Static relays- Basic elements of static relay

Grounding:

Introduction-Equipment grounding- system grounding ungrounded grounding, Resistance grounding Reactance grounding, resonant Neutral system-Necessity of Neutral grounding -methods-solid grounding-Earthing Transformer.

UNIT I

GENERATION OF ELECTRICAL POWER

1.1 Introduction

Sources of electricity are available everywhere in the world. Worldwide, variety of energy resources available to generate electricity.

These energy resources fall into two main categories

- (i) Renewable (or) Non-conventional sources of energy
- (ii) Non-renewable energy resources (or) Conventional sources of energy.

These resources can be used as a source to generate electricity, which is a very useful way of transferring energy from one place to another.

1.1.1 Conventional sources of energy: Coal, petroleum, natural gas, fissionable materials like uranium.

1.1.2 Non-conventional sources of energy: Wind, Hydro Power, solar, Ocean Tidal Energy, Interior of the Earth, Biogas, Plants, Vegetable waste etc.

www.binils.com

1.2.1 Conventional Energy Sources:

The energy sources which cannot be compensated, once these are used is called conventional energy sources. Some important conventional energy sources are discussed below:

1. Coal:

Power plants burn fossil fuels to heat water and produce steam. The steam pushes around turbines in a generator which converts mechanical energy in to electrical energy.

2. Hydropower:

Energy obtainable from water flow or water falling from a higher potential to lower potential, is known is hydro- power. It is a conventional and renewable form of energy which can be transmitted to long distance through cables and wires.

3. Nuclear energy:

Nuclear fission of uranium produces heat, and this heat is used to heat the water and make steam. The steam rotates turbines which turn generators. The generators produce electricity.

1.2.2 Non conventional energy sources:

The conventional energy sources discussed above are exhaustible and in some cases, installation of plants to get energy is highly expensive. In order to meet the energy demand of increased population, alternate nonconventional natural Resources sources of energy is developed which should be renewable and provide a pollution free environment.

Some nonconventional, renewable and inexpensive energy sources are described below:

1. Solar energy.
2. Wind energy.
3. Tidal energy.
4. Geothermal energy.
5. Bio-mass based energy.

1.3 THERMAL POWER STATION

1.3.1 Working principle

In a thermal power plant a steam turbine is rotated with the help of high pressure and high temperature steam by using fossil fuels and this rotation is transferred to a generator to produce electricity.

1.3.2 Schematic arrangement of steam power station

Steam power station simply involves the conversion of heat energy into electrical energy. The schematic arrangement of a modern steam power station is shown in Figure.

The whole arrangement can be divided into the following stages:

- Coal and ash handling arrangement
- Steam generating plant
- Steam turbine
- Alternator
- Feed water
- Cooling arrangement

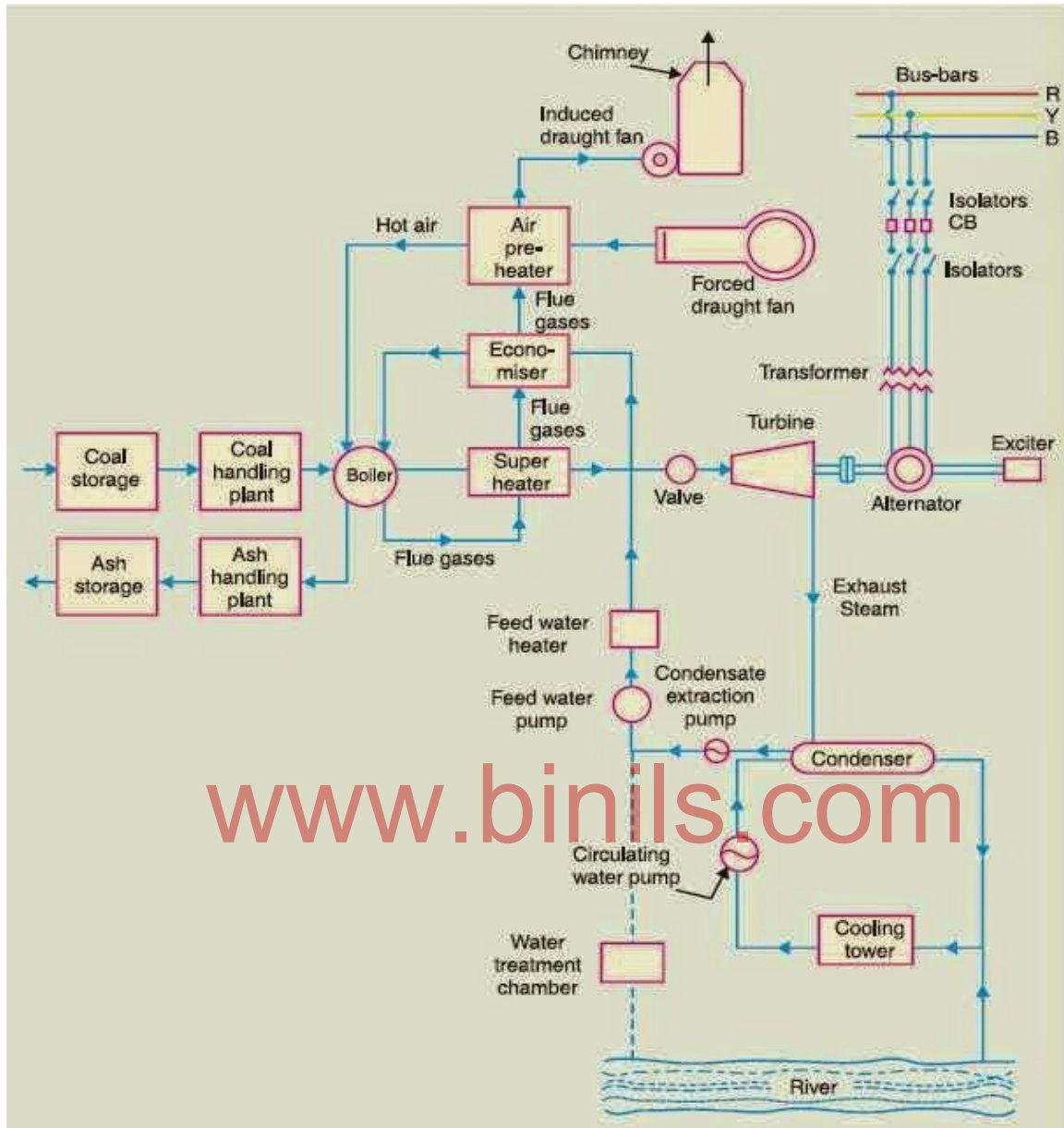

Fig 1.1

1.3.3 Coal and ash handling plant:

The coal is transported to the power station by road or rail and is stored in the coal storage plant. Storage of coal is primarily a matter of protection against coal strikes, failure of transportation system and general coal shortages. From the coal storage plant, coal is delivered to the coal handling plant where it is pulverized (i.e., crushed into small pieces) in order to increase its surface exposure, thus promoting rapid combustion without using large quantity of excess air. The pulverized coal is fed to the boiler by belt conveyors. The coal is burnt in the boiler and the ash produced after the complete combustion of coal is removed to the ash handling plant and then delivered to the ash storage plant for disposal. The removal of the ash from the boiler furnace is necessary for proper burning of coal.

1.3.4. Steam generating plant:

The steam generating plant consists of a boiler for the production of steam and other auxiliary equipment for the utilization of flue gases.

(I) Boiler:

The heat of combustion of coal in the boiler is utilized to convert water into steam at high temperature and pressure. The flue gases from the boiler make their journey through superheated, economizer, air pre-heater and are finally exhausted to atmosphere through the chimney.

(ii) Super heater:

The steam produced in the boiler is wet and is passed through a super heater where it is dried and superheated (i.e., steam temperature increased above that of boiling point of water) by the flue gases on their way to chimney. Superheating provides two principal benefits.

Firstly, the overall efficiency is increased. Secondly, too much condensation in the last stages of turbine (which would cause blade corrosion) is avoided. The superheated steam from the super heater is fed to steam turbine through the main valve.

(iii) Economizer:

An economizer is essentially a feed water heater and derives heat from the flue gases for this purpose. The feed water is fed to the economizer before supplying to the boiler. The economizer extracts a part of heat of flue gases to increase the feed water temperature.

(iv) Air pre-heater:

An air pre-heater increases the temperature of the air supplied for coal burning by deriving heat from flue gases. Air is drawn from the atmosphere by a forced draught fan and is passed through air preheater before supplying to the boiler furnace. The air preheated extracts heat from flue gases and increases the temperature of air used for coal combustion. The principal benefits of preheating the air are increased thermal efficiency and increased steam capacity per square meter of boiler surface.

1.3.5 Steam turbine:

The dry and superheated steam from the super heater is fed to the steam turbine through main valve. The heat energy of steam when passing over the blades of turbine is converted into mechanical energy. After giving heat energy to the turbine, the steam is exhausted to the condenser which condenses the exhausted steam by means of cold water circulation.

1.3.6 Alternator:

The steam turbine is coupled to an alternator. The alternator converts mechanical energy of turbine into electrical energy. The electrical output from the alternator is delivered to the bus bars through transformer, circuit breakers and isolators.

1.3.7 Feed water:

The condensate water from the condenser is used as feed water to the boiler. Some water may be lost in the cycle which is suitably made up from external source. The feed water on its way to the boiler is heated by water heaters and economizer. This helps in raising the overall efficiency of the plant.

1.3.8 Cooling arrangement:

In order to improve the efficiency of the plant, the steam exhausted from the turbine is condensed by means of a condenser. Water is drawn from a natural source of supply such as a river, canal or lake and is circulated through the condenser. The circulating water takes up the heat of the exhausted steam and itself becomes hot. This hot water coming out from the condenser is discharged at a suitable location down the river. In case the availability of water from the source of supply is not assured throughout the year, cooling towers are used. During the scarcity of water in the river, hot water from the condenser is passed on to the cooling towers where it is cooled. The cold water from the cooling tower is reused in the condenser.

www.binils.com

1.3.9 Advantages:

1. Fuel cost of thermal power plant is relatively low.
2. We can produce thermal energy almost every where in the world.
3. Heat production System is simple compared to other system.
4. Overall system cost effective.
5. Easy mechanism.
6. Same heat could be reused.
7. Easier Maintenance of power station.
8. Use of water is prominent here, therefore, any places with ample supply of water is a perfect location for installing a thermal power station.
9. Thermal power plant requires comparatively small space to be installed.

1.3.10 Disadvantages:

1. Huge emission of Carbon-di-oxide (CO₂) in the atmosphere.
2. Exhausted gases harms outside environment badly.
3. overall efficiency is low.
4. Thermal engines requires huge amount of lubricating oil that is very expensive.

5. Nuclear thermal power plant demands excessive amount of water for cooling purpose.
6. Coal type thermal power plant requires comparatively larger duration before it supply generated power to the grid.
7. This type of power station ultimately responsible for raise in sea water level.

1.4 HYDRO ELECTRIC POWER PLANT

1.4.1 Types of Hydro-Power Plants

- **Conventional Plants:**

Conventional plants use potential energy from dammed water. The energy extracted depends on the volume and head of the water. The difference between height of water level in the reservoir and the water outflow level is called as water head.

- **Pumped Storage Plant:**

In pumped storage plant, a second reservoir is constructed near the water outflow from the turbine. When the demand of electricity is low, the water from lower reservoir is pumped into the upper (main) reservoir. This is to ensure sufficient amount of water available in the main reservoir to meet the peak loads.

- **Run-Of-River Plant:**

In this type of facility, no dam is constructed and, hence, reservoir is absent. A portion of river is diverted through a penstock or canal to the turbine. Thus, only the water flowing from the river is available for the generation. And due to absence of reservoir, any oversupply of water is passed unused.

1.4.2 Layout and working of hydroelectric power plant

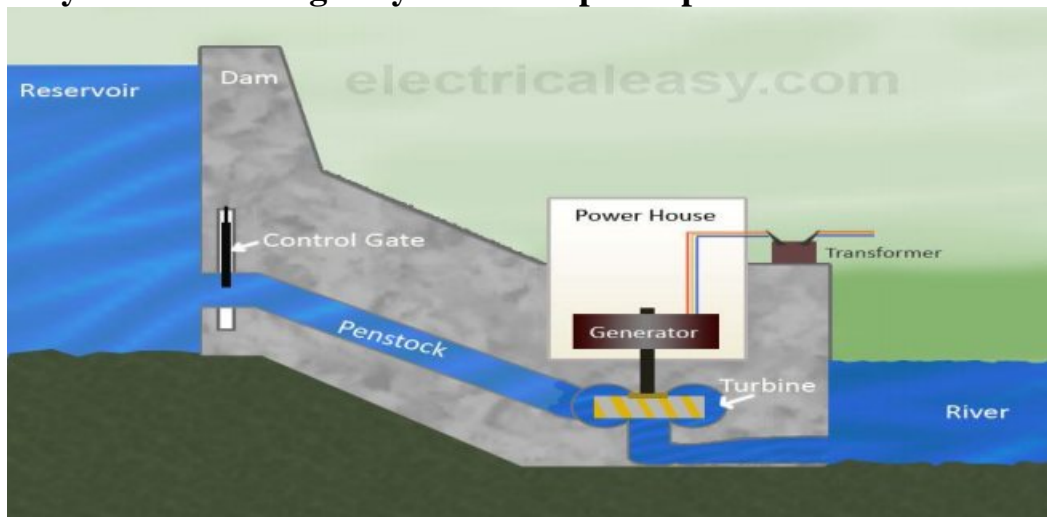

Fig 1.2

1.4.2.1 Dam and Reservoir:

The dam is constructed on a large river in hilly areas to ensure sufficient water storage at height. The dam forms a large reservoir behind it. The height of water level (called as water head) in the reservoir determines how much of potential energy is stored in it.

1.4.2.2 Control Gate:

Water from the reservoir is allowed to flow through the penstock to the turbine. The amount of water which is to be released in the penstock can be controlled by a control gate. When the control gate is fully opened, maximum amount of water is released through the penstock.

1.4.2.3 Penstock:

A penstock is a huge steel pipe which carries water from the reservoir to the turbine. Potential energy of the water is converted into kinetic energy as it flows down through the penstock due to gravity.

1.4.2.4 Water Turbine:

Water from the penstock is taken into the water turbine. The turbine is mechanically coupled to an electric generator. Kinetic energy of the water drives the turbine and consequently the generator gets driven. There are two main types of water turbine; (i) Impulse turbine and (ii) Reaction turbine. Impulse turbines are used for large heads and reaction turbines are used for low and medium heads.

1.4.2.5 Surge Tank:

Surge tanks are usually provided in high or medium head power plants when considerably long penstock is required. A surge tank is a small reservoir or tank which is open at the top. It is fitted between the reservoir and the power house. The water level in the surge tank rises or falls to reduce the pressure swings in the penstock. When there is sudden reduction in load on the turbine, the governor closes the gates of the turbine to reduce the water flow. This causes pressure to increase abnormally in the penstock. This is prevented by using a surge tank, in which the water level rises to reduce the pressure. On the other hand, the **surge tank** provides excess water needed when the gates are suddenly opened to meet the increased load demand.

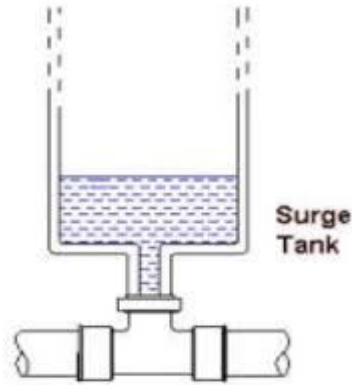

Fig 1.3

1.4.2.6 Generator:

A generator is mounted in the power house and it is mechanically coupled to the turbine shaft. When the turbine blades are rotated, it drives the generator and electricity is generated which is then stepped up with the help of a transformer for the transmission purpose.

1.4.3 Advantages of a hydroelectric power plant

- No fuel is required as kinetic energy of water is converted into electricity energy
- Neat and clean source of energy
- Very small running charges - as water is available with free of cost
- Comparatively less maintenance is required and has longer life
- Serves other purposes too, such as irrigation

1.4.4 Disadvantages

- Very high capital cost due to the construction of dam
- High cost of transmission – as hydro plants are located in hilly areas which are quite away from the consumers

1.5 NUCLEAR POWER PLANT

1.5.1 Working principle

A **nuclear power plant**, heat energy is generated by a nuclear reaction called as **nuclear fission**. Nuclear fission of heavy elements such as Uranium or Thorium is carried out in a special apparatus called as a **nuclear reactor**. A large amount of heat energy is generated due to nuclear fission. Due to fission, a large amount of heat energy is produced which is transferred to the reactor coolant. The coolant may be water, gas or a liquid metal. The heated coolant is made to flow through a heat exchanger where water is converted into high-temperature steam. The generated steam is then allowed to drive a steam turbine. The steam, after doing its work, is converted back into the water and recycled to the heat exchanger. The steam turbine is coupled to an alternator which generates electricity. The generated electrical voltage is then stepped up using a transformer for the purpose of long distance transmission.

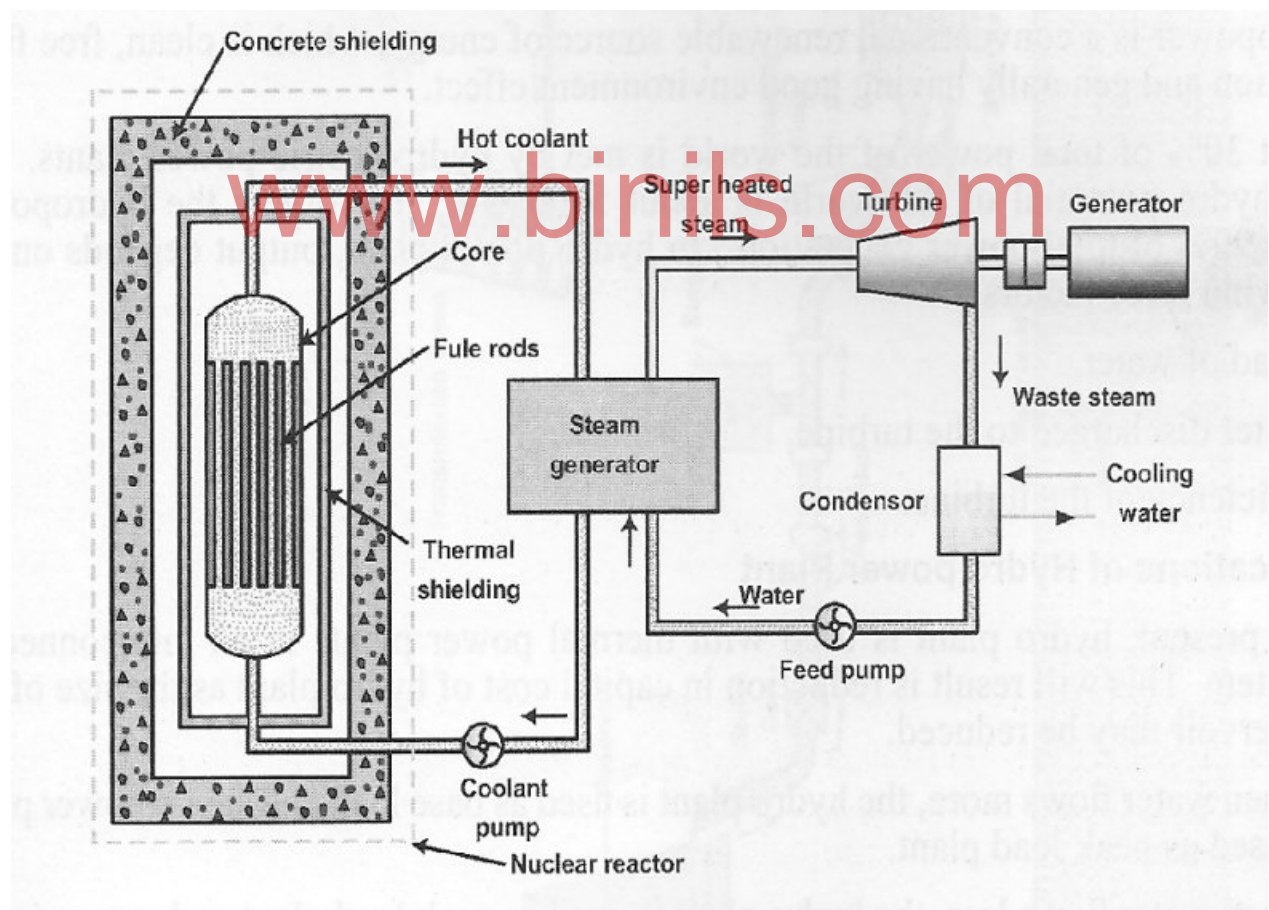

Fig 1.4

1.5.2 Basic Components of a Nuclear Power Plant

1.5.2.1 Nuclear Reactor

A nuclear reactor is a special apparatus used to perform nuclear fission. Since the nuclear fission is radioactive, the reactor is covered by a protective shield. Splitting up of nuclei of heavy atoms is called as nuclear fission, during which huge amount of energy is released. Nuclear fission is done by bombarding slow moving neutrons on the nuclei of heavy element. As the nuclei break up, it releases energy as well as more neutrons which further cause fission of neighboring atoms. Hence, it is a chain reaction and it must be controlled, otherwise it may result in explosion. A nuclear reactor consists of fuel rods, control rods and moderator

1.5.2.2 Fuel:

The fissionable material used in the reactor is called as fuel. The commonly used fuels are Uranium, Plutonium or Thorium. It can be U-235, U-238, Pu-236 or Th-232. Uranium is mostly preferred as it has high melting point.

1.5.2.3 Moderators:

Only neutrons of a fairly low speed should be used to control chain reaction. To slow down the speed fast moving neutrons produced during the fission process, moderators are used. Moderator reduces the speed of the neutron by absorbing its energy but it will not absorb neutron. Graphite, Heavy water and Beryllium are common moderators.

1.5.2.4 Control Rods:

These rods absorb neutrons and stop the chain reaction to proceed further. These are made up of steel containing a high percentage of material like cadmium or boron which can absorb neutrons. When control rods are completely inserted into the moderator block then all the neutrons is absorbed and reaction comes to halt.

1.5.2.5 Two types of nuclear reactors that are widely used –

1. **Pressurized Water Reactor (PWR) -**

This type of reactor uses regular water as coolant. The coolant (water) is kept at very high pressure so that it does not boil. The heated water is transferred through heat exchanger where water from secondary coolant loop is converted into steam. Thus the secondary loop is completely free from radioactive stuff. In a PWR, the coolant water itself acts as a moderator. Due to these advantages, pressurized water reactors are most commonly used.

2. **Boiling Water Reactor (BWR) -**

In this type of reactor only one coolant loop is present. The water is allowed to boil in the reactor. The steam is generated as it heads out of the reactor and then flows through the steam turbine. One major disadvantage of a BWR is that, the coolant water comes in direct contact with fuel

rods as well as the turbine. So, there is a possibility that radioactive material could be placed on the turbine.

1.5.2.6 Heat Exchanger

In the heat exchanger, the primary coolant transfers heat to the secondary coolant (water). Thus water from the secondary loop is converted into steam. The primary system and secondary system are closed loop, and they are never allowed to mix up with each other. Thus, heat exchanger helps in keeping secondary system free from radioactive stuff. Heat exchanger is absent in boiling water reactors.

1.5.2.7 Steam Turbine

Generated steam is passed through a steam turbine, which runs due to pressure of the steam. As the steam is passed through the turbine blades, the pressure of steam gradually decreases and it expands in volume. The steam turbine is coupled to an alternator through a rotating shaft.

1.5.2.8 Alternator

The steam turbine rotates the shaft of an alternator thus generating electrical energy. Electrical output of the alternator is transferred to a step up transformer to transfer it over distances.

1.5.2.9 Condenser

The steam coming out of the turbine, is then converted back into water in a condenser. The steam is cooled by passing it through a third cold water loop.

1.5.2.10 Shielding:

Shielding prevents radiations to reach outside the reactor. Lead blocks and concrete enclosure that is strong enough of several meters thickness are used for shielding.

1.5.2.11 Coolant:

The coolant is substance in a pipe to the steam generator where water is boiled. In this heat-exchange process occurs. Heat is absorbed by the coolant which is produced in the reactor. Typical coolants are water, carbon dioxide gas or liquid sodium.

1.5.2.12 Turbines:

Steam produced in the boiler is now passes to a turbine. The force of the steam jet causes the turbine to rotate. Heat energy (steam) is converted to mechanical energy (moving turbine).

1.5.2.13 Generator:

The generator consists of coils that change the mechanical energy into electric energy. The turbine moves and the change in magnetic flux cause electricity. This is transmitted to substations for distribution of electric power.

1.5.3 Advantages

1. Is environmentally clean - very little greenhouse gas emission.
2. Generates a high amount of electrical energy for the footprint of the power plant.
3. Technology and materials are already exist to build them.
4. Generates less waste than other energy plants (coal, natural gas)
5. Does not use fossil fuel - will decrease our dependency on oil
6. Nuclear power is highly reliable

1.5.4 Disadvantages

1. Generates nuclear waste cannot be dispose of yet only can store away.
2. The consequences of an accident are high.
3. Relies on uranium as a fuel, which is limited in quantities and non renewable.
4. Requires extensive planning and development, so very slow to build.
5. expensive to build and maintain, mainly due to safety precautions needed.
- 6 Uranium is not environmentally friendly

1.6 Comparison of Hydel, Thermal, Nuclear power Plant

STEAM POWER	HYDRO ELECTRIC	NUCLEAR POWER
Located where water and coal and transportation facilities are adequate	Located where large reservoirs or dams can be created like in hilly areas	Located in isolated areas away from population.
Initial cost is lower than hydro and nuclear.	Initial cost pretty high due to large dam construction.	Initial cost is highest as cost of reactor construction is very high.
Running cost is higher than nuclear and hydro due to amount of coal required.	Practically nil as no fuel is required.	Cost of running is low as very very less amount of fuel is required.
Coal is source of power. So limited quantity is available.	Water is source of power which is not a dependable quantity.	Uranium is fuel source along with platinum rods. So sufficient quantity is available.
Cost of fuel transportation is maximum due to large demand for coal.	No cost for fuel transportation	Cost of fuel transportation is minimum due to small quantity required.
Least environment friendly	Most environment friendly	Better friend of environment than steam power plant.
25% overall efficiency.	Around 85% efficient.	More efficient than steam power.
Maintenance cost is very high.	Maintenance cost is quite low.	Maintenance cost is the highest as highly skilled workers are required.
Maximum standby losses as boiler still keep running even though turbine is not.	No standby losses.	Less standby losses.

1.7 DIESEL POWER PLANT

For the generation of the electrical energy, the diesel used as prime mover in the generation station is known as diesel power station.

1.7.1 Components present in the diesel power plant:

- Diesel engine
- Air filters
- Engine starting system
- Fuel system
- Lubrication system
- Cooling system
- Governing system
- Exhaust system

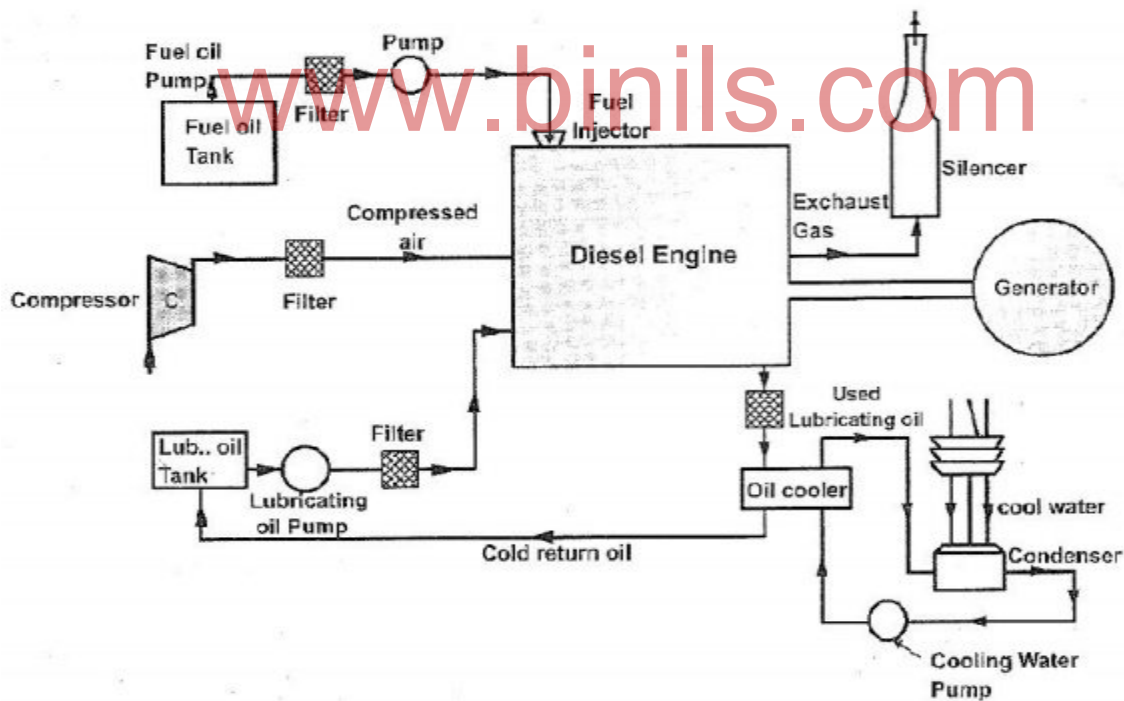

Fig 1.5

1.7.1.1 Diesel engine

Diesel engine is one of the main components present in the diesel power plant. Mainly the engines are classified into two types, They are two stroke engine and four stroke engine. In the diesel engine, the engine is straight away joined to the generator to develop power.

In the engine the air entered in the cylinder must be compressed. Fuel must be injected by the end of the compression stroke. After the burning of the fuel the burnt gases expand and apply pressure on the piston. the shaft of the generator is straightly attached to the engine. After the completion of the combustion the burnt gases are ejected in the atmosphere.

1.7.1.2 Air filters

Air filters are used to remove the dust particles present in the air during the entrance in to the engine. Air filters are a dry air filter type which consists of wool, felt or cloth. In case of the oil bath type filters the air is brushed over a bath of oil so the dust must be elements that get coated.

1.7.1.3 Engine starting system

In the diesel power plant diesel engine used is not a self-starting. Starting of the engine includes the air tanks along with the air compressor. In the cold conditions, the engine is started by delivering the air.

1.7.1.4 Fuel system

The fuel system contains the fuel transfer pump, fuel pump, storage tank, heaters and strainers. With the help of the Pumps the diesel from the storing tank is drawn and with the help of the filter it is supplied to the small day tank. Day tank delivers the day-to-day fuel essential for the engine. In place of the high placed flows the day tank is used so that the diesel movements the engine takes place under gravity. Again the diesel filtered before it is injected into the engine with the help of fuel injection pump.

With the help of the fuel injection system some functions are performs they are

- Initially the fuel must be filtered
- At the time of injection the correct quantity of fuel is to be injected in to the system.
- Injection process must take place at a particular time
- The fuel supply must be regulated
- In the combustion chamber, atomized fuel must be separated properly.
- According to the loads of the plants the fuel must be supplied.

1.7.1.5 Lubrication system

The lubrication system must include oil tanks, coolers, pipes and oil pumps. The main aim of this is used to reduce the friction and reduce tear and wear of the engine components in the moving part. Like cylinder walls and piston. Due to the friction the Lubrication oil must be heated of and the moving parts are cooled earlier reflow. In the lubrication system the oil is forced from the oil tank through the oil chiller. The oil is cooled with the cold water which enters the engine. After cooling of the hot oil the moving parts are returned in to the lubricating oil tank.

1.7.1.6 Cooling system

Inside the engine cylinder the high temperature of the burning fuel is around 1500 to 2000 C. In case we lower this temperature the water is dispersed through the engine. The water jacket covers the engine and the heat from the piston, cylinder, and combustion chamber must be passed by the flowing water. The level of the hot water in the jacket is delivered through the heat exchanger. In the heat exchanger, the heat is carried away by the water which is circulated over the heat exchanger and the water is cooled in the cooling tower

1.7.1.7 Governing system

The governing system is used to control the speediness of the engine. This is completed by changing the fuel stream permitting it to the engine load

1.7.1.8 Exhaust system

The exhaust gases approaching out of the engine are very loud. To reduce the sound a silencer is used.

1.8 GAS TURBINE POWER PLANT

A generating station which employs gas turbine as the prime mover for the generation of electrical energy is known as a gas turbine power plant. In a gas turbine power plant, air is used as the working fluid. The air is compressed by the compressor and is led to the combustion chamber where heat is added to air, thus raising its temperature. Heat is added to the compressed air either by burning fuel in the chamber or by the use of air heaters. The hot and high pressure air from the combustion chamber is then passed to the gas turbine where it expands and does the mechanical work. The gas turbine drives the alternator which converts mechanical energy into electrical energy.

It may be mentioned here that compressor, gas turbine and the alternator are mounted on the same shaft so that a part of mechanical power of the turbine can be utilized for the operation of the compressor. Gas turbine power plants are being used as standby plants for hydro-electric stations, as a starting plant for driving auxiliaries in power plants etc.

1.8.1 Schematic arrangement of a gas turbine power plant:

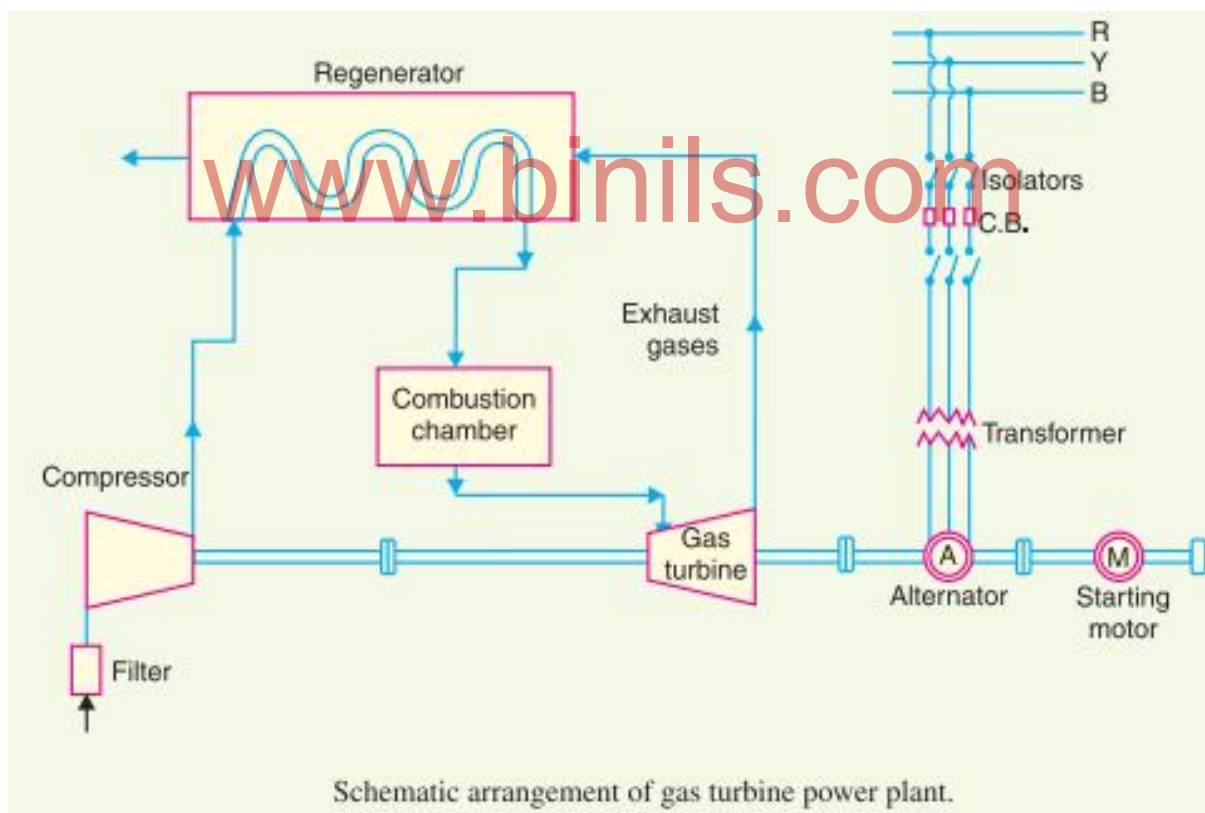

Fig 1.6

1.8.2 The main components of the plant are :

- (i) Compressor
- (ii) Regenerator
- (iii) Combustion chamber
- (iv) Gas turbine
- (v) Alternator
- (vi) Starting motor

1.8.2.1 Compressor:

The compressor used in the plant is generally of rotator type. The air at atmospheric pressure is drawn by the compressor through the filter which removes the dust from air. The rotatory blades of the compressor push the air between stationary blades to raise its pressure. Thus air at high pressure is available at the output of the compressor.

1.8.2.2 Regenerator:

A regenerator is a device which recovers heat from the exhaust gases of the turbine. The exhaust is passed through the regenerator before wasting to atmosphere. A regenerator consists of a nest of tubes contained in a shell. The compressed air from the compressor passes through the tubes on its way to the combustion chamber. In this way, compressed air is heated by the hot exhaust gases.

1.8.2.3 Combustion chamber:

The air at high pressure from the compressor is led to the combustion chamber via the regenerator. In the combustion chamber, heat is added to the air by burning oil. The oil is injected through the burner into the chamber at high pressure to ensure atomization of oil and its thorough mixing with air. The result is that the chamber attains a very high temperature (about 3000 F). The combustion gases are suitably cooled to 1300 F to 1500F and then delivered to the gas turbine.

1.8.2.4 Gas turbine:

The products of combustion consisting of a mixture of gases at high temperature and pressure are passed to the gas turbine. These gases in passing over the turbine blades expand and thus do the mechanical work. The temperature of the exhaust gases from the turbine is about 900F.

1.8.2.5 Alternator:

The gas turbine is coupled to the alternator. The alternator converts mechanical energy of the turbine into electrical energy. The output from the alternator is given to the bus-bars through transformer, circuit breakers and isolators.

1.8.2.6 Starting motor:

Before starting the turbine, compressor has to be started. For this purpose, an electric motor is mounted on the same shaft as that of the turbine. The motor is energized by the batteries. Once the unit starts, a part of mechanical power of the turbine drives the compressor and there is no need of motor now.

1.8.3 Advantages of Gas turbine power plant:

- (i) It is simple in design
- (ii) It is much smaller in size as compared to steam power station of the same capacity.
- (iii) The initial and operating costs are much lower than that of equivalent steam power station.
- (iv) It requires comparatively less water as no condenser is used.
- (v) The maintenance charges are quite small.
- (vi) Gas turbines are much simpler in construction and operation than steam turbines.
- (vii) It can be started quickly from cold conditions.

1.8.4 Disadvantages of Gas turbine power plant:

- (i) There is a problem for starting the unit. It is because before starting the turbine; the compressor has to be operated for which power is required from some external source.
- (ii) For driving compressor greater part of power developed by the turbine is used, the net output is low.
- (iii) The overall efficiency of such plants is low (about 20%) because the exhaust gases from the turbine contain sufficient heat.
- (iv) The temperature of combustion chamber is quite high (3000F) so that its life is comparatively reduced.

1.9 PUMPED STORAGE PLANT

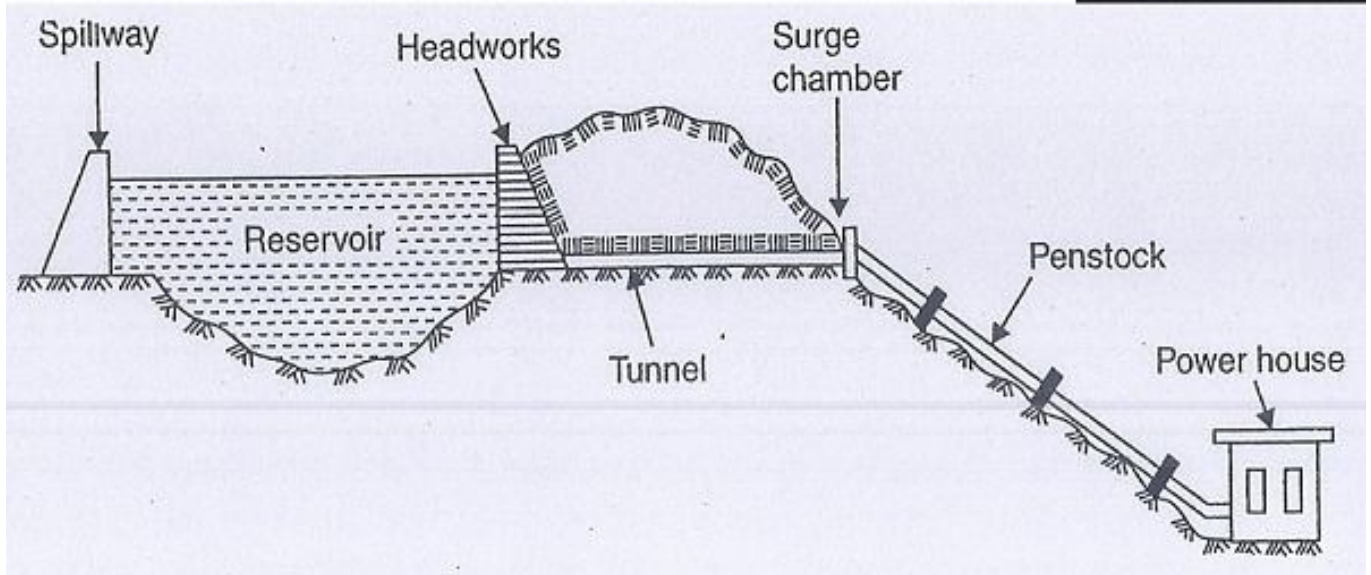

Fig 1.7

www.binils.com

1.9.1 Construction and working principle of pumped storage plants

Pumped storage plants are employed at the places where the quantity of water available for power generation is inadequate. Here the water passing through the turbines is stored in a tail race pond. During low load periods this water is pumped back to the head reservoir using the extra energy available. This water can be again used for generating power during peak load periods. Pumping of water may be done seasonally or daily depending upon the conditions of the site and the nature of the load on the plant.

A pumped storage plant has two separate reservoirs, an upper and a lower one. When electricity is in low demand, for example at night, water is pumped into the upper reservoir. When there is a sudden demand for power, giant taps known as the head gates are opened.

This allows water from the upper reservoir to flow through pipes, powering a turbine, into the lower reservoir. The movement of the turbine turns a generator which creates electricity. The electricity is generated in the generator by using powerful magnets and coils of wire. When the coils are spun quickly inside the magnets, they produce electricity.

Water exiting from the pipe flows into the lower reservoir rather than re-entering a river and flowing downstream. At night, the water in the lower reservoir can be pumped back up into the upper reservoir to be used again.

1.9.2 Advantages:

1. There is substantial increase in peak load capacity of the plant at comparatively low capital cost.
2. The operating efficiency of the plant is high.
3. There is an improvement in the load factor of the plant.
4. The energy available during peak load periods is higher than that of during off peak periods so that inspite of losses incurred in pumping there is over-all gain.
5. Load on the hydro-electric plant remains uniform.
6. The hydro-electric plant becomes partly independent of the stream flow conditions.

1.10 RENEWABLE ENERGY

It is generally defined as **energy** that is collected from resources which are naturally replenished on a human timescale, such as sunlight, wind, rain, tides, waves, and geothermal heat.

www.binils.com

1.11 SOLAR ENERGY

When sunlight strikes on photo-voltaic solar cells, **solar energy** is produced. This is also known as Photo Voltaic Solar, or PV Solar.

1.11.1 Principles of Solar Energy

Generation of electricity by using **solar energy** depends on the photo voltaic effect. In photo voltaic effect, semiconductor p n junction produces electric potential when it is exposed to sunlight. For that purpose, we make n type semiconductor layer of the junction very thin. It is less than 1 μm thick. The top layer is n layer. We generally refer it as emitter of the cell. The bottom layer is p type semiconductor layer and it is much thicker than top n layer. It may be more than 100 μm thick. We call this bottom layer as base of the cell. The depletion region is created at the junction of these two layers due to immobile ions. When sunlight strikes on the cell, it easily reaches up to p n junction. The p n junction absorbs the photons of sunlight ray and consequently, produces electrons holes pairs in the junction. Actually, the energy associated with photon excites the valence electrons of the semiconductor atoms and hence the electrons jump to the conduction band from valence band leaving a hole behind each.

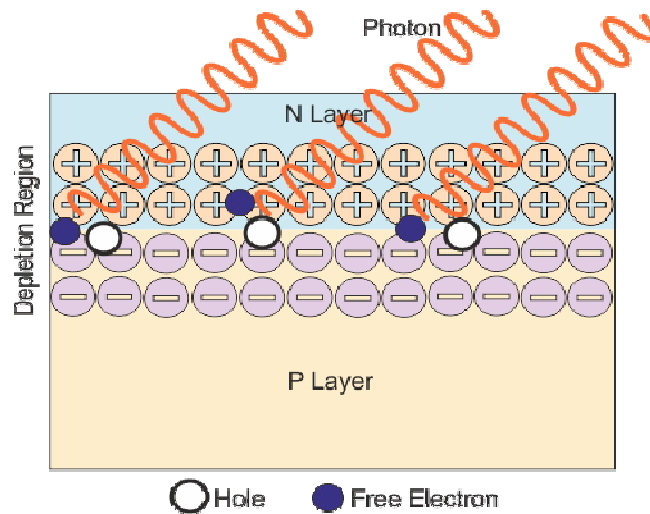

Fig 1.8

The free electrons, find themselves in the depletion region will easily pass to the top n layer because of attraction force positive ions in the depletion region. In the same way the holes find themselves in the depletion region will easily pass to the bottom p layer because of attraction force of negative ions in the depletion region. This phenomenon creates a charge difference between the layers and resulting to a tiny potential difference between them. The unit of such combination of n type and p type semiconductor materials for producing electric potential difference in sunlight is called solar cell. Silicon is normally used as the semiconductor material for producing such solar cell.

1.11.2 Simplified Grid Connected PV System

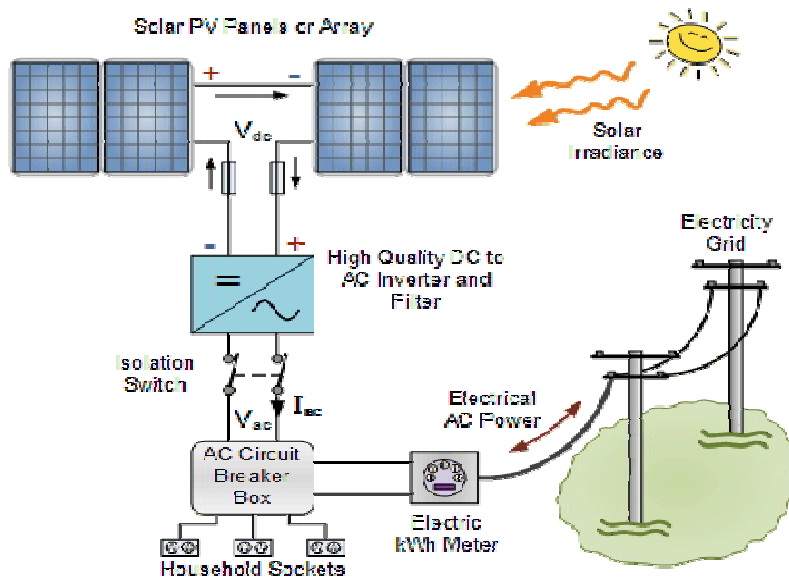

Fig 1.9

Grid connected PV systems always have a connection to the public electricity grid via a suitable inverter because a photovoltaic panel or array (multiple PV panels) only delivers DC power. As well as the solar panels, the additional components that make up a grid connected PV system compared to a standalone PV system are:

- **Inverter:**

The inverter is the most important part of any grid connected system. The inverter extracts as much DC (direct current) electricity as possible from the PV array and converts it into clean mains AC (alternating current) electricity at the right voltage and frequency for feeding into the grid or for supplying domestic loads.

- **Electricity Meter:**

The electricity meter also called a Kilowatt hour (kWh) meter is used to record the flow of electricity to and from the grid. Twin kWh meters can be used, one to indicate the electrical energy being consumed and the other to record the solar electricity being sent to the grid. A single bidirectional kWh meter can also be used to indicate the net amount of electricity taken from the grid. A grid connected PV system will slow down or halt the aluminum disc in the electric meter and may cause it to spin backwards. This is generally referred to as net metering.

- **AC Breaker Panel and Fuses:**

The breaker panel or fuse box is the normal type of fuse box provided with a domestic electricity supply and installation with the exception of additional breakers for inverter and/or filter connections.

- **Safety Switches and Cabling:**

A photovoltaic array will always produce a voltage output in sunlight so it must be possible to disconnect it from the inverter for maintenance or testing. Isolator switches rated for the maximum DC voltage and current of the array and inverter safety switches must be provided separately with easy access to disconnect the system. Other safety features demanded by the electrical company may include earthing and fuses. The electrical cables used to connect the various components must also be correctly rated and sized.

- **The Electricity Grid:**

Finally the electricity grid itself to connect too, because without the utility grid it is not a Grid Connected PV System.

A grid connected system without batteries is the simplest and cheapest solar power setup available, and by not having to charge and maintain batteries they are also more efficient. It is important to note that a grid connected solar power system is not an independent power source unlike a stand alone system. Should the mains supply from the electrical grid be interrupted, the lights may go out, even if the sun is shining. One way to overcome this is to have some form of short term energy storage built into the design.

1.11.3 Standalone solar PV system

The system which utilizes only solar electric energy as main source of energy is referred as **standalone solar electrical system**. There are many locations on this earth where no source of electricity is available. At these locations standalone solar electrical system can be the ideal source of electricity. The main advantage of this system is that it does not depend on grid or any other source of electricity. As it does not have any connection with grid or other electric supply line, it is also known as off-grid photovoltaic system. As the sun is the only source of energy in this system it should have some means to make it active even in nighttimes. A storage battery system does the job. Therefore, a storage battery system is an essential component of standalone solar system. But, often this battery system can be omitted from the system if the system is dedicated for the load which to be operated in day times only. Popular examples of standalone solar system are solar lanterns, solar home lighting systems, solar water pumping systems, etc.

Types of Standalone Solar Systems

Depending upon the use and design there are different types of standalone solar systems.

1. Standalone Solar (PV) system with only DC load
2. Standalone Solar (PV) system with DC load and Electronics control circuitry
3. Standalone Solar (PV) system with DC load, Electronics control circuitry and Battery
4. Standalone Solar (PV) system with AC/DC load, Electronics control circuitry and Battery.

1.11.4 HYBRID SOLAR PV SYSTEM

Hybrid solar power systems are the combination of two different power generation system, they are solar PV and another power generating energy source.

IMPLEMENTATION OF HYBRID ENERGY SYSTEM

Intermittent energy resources and energy resources unbalance are the most important reason to install a hybrid energy supply system. The Solar PV and wind hybrid system suits to conditions where sunlight and wind has seasonal shifts. As the wind does not blow throughout the day and the sun does not shine for the entire day, using a single source will not be a suitable choice. A hybrid arrangement of combining the power harnessed from both the wind and the sun and stored in a battery can be a much more reliable and realistic power source. The load can still be powered using the stored energy in the batteries even when there is no sun or wind. Hybrid systems are usually built for design of systems with lowest possible cost and also with maximum reliability. The high cost of solar PV cells makes it less competent for larger capacity designs. This is where the wind turbine comes into the picture, the main feature being its cheap cost as compared to the PV cells. Battery system is needed to store solar and wind energy produced during the day time. During night time, the presence of wind is an added advantage,

which increases the reliability of the system. In the monsoon seasons, the effect of sun is less at the site and thus it is apt to use a hybrid wind solar system.

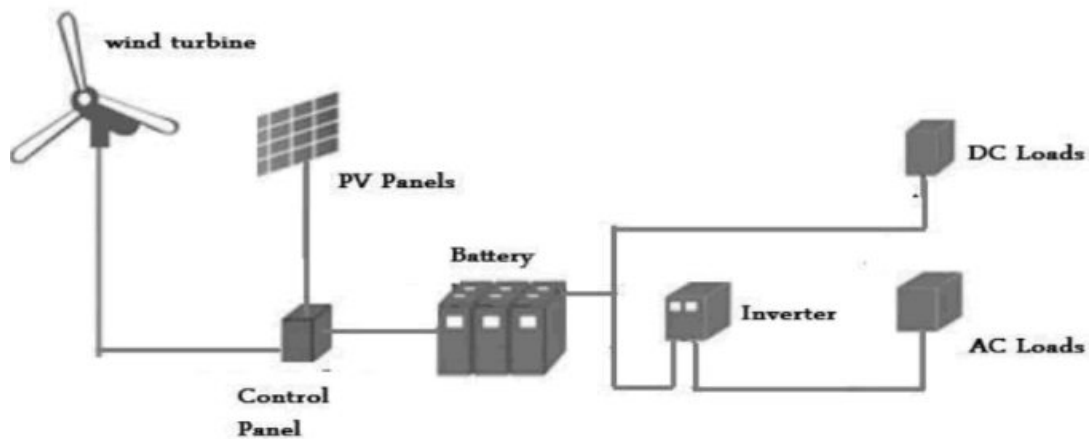

Fig 1.10

The system components are as follows.

- **Photovoltaic solar power**

Solar panels are the medium to convert solar energy into the electrical energy. Solar panels can convert the energy directly or heat the water with the induced energy. PV (Photo-voltaic) cells are made up from semiconductor structures as in the computer technologies. Sun rays are absorbed with this material and electrons are emitted from the atoms. This release activates a current. Photovoltaic is known as the process between radiation absorbed and the electricity induced. Solar power is converted into the electric power by a common principle called photo electric effect. The solar cell array or panel consists of an appropriate number of solar cell modules connected in series or parallel based on the required current and voltage.

- **Wind Power**

The wind energy is a renewable source of energy. Wind turbines are used to convert the wind power into electric power. Electric generator inside the turbine converts the mechanical power into the electric power. Wind turbine systems are available ranging from 50W to 3-4 MW. The energy production by wind turbines depends on the wind velocity acting on the turbine. Wind power is able to feed both energy production and demand in the rural areas. It is used to run a windmill which in turn drives a wind generator or wind turbine to produce electricity.

- **Batteries**

The batteries in the system provide to store the electricity that is generated from the wind or the solar power. Any required capacity can be obtained by serial or parallel connections of the batteries. The battery that provides the most advantageous operation in the solar and wind power systems are

maintenance free dry type and utilizes the special electrolytes. These batteries provide a perfect performance for long discharges.

- **Inverter**

Energy stored in the battery is drawn by electricals loads through the inverter, which converts DC power into AC power. The inverter has in-built protection for Short-Circuit, Reverse Polarity, Low Battery Voltage and Over Load.

- **Microcontroller**

The microcontroller compares the input of both Power system and gives the signal to the particular relay and charges the DC Battery. The DC voltage is converted into AC Supply by Inverter Circuit. The MOSFET (IRF 540) is connected to the Secondary of the centre tapped transformer. By triggering of MOSFET alternatively, the current flow in the Primary winding is also alternative in nature and we get the AC supply in the primary winding of the transformer.

1.12 WIND POWER STATION

1.12.1 Wind energy

The terms "wind energy" or "wind power" describe the process by which the wind is used to generate mechanical power or electricity. Wind turbines convert the kinetic energy in the wind into mechanical power. This mechanical power can be used for specific tasks (such as grinding grain or pumping water) or a generator can convert this mechanical power into electricity

1.12.2 Schematic arrangement of wind power plant

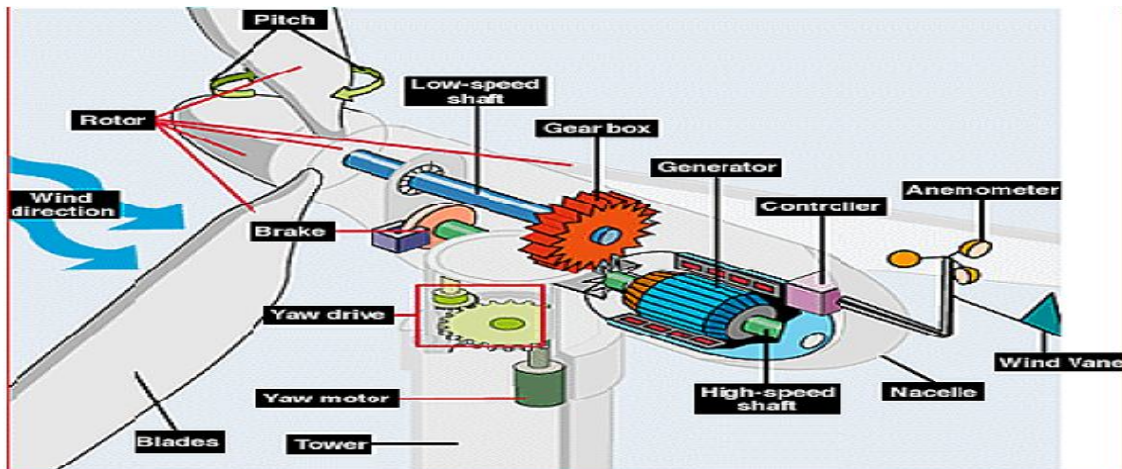

Fig 1.11

Basic Components of a wind Power Plant

1.12.2.1 Tower

Tower is very crucial part of wind turbine that supports all the other parts. It is not only support the parts but raise the wind turbine so that its blades safely clear the ground and so it can reach the stronger winds at higher elevations. The height of tower depends upon the power capacity of wind turbines. Larger turbines usually mounted on tower ranging from 40 meter to 100 meter.

1.12.2.2 Nacelle

Nacelle is big box that sits on the tower and house all the components in a wind turbine. It houses Power Converter, Shaft, Gearbox, Generator, Turbine controller, Cables, Yaw drive.

1.12.2.3 Rotor Blades

Blades are the mechanical part of wind turbine that converts wind kinetic energy into mechanical energy. When the wind forces the blades to move, it transfers some of its energy to the shaft. Blades are shaped like airplane wings blades can be as long as 150 feet.

1.12.2.4 Shaft

The shaft is connected to the rotor. When the rotor spins, the shaft spins as well. In this way, the rotor transfers its mechanical, rotational energy to shaft which enters an electrical generator on the other end.

1.12.2.5 Gearbox

The rotor turns the shaft at low speed ex. 20 rpm but to generate electricity, generator needs higher speed. Gearbox increases the speed to much higher value required by most generators to produce electricity. For example, if Gearbox ratio is 1:80 and if rotor speed is 15 rpm then gearbox will increase the speed to $15 \times 80 = 1200$ rpm that is given to generator shaft.

1.12.2.6 Generator

Generator is electrical device that converts mechanical energy received from shaft into electrical energy. It works on electromagnetic induction to produce electrical voltage or electrical current. A simple generator consists of magnets and a conductor. The conductor is typically a coiled wire. Inside the generator shaft connects to an assembly of permanent magnets that surrounded by magnets and one of those parts is rotating relative to the other, it induce the voltage in the conductor. When the rotor spins to the shaft, the shaft spins the assembly of magnets and generate voltage in the coil of wire.

1.12.2.7 Power Converter

Because wind is not always constant so electrical potential generated from generator is not constant but we need a very stable voltage to feed the grid. Power converter is an electrical device that stabilizes the output alternating voltage transferred to the grid.

1.12.2.8 Anemometer

It measures the wind speed and passes the speed information to PLC to control the turbine power.

1.12.2.9 Wind Vane

It senses the direction of wind and passes the direction to PLC then PLC faces the blades in such a way that it cuts the maximum wind.

1.12.2.10 Pitch Drive

Pitch drive motors control the angle of blades whenever wind changes it rotates the angle of blades to cut the maximum wind, which is called pitching of blades.

1.12.2.11 Yaw Drive

Blades and other components in wind turbine is housed in Nacelle, whenever any change in wind direction is there Nacelle has to move in the direction of wind to extract the maximum energy from wind. For this purpose yaw drive motor is used to rotate the nacelle. It is controlled by PLC that uses the wind vane information to sense the wind direction.

1.12.3 Working principle

When the wind strikes the rotor blades, blades start to rotating. Rotor is directly connected to high speed gearbox. Gearbox converts the rotor rotation into high speed which rotates the electrical generator. An exciter is needed to give the required excitation to the coil so that it can generate required voltage. The exciter current is controlled by a turbine controller which senses the wind speed based on that it calculate the power what we can achieve at that particular wind speed.

Then output voltage of electrical generator is given to a rectifier and rectifier output is given to line converter unit to stabilize the output ac that is feed to the grid by a high voltage transformer. An extra units is used to give the power to internal auxiliaries of wind turbine (like motor, battery etc.), this is called Internal Supply unit. SU can take the power from grid as well as from wind. Chopper is used to dissipate extra energy from the RU for safety purpose. Internal Block diagram of wind turbine

1.12.4 Advantages of Wind Energy

1. Wind energy is eco-friendly
2. Wind energy is relatively inexpensive
3. Wind energy has enabled electricity reach in remote locations
4. It's a steady and reliable source of electricity

5. Wind turbines take up less space
6. Wind energy contribute to job creation

1.12.5 Disadvantages of Wind Energy

1. Wind energy is variable
2. Turbine blades can pose great danger to local bird species
3. The initial infrastructure is costly

1.13 Inter connected system

An **electrical grid** is an interconnected network for delivering electricity from suppliers to consumers. It consists of generating stations that produce electrical power, high voltage transmission lines that carry power from distant sources to demand centers, and distribution lines that connect individual customers.

1.13.1 Interconnected Grid system advantages

- The function of generating station is to provide power to a large number of consumers. But consumer's power requirement will vary as per their activities.
- Due to this variation in demand, the load on a power station is never constant and it varies from time to time.
- We know the fact that electrical power can not be stored.
- The power generating stations must produce power as and when demanded to meet the requirements of the consumers.
- On the other hand, to get maximum efficiency the alternators in the power station have to run at rated capacity.
- In order to meet both varying demands of the consumers and get maximum efficiency from the power station the prime station (steam, thermal, hydraulic power plants) are connected with small power plants (like biogas, solar, wind etc).

The connection of several generating stations in parallel is known as *interconnected grid system*. Even though this arrangement adds extra cost, it gives huge benefits. So now a day it is widely used. Some of the advantages of interconnected Grid System are given below;

1. Exchange of peak loads
2. Use of older plants
3. Ensures economical operation
4. Increases diversity factor
5. Reduces plant reserve capacity

6. Increases reliability of supply

Let us discuss each of the advantages in detail

(i) Exchange of peak loads

- An important advantage of interconnected system is that the peak load of the power station can be exchanged.
- If the load curve of a power station shows a peak demand that is greater than the rated capacity of the plant, then the excess load can be shared by other stations interconnected with it.

(2) Use of Older Plants:

- The interconnected grid system makes it possible to use the older and less efficient plants to carry peak loads of short durations.
- Even though such plants may be inadequate when used alone, they have sufficient capacity to carry short peaks of loads when interconnected with other modern plants.

(3) Ensures economical operation:

- The interconnected grid system makes the operation of concerned power stations quite economical.
- It is because sharing of load among the stations is arranged in such a way that more efficient stations work continuously throughout the year at a high load factor and the less efficient plants work for peak load hours only.

(4) Increases diversity factor:

- The load curves of different interconnected stations are generally different.
- The result is that the maximum demand on the system is much reduced as compared to the sum of individual maximum demands of different stations.
- In other words, the diversity factor of the system is improved, so increasing the effective capacity of the system.

(5) Reduces plant reserve capacity:

- Every power station is required to have a standby unit for emergencies.
- But when several power stations are connected in parallel, the reserve capacity of the grid system is reduced drastically. This increases the efficiency of the system.

(6) Increases reliability of supply:

- The interconnected system increases the reliability of supply.
- If a major breakdown occurs in one station, continuity of the supply can be maintained by other healthy stations.

1.14 Load Curve

A load curve is a graphical record showing the power demands for every instant during a certain time interval.

Such a record may cover 1 hour, in which case it would be an hourly load graph, a month in which case it would be a monthly load graph, or a year (7860 hours), in which case it would be a yearly load graph.

1.14.1 Significance of Load Curves:

- (i) The area under the load curve represents the energy generated in the period considered.
- (ii) The area under the curve divided by the total number of hours gives the average load on the power station.
- (iii) The peak load indicated by the load curve/graph represents the maximum demand of the power station.
- (iv) Load curves give full information about the incoming and help to decide the installed capacity of the power station and to decide the economical sizes of various generating units.

These curves also help to estimate the generating cost and to decide the operating schedule of the power station, i.e. the sequence in which different units should be run.

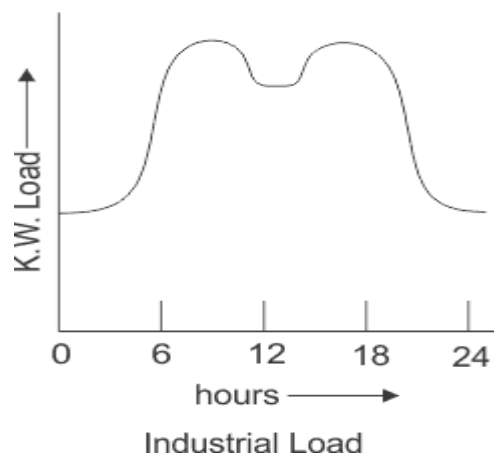

1.15 Load Duration Curve

1.15.1 Definition:

The load duration curve is defined as the curve between the load and time in which the ordinates representing the load, plotted in the order of decreasing magnitude, i.e., with the greatest load at the left, lesser loads towards the rights and the lowest loads at the time extreme right.

This curve represents the same data as that of the load curve. The load duration curve is constructed by selecting the maximum peak points and connecting them by a curve.

The load duration curve plotting for 24 hours of a day is called the daily load duration curve. Similarly, the load duration curve plotted for a year is called the annual load curve.

$$\text{Average Demand} = \frac{\text{kWh (or MWh) consumed in a given period of time}}{\text{hours in the time period}}$$

$$\text{Average Demand} = \frac{\text{area under the load duration curve}}{\text{base of the load duration curve}}$$

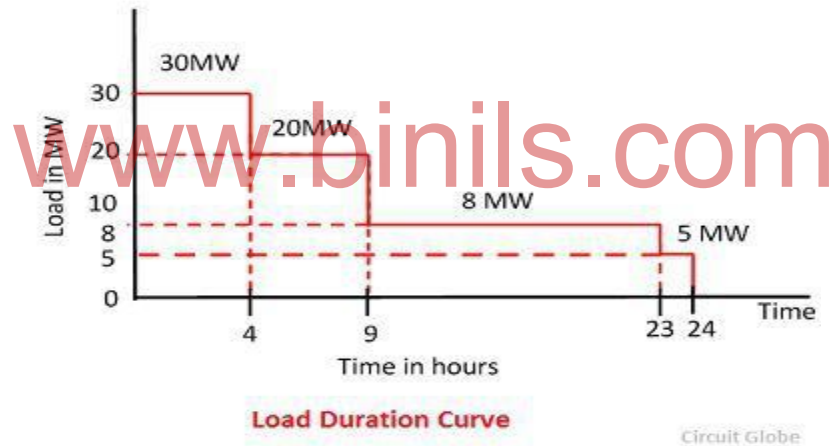

1.15.2 Information Available Form Load Duration Curve

1. The load duration curve gives the minimum load present throughout the specified period.
2. It authorizes the selection of base load and peak load power plants.
3. Any point on the load duration curve represents the total duration in hours for the corresponding load and all loads of greater values.
4. The area under the load duration curve represents the energy associated with the load duration curve.

- The average demand during some specified time periods such as a day or a month can be obtained from the load duration curve.

1.16 Important terms

1.16.1 Connected Load

The total connected electric power rating of all devices (lamps or motors) in a distribution system.

1.16.2 Maximum Demand

It is the greatest demand of load on the power station during a given period. I.e. The maximum of all the demands that have occurred during a given period (may be a day, may be an hour etc.).

1.16.3 Demand factor

The ratio of max.demand on the power station to its connected load. It usually less than 1. Maximum demand on power station is less than connected load.

$$\text{Demand factor} = \frac{\text{Maximum demand}}{\text{Connected load}}$$

1.16.4 Load Factor

The load factor is the ratio of the average power to the maximum demand.

$$\text{load factor} = \frac{\text{Average power}}{\text{Maximum demand}}$$

• Significance of Load Factor

Load factor basically gives an idea of cost of per unit power generation. How?

$$\text{As } \text{Load Factor} = \text{Average Load} / \text{Maximum Demand}$$

We can write it for a period of T hrs as below,

$$\begin{aligned} \text{Load Factor} &= \text{Average Load} \times T / \text{Maximum Demand} \times T \\ &= \text{Units generated in T hrs} / \text{Maximum Demand} \times T \end{aligned}$$

Thus a higher value of load factor means, less maximum demand. Less maximum demand can be catered by a low capacity power plant. As the capacity of plant is less, this means the initial as well as running cost will be low. Thus the cost per unit power generation will be less.

Again, in other sense higher value of load factor means higher Average Load. This means the plant is operating near its rated capacity. Therefore the cost of per unit power generation will be less.

1.16.5 Diversity factor

Diversity factor is the ratio of the sum of the individual maximum demands of the various subdivisions of a system to the maximum demand of the whole system (or part of the system) under consideration.

Diversity is usually more than one.

$$\text{Diversity factor} = \frac{\text{Sum of individual maximum demands}}{\text{Maximum demand of entire group}}$$

1.16.6 Average load

The average demand or average load is defined as the total energy delivered in a certain period divided by the time interval. It is possible to calculate a daily average load, weekly average load, monthly average load.

1.16.7 Plant capacity factor

The net capacity factor of a power plant is the ratio of its actual output over a period of time, to its potential output if it were possible for it to operate at full nameplate capacity continuously over the same period of time.

$$\text{Capacity Factor} = \frac{\text{Actual Energy Generated}}{\text{Maximum Energy that could be Generated}}$$

1.16.8 Base load

Base load is the minimum level of electricity demand required over a period of 24 hours. It is needed to provide power to components that keep running at all times (also referred as continuous load).

1.16.9 Peak load

Peak load is the high demand at a time. These peaking demands are often for only shorter durations. Peak demand could be understood as the difference between the base demand and the highest demand.

1.17 Base Load Power plants

Plants that are running continuously over extended periods of time are said to be base load power plant. The power from these plants is used to cater the base demand of the grid. A power plant may run as a base load power plant due to various factors (long starting time requirement, fuel requirements, etc.).

Examples of base load power plants are:

1. Nuclear power plant
2. Coal power plant
3. Hydroelectric plant
4. Geothermal plant
5. Biogas plant
6. Biomass plant
7. Solar thermal with storage
8. Ocean thermal energy conversion

1.18 Peak Load Power plants

To cater the peak demand , peak load power plants are used. They are started up whenever there is a spike in demand and stopped when the demand recedes.

Examples of gas load power plants are:

1. Gas plant
2. Solar power plants
3. Wind turbines
4. Diesel generators

1.19 Load dispatching

A power station generates electrical power. The generated power has many characteristics such as voltage, frequency, load etc. Most of the power stations are operated and connected to a grid, The load on the grid varies with respect to time and human activity. The generation has to be controlled to meet the demand of load and frequency. Different stations use different fuel. Based on the demand from the grid Generation has to be controlled. At the same time, problems inside the plant may restrict the generation. The load dispatcher controls these things

REVIEW QUESTION

2 MARKS & 3 MARKS

1. State the conventional source of power generation
2. List out the different renewable energy sources.
3. State the non renewable energy sources of power generation
4. State any two advantage of Hydel power plant
5. State any two advantage of nuclear power plant
6. State any two advantage of thermal power plant
7. Give two uses of load curve
8. State the advantage of gas power plant?
9. What is diversity factor?
10. What are the advantages of gas power plant?
11. What is diversity factor?
12. What is stand alone system?
13. What are the applications of solar power plant?
14. What is load curve?
15. What is load curve duration?
16. What is demand factor?
17. What is maximum demand?
18. What is plant capacity factor?
19. What is a grid system?
20. What is base load plant?
21. What is peak load?
22. List the advantage of interconnected grid system.
23. What is diversity factor?
24. What is cogeneration?
25. What is interconnected system?

10 MARKS

1. Explain the principal of tidal energy.
2. What is load curve? Give the uses of load curve.
3. What are the conventional sources of power generation?
4. Distinguish load curve and load duration curve.
5. What is base load and peak load plant? Give two examples for each power plant?
6. What are the points to be consider for the selection of sites for a thermal power station? state the merits and demerits.
7. Draw and explain the schematic diagram of thermal power plant?
8. Draw and explain the schematic diagram of Hydel power plant?
9. Draw and explain the schematic diagram of diesel power plant?
10. Draw and explain the schematic diagram of nuclear power plant?
11. Draw and explain the schematic diagram of gas power plant?
12. Explain with neat sketch the various part of nuclear reactor.
13. What are the advantages of interconnected system?
14. Explain the load sharing between base and peak load?
15. Compare the thermal, hydro, nuclear power plant.
16. Explain the working and application of solar power plant.
17. Explain the principle and operation of wind power plant.
18. Explain the principle and operation of geo thermal power plant.
19. Explain the principle and operation of MHD Power plant and state its advantage.

Unit –II

A.C. AND H.V.D.C TRANSMISSION

A.C. Transmission:

2. Introduction

In early days, there was a little demand for electrical energy so that small power stations were built to supply lighting and heating loads. However, the widespread use of electrical energy by modern civilization has necessitated producing bulk electrical energy economically and efficiently. The increased demand of electrical energy can be met by building big power stations at favorable places where fuel (coal or gas) or water energy is available in abundance. This has shifted the site of power stations to places quite away from the consumers. The electrical energy produced at the power stations has to be supplied to the consumers. There is a large network of conductors between the power station and the consumers. This network can be broadly divided into two parts *viz.*, transmission and distribution. The purpose of this chapter is to focus attention on the various aspects of transmission of electric power.

2.1 Typical Layout of A.C. Power supply scheme

The transmission network between Generating Station (Power Station) and consumer of electric power can be divided into two parts.

- Transmission System
- Distribution System

We can explore these systems in more categories such as Primary transmission and secondary transmission. Similarly primary distribution and secondary distribution. This is shown in the below image (One Line or Single Line diagram of Typical AC power System Scheme).

It is not necessary that the entire steps which are shown in the above image must be included in the other power schemes. There may be difference. For example, there is no secondary transmission in many schemes, in some (small) schemes there is no transmission, but only distribution.

The following parts of a typical power supply scheme are shown in figure 2.1

1. Generating Station
2. Primary transmission
3. Secondary transmission
4. Primary Distribution
5. Secondary Distribution

2.1.1 Generating Station:

The place where electric power produced by the parallel connected three phase alternators/generators is called Generating Station (i.e. power plant). The Ordinary power plant capacity and generating voltage may be 11kV, 11.5 kV 12kV or 13kV. But economically, it is good to

step up the produced voltage from (11kV, 11.5kV Or 12 kV) to 132kV, 220kV or 500kV or greater (in some countries, up to 1500kV) by Step up transformer (power Transformer).

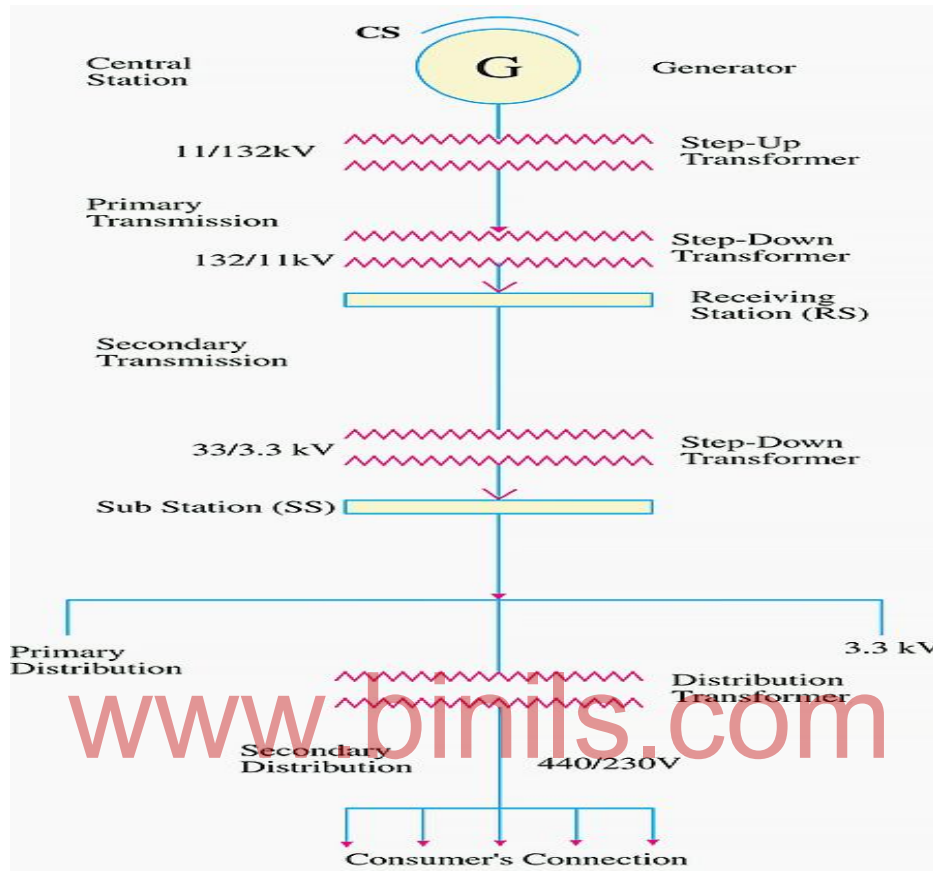

Figure 2.1

2.1.2 Primary Transmission:

The electric supply (in 132kV, 220 kV, 500kV or greater) is transmitted to load center by three phase three wire (3 Phase – 3 Wires) overhead transmission system.

2.1.3 Secondary Transmission:

Area away from city (outskirts) which have been connected with receiving station by line is called Secondary transmission. At receiving station, the level of voltage is reduced by step-down transformers up to 132kV, 66 or 33 kV, and Electric power is transmitted by three phase three wire (3 Phase – 3 Wires) overhead system to different sub stations. this is called Secondary Transmission.

2.1.4 Primary Distribution:

At a substation, the level of secondary transmission voltage is further(132kV, 66 or 33 kV) reduced to 11kV by step down transformers.

Generally, heavy consumer receives from step down transformer as 11 kV used in primary distribution (in three phase three wire overhead system) and they have a separate substation to control and utilize this power.

In other cases, for heavier consumer (at large scale) their demand is about 132 kV or 33 kV. they take electric supply from secondary transmission or primary distribution (in 132 kV, 66kV or 33kV) and then step down the level of voltage by step-down transformers in their own sub station for utilization (i.e. for electric traction etc).

2.1.5 Secondary Distribution:

Electric power is transferred from Primary distribution i.e.11kV to secondary distribution sub station. This substation is located nearby consumers areas where the level of voltage reduced by step down 440V by Step down transformers.

These transformers called Distribution transformers, three phase four wire system is used ((3 Phase – 4 Wires)). So 400 Volts is available (Three Phase Supply System) between any two phases and 230 Volts (Single Phase Supply) between a neutral and phase (live) wires.

Residential load (i.e. Fans, Lights, and TV etc) will be connected between any one phase and neutral wires, while three phase load may be connected directly to the three phase lines.(RYB)

2.2 Various Systems of Power Transmission

It has already been pointed out that the transmission of electric power with 3-phase, 3-wire a.c. system is universally adopted. However, other systems can also be used for transmission under special circumstances.

The different possible systems of transmission are :

1. D.C. system

- (i) D.C. two-wire.
- (ii) D.C. two-wire with mid-point earthed.
- (iii) D.C. three-wire.

2. Single-phase A.C. system

- (i) Single-phase two-wire.
- (ii) Single-phase two-wire with mid-point earthed.
- (iii) Single-phase three-wire.

3. Two-phase A.C. system

- (i) Two-phase four-wire.
- (ii) Two-phase three wire.

4. Three-phase A.C. system

- (i) Three-phase three-wire.
- (ii) Three-phase four-wire.

From the above possible systems of power transmission, it is difficult to say the best system unless and until some method of comparison adopted. Now, the cost of conductor material is one of the most important charges in a system. Obviously, the best system for transmission of power is that for which the volume of conductor material required minimum. Therefore, the volume of conductor material required forms the basis of comparison between different systems. While comparing the amount of conductor material required in various systems, the proper comparison shall be on the basis of equal maximum stress on the dielectric. There are two cases:

(i) **When transmission with overhead system.** In the overhead system, the maximum disruptive stress exists between the conductor and the earth. Therefore, the comparison of the system In this case has to be made on the basis of maximum voltage between conductor and earth.

(ii) **When transmission with underground system.** In the underground system, the chief stress on the insulation is between conductors. Therefore, the comparison of the systems in this case should be made on the basis of maximum potential difference between conductors.

2.3 A.C. transmission.

Now-a-days, electrical energy is almost exclusively generated, transmitted and distributed in the form of a.c.

2.3.1 Advantages

- (i) The power can be generated at high voltages.
- (ii) The maintenance of a.c. sub-stations is easy and cheaper.
- (iii) The a.c. voltage can be stepped up or stepped down by transformers with ease and efficiency. This permits to transmit power at high voltages and distribute it at safe potentials.

2.3.2 Disadvantages

- (i) An a.c. line requires more copper than a D.C. line.
- (ii) The construction of a.c. transmission line is more complicated than a D.C. transmission line.
- (iii) Due to skin effect in the a.c. system, the effective resistance of the line is increased.
- (iv) An a.c. line has capacitance. Therefore, there is a continuous loss of power due to charging current even when the line is open.

2.3.2 Advantages of High Transmission Voltage

- With increase in the transmission voltage, the size of the conductors is reduced (Cross section of the conductors are reduced as required current is carrying capacity reduced).
- As the reduction in current carrying requirement, losses are reduced which leads better efficiency
- Due to low current, voltage drop will be less so voltage regulation improves

2.4 Economic Choice of Transmission Voltage

The cost of conductor material required can be reduced with reduction in volume of conduction material which is possible with increase in transmission voltage. The volume of conductor material is inversely proportional to transmission voltage as seen in previous posts. So it may be economical from the point of view of conductor material cost to go for maximum possible transmission voltage.

But with increase in transmission voltage, there will be a corresponding increase in cost of insulators, transformers, switchgear and other equipments. Thus for overall economy, there is optimum transmission voltage. The economical transmission voltage is one for which cost of conductor, insulators, transformers, switchgear and other equipments is minimum.

If the transmitted power to be transmitted, generation voltage and length of transmission are known quantities, then economical transmission voltage can be computed. Initially some standard transmission voltage is selected and costs of transformers, switchgear, conductors and other equipments are determined.

The transformers are present at generating and receiving ends of transmission line. The cost of transformer switchgear, lightning arrester, insulation and supports increases with increase in voltage. The total cost of transmission line for a given voltage is sum of costs of transformers, switchgear, lightning arrester, insulators, support and conductors. These costs are computed for different transmission voltages. From this data, a graph is drawn between total cost of transmission line versus transmission voltage which is shown in Fig. 2.2.

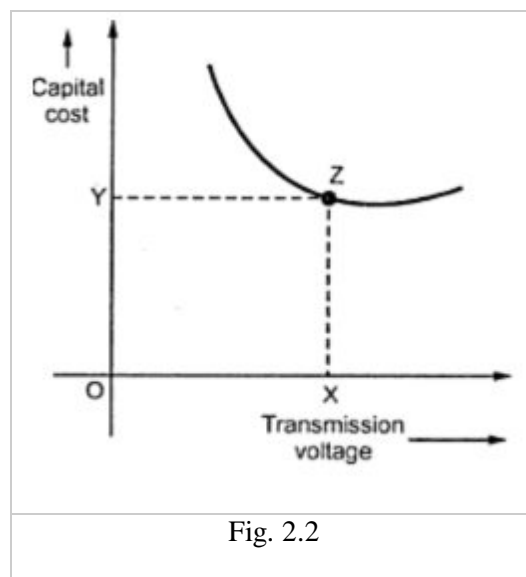

The economical voltage is one for which capital cost associated with line is minimum which is point Z from the Fig. 1. Thus optimum transmission voltage is represented by OX.

In practical this method is not having good accuracy as various cost associated in it.. Instead, an empirical formula is used for finding economical voltage. Thus the economic voltage between lines in 3 phase system is given by,

$$V = 5.5 \left[\frac{L}{1.6} + \frac{3P}{100} \right]^{0.5}$$

$$V = 5.5 \sqrt{0.62L + \frac{3P}{100}}$$

Here V = Line voltage in KV, L = Distance of transmission line in Km, P = Maximum power per phase to be delivered in a single circuit.

The economical transmission voltage depends on length (or distance) of transmission line and power to be transmitted. With increase in distance of transmission line, the cost of equipments and apparatus increases which results in higher transmission voltage. If the power to be transmitted is large then large units of generating and transforming systems are required which reduces the cost per Kw of terminal equipments.

2.5 Elements of a Transmission Line

For reasons associated with economy, transmission of electric power is done at high voltage by 3-phase, 3-wire overhead system. The principal elements of a high-voltage transmission system are:

(i) Conductors:

Usually three for a single-circuit line and six for a double-circuit line. The usual material is aluminum reinforced with steel.

(ii) Step-up and step-down transformers:

At the sending and receiving ends transformers are available. The use of transformers permits power to be transmitted at high efficiency with different voltage levels.

(iii) Line insulators:

It mechanically supports the line conductors and isolate them electrically from the ground.

(iv) Support:

Which are generally steel towers and provide support to the conductors.

(v) Protective devices:

Such as ground wires, lightning arrestors, circuit breakers, relays etc.They ensure the satisfactory service of the transmission line.

(vi) **Voltage regulating devices:**

Which maintain the voltage at the receiving end within permissible limits.

2.6 Economic Choice of Conductor Size - Kelvin's Law

As economy is one of the most important factors while designing any transmission line, the cost of required conductor material is a considerable part. Thus, it becomes vital to select a proper size of the conductor. The most economic design of a transmission line is for which the total annual cost is minimum. Total annual cost can be divided into two parts, viz. annual charges on capital outlay and running charges. Annual charges on capital outlay include depreciation, interest on the capital cost, maintenance cost etc.. The cost of energy lost during the operation is counted in running charges. Regarding this, there are two important points that must be noted -

- if the cross-sectional area of the conductor is decreased, the total capital cost of the conductor decreases but the line losses increase (resistance increases with the decrease in the conductor size, hence, I^2R loss increases)
- Whereas, if the cross-sectional area of the conductor is increased, the line losses decrease but the total capital cost increases.

Therefore, it is important to find the most economical size of the conductor. Kelvin's law helps in finding this.

www.binils.com

2.6.1 Kelvin's Law for Finding Economic Size Of A Conductor

Let, area of cross-section of conductor = a

Annual Interest and Depreciation on Capital Cost of the Conductor = C_1

Annual running charges = C_2

Now, annual interest and depreciation cost is directly proportional to the area of conductor.

$$\text{i.e., } C_1 = K_1 a$$

and, annual running charges are inversely proportional to the area of conductor.

$$C_2 = K_2/a$$

Where, K_1 and K_2 are constants.

Now, Total annual cost = $C = C_1 + C_2$

$$C = K_1 a + K_2/a$$

For C to be minimum, the differentiation of C w.r.t a must be zero. i.e. $dc/da = 0$.

Therefore,

$$\frac{dC}{da} = \frac{d}{da} \left[K_1 a + \frac{K_2}{a} \right] = 0$$

$$\therefore K_1 - \frac{K_2}{a^2} = 0$$

$$\therefore K_1 = \frac{K_2}{a^2}$$

$$\therefore K_1 a = \frac{K_2}{a}$$

$$\therefore C_1 = C_2$$

electricaleasy.com

"The Kelvin's law states that the most economical size of a conductor is that for which annual interest and depreciation on the capital cost of the conductor is equal to the annual cost of energy loss."

From the above derivation, the economical cross-sectional area of a conductor can be calculated as,

$$a = \sqrt{(K_2/K_1)}$$

Graphical Illustration Of Kelvin's Law

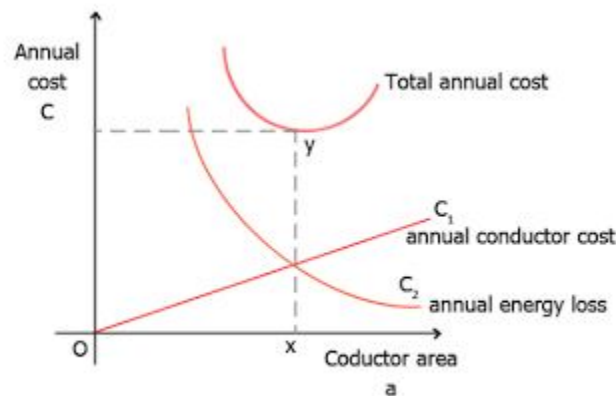

electricaleasy.com

Fig 2.3

As the annual cost of conductor is directly proportional to size of the conductor, it is shown by the straight line C_1 in the figure. Annual cost of energy loss is shown by the curve C_2 . The total annual cost curve is obtained by adding the curve C_1 and C_2 . The lowermost point on total annual cost curve gives the cost **economical size of the conductor** which corresponds to the intersection point of curve C_1 and C_2 . So, here, the most economical area of cross-section of the conductor is represented by ox

and the corresponding minimum cost is represented by xy .

2.6.2 Limitations of Kelvin's Law

Although Kelvin's law holds good theoretically, there is often considerable difficulty while applying it in practice.

The limitations of this law are:

1. It is quite difficult to estimate the energy loss in the line without actual load curves which are not available at the time of estimation.
2. Interest and depreciation on the capital cost cannot be determined accurately.
3. The conductor size determined using this law may not always be practicable one because it may not have sufficient mechanical strength.
4. This law does not take into account several factors like safe current carrying capacity, corona loss etc.
5. The economical size of a conductor may cause the voltage drop beyond the acceptable limits.

2.6.3 Modified Kelvin's Law

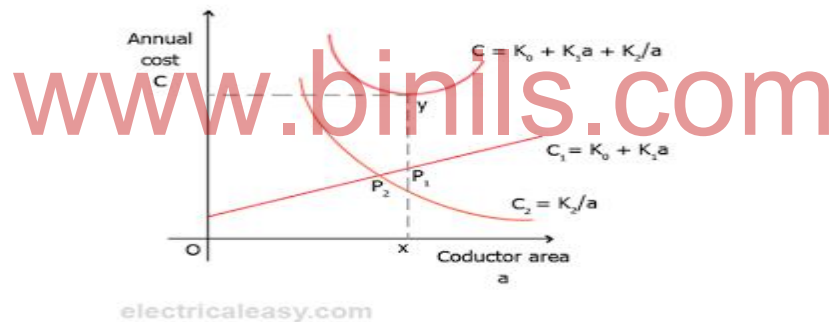

Fig2.4

The actual Kelvin's law does not count the cost of supporting structures, erection, insulators etc.. It only accounts for the capital cost of conductor and corresponding interest and depreciation. Also, for underground cables, the cost of insulation and laying is not considered in the actual Kelvin's law. To account for these costs and to get practically fair results, the initial investment needs to be divided into two parts, viz (i) one part which is independent of conductor size and (ii) other part which is directly proportional to the conductor size.

For an overhead line, insulator cost is almost constant and the cost of supporting structure and their erection is partly constant and partly proportional to the conductor size. So, according to the modified Kelvin's law, the annual charge on capital outlay is given as, $C_1 = K_0 + K_1a$. where, K_0 is an another constant. The differentiation of total cost C w.r.t. to the area of conductor (a) comes to be same as derived above under the heading Kelvin's law.

The modified statement of Kelvin's law suggests that the most economical conductor size is that for which the annual cost of energy loss is equal to the annual interest and depreciation for that part of capital cost which is proportional to the conductor size.

2.7 Over Head Line

Overhead lines have more advantages than underground lines. The underground cables are rarely used for power transmission due to two main reasons. Firstly, power is generally transmitted over long distances to load centres. Obviously; the installation costs for underground transmission will be very heavy. Secondly, electric power has to be transmitted at high voltages for economic reasons. It is very difficult to provide proper insulation to the cables to withstand such higher pressures. Therefore, as a rule, power transmission over long distances is carried out by using overhead lines.

An overhead line is subjected to uncertain weather conditions and other external interferences. This calls for the use of proper mechanical factors of safety in order to ensure the continuity of operation in the line. In general, the strength of the line should be such so as to provide against the worst probable weather conditions. In this we shall focus our attention on the various aspects of mechanical design of overhead lines.

2.8 Main components of Overhead lines:

An overhead line may be used to transmit or distribute electric power. The successful operation of an overhead line depends to a great extent upon the mechanical design of the line. While constructing an overhead line, it should be ensured that mechanical strength of the line is such so as to provide against the most probable weather conditions. In general, the main components of an overhead line are:

- (i) **Conductors** which carry electric power from the sending end station to the receiving end station.
- (ii) **Supports** which may be poles or towers and keep the conductors at a suitable level above the ground.
- (iii) **Insulators** which are attached to supports and insulate the conductors from the ground.
- (iv) **Cross arms** which provide support to the insulators.
- (v) **Miscellaneous items** such as phase plates, danger plates, lightning arrestors, anti-climbing wires etc.

Conductor materials used in Overhead lines:

The conductor is one of the important items as most of the capital outlay is invested for it. Therefore, proper choice of material and size of the conductor are of considerable importance. The conductor material used for transmission and distribution of electric power should have the following properties :

- (i) High electrical conductivity.

(ii) High tensile strength in order to withstand mechanical stresses.

(iii) low cost so that it can be used for long distances.

(iv) Low specific gravity so that weight per unit volume is small.

All above requirements are not found in a single material. Therefore, while selecting a conductor material for a particular case, a compromise is made between the cost and the required electrical and mechanical properties.

2.8.1 Commonly used conductor materials:

The most commonly used conductor materials for overhead lines are copper, aluminum, steel-cored aluminum, galvanized steel and cadmium copper. The choice of a particular material will depend upon the cost, the required electrical and mechanical properties and the local conditions.

All conductors used for overhead lines are preferably stranded in order to increase the flexibility. In stranded conductors, there is generally one central wire and round this, successive layers of wires containing 6, 12, 18, 24 wires. Thus, if there are n layers, the total number of individual wires is

$3n(n + 1) + 1$. In the manufacture of stranded conductors, the consecutive layers of wires are twisted or spiraled in opposite directions so that layers are bound together.

1. Copper:

Copper is an ideal material for overhead lines owing to its high electrical conductivity and greater tensile strength. It is always used in the hard drawn form as stranded conductor. Although hard drawing decreases the electrical conductivity slightly yet it increases the tensile strength considerably.

Copper has high current density i.e., the current carrying capacity of copper per unit of X-sectional area is quite large. This leads to two advantages. Firstly, smaller X-sectional area of conductor is required and secondly, the area offered by the conductor to wind loads is reduced. Moreover, this metal is quite homogeneous, durable and has high scrap value.

There is hardly any doubt that copper is an ideal material for transmission and distribution of electric power. However, due to its higher cost and non-availability, it is rarely used for these purposes. Now-a-days the trend is to use aluminum in place of copper.

2. Aluminum:

Aluminum is cheap and light as compared to copper but it has much smaller conductivity and tensile strength. The relative comparison of the two materials is briefed below:

(i) The conductivity of aluminum is 60% that of copper. The smaller conductivity of aluminum means that for any particular transmission efficiency, the cross-sectional area of conductor

must be larger in aluminum than in copper. For the same resistance, the diameter of aluminum conductor is about 1.26 times the diameter of copper conductor. The increased cross-section of aluminum exposes a greater surface to wind pressure and, therefore, supporting towers must be designed for greater transverse strength. This often requires the use of higher towers with consequence of greater sag.

(ii) The specific gravity of aluminium (2.71 gm/cc) is lower than that of copper (8.9 gm/cc). Therefore, an aluminium conductor has almost one-half the weight of equivalent copper conductor. For this reason, the supporting structures for aluminium need not be made so strong as that of copper conductor.

(iii) Aluminium conductor being light, is liable to greater swings and hence larger cross-arms are required.

(iv) Due to lower tensile strength and higher co-efficient of linear expansion of aluminium, the sag is greater in aluminium conductors. Considering the combined properties of cost, conductivity, tensile strength, weight etc., aluminium has an edge over copper. Therefore, it is being widely used as a conductor material. It is particularly profitable to use aluminium for heavy-current transmission where the conductor size is large and its cost forms a major proportion of the total cost of complete installation.

3. Steel cored aluminium:

Due to low tensile strength, aluminium conductors produce greater sag. This prohibits their use for larger spans and makes them unsuitable for long distance transmission. In order to increase the tensile strength, the aluminium conductor is reinforced with a core of galvanized steel wires. The composite conductor thus obtained is known as steel cored aluminium and is abbreviated as A.C.S.R. (aluminium conductor steel reinforced).

Steel-cored aluminium conductor consists of central core of galvanized steel wires surrounded by a number of aluminium strands. Usually, diameter of both steel and aluminium wires is the same. The cross-section of the two metals are generally in the ratio of 1 : 6 but can be modified to 1 : 4 in order to get more tensile strength for the conductor. Figure below shows steel cored aluminium conductor having one steel wire surrounded by six wires of aluminium. The result of this composite conductor is that steel core takes greater percentage of mechanical strength while aluminium strands carry the bulk of current. The steel cored aluminium conductors have the following advantages:

(i) The reinforcement with steel increases the tensile strength but at the same time keeps the composite conductor light. Therefore, steel cored aluminium conductors will produce smaller sag and hence longer spans can be used.

(ii) Due to smaller sag with steel cored aluminium conductors, towers of smaller heights can be used.

4. Galvanized steel:

Steel has very high tensile strength. Therefore, galvanized steel conductors can be used for extremely long spans or for short line sections exposed to abnormally high stresses due to climatic conditions. They have been found very suitable in rural areas where cheapness is the main consideration.

Due to poor conductivity and high resistance of steel, such conductors are not suitable for transmitting large power over a long distance. However, they can be used to advantage for transmitting a small power over a small distance where the size of the copper conductor desirable from economic considerations would be too small and thus unsuitable for use because of poor mechanical strength.

5. Cadmium copper:

The conductor material now being employed in certain cases is copper alloyed with cadmium. An addition of 1% or 2% cadmium to copper increases the tensile strength by about 50% and the conductivity is only reduced by 15% below that of pure copper. Therefore, cadmium copper conductor can be useful for exceptionally long spans. However, due to high cost of cadmium, such conductors will be economical only for lines of small cross-section i.e., where the cost of conductor material is comparatively small compared with the cost of supports.

2.9 Line Supports

The supporting structures for overhead line conductors are various types of poles and towers called line supports

2.9.1 Properties of Line Supports

In general, the line supports should have the following properties :

- (i) High mechanical strength to withstand the weight of conductors and wind loads etc.
- (ii) Light in weight without the loss of mechanical strength.
- (iii) Cheap in cost and economical to maintain.
- (iv) Longer life.
- (v) Easy accessibility of conductors for maintenance.

2.9.2 Types of supports

The line supports used for transmission and distribution of electric power are of various types including *wooden poles, steel poles, R.C.C. poles* and *lattice steel towers*. The choice of supporting structure for a particular case depends upon the line span, X-sectional area, line voltage, cost and local conditions.

1. Wooden poles.

These are made of seasoned wood (sal or chir) and are suitable for lines of moderate cross-sectional area and of relatively shorter spans, say up to 50 meters. Such supports are cheap, easily available, provide insulating properties and, therefore, are widely used for distribution purposes in rural areas as an economical proposition. The wooden poles generally tend to rot below the ground level, causing foundation failure. In order to prevent this, the portion of the pole below the ground level is impregnated with preservative compounds like *creosote oil*. Double pole structures of the 'A' or 'H' type are often used to obtain a higher transverse strength than could be economically provided by means of single poles.

The main objections to wooden supports are:

- (i) Tendency to rot below the ground level
- (ii) Comparatively smaller life (20-25 years)
- (iii) Cannot be used for voltages higher than 20 kV
- (iv) Less mechanical strength and
- (v) Require periodical inspection.

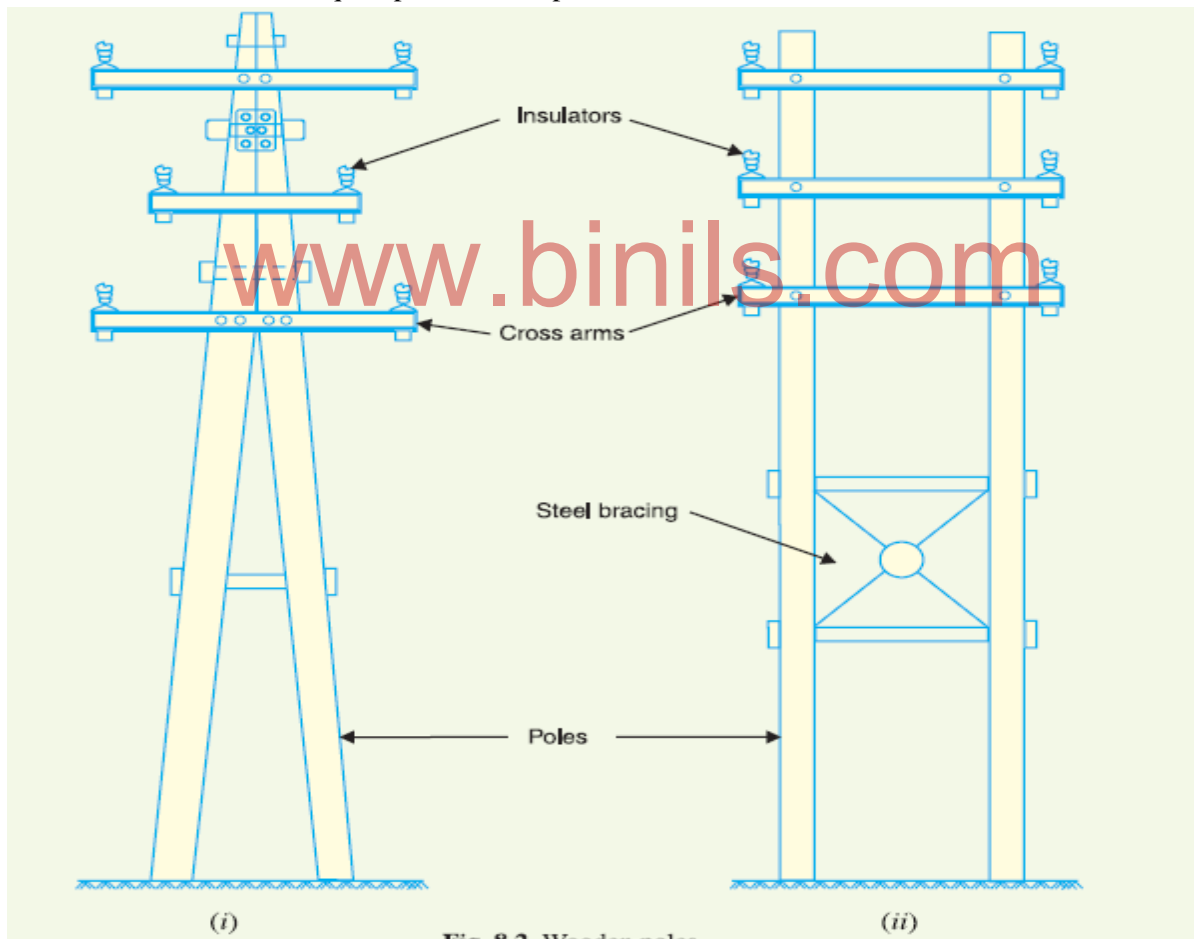

Fig 2.5

1. Steel poles.

The steel poles are often used as a substitute for wooden poles. They possess greater mechanical strength, longer life and permit longer spans to be used. Such poles are generally used for distribution purposes in the cities. This type of supports needs to be galvanized or painted in order to prolong its life. The steel poles are of three types *viz.*,

- (i) Rail poles
- (ii) Tubular poles and
- (iii) Rolled steel joints.

2. RCC poles.

The reinforced concrete poles have become very popular as line supports in recent years. They have greater mechanical strength, longer life and permit longer spans than steel poles. Moreover, they give good outlook, require little maintenance and have good insulating properties. Fig. 8.3 shows R.C.C. poles for single and double circuit. The holes in the poles facilitate the climbing of poles and at the same time reduce the weight of line supports. The main difficulty with the use of these poles is the high cost of transport owing to their heavy weight. Therefore, such poles are often manufactured at the site in order to avoid heavy cost of transportation.

3. Steel towers.

In practice, wooden, steel and reinforced concrete poles are used for distribution purposes at low voltages, say upto 11 kV. However, for long distance transmission at higher voltage, steel towers are invariably employed. Steel towers have greater mechanical strength, longer

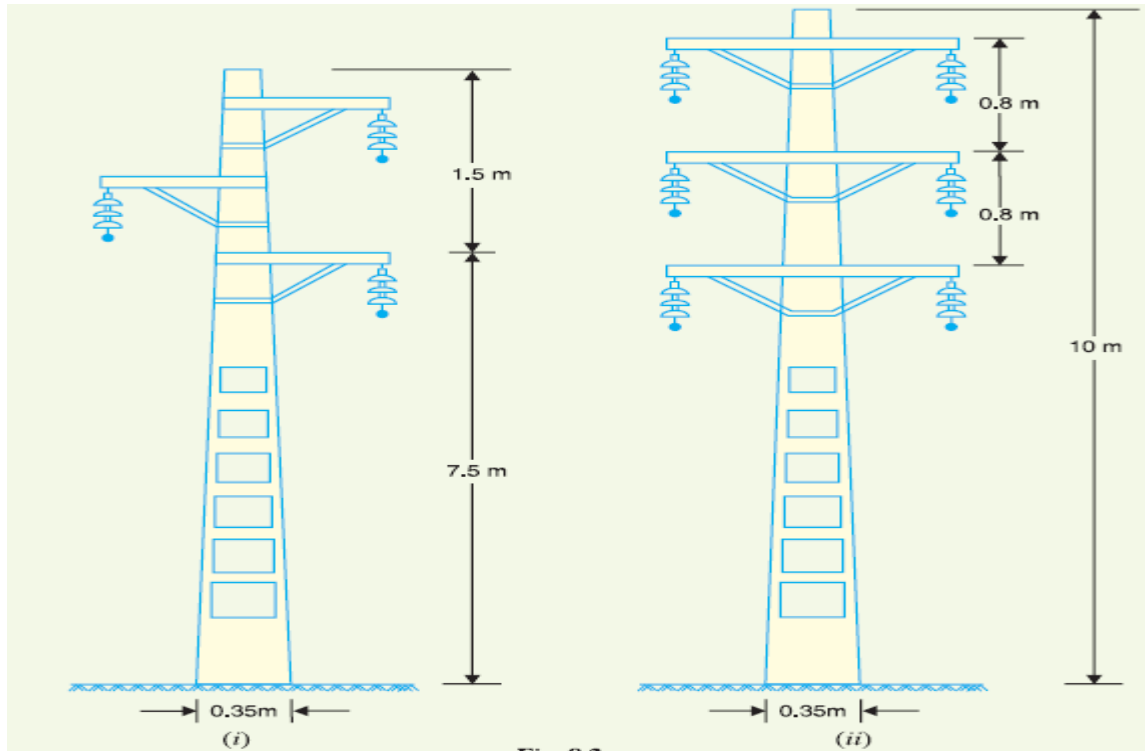

Fig 2.6

life, can withstand most severe climatic conditions and permit the use of longer spans. The risk of interrupted service due to broken or punctured insulation is considerably reduced owing to longer spans. Tower footings are usually grounded by driving rods into the earth. This minimises the lightning troubles as each tower acts as a lightning conductor.

2.10 Spacing between conductors.

If the spacing between the conductors is made very large as compared to their diameters, there may not be any corona effect. It is because larger distance between conductors reduces the electro-static stresses at the conductor surface, thus avoiding corona formation.

2.11 Sag in Overhead Lines

While erecting an overhead line, it is very important that conductors are under safe tension. If the Conductors are too much stretched between supports in a bid to save conductor material, the stress in the conductor may reach unsafe value and in certain cases the conductor may break due to excessive tension. In order to permit safe tension in the conductors, they are not fully stretched but are allowed to have a dip or sag.

The difference in level between points of supports and the lowest point on the conductor is called sag.

Fig 2.7 Shows a conductor suspended between two equilevel supports A and B . The conductor is not fully stretched but is allowed to have a dip. The lowest point on the conductor is O and the sag is S . The following points may be noted :

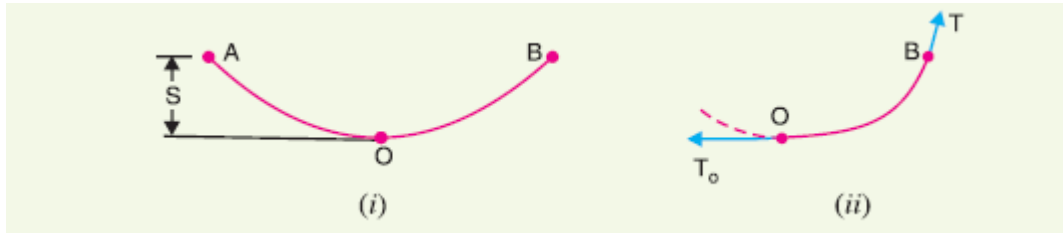

Fig 2.7

(i) When the conductor is suspended between two supports at the same level, it takes the shape of catenaries. However, if the sag is very small compared with the span, then sag-span curve is like a parabola.

(ii) The tension at any point on the conductor acts tangentially. Thus tension TO at the lowest point O acts horizontally as shown in Fig. 2.7(ii).

(iii) The horizontal component of tension is constant throughout the length of the wire.

(iv) The tension at supports is approximately equal to the horizontal tension acting at any point on the wire. Thus if T is the tension at the support B , then $T = TO$.

2.11.1 Conductor sag and tension.

This is an important consideration in the mechanical design of overhead lines. The conductor sag should be kept to a minimum in order to reduce the conductor material required and to avoid extra pole height for sufficient clearance above ground level. It is also desirable that tension in the conductor should be low to avoid the mechanical failure of conductor and to permit the use of less strong supports. However, low conductor tension and minimum sag are not possible. It is because low sag means a tight wire and high tension, whereas a low tension means a loose wire and increased sag. Therefore, in actual practice, a compromise is made between the two.

2.12 Calculation of Sag

In an overhead line, the sag should be so adjusted that tension in the conductors is within safe limits. The tension is governed by conductor weight, effects of wind, ice loading and temperature variations. It is a standard practice to keep conductor tension less than 50% of its ultimate

tensile strength *i.e.*, minimum factor of safety in respect of conductor tension should be 2. We shall now calculate sag and tension of a conductor when

- (i) Supports are at equal levels and
- (ii) Supports are at unequal levels.

Supports are at equal levels

Consider a conductor AOB suspended freely between level supports A and B at the same level. The lowest point of the conductor is O. Let the shape of the conductor be a parabola.

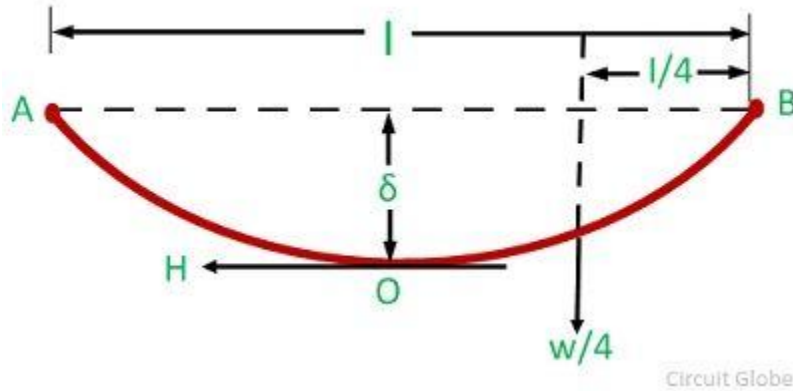

Fig 2.8

Let,

l – Span length

w - weight per unit length of the conductor

δ – conductor sag

H – tension in the conductor at the point of maximum deflection O

T_B – tension in the conductor at the point of support B.

Consider OB is the equilibrium tension of the conductor and force acting on it are the horizontal tension H at O. The weight ($w \cdot OB$) of the conductor OB acting vertically downwards through the center of gravity at a distance $l/4$ from B, and the tension T_B at the support B.

$$H\delta = (w \cdot OB)l/4$$

Since OB is approximately equal to the $l/2$

Take moments about B

$$H \cdot \delta = w \cdot \frac{l}{2} \times \frac{l}{4}$$

$$\delta = \frac{wl^2}{8H}$$

Above equation shows that the sag in a freely suspended conductor is directly proportional to the weight per unit length of the conductor, and the square of the span length and inversely proportional to the horizontal tension H.

2.12 Calculation of Sag and Tension at an unequal level supports

In hilly areas or sloping grounds, the supports are not usual at the same level. For the calculation of sag and tension at unequal supports level consider a conductor AOB. The portion of OA and OB may be treated as catenaries of half span x and l-x respectively shown in the figure below.

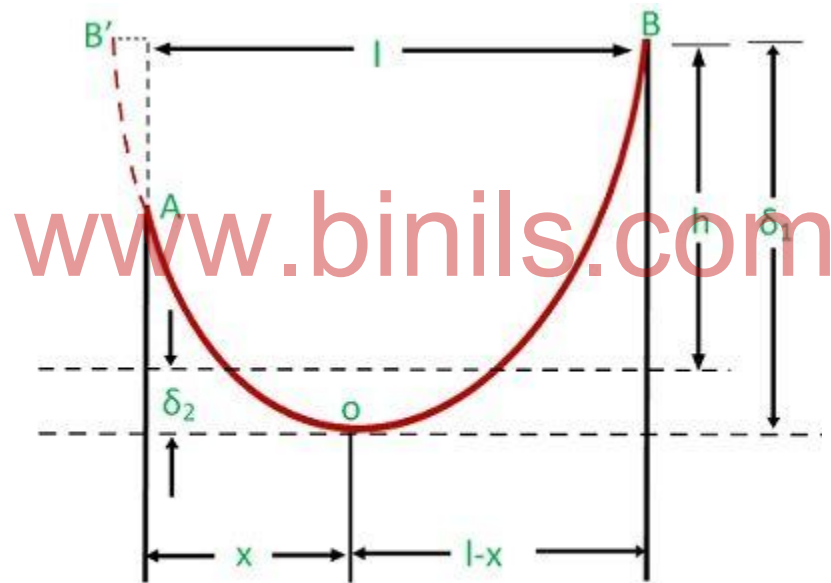

Supports at unequal levels.

Circuit Globe

Fig 2.9

Let,

h – Difference span length between A and B

l – horizontal span length between A and B

x – the horizontal distance of A from the lowest point O.

l – x – a horizontal distance of B from the lowest point O.

The sag at OA and OB is expressed by the equations

$$\delta_1 = \frac{H}{w} \left[\cosh \frac{w(l-x)}{H} - 1 \right] \dots \dots \dots \text{equ(1)}$$

$$\delta_2 = \frac{H}{w} \left[\cosh \left(\frac{wx}{H} \right) - 1 \right] \dots \dots \dots \text{equ(2)}$$

The tension A and B are given by

$$T_A = H \cosh \frac{wx}{H} \dots \dots \dots \text{equ(3)}$$

$$T_B = H \cosh \frac{w(l-x)}{H} \dots \dots \dots \text{equ(4)}$$

The maximum tension will occur at B since (l-x) is greater than x as seen in the figure above.

Vertical reaction at the higher support – w.(l-x)

Vertical reaction at lower support – w.x

For calculation, it is assumed that the AOB is the parabola.

$$\delta_1 = \frac{w[2(l-x)]^2}{8T} = \frac{w(l-x)^2}{2T} \dots \dots \dots \text{equ(5)}$$

$$\delta_2 = \frac{w(2x)^2}{8T} = \frac{wx^2}{2T} \dots \dots \dots \text{equ(6)}$$

But,

$$h = \delta_1 - \delta_2 = \frac{w(l-x)^2}{2T} - \frac{wx^2}{2T} \quad x = \frac{l}{2} - \frac{Th}{wl} \dots \dots \dots \text{equ(7)}$$

$$h = \frac{wl}{2T} (l - 2x)$$

$$\frac{2Th}{wl} = l - 2x \quad l - x = \frac{l}{2} + \frac{Th}{wl} \dots \dots \dots \text{equ(8)}$$

The value of x obtained above may be substituted in equation (5) to calculate sag at OA . Equation (8) shows that the lowest point lies outside the span AB. Hence, the conductor in the span under consideration exert an upward force, and the conductor tends to swing clear of the lower support.

Problems

Example 1

A 132 kV transmission line has the following data:

Wt. of conductor = 680 kg/km; Length of span = 260 m

Ultimate strength = 3100 kg; Safety factor = 2

Calculate the height above ground at which the conductor should be supported. Ground clearance required is 10 meters.

Solution.

Wt. of conductor/metre run, $w = 680/1000 = 0.68 \text{ kg}$

Working tension, $T = \frac{\text{Ultimate strength}}{\text{Safety factor}} = \frac{3100}{2} = 1550 \text{ kg}$

Span length, $l = 260 \text{ m}$

$\therefore \text{Sag} = \frac{wl^2}{8T} = \frac{0.68 \times (260)^2}{8 \times 1550} = 3.7 \text{ m}$

\therefore Conductor should be supported at a height of $10 + 3.7 = 13.7 \text{ m}$

Example 2

www.binils.com

A transmission line has a span of 150 m between level supports. The conductor has a cross-sectional area of 2 cm². The tension in the conductor is 2000 kg. If the specific gravity of the conductor material is 9.9 gm/cm³ and wind pressure is 1.5 kg/m length, calculate the sag. What is the vertical sag?

Solution.

Span length, $l = 150$ m; Working tension, $T = 2000$ kg

Wind force/m length of conductor, $w_w = 1.5$ kg

Wt. of conductor/m length, $w = \text{Sp. Gravity} \times \text{Volume of 1 m conductor}$
 $= 9.9 \times 2 \times 100 = 1980 \text{ gm} = 1.98 \text{ kg}$

Total weight of 1 m length of conductor is

$$w_t = \sqrt{w^2 + w_w^2} = \sqrt{(1.98)^2 + (1.5)^2} = 2.48 \text{ kg}$$

$$\therefore \text{Sag, } S = \frac{w_t l^2}{8T} = \frac{2.48 \times (150)^2}{8 \times 2000} = 3.48 \text{ m}$$

This is the value of slant sag in a direction making an angle θ with the vertical. Referring to Fig. 8.27, the value of θ is given by :

$$\tan \theta = w_w/w = 1.5/1.98 = 0.76$$

$$\therefore \theta = \tan^{-1} 0.76 = 37.23^\circ$$

$$\therefore \text{Vertical sag} = S \cos \theta$$
$$= 3.48 \times \cos 37.23^\circ = 2.77 \text{ m}$$

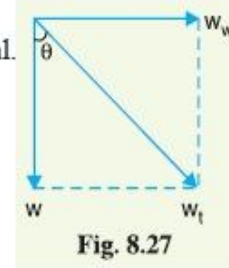

Example 3

A transmission line has a span of 200 metres between level supports. The conductor has a cross-sectional area of 1.29 cm², weighs 1170 kg/km and has a breaking stress of 4218 kg/cm². Calculate the sag for a safety factor of 5, allowing a wind pressure of 122 kg per square meter of projected area. What is the vertical sag?

Solution.

Span length, $l = 200$ m

Wt. of conductor/m length, $w = 1170/1000 = 1.17$ kg

Working tension, $*T = 4218 \times 1.29/5 = 1088$ kg

Diameter of conductor, $d = \sqrt{\frac{4 \times \text{area}}{\pi}} = \sqrt{\frac{4 \times 1.29}{\pi}} = 1.28$ cm

Wind force/m length, $w_w = \text{Pressure} \times \text{projected area in m}^2$
 $= (122) \times (1.28 \times 10^{-2} \times 1) = 1.56$ kg

Total weight of conductor per metre length is

$$w_t = \sqrt{w^2 + w_w^2} = \sqrt{(1.17)^2 + (1.56)^2} = 1.95 \text{ kg}$$

$$\therefore \text{Slant sag, } S = \frac{w_t l^2}{8T} = \frac{1.95 \times (200)^2}{8 \times 1088} = 8.96 \text{ m}$$

The slant sag makes an angle θ with the vertical where value of θ is given by :

$$\theta = \tan^{-1} (w_w/w) = \tan^{-1} (1.56/1.17) = 53.13^\circ$$

$$\therefore \text{Vertical sag} = S \cos \theta = 8.96 \times \cos 53.13^\circ = 5.37 \text{ m}$$

Example 4

A transmission line has a span of 214 meters between level supports. The conductors have a cross-sectional area of 3.225 cm². Calculate the factor of safety under the following conditions:

Vertical sag = 2.35 m;

Wind pressure = 1.5 kg/m run

Breaking stress = 2540 kg/cm²;

Wt. of conductor = 1.125 kg/m run

Solution.

Here, $l = 214 \text{ m}$; $w = 1.125 \text{ kg}$; $w_w = 1.5 \text{ kg}$

Total weight of one metre length of conductor is

$$w_t = \sqrt{w^2 + w_w^2} = \sqrt{(1.125)^2 + (1.5)^2} = 1.875 \text{ kg}$$

If f is the factor of safety, then,

$$\text{Working tension, } T = \frac{\text{Breaking stress} \times \text{conductor area}}{\text{safety factor}} = \frac{2540 \times 3.225}{f} = 8191/f \text{ kg}$$

$$\text{Slant Sag, } S = \frac{\text{Vertical sag}}{\cos \theta} = \frac{2.35 \times 1.875}{1.125} = 3.92 \text{ m}$$

$$\text{Now } S = \frac{w_t l^2}{8T}$$

$$\text{or } T = \frac{w_t l^2}{8S}$$

$$\therefore \frac{8191}{f} = \frac{1.875 \times (214)^2}{8 \times 3.92}$$

$$\text{or Safety factor, } f = \frac{8191 \times 8 \times 3.92}{1.875 \times (214)^2} = 3$$

www.binils.com

Example 5

The towers of height 30 m and 90 m respectively support a transmission line conductor at water crossing. The horizontal distance between the towers is 500 m. If the tension in the conductor is 1600 kg, find the minimum clearance of the conductor and water and clearance mid-way between the supports. Weight of conductor is 1.5 kg/m. Bases of the towers can be considered to be at water level.

Solution. Fig. 8.28 shows the conductor suspended between two supports *A* and *B* at different levels with *O* as the lowest point on the conductor.

Here, $l = 500$ m ; $w = 1.5$ kg ; $T = 1600$ kg.

Difference in levels between supports, $h = 90 - 30 = 60$ m. Let the lowest point *O* of the conductor be at a distance x_1 from the support at lower level (*i.e.*, support *A*) and at a distance x_2 from the support at higher level (*i.e.*, support *B*).

Obviously, $x_1 + x_2 = 500$ m ...(i)

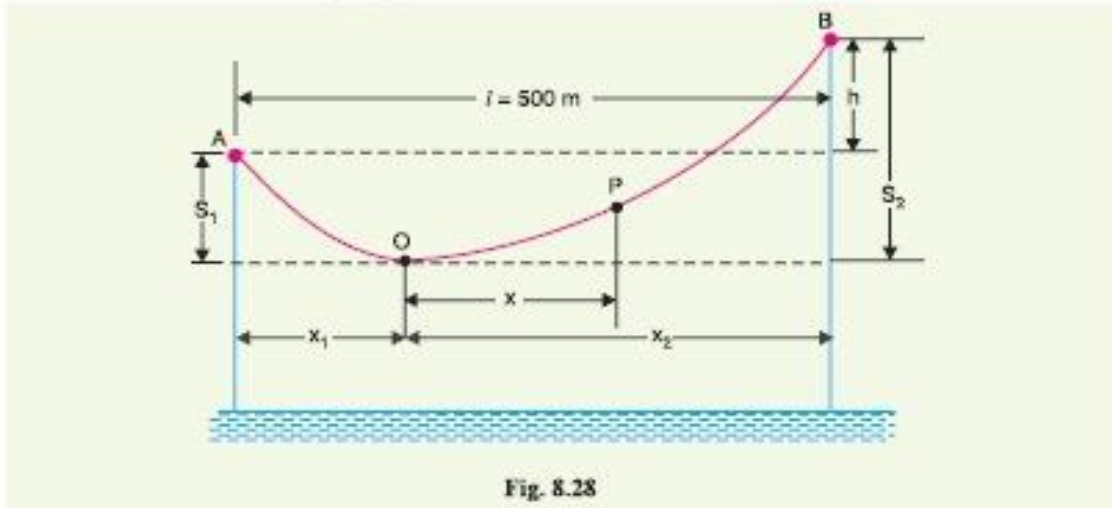

Fig. 8.28

Now $\text{Sag } S_1 = \frac{w x_1^2}{2T}$ and $\text{Sag } S_2 = \frac{w x_2^2}{2T}$

$\therefore h = S_2 - S_1 = \frac{w x_2^2}{2T} - \frac{w x_1^2}{2T}$

or $60 = \frac{w}{2T} (x_2 + x_1)(x_2 - x_1)$

$\therefore x_2 - x_1 = \frac{60 \times 2 \times 1600}{1.5 \times 500} = 256$ m ...(ii)

Solving exps. (i) and (ii), we get, $x_1 = 122$ m; $x_2 = 378$ m

Now, $S_1 = \frac{w x_1^2}{2T} = \frac{1.5 \times (122)^2}{2 \times 1600} = 7$ m

Clearance of the lowest point *O* from water level
 $= 30 - 7 = 23$ m

Let the mid-point *P* be at a distance x from the lowest point *O*.

Clearly, $x = 250 - x_1 = 250 - 122 = 128$ m

Sag at mid-point *P*, $S_{mid} = \frac{w x^2}{2T} = \frac{1.5 \times (128)^2}{2 \times 1600} = 7.68$ m

Clearance of mid-point *P* from water level $= 23 + 7.68 = 30.68$ m

Example 6

An overhead transmission line conductor having a parabolic configuration weighs 1.925 kg per meter of length. The area of X-section of the conductor is 2.2 cm² and the ultimate strength is 8000 kg/cm². The supports are 600 m apart having 15 m difference of levels. Calculate the sag from the taller of the two Supports which must be allowed so that the factor of safety shall be 5. Assume that ice load is 1 kg per metre run and there is no wind pressure.

Solution.

shows the conductor suspended between two supports at A and B at different levels with O as the lowest point on the conductor.

$$\text{Here, } l = 600 \text{ m ; } w_i = 1 \text{ kg ; } h = 15 \text{ m}$$

$$w = 1.925 \text{ kg ; } T = 8000 \times 2.2/5 = 3520 \text{ kg}$$

Total weight of 1 m length of conductor is

$$wt = w + w_i = 1.925 + 1 = 2.925 \text{ kg}$$

Let the lowest point O of the conductor be at a distance x_1 from the support at lower level (i.e., A) and at a distance x_2 from the support at higher level (i.e., B).

$$\text{Clearly, } x_1 + x_2 = 600 \text{ m -----(i)}$$

Now,
$$h = S_2 - S_1 = \frac{w_l x_2^2}{2T} - \frac{w_l x_1^2}{2T}$$

or,
$$15 = \frac{w_l}{2T} (x_2 + x_1)(x_2 - x_1)$$

∴
$$x_2 - x_1 = \frac{2 \times 15 \times 3520}{2.925 \times 600} = 60 \text{ m} \quad \dots(ii)$$

Solving eqns. (i) and (ii), we have, $x_1 = 270 \text{ m}$ and $x_2 = 330 \text{ m}$

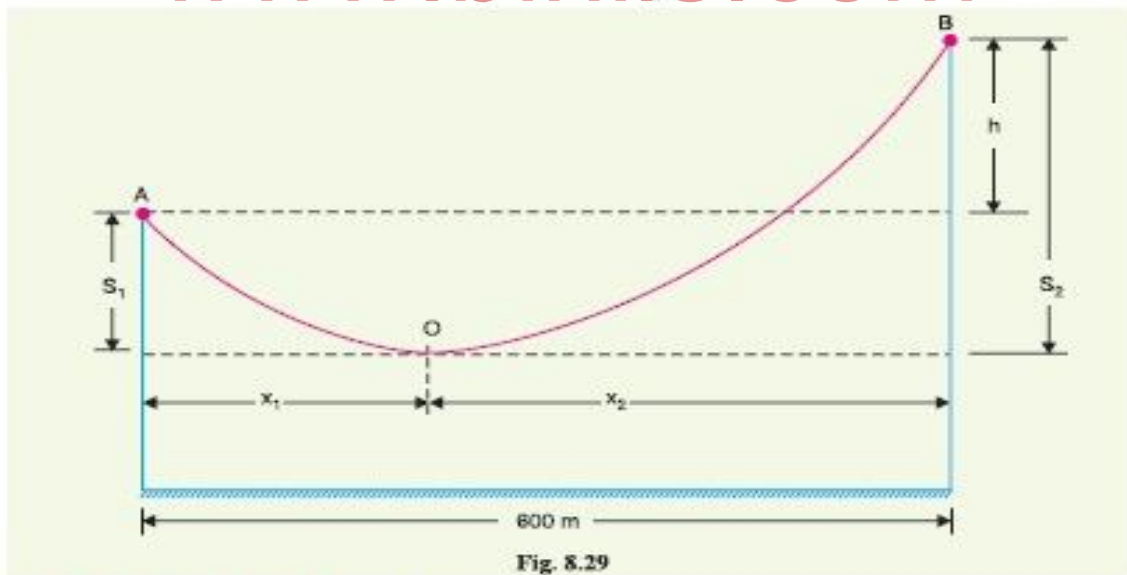

Sag from the taller of the two towers is

$$S_2 = \frac{w_l x_2^2}{2T} = \frac{2.925 \times (330)^2}{2 \times 3520} = 45.24 \text{ m}$$

2.13 Effect of Ice and Wind on Sag

- The weight per unit length of the conductor is changed when wind blows at a certain force on the conductor and ice accumulate around the conductor.
- Wind force acts on the conductor to change the conductor self weight per unit length horizontally in the direction of the air flow.
- Ice loading acts on the conductor to change the conductor self weight per unit length vertically downward.
- Considering wind force and ice loading both at a time, the conductor will have a resultant weight per unit length.
- The resultant weight will create an angle with the ice loading down ward direction.

Let us assume,

w is the weight of the conductor per unit length.

w_i is the weight of ice per unit length

$w_i = \text{density of ice} \times \text{volume of ice per unit length}$

$$\begin{aligned} &= \text{density of ice} \times \frac{\pi}{4} [(d + 2t)^2 - d^2] \times 1 \\ &= \text{density of ice} \times \pi t(d + t) \end{aligned}$$

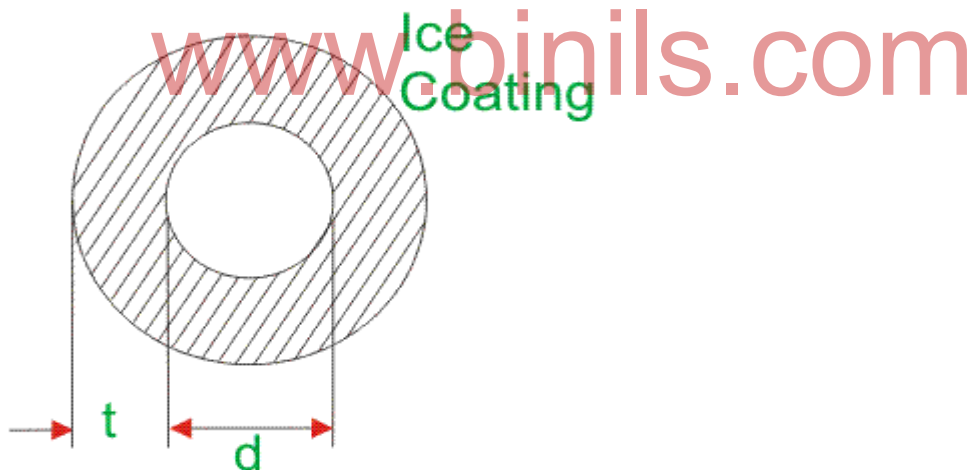

w_w is the force of wind per unit length $w_w = \text{wind pressure per unit area} \times \text{projected area per unit length}$

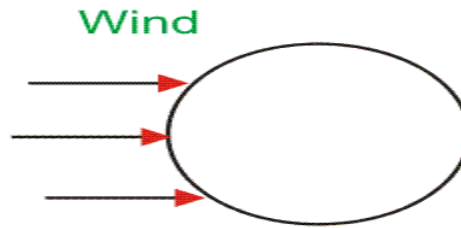

$$= \text{wind pressure} \times [(d + 2t) \times 1]$$

So, the total weight of the conductor per unit length is

$$w_t = \sqrt{(w + w_i)^2 + (w_w)^2}$$

$$\text{And } \tan \theta = \frac{w_w}{w + w_i}$$

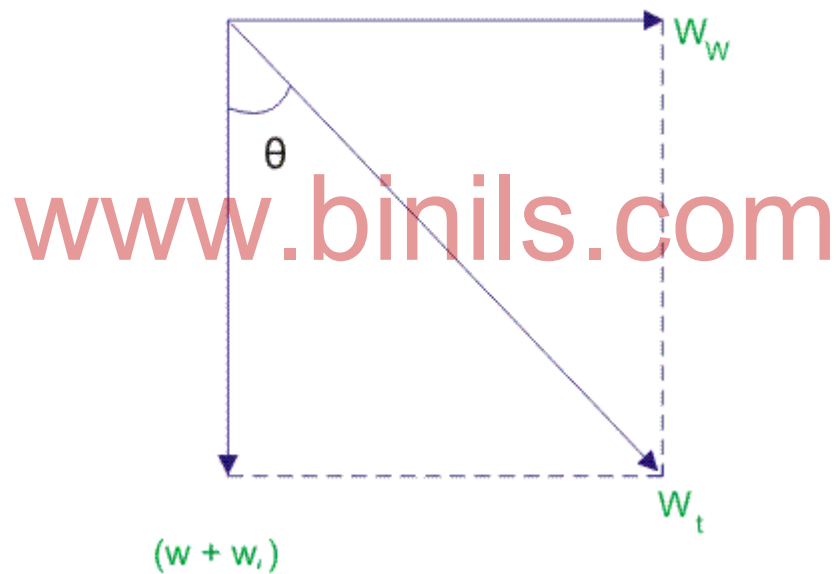

The sag in the conductor is given by

$$S = \frac{w_t L^2}{2T}$$

So the vertical sag

$$S_v = S \cos \theta$$

2.14 Constants of a Transmission Line

A transmission line has resistance, inductance and capacitance uniformly distributed along the whole length of the line. Before we pass on to the methods of finding these constants for a transmission line, it is profitable to understand them thoroughly.

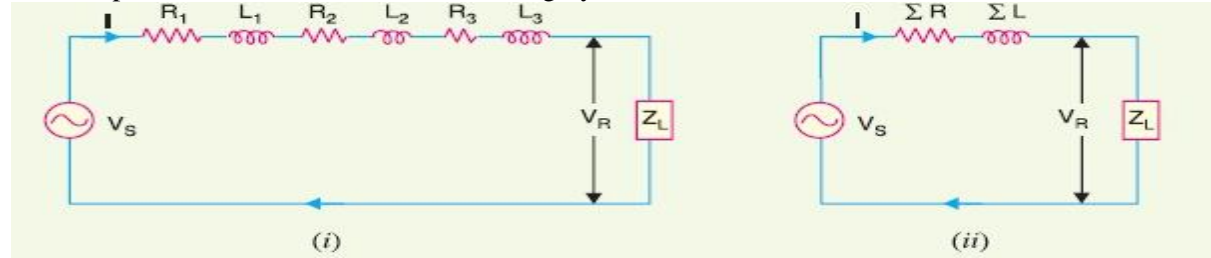

(i) Resistance.

It is the opposition of line conductors to current flow. The resistance is distributed uniformly along the whole length of the line as shown in Fig. 9.1 (i). However, the performance of a transmission line can be analyzed conveniently if distributed resistance is considered as lumped as shown in

(ii) Inductance.

When an alternating current flows through a conductor, a changing flux is set up which links the conductor. Due to these flux linkages, the conductor possesses inductance. Mathematically, inductance is defined as the flux linkages per ampere i.e.,

Inductance, $L = \psi / I$ henry

where ψ = flux linkages in weber-turns

I = current in amperes

The inductance is also uniformly distributed along the length of the line as shown in Fig. (i). Again for the convenience of analysis, it can be taken to be lumped as shown in Fig. (ii).

(iii) Capacitance.

We know that any two conductors separated by an insulating material constitute a capacitor. As any two conductors of an overhead transmission line are separated by air which acts as an insulation, therefore, capacitance exists between any two overhead line conductors. The capacitance between the conductors is the charge per unit potential difference i.e.,

Capacitance, $C = q/v$ farad

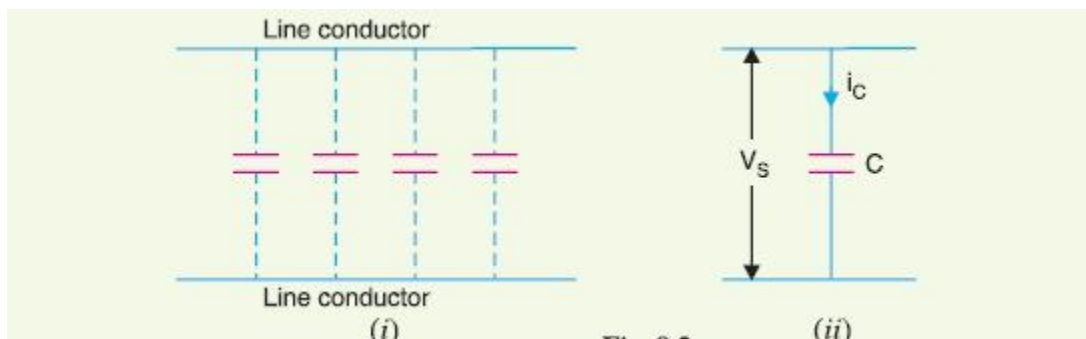

where q = charge on the line in coulomb
 v = p.d. between the conductors in volts

The capacitance is uniformly distributed along the whole length of the line and may be regarded as a uniform series of capacitors connected between the conductors as shown in Fig. 9.2(i). When an alternating voltage is impressed on a transmission line, the charge on the conductors at any point increases and decreases with the increase and decrease of the instantaneous value of the voltage between conductors at that point. The result is that a current (known as charging current) flows between the conductors [See Fig. 9.2(ii)]. This charging current flows in the line even when it is open-circuited i.e., supplying no load. It affects the voltage drop along the line as well as the efficiency and power factor of the line.

2.15 Transposition of Conductors

Transposition of Conductors refers to the exchanging of position of conductors of a three phase system along the transmission distance in such a manner that each conductor occupies the original position of every other conductor over an equal distance.



When conductors are not transposed at regular intervals, the inductance and capacitance of the conductors will not be equal.

When conductors such as telephone lines are run in parallel to transmission lines, there is a possibility of high voltages induced in the telephone lines. This can result in acoustic shock or noise. Transposition greatly reduces this undesired phenomenon.

In practice, however, conductors are not transposed in the transmission lines. The transposition is done in the switching stations and the substations.

2.16 Skin Effect

When a conductor is carrying steady direct current (d.c.), this current is uniformly distributed over the whole cross-section of the conductor. However, an alternating current flowing through the conductor does not distribute uniformly, rather it has the tendency to concentrate near the surface of the conductor as. This is known as skin effect.

The tendency of alternating current to concentrate near the surface of a conductor is known as **skin effect**.

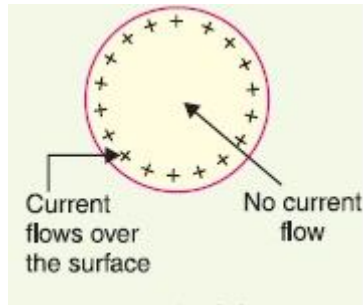

Due to skin effect, the effective area of cross-section of the conductor through which current flows is reduced. Consequently, the resistance of the conductor is slightly increased when carrying an alternating current. The cause of skin effect can be easily explained. A solid conductor may be thought to be consisting of a large number of strands, each carrying a small part of the current. The inductance of each strand will vary according to its position. Thus, the strands near the centre are surrounded by a greater magnetic flux and hence have larger inductance than that near the surface. The high reactance of inner strands causes the alternating current to flow near the surface of conductor. This crowding of current near the conductor surface is the skin effect. The skin effect depends upon the following factors :

- (i) Nature of material
- (ii) Diameter of wire – increases with the diameter of wire.
- (iii) Frequency – increases with the increase in frequency.
- (iv) Shape of wire – less for stranded conductor than the solid conductor.

It may be noted that skin effect is negligible when the supply frequency is low (< 50 Hz) and Conductor diameter is small (< 1 cm).

2.17 Ferranti Effect

A long transmission line has a large capacitance. If such a line is open-circuited or connected to the very light load at the receiving end, the magnitude of the voltage at the receiving end becomes higher than the voltage at the sending end. This phenomenon is called Ferranti effect.

2.18 corona loss

The phenomenon of corona is accompanied by a hissing sound, production of ozone, power loss and radio interference. The higher the voltage is raised, the larger and higher the luminous envelope becomes, and greater are the sound, the power loss and the radio noise. If the applied voltage is increased to breakdown value, a flash-over will occur between the conductors due to the breakdown of air insulation.

The phenomenon of violet glow, hissing noise and production of ozone gas in an overhead transmission line is known as corona.

2.18.1 Corona formation

Some ionisation is always present in air due to cosmic rays, ultraviolet radiations and radioactivity. Therefore, under normal conditions, the air around the conductors contains some ionised

particles (i.e., free electrons and +ve ions) and neutral molecules. When p.d. is applied between the conductors, potential gradient is set up in the air which will have maximum value at the conductor surfaces. Under the influence of potential gradient, the existing free electrons acquire greater velocities. The greater the applied voltage, the greater the potential gradient and more is the velocity of free electrons.

When the potential gradient at the conductor surface reaches about 30 kV per cm (max. value), the velocity acquired by the free electrons is sufficient to strike a neutral molecule with enough force to dislodge one or more electrons from it. This produces another ion and one or more free electrons, which in turn are accelerated until they collide with other neutral molecules, thus producing other ions. Thus, the process of ionisation is cumulative. The result of this ionisation is that either corona is formed or spark takes place between the conductors.

2.18.2 Factors Affecting Corona

The phenomenon of corona is affected by the physical state of the atmosphere as well as by the conditions of the line. The following are the factors upon which corona depends :

(i) Atmosphere.

As corona is formed due to ionisation of air surrounding the conductors, therefore, it is affected by the physical state of atmosphere. In the stormy weather, the number of ions is more than normal and as such corona occurs at much less voltage as compared with fair weather.

(ii) Conductor size.

The corona effect depends upon the shape and conditions of the conductors. The rough and irregular surface will give rise to more corona because unevenness of the surface decreases the value of breakdown voltage. Thus a stranded conductor has irregular surface and hence gives rise to more corona than a solid conductor.

(iii) Spacing between conductors.

If the spacing between the conductors is made very large as compared to their diameters, there may not be any corona effect. It is because larger distance between conductors reduces the electro-static stresses at the conductor surface, thus avoiding corona formation.

(iv) Line voltage.

The line voltage greatly affects corona. If it is low, there is no change in the condition of air surrounding the conductors and hence no corona is formed. However, if the line voltage has such a value that electrostatic stresses developed at the conductor surface make the air around the conductor conducting, then corona is formed.

2.18.3 Advantages and Disadvantages of Corona

Corona has many advantages and disadvantages. In the correct design of a high voltage overhead line, a balance should be struck between the advantages and disadvantages.

Advantages

- (i) Due to corona formation, the air surrounding the conductor becomes conducting and hence virtual diameter of the conductor is increased. The increased diameter reduces the electrostatic stresses between the conductors.
- (ii) Corona reduces the effects of transients produced by surges.

Disadvantages

- (i) Corona is accompanied by a loss of energy. This affects the transmission efficiency of the Line.
- (ii) Ozone is produced by corona and may cause corrosion of the conductor due to chemical action.
- (iii) The current drawn by the line due to corona is non-sinusoidal and hence non-sinusoidal voltage drop occurs in the line. This may cause inductive interference with neighboring communication lines.

2.19 Classification of O.H. Transmission lines

A transmission line has four constants R, L, C and shunt conductance. But generally, three constants R, L and C are considered and they are uniform along the whole length of line. The fourth constant shunt conductance between conductors or between conductor and ground and accounts for the leakage current at the insulators. It is very small in case of overhead lines and may be assumed zero. The capacitance existing between conductors for 1 ϕ line or 3 ϕ line forms a shunt path throughout the length of line. Therefore capacitance effects introduce complication in transmission line calculation.

Depending upon the manner in which capacitance is taken into account, the overhead transmission line are classified as

1. Short transmission lines
2. Medium transmission lines
3. Long transmission lines

• Short transmission lines

A short transmission line is one in which the line voltage is comparatively low ($< 20\text{kV}$) and the length of an overhead transmission line is upto about 50km. Due to smaller length and lower voltages the capacitance effects are small and hence can be neglected. Hence, whenever studying the performance of a short transmission line only resistance and inductance of the line are taken into consideration.

• Medium transmission lines

The transmission line having length of an overhead transmission line in the range 50-150 km and the line voltage is moderately high ($> 20\text{ kV} < 100\text{kV}$) is considered as a medium transmission line. Since the line is having sufficient length and line voltage, the capacitance effects are taken into consideration. For the propose of calculations, the distributed capacitance of the line is divided and lumped in the form of condensers shunted across the line at one or more points.

- **Long Transmission Line**

When the length of an overhead line is more than 150 km and the line voltage is very high (>100 kV), it is considered as long transmission line. For the treatment of such line, the line constants are considered uniformly distributed over the whole length of the line and rigorous methods are employed for solution.

2.20 Performance of single phase short Transmission line

The transmission lines which have length less than 50 km are generally referred as **short transmission lines**. For short length, the shunt capacitance of this type of line is neglected and other parameters like electrical resistance and inductor of these short lines are lumped, hence the equivalent circuit is represented as given below, Let's draw the vector diagram for this equivalent circuit, taking receiving end current I_r as reference. The sending end and receiving end voltages make angle with that reference receiving end current, of ϕ_s and ϕ_r , respectively.

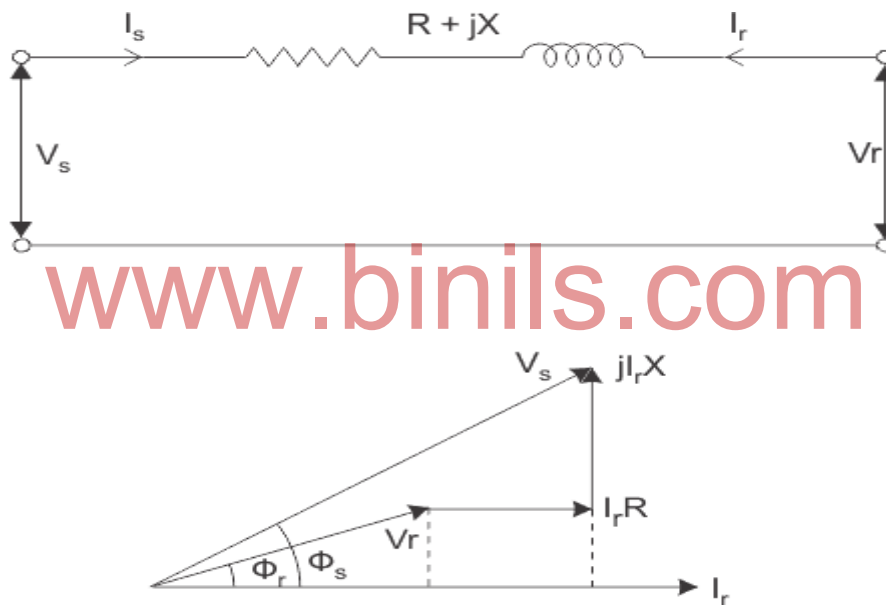

Figure 2.9

As the shunt capacitance of the line is neglected, hence sending end current and receiving end current is same, i.e. $I_s = I_r$.

Now if we observe the vector diagram carefully, we will get, V_s is approximately equal to

$$V_r + I_r \cdot R \cdot \cos\phi_r + I_r \cdot X \cdot \sin\phi_r$$

That means,

$$V_s \cong V_r + I_r \cdot R \cdot \cos\phi_r + I_r \cdot X \cdot \sin\phi_r \text{ as it is assumed that } \phi_s \cong \phi_r$$

As there is no capacitance, during no load condition the current through the line is considered as zero, hence at no load condition, receiving end voltage is the same as sending end voltage.

As per definition of voltage regulation of power transmission line,

$$\begin{aligned} \% \text{ regulation} &= \frac{V_s - V_r}{V_r} \times 100 \% \\ &= \frac{I_r R \cos \phi_r + I_r X \sin \phi_r}{V_r} \times 100 \% \\ \text{per unit regulation} &= \frac{I_r R}{V_r} \cos \phi_r + \frac{I_r X}{V_r} \sin \phi_r = v_r \cos \phi_r + v_x \sin \phi_r \end{aligned}$$

Here, v_r and v_x are the per unit resistance and reactance of the short transmission line respectively.

Any electrical network generally has two input terminals and two output terminals. If we consider any complex electrical network in a black box, it will have two input terminals and output terminals. This network is called two - port network. Two port model of a network simplifies the network solving technique. Mathematically a two port network can be solved by 2 by 2 matrix. A transmission as it is also an electrical network; line can be represented as two port network. Hence two port network of transmission line can be represented as 2 by 2 matrixes. Here the concept of ABCD parameters comes. Voltage and currents of the network can be represented as ,

$$V_s = AV_r + BI_r \dots\dots\dots (1)$$

$$I_s = CV_r + DI_r \dots\dots\dots (2)$$

Where, A, B, C and D are different constant of the network. If we put $I_r = 0$ at equation (1), we get,

$$A = \left. \frac{V_s}{V_r} \right|_{I_r = 0}$$

Hence, A is the voltage impressed at the sending end per voltage at the receiving end when receiving end is open. It is dimension less. If we put $V_r = 0$ at equation (1), we get

$$B = \left. \frac{V_s}{I_r} \right|_{V_r = 0}$$

That indicates it is impedance of the transmission line when the receiving terminals are short circuited. This parameter is referred as transfer impedance.

$$C = \left. \frac{I_s}{V_r} \right|_{I_r = 0}$$

C is the current in amperes into the sending end per voltage on open circuited receiving end. It has the dimension of admittance.

$$D = \left. \frac{I_s}{I_r} \right|_{V_r = 0}$$

D is the current in amperes into the sending end per amp on short circuited receiving end. It is dimensionless.

Now from equivalent circuit, it is found that, $V_s = V_r + I_r Z$ and $I_s = I_r$

Comparing these equations with equation 1 and 2

we get, $A = 1$, $B = Z$, $C = 0$ and $D = 1$. As we know that the constant A, B, C and D are related for passive network as,

$$AD - BC = 1.$$

Here, $A = 1$, $B = Z$, $C = 0$ and $D = 1$

$$\Rightarrow 1.1 - Z.0 = 1$$

So the values calculated are correct for short transmission line. From above equation (1),

$$V_s = AV_r + BI_r$$

When $I_r = 0$ that means receiving end terminals is open circuited and then from the equation 1, we get receiving end voltage at no load.

$$V_r' = \frac{V_s}{A}$$

and as per definition of voltage regulation of power transmission line,

$$\% \text{ voltage regulation} = \frac{V_s / A - V_r}{V_r} \times 100 \%$$

Efficiency of Short Transmission Line

The efficiency of short line as simple as efficiency equation of any other electrical equipment, that means

$$\% \text{ efficiency } (\mu) = \frac{\text{Power received at receiving end}}{\text{Power delivered at sending end}} \times 100 \%$$

$$\% \mu = \frac{\text{Power received at receiving end}}{\text{Power received at receiving end} + 3I_r^2 R} \times 100 \%$$

Example 1

A single phase overhead transmission line delivers 1100 kW at 33 kV at 0.8 p.f. lagging. The total resistance and inductive reactance of the line are 10 Ω and 15 Ω respectively.

Determine:

(i) sending end voltage (ii) Sending end power factor and (iii) Transmission efficiency.

Solution.

Load power factor, $\cos \phi_R = 0.8$ lagging

Total line impedance, $Z = R + jXL = 10 + j15$

Receiving end voltage, $V_R = 33 \text{ kV} = 33,000 \text{ V}$

$$\therefore \text{Line current, } I = \frac{kW \times 10^3}{V_R \cos \phi_R} = \frac{1100 \times 10^3}{33,000 \times 0.8} = 41.67 \text{ A}$$

$$\text{As } \cos \phi_R = 0.8 \quad \therefore \sin \phi_R = 0.6$$

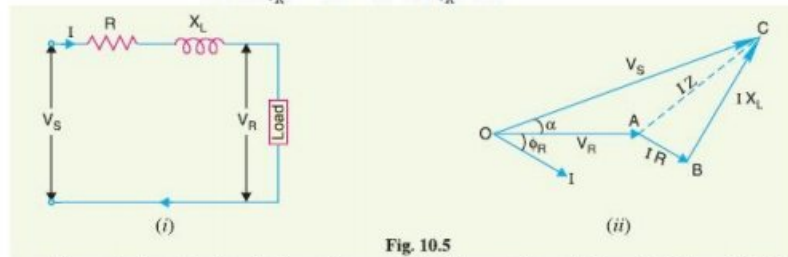

Fig. 10.5

The equivalent circuit and phasor diagram of the line are shown in Figs. 10.5 (i) and 10.5 (ii) respectively. Taking receiving end voltage \vec{V}_R as the reference phasor,

$$\vec{V}_R = V_R + j0 = 33000 \text{ V}$$

$$\begin{aligned} \vec{I} &= I(\cos \phi_R - j \sin \phi_R) \\ &= 41.67(0.8 - j0.6) = 33.33 - j25 \end{aligned}$$

$$\begin{aligned} \text{(i) Sending end voltage, } \vec{V}_S &= \vec{V}_R + \vec{I} \vec{Z} \\ &= 33,000 + (33.33 - j25)(10 + j15) \\ &= 33,000 + 333.3 - j250 + j375 \\ &= 33,708.3 + j250 \end{aligned}$$

$$\therefore \text{Magnitude of } V_S = \sqrt{(33,708.3)^2 + (250)^2} = 33,709 \text{ V}$$

(ii) Angle between \vec{V}_S and \vec{V}_R is

$$\alpha = \tan^{-1} \frac{250}{33,708.3} = \tan^{-1} 0.0074 = 0.42^\circ$$

\(\therefore\) Sending end power factor angle is

$$\phi_S = \phi_R + \alpha = 36.87^\circ + 0.42^\circ = 37.29^\circ$$

\(\therefore\) Sending end p.f., $\cos \phi_S = \cos 37.29^\circ = 0.7956$ lagging

(iii) Line losses = $I^2 R = (41.67)^2 \times 10 = 17,364 \text{ W} = 17.364 \text{ kW}$

Output delivered = 1100 kW

Power sent = 1100 + 17.364 = 1117.364 kW

\(\therefore\) Transmission efficiency = $\frac{\text{Power delivered}}{\text{Power sent}} \times 100 = \frac{1100}{1117.364} \times 100 = 98.44\%$

Note. V_S and ϕ_S can also be calculated as follows :

$$\begin{aligned} V_S &= V_R + IR \cos \phi_R + IX_L \sin \phi_R \text{ (approximately)} \\ &= 33,000 + 41.67 \times 10 \times 0.8 + 41.67 \times 15 \times 0.6 \\ &= 33,000 + 333.36 + 375.03 \end{aligned}$$

= 33708.39 V which is approximately the same as above

$$\begin{aligned} \cos \phi_S &= \frac{V_R \cos \phi_R + IR}{V_S} = \frac{33,000 \times 0.8 + 41.67 \times 10}{33,708.39} = \frac{26,816.7}{33,708.39} \\ &= 0.7958 \end{aligned}$$

Example 2

What is the maximum length in km for a 1-phase transmission line having copper conductor of 0.775 cm^2 cross-section over which 200 kW at unity power factor and at 3300V are to be delivered ? The efficiency of transmission is 90%. Take specific resistance as $1.725 \mu \Omega \text{ cm}$.

Solution.

$$\begin{aligned}\text{Receiving end power} &= 200 \text{ kW} = 2,00,000 \text{ W} \\ \text{Transmission efficiency} &= 0.9\end{aligned}$$

$$\therefore \text{Sending end power} = \frac{2,00,000}{0.9} = 2,22,222 \text{ W}$$

$$\therefore \text{Line losses} = 2,22,222 - 2,00,000 = 22,222 \text{ W}$$

$$\text{Line current, } I = \frac{200 \times 10^3}{3,300 \times 1} = 60.6 \text{ A}$$

Let $R \Omega$ be the resistance of one conductor.

$$\text{Line losses} = 2 I^2 R$$

or
$$22,222 = 2 (60.6)^2 \times R$$

$$\therefore R = \frac{22,222}{2 \times (60.6)^2} = 3.025 \Omega$$

Now,
$$R = \rho l/a$$

$$\therefore l = \frac{Ra}{\rho} = \frac{3.025 \times 0.775}{1.725 \times 10^{-6}} = 1.36 \times 10^6 \text{ cm} = 13.6 \text{ km}$$

2.21 H.V.D.C Transmission:

D.C. transmission.

For some years past, the transmission of electric power by D.C. has been receiving the active consideration of engineers due to its numerous advantages.

Advantages.

The high voltage d.c. transmission has the following advantages over high voltage a.c. transmission :

- (i) It requires only two conductors as compared to three for a.c. transmission.
- (ii) There is no inductance, capacitance, phase displacement and surge problems in d.c. transmission.
- (iii) Due to the absence of inductance, the voltage drop in a d.c. transmission line is less than the a.c. line for the same load and sending end voltage. For this reason, a d.c. transmission line has better voltage regulation.

- (iv) There is no skin effect in a d.c. system. Therefore, entire cross-section of the line conductor is utilized.
- (v) For the same working voltage, the potential stress on the insulation is less in case of d.c. system than that in a.c. system. Therefore, a d.c. line requires less insulation.
- (vi) A d.c. line has less corona loss and reduced interference with communication circuits.
- (vii) The high voltage d.c. transmission is free from the dielectric losses, particularly in the case of cables.
- (viii) In d.c. transmission, there are no stability problems and synchronising difficulties.

Disadvantages

- (i) Electric power cannot be generated at high D.C. voltage due to commutation problems.
- (ii) The D.C. voltage cannot be stepped up for transmission of power at high voltages.
- (iii) The D.C. switches and circuit breakers have their own limitations.

2.22 Layout Scheme and principle of High Voltage D.C Transmission

In generating substation, AC power is generated which can be converted into DC by using a rectifier. In HVDC substation or converter substation rectifiers and inverters are placed at both the ends of a line. The terminal substation, which converts AC into DC is called a rectifier terminal, while the terminal substation which converts DC into AC is called an inverter terminal.

The DC is flowing with the overhead lines and at the user end again DC is converted into AC by using inverters, which are placed in converter substation. The power remains the same at the sending and receiving ends of the line. DC is transmitted over long distances because it decreases the losses and improves the efficiency.

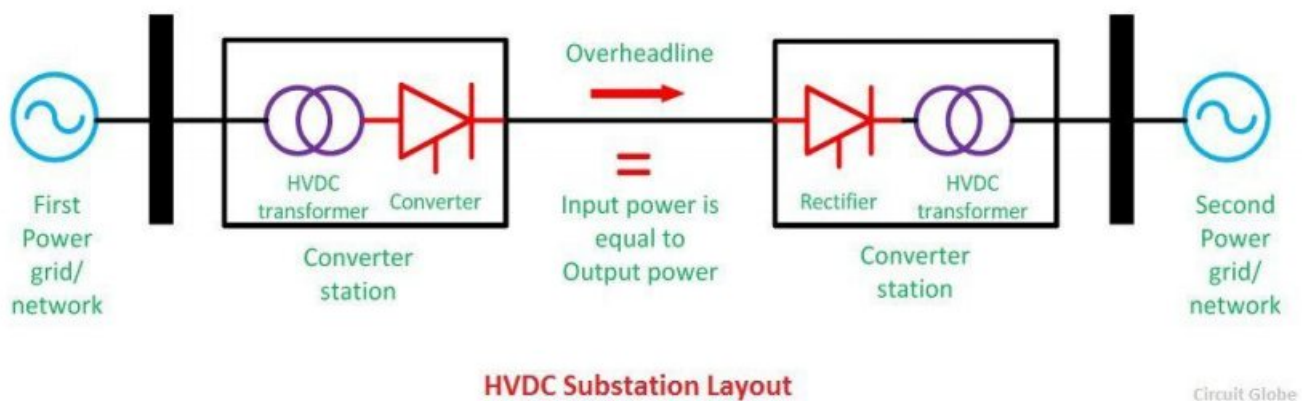

A system having more than two converter stations and one transmission line is called a 'two terminal DC system' or a 'point-to-point system'. Similarly, if substation has more than two converter stations and interconnecting DC terminal lines, it is called multiterminal DC substation.

2.23 D.C link configurations

HVDC links are classified into three type. These links are explained below;

Monopolar link – It has a single conductor of negative polarity and uses earth or sea for the return path of current. Sometimes the metallic return is also used. In Monopolar link, two converters are placed at the end of each pole. Earthing of poles is done by earth electrodes placed about 15 to 55 km away from the respective terminal stations. But this link has several disadvantages because it uses earth as a return path. Monopolar link is not much in use nowadays.

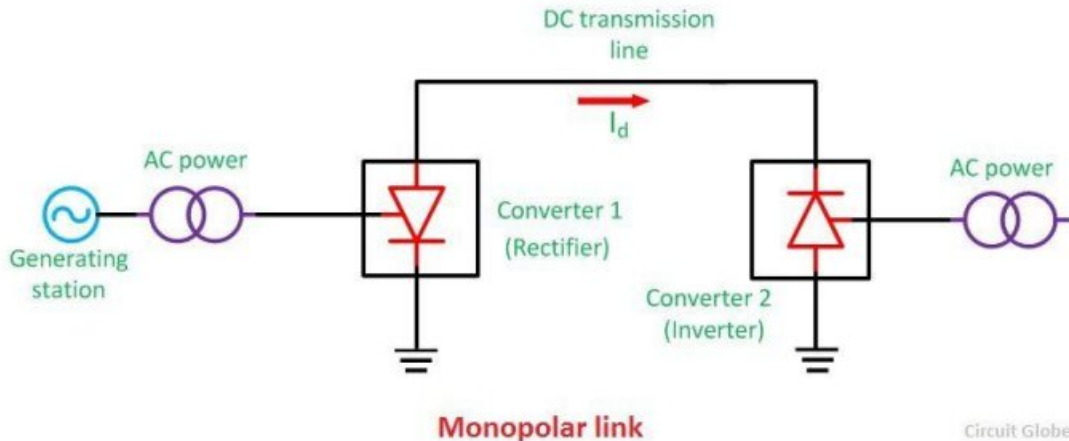

Bipolar link –

A bipolar link has two conductors, one positive and the other negative with respect to earth. The midpoints of converters at each terminal station are earthed via electrode lines. The voltage between the conductors is equal to two times the voltages between either of the two conductors and ground. Since one conductor is at the positive polarity with respect to earth and other is at negative polarity with respect to earth. In bipolar link when one pole goes out of operation, the system may be changed to the monopolar mode with the ground return. Thus, the system continues to supply the half rated power. Bipolar links are most commonly used in all high power HVDC systems.

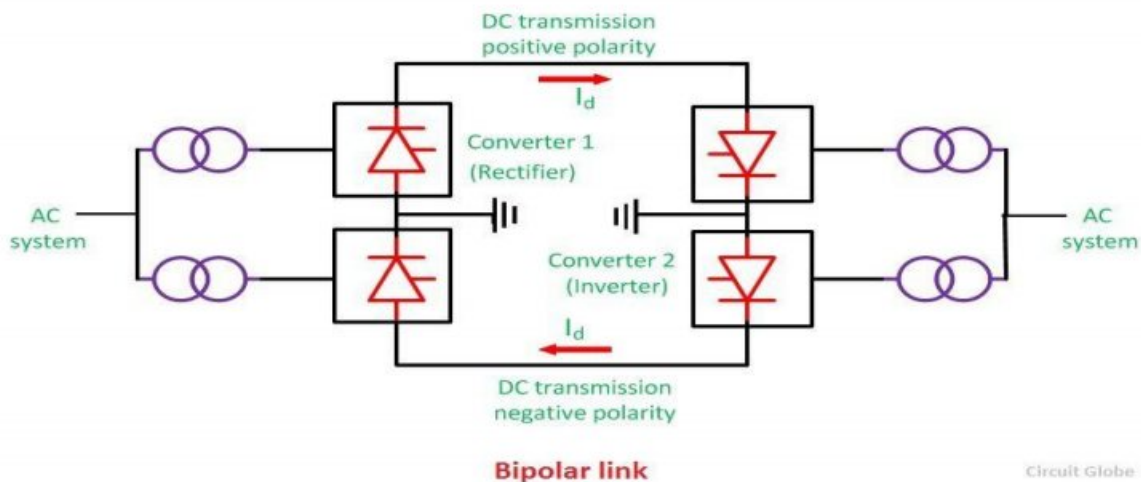

Homopolar link–

It has two conductors of the same polarity usually negative polarity, and always operates with earth or metallic return. In the homopolar link, poles are operated in parallel, which reduces the insulation cost. This system is not used presently.

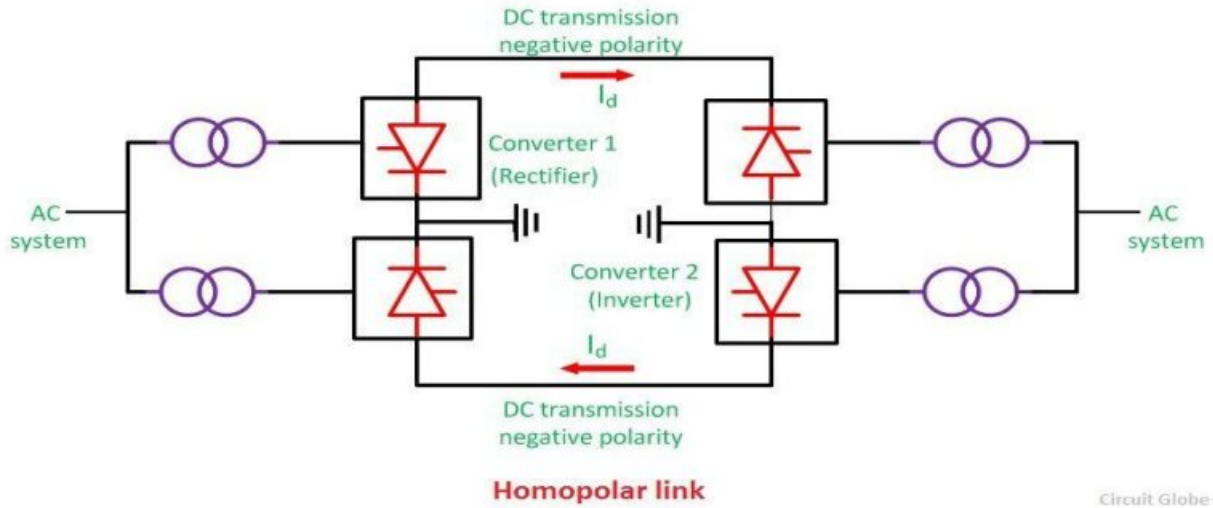

2.24 HVDC converter Station

www.binils.com

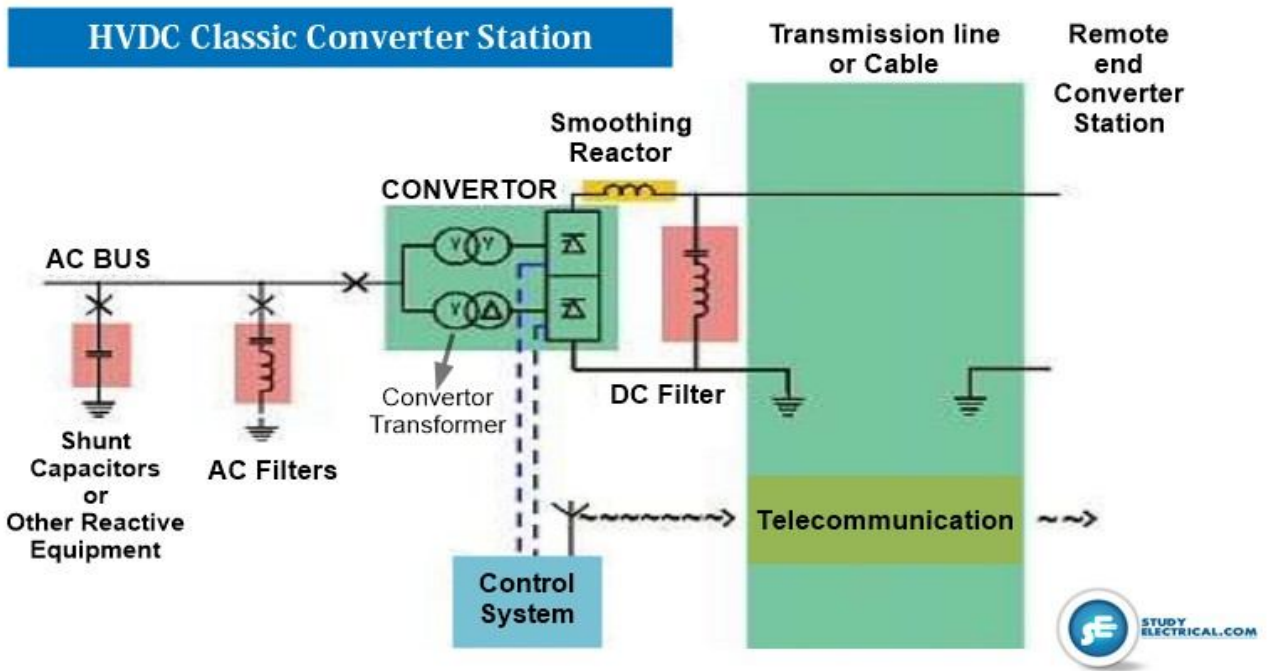

REVIEW QUESTION

2MARKS & 3MARKS

1. What are elements used in transmission line.
2. What is meant by sag?
3. What are the different types of supports?
4. What are the factors influencing the sag?
5. Write the expression for sag for support at equal level?
6. Write the expression for sag for support at unequal level?
7. State the merits and demerits of RCC poles.
8. State Kelvin's law.
9. Expand the term ACSR.
10. What is skin effect?
11. What is corona?
12. What is Ferranti effect?
13. What is meant by regulation of transmission line
14. State why transmission line conductors are interchanged at regular intervals
15. Write the expression for corona loss.

10 MARKS

1. Draw and explain the typical layout AC power supply scheme.
2. State and explain the typical layout of Kelvin's law.
3. Write the limitation of Kelvin's law.
4. Explain the regulation and efficacy of transmission line.
5. Explain the effects of wind and ice loading in transmission lines.
6. Explain transposition of transmission line.
7. What is meant by skin effect and write the factor on which it depends?
8. Explain Ferranti effect.
9. Draw layout diagram and explain the principle of HVDC transmission line.
10. Write short note on spacing between the conductors.
11. Explain different line supports used in transmission line.
12. Derive an expression for the sag in a transmission line conductor suspended between two supports at the same level and unequal level.
13. Explain how to find the regulation and efficacy of short transmission line.
14. What is corona? And explain the corona formation in transmission line

UNIT 3

LINE INSULATORS

3.1.1 Introduction

Overhead line conductors are bare and not covered with any insulated coating. They are secured to the supporting structures by means of insulating fittings, called insulators. The Insulators provide necessary insulation between line conductors and supports and thus prevents any leakage current from conductors to earth.

3.1.2 Overhead line insulators

They should have the following properties:

- (i) High mechanical strength in order to withstand conductor load, wind load etc.
- (ii) High electrical resistance of insulator material in order to avoid leakage currents to earth.
- (iii) High relative permittivity of insulator material in order that dielectric strength is high.
- (iv) The insulator material should be non-porous, free from impurities and cracks otherwise the permittivity will be lowered.
- (v) High ratio of puncture strength to flashover.

3.1.3 Materials used for insulator

The most commonly used material for insulators of overhead line is porcelain but glass, steatite and special composition materials are also used to a limited extent. Porcelain is produced by firing at a high temperature a mixture of kaolin, feldspar and quartz. It is stronger mechanically than glass, gives less trouble from leakage and is less affected by changes of temperature.

3.1.4 Types of electrical insulators in overhead lines:

There are several types of insulators but the most commonly used are

- pin type
- suspension type
- strain insulator
- Shackle insulator.
- Stay insulator

3.1.4.1 Pin type insulators:

The part section of a pin type insulator is shown in Figure 3.1. As the name suggests, the pin type insulator is secured to the cross-arm on the pole. There is a groove on the upper end of the insulator for housing the conductor. The conductor passes through this groove and is bound by the annealed wire of the same material as the conductor. A pin insulator is usually made from porcelain, but glass or plastic may also be used in some cases. As pin insulators are almost always employed in open air, proper insulation while raining is also an important consideration. A wet pin insulator may provide a path for current to flow towards the pole. To overcome this problem, pin insulators are designed with rain sheds or petticoats.

Pin type insulators are used for transmission and distribution of electric power at voltages upto 33 kV. Beyond operating voltage of 33 kV, the pin type insulators become too bulky and hence uneconomical.

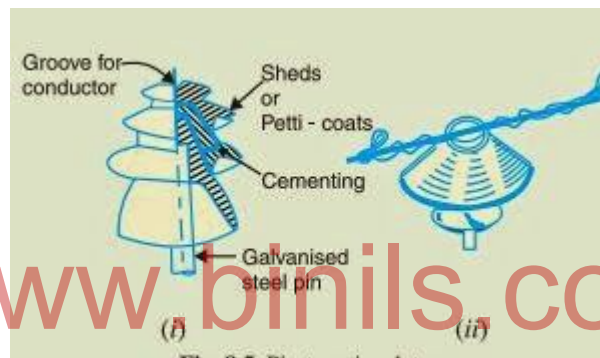

Fig 3.1

3.1.4.2 Suspension type insulators:

The cost of pin type insulator increases rapidly as the working voltage is increased. Therefore, this type of insulator is not economical beyond 33 kV. For high voltages (>33 kV), it is a usual practice to use suspension type insulators shown in Figure 3.2. They consist of a number of porcelain discs connected in series by metal links in the form of a string. The conductor is suspended at the bottom end of this string while the other end of the string is secured to the cross-arm of the tower. Each unit or disc is designed for low voltage; say 11 kV. The number of discs in series would obviously depend upon the working voltage. For instance, if the working voltage is 66 kV, then six discs in series will be provided on the string.

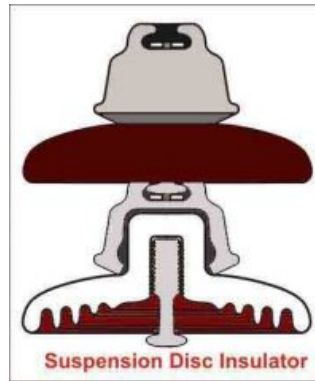

Fig 3.2

Advantages:

- (i) Suspension type insulators are cheaper than pin type insulators for voltages beyond 33 kV.
- (ii) Each unit or disc of suspension type insulator is designed for low voltage, usually 11 kV.

Depending upon the working voltage, the desired number of discs can be connected in series.

(iii) If any one disc is damaged, the whole string does not become useless because the damaged disc can be replaced by the sound one.

(iv) The suspension arrangement provides greater flexibility to the line. The connection at the cross arm is such that insulator string is free to swing in any direction and can take up the position where mechanical stresses are minimum.

(v) In case of increased demand on the transmission line, it is found more satisfactory to supply the greater demand by raising the line voltage than to provide another set of conductors. The additional insulation required for the raised voltage can be easily obtained in the suspension arrangement by adding the desired number of discs.

(vi) The suspension type insulators are generally used with steel towers. As the conductors run below the earthed cross-arm of the tower, therefore, this arrangement provides partial protection from lightning.

Disadvantages of Suspension Insulator

1. Suspension insulator string costlier than pin and post type insulator.
2. Suspension string requires more height of supporting structure than that for pin or post insulator to maintain same ground clearance of current conductor.
3. The amplitude of free swing of conductors is larger in suspension insulator system, hence, more spacing between conductors should be provided.

3.1.4.3 Strain insulators:

When there is a dead end of the line or there is corner or sharp curve, the line is subjected to greater tension. In order to relieve the line of excessive tension, strain insulators are used. For low voltage lines (< 11 kV), shackle insulators are used as strain insulators. However, for high voltage transmission lines, strain insulator consists of an assembly of suspension insulators as shown in Figure. The discs of strain insulators are used in the vertical plane. When the tension in lines is exceedingly high, as at long river spans, two or more strings are used in parallel.

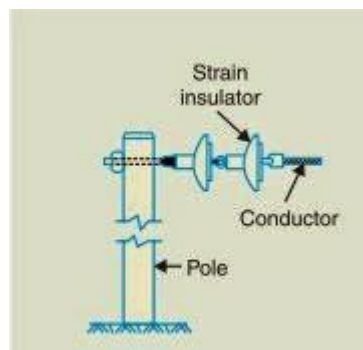

Fig 3.3

When suspension string is used to sustain extraordinary tensile load of conductor it is referred as string insulator. When there is a dead end or there is a sharp corner in transmission line, the line has to sustain a great tensile load of conductor or strain. A strain insulator must have considerable mechanical strength as well as the necessary electrical insulating properties.

3.1.4.4 Stay Insulator

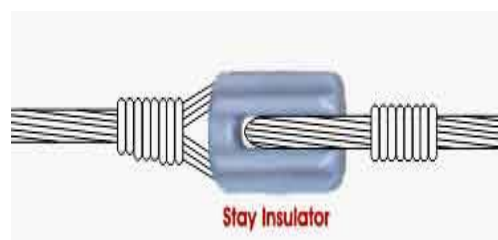

Fig 3.4

For low voltage lines, the stays are to be insulated from ground at a height. The insulator used in the stay wire is called as the stay insulator and is usually of porcelain and is so designed that in case of breakage of the insulator the guy-wire will not fall to the ground.

3.1.4.5 Shackle insulators:

In early days, the shackle insulators were used as strain insulators. But now a days, they are frequently used for low voltage distribution lines. Such insulators can be used either in a horizontal position or in a vertical position. They can be directly fixed to the pole with a bolt or to the cross arm. Figure 3.5 shows a shackle insulator fixed to the pole. The conductor in the groove is fixed with a soft binding wire.

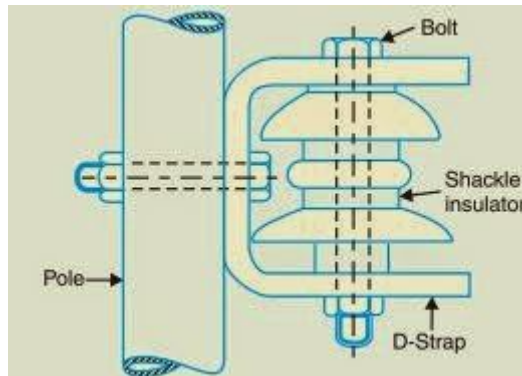

Fig 3.5

3.1.5 Causes of Insulator Failure

There are different causes due to which failure of insulation in electrical power system may occur.

- **Cracking of Insulator**

The porcelain insulator mainly consists of three different materials. The main porcelain body, steel fitting arrangement and cement to fix the steel part with porcelain. Due to changing climate conditions, these different materials in the insulator expand and contract in different rate. These unequal expansion and contraction of porcelain, steel and cement are the chief cause of cracking of insulator.

- **Defective Insulation Material**

If the insulation material used for insulator is defective anywhere, the insulator may have a high chance of being punched from that place.

- **Porosity in the Insulation Materials**

If the porcelain insulator is manufactured at low temperatures, it will make it porous, and due to this reason it will absorb moisture from air thus its insulation will decrease and leakage current will start to flow through the insulator which will lead to insulator failure.

- **Improper Glazing on Insulator Surface**

If the surface of porcelain insulator is not properly glazed, moisture can stick over it. This moisture along with deposited dust on the insulator surface, produces a conducting path. As a result the flash over distance of the insulator is reduced. As the flash over distance is reduced, the chance of failure of insulator due to flash over becomes more.

- **Flash Over Across Insulator**

If flash over occurs, the insulator may be over heated which may ultimately results into shattering of it.

- **Mechanical Stresses on Insulator**

If an insulator has any weak portion due to manufacturing defect, it may break from that weak portion when mechanical stress is applied on it by its conductor. These are the main causes of insulator failure. Now we will discuss the different insulator test procedures to ensure minimum chance of failure of insulation.

3.1.6 Insulator Testing

Every electrical insulator must undergo the following tests

- Flashover tests of insulator
- Performance tests
- Routine tests

3.1.6.1 Flashover Test

There are mainly three types of flashover test performed on an insulator and these are-

➤ **Dry Flashover Test of Insulator**

First the insulator to be tested is mounted in the manner in which it would be used practically. Then terminals of variable power frequency voltage source are connected to the both electrodes of the insulator. Now the power frequency voltage is applied and gradually increased up to the specified value. This specified value is below the minimum flashover voltage. This voltage is maintained for one minute and observes that there should not be any flash-over or puncher occurred. The insulator must be capable of sustaining the specified minimum voltage for one minute without flash over.

➤ **Wet Flashover Test or Rain Test of Insulator**

In this test also the insulator to be tested is mounted in the manner in which it would be used practically. Then terminals of variable power frequency voltage source are connected to the both electrodes of the insulator. After that the insulator is sprayed with water at an angle of 45° in such a manner that its precipitation should not be more 5.08 mm per minute. The resistance of the water used for spraying must be between 9 kΩ 10 11 kΩ per cm³ at normal atmospheric pressure and temperature. In this way we create artificial raining condition. Now the power frequency voltage is applied and gradually increased up to the specified value.

This voltage is maintained for either one minute or 30 second as specified and observe that there should not be any flash-over or puncher occurred. The insulator must be capable of sustaining the specified minimum power frequency voltage for specified period without flash over in the said wet condition.

➤ **Frequency Flashover Voltage test of Insulator**

The insulator is kept in similar manner of previous test. In this test the applied voltage is gradually increased in similar to that of previous tests. But in that case the voltage when the surroundings air breaks down, is noted. Impulse Frequency Flashover Voltage Test of Insulator The overhead outdoor insulator must be capable of sustaining high voltage surges caused by lightning etc. So this must be tested against the high voltage surges.

The insulator is kept in similar manner of previous test. Then several hundred thousands Hz very high impulse voltage generator is connected to the insulator. Such a voltage is applied to the insulator and the spark over voltage is noted. The ratio of this noted voltage to the voltage reading collected from power frequency flash over voltage test is known as impulse ratio of insulator. This ratio should be approximately 1.4 for pin type insulator and 1.3 for suspension type insulators

3.1.6.2 Performance Test of Insulator

Now performance test of insulator is discussed

➤ **Temperature Cycle Test of Insulator**

The insulator is first heated in water at 70°C for one hour. Then this insulator immediately cooled in water at 7°C for another one hour. This cycle is repeated for three times. After completion of these three temperature cycles, the insulator is dried and the glazing of insulator is thoroughly observed. After this test there should not be any damaged or deterioration in the glaze of the insulator surface.

➤ **Puncture Voltage Test of Insulator**

The insulator is first suspended in insulating oil. Then voltage of 1.3 times of flash over voltage, is applied to the insulator good insulator should not puncture under this condition.

➤ **Porosity Test of Insulator**

The insulator is first broken into pieces. Then These broken pieces of insulator are immersed in a 0.5 % alcohol solution of fuchsin dye under pressure of about 140.7 kg/cm² for 24 hours. After that the sample are removed and examine. The presence of a slight porosity in the material is indicated by a deep penetration of the dye into it.

➤ **Mechanical Strength Test of Insulator**

The insulator is applied by 2½ times the maximum working strength for about one minute. The insulator must be capable of sustaining this much mechanical stress for one minute without any damage in it.

3.1.6.3. Routine Test of Insulator

Each of the insulators must undergo the following routine test before they are recommended for using at site.

➤ **Proof Load Test of Insulator**

In proof load test of insulator, a load of 20% in excess of specified maximum working load is applied for about one minute to each of the insulator.

➤ **Corrosion Test of Insulator**

In corrosion test of insulator, The insulator with its galvanized or steel fittings is suspended into a copper sulfate solution for one minute. Then the insulator is removed from the solution and wiped, cleaned. Again it is suspended into the copper sulfate solution for one

minute..The process is repeated for four times. Then it should be examined and there should not be any disposition of metal on it.

3.1.7 Potential distribution over a string of suspension insulators:

A string of suspension insulators consists of a number of porcelain discs connected in series through metallic links. Figure 3.6(i) show 3-disc string of suspension insulators. The porcelain portion of each disc is in between two metal links. Therefore, each disc forms a capacitor C as shown in Figure 3.6(ii). This is known as mutual capacitance or self-capacitance. If there were mutual capacitance alone, then charging current would have been the same through all the discs and consequently voltage across each unit would have been the same i.e., $V/3$ as shown in Figure 3.6(ii). However, in actual practice, capacitance also exists between metal fitting of each disc and tower or earth. This is known as shunt capacitance C_1 . Due to shunt capacitance, charging current is not the same through all the discs of the string. Therefore, voltage across each disc will be different. Obviously, the disc nearest to the line conductor will have the maximum voltage. Thus referring to Figure 3.6 (iii), V_3 will be much more than V_2 or V_1 .

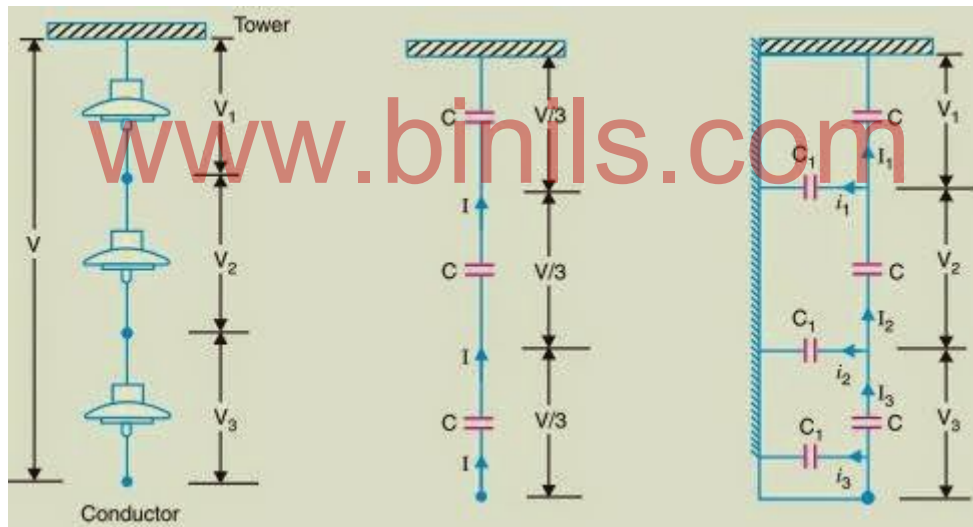

Fig 3.5

The following points may be noted regarding the potential distribution over a string of suspension insulators :

- (i) The voltage impressed on a string of suspension insulators does not distribute itself uniformly across the individual discs due to the presence of shunt capacitance.
- (ii) The disc nearest to the conductor has maximum voltage across it. As we move towards the cross-arm, the voltage across each disc goes on decreasing.
- (iii) The unit nearest to the conductor is under maximum electrical stress and is likely to be punctured. Therefore, means must be provided to equalize the potential across each unit.

(iv) If the voltage impressed across the string were D.C., then voltage across each unit would be the same. It is because insulator capacitances are ineffective for d.c.

To find voltage

Figure below shows the equivalent circuit for a 3-disc string. Let us suppose that self capacitance of each disc is C . Let us further assume that shunt capacitance C_1 is some fraction K of self capacitance i.e., $C_1 = KC$. Starting from the cross-arm or tower, the voltage across each unit is V_1, V_2 and V_3 respectively as shown.

Applying Kirchoff's current law to node A, we get,

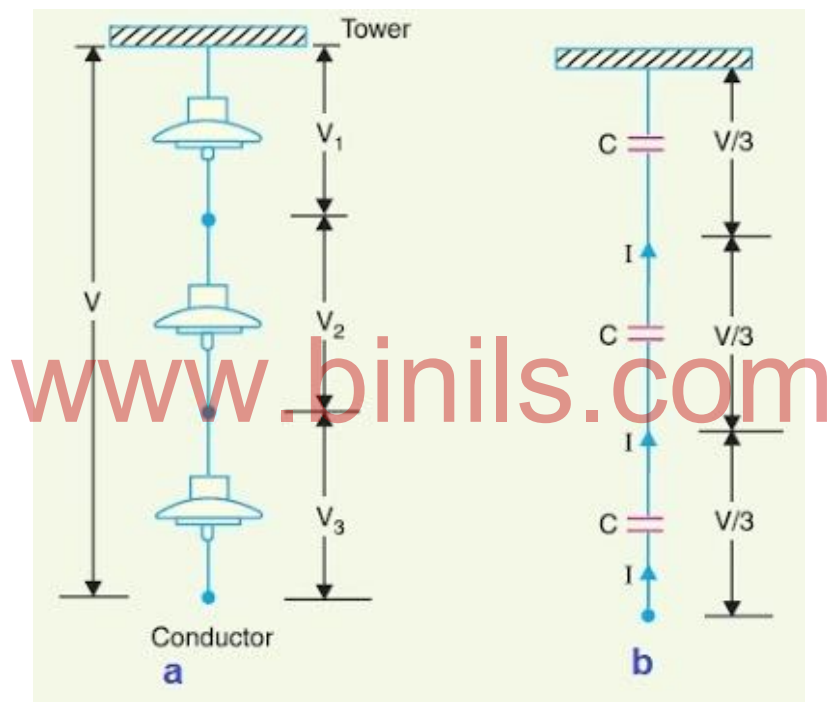

$$I_2 = I_1 + i_1$$

or

$$V_2 \omega C = V_1 \omega C + V_1 \omega C_1$$

or

$$V_2 \omega C = V_1 \omega C + V_1 \omega KC$$

$$\therefore V_2 = V_1(1 + K) \dots(i)$$

Applying Kirchoff's current law to node B, we get,

$$I_3 = I_2 + i_2$$

$$V_3 \omega C = V_2 \omega C + (V_1 + V_2) \omega C_1$$

or $V_3 \omega C = V_2 \omega C + (V_1 + V_2) \omega K C$

or $V_3 = V_2 + (V_1 + V_2)K$
 $= KV_1 + V_2(1 + K)$

$$\begin{aligned}
 &= KV_1 + V_1(1 + K)^2 \\
 &= V_1[K + (1 + K)^2] \\
 V_3 &= V_1[1 + 3K + K^2] \\
 V &= V_1 + V_2 + V_3 \\
 &= V_1 + V_1(1 + K) + V_1(1 + 3K + K^2) \\
 &= V_1(3 + 4K + K^2) \\
 V &= V_1(1 + K)(3 + K)
 \end{aligned}$$

String efficiency:

The ratio of voltage across the whole string to the product of number of discs and the voltage across the disc nearest to the conductor is known as string efficiency i.e.,

$$\text{string efficiency} = \frac{\text{voltage across string}}{n \times \text{voltage across disc nearest conductor}}$$

Where n = number of discs in the string.

www.binils.com

String efficiency is an important consideration since it decides the potential distribution along the string. The greater the string efficiency, the more uniform is the voltage distribution. Thus 100% string efficiency is an ideal case for which the voltage across each disc will be exactly the same. Although it is impossible to achieve 100% string efficiency, yet efforts should be made to improve it as close to this value as possible.

Methods of Improving String Efficiency

The maximum voltage appears across the insulator nearest to the line conductor and decreases progressively as the cross arm is approached. If the insulation of the highest stressed insulator (i.e. nearest to conductor) breaks down or flash over takes place, the breakdown of other units will take place in succession. This necessitates equalizing the potential across the various units of the string i.e. to improve the string efficiency.

The various methods for this purpose are:

1. **By using longer cross-arms.**

The value of string efficiency depends upon the value of K i.e., ratio of shunt capacitance to mutual capacitance. The lesser the value of K, the greater is the string efficiency and more uniform is the voltage distribution. The value of K can be decreased by reducing the shunt

capacitance. In order to reduce shunt capacitance, the distance of conductor from tower must be increased i.e., longer cross-arms should be used. However, limitations of cost and strength of tower do not allow the use of very long cross-arms. In practice, $K = 0.1$ is the limit that can be achieved by this method.

2. By grading the insulators.

In this method, insulators of different dimensions are so chosen that each has a different capacitance. The insulators are capacitance graded i.e. they are assembled in the string in such a way that the top unit has the minimum capacitance, increasing progressively as the bottom unit (i.e., nearest to conductor) is reached. Since voltage is inversely proportional to capacitance, this method tends to equalize the potential distribution across the units in the string. This method has the disadvantage that a large number of different-sized insulators are required. However, good results can be obtained by using standard insulators for most of the string and larger units for that near to the line conductor.

3. By using a guard ring.

The potential across each unit in a string can be equalized by using a guard ring which is a metal ring electrically connected to the conductor and surrounding the bottom insulator. The guard ring introduces capacitance between metal fittings and the line conductor. The guard ring is contoured in such a way that shunt capacitance currents i_1, i_2 etc. are equal to metal fitting line capacitance currents i'_1, i'_2 etc. The result is that same charging current I flows through each unit of string. Consequently, there will be uniform potential distribution across the units.

3.1.8 Corona

The phenomenon of violet glow, hissing noise and production of ozone gas in an overhead transmission line is known as corona.

Parameters of corona

- Corona is caused by the ionization of the media (air) surrounding the electrode (conductor)
- Corona onset is a function of voltage
- Corona onset is a function of relative air density
- Corona onset is a function of relative humidity

1. Corona and the Electric Field

- Corona is NOT solely a function of the Electric Field
- Corona is a function of the electric field on the surface of the electrode (conductor)
- Corona is also a function of the radius of curvature of the electrode (conductor)

- Corona is also a function of the rate of decay of the electric field away from the electrode (conductor)
- For the preceding reasons, selecting the conductor with the smallest electric field at its surface is not correct.

2. Corona and the Relative Air Density

- Corona has an inverse relationship with air density
- Standard line designs that perform well at sea level, may have significant corona issues if used on lines that are installed over mountainous areas

3. Corona and the Humidity

- Corona has an inverse relationship with humidity at power frequencies
- Fair weather corona is more prevalent in low humidity environments

4. Corona is Dependent Surface Condition of the Conductors

- Corona is enhanced by irregularities on the conductor surface
- Irregularities include: dust, insects, burrs and scratches and water drops present on new conductors
- Corona will generally be greater on new conductors and will decrease to a steady-state value over a period of approximately one year in-service
- Corona is significantly increased in foul weather.

3.1.9 Methods To Reduce Corona Discharge Effect:

- Corona can be avoided
 1. **By minimizing the voltage stress and electric field gradient.:** This is accomplished by using utilizing good high voltage design practices, i.e., maximizing the distance between conductors that have large voltage differentials, using conductors with large radii, and avoiding parts that have sharp points or sharp edges.
 2. **Surface Treatments:** Corona inception voltage can sometimes be increased by using a surface treatment, such as a semiconductor layer, high voltage putty or corona dope.
 3. **Homogenous Insulators:** Use a good, homogeneous insulator. Void free solids, such as properly prepared silicone and epoxy potting materials work well.
 4. **If you are limited to using air as your insulator,** then you are left with geometry as the critical parameter. Finally, ensure that steps are taken to reduce or eliminate unwanted voltage transients, which can cause corona to start.

5. **Using Bundled Conductors:** on our 345 kV lines, we have installed multiple conductors per phase. This is a common way of increasing the effective diameter of the conductor, which in turn results in less resistance, which in turn reduces losses.
6. **Elimination of sharp points:** electric charges tend to form on sharp points; therefore when practicable we strive to eliminate sharp points on transmission line components.
7. **Using Corona rings:** On certain new 345 kV structures, we are now installing corona rings. These rings have smooth round surfaces which are designed to distribute charge across a wider area, thereby reducing the electric field and the resulting corona discharges.
8. **Whether:** Corona phenomena much worse in foul weather, high altitude
9. **New Conductor:** New conductors can lead to poor corona performance for a while.
10. **By increasing the spacing between the conductors:** Corona Discharge Effect can be reduced by increasing the clearance spacing between the phases of the transmission lines. However increase in the phase's results in heavier metal supports. Cost and Space requirement increases.
11. **By increasing the diameter of the conductor:** Diameter of the conductor can be increased to reduce the corona discharge effect. By using hollow conductors corona discharge effect can be improved.

Advantages

- Due to corona formation, the air surrounding the conductor becomes conducting and hence virtual diameter of the conductor is increased. The increased diameter reduces the electro-static stresses between the conductors.
- Corona reduces the effects of transients produced by surges.
-

Disadvantages

- Corona is accompanied by a loss of energy. This affects the transmission efficiency of the line.
- Ozone is produced by corona and may cause corrosion of the conductor due to chemical action.

UNDERGROUND CABLES

3.2.1 Introduction

An underground cable essentially consists of one or more conductors covered with suitable insulation and surrounded by a protecting cover.

3.2.2 Requirement of cables

- The conductor used in cables should be tinned stranded copper or aluminum of high conductivity. Stranding is done so that conductor may become flexible and carry more current.
- The conductor size should be such that the cable carries the desired load current without overheating and causes voltage drop within permissible limits.

- The cable must have proper thickness of insulation in order to give high degree of safety and reliability at the voltage for which it is designed.
- The cable must be provided with suitable mechanical protection so that it may withstand the rough use in laying it.
- The materials used in the manufacture of cables should be such that there is complete chemical and physical stability throughout.

3.2.3 VARIOUS PARTS OF THREE CONDUCTOR UG CABLE

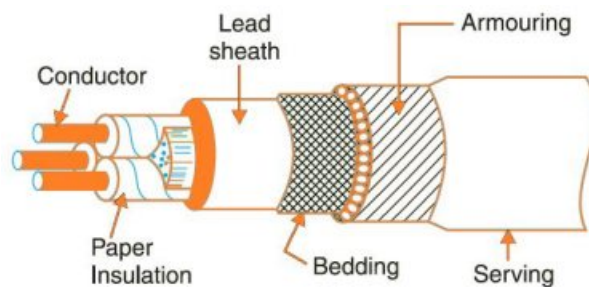

Fig no 3.7

•Cores or Conductors

A cable may have one or more than one core (conductor) depending upon the type of service for which it is intended. For instance, the 3-conductor cable shown in Figure 3.7 is used for 3-phase service. The conductors are made of tinned copper or aluminum and are usually stranded in order to provide flexibility to the cable.

• Insulation:

Each core or conductor is provided with a suitable thickness of insulation, the thickness of layer depending upon the voltage to be withstood by the cable. The commonly used materials for insulation are impregnated paper, varnished cambric or rubber mineral compound.

• Metallic sheath:

In order to protect the cable from moisture, gases or other damaging liquids (acids or alkalis) in the soil and atmosphere, a metallic sheath of lead or aluminum is provided over the insulation as shown in Figure3.7.

• Bedding:

Over the metallic sheath is applied a layer of bedding which consists of a fibrous material like jute or hessian tape. The purpose of bedding is to protect the metallic sheath against corrosion and from mechanical injury due to armoring.

- **Armoring**

Over the bedding armoring is provided which consist of one or two layers of galvanized steel wire or steel tape. Its purpose is to protect the cable from mechanical injuries while laying it or handling it. Armoring may not be done in the case of some cables.

- **Serving:**

In order to protect armoring from atmospheric conditions, a layer of fibrous material like jute similar to bedding is provided over the armoring. This is known as serving. Armoring and serving are only applied to the cables for the protection of conductor insulation and to protect metallic sheath from mechanical injury.

3.2.4 Classification of cables

- **Based on voltage rating**

- (i) Low-tension (L.T.) cables — up to 1000 V
- (ii) High-tension (H.T.) cables — up to 11,000 V
- (iii) Super-tension (S.T.) cables — from 22 kV to 33 kV
- (iv) Extra high-tension (E.H.T.) cables — from 33 kV to 66 kV
- (v) Extra super voltage cables — beyond 132 KV

- **No. of Conductors in Cable**

On the basis of number of conductors in the cable, cables are of two type's

- Single Core Cable(Single core cable have only one conductors)
- 3 Core Cable (three core cable has three conductors)

- **Power to be handled in Cable**

On the basis of amount of power to be transferred through the cable, cables are classified into two categories. These are

Power Cables: If large amount of power is to be transferred then these are called power cables. These are further classified on the basis of voltage at which power is to be delivered.

Low Voltage Power Cable: If the voltage in the cable is less than 1000 Volts or 1kV then the cable is called Low Voltage Power Cable.

High Voltage Power Cable: If the voltage in the cable is above 1000 Volts or 1kV then the cable is called High Voltage Power Cable.

Control Cables : If the cable is used to carry very low power signal generally for controlling equipments then the cables are called control cables.

3.2.5. Cables of 3-phase service:

In practice, underground cables are generally required to deliver 3-phase power. For the purpose, either three-core cable or three single core cables may be used. For voltages up to 66 kV, 3-core cable (i.e., multi-core construction) is preferred due to economic reasons. However, for voltages beyond 66 kV, 3-core-cables become too large and unwieldy and, therefore, single-core cables are used. The following types of cables are generally used for 3-phase service:

- Belted cables — up to 11 kV
- Screened cables — from 22 kV to 66 kV
- Pressure cables — beyond 66 kV.

3.2.5. 1. Belted cables

The cores in the belted underground cables are not circular and are insulated by impregnated paper. The cores are generally stranded and may be of non-circular shape to make better use of available space. In a 3 phase cable, the three cores are grouped together and then belted with the paper belt.

The gaps between the conductors and the paper insulation are filled with fibrous material such as the jute. This makes the cable to have a circular cross-sectional shape. A lead sheath is used to cover the belt hence protect it from moisture and provide mechanical strength. The lead sheath is then covered with a single or multiple layers of an armoring material and finally an outer cover.

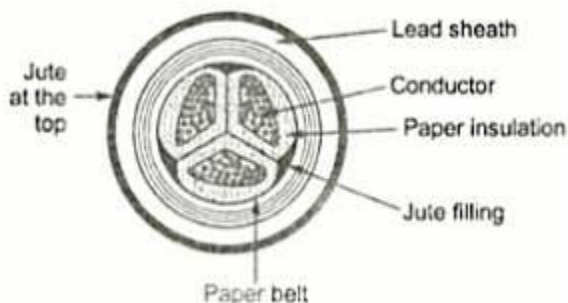

Fig 3.8

Disadvantages:

- Since the electrical field in the three core cables is tangential, the paper insulation and the fibrous materials are subjected to the tangential electrical stresses. This stresses weakens the fibrous material as well as the resistance and dielectric strength for the insulation along the tangential path.
- The weakening of the insulation may lead to the formation of air spaces in the insulation. Under high voltages the air may be ionized and cause deterioration and breakdown of insulation. For this reason, the belted cables are only suitable for voltages up to 11KV and not higher.
- Due to the large diameter of the paper belt, bending the cable may lead to the formation of wrinkles and gaps.

3.2.5. 2. Screened cables

These are used for the voltage levels of 22 kV and 33 kV. The two types of screened cables are

1. H type cables and
2. S.L. type cables.

H-Type Cables

The cable is designed by M. Hochstadter and hence the name given to it is H-Type cable. There is no paper belt in this type of cable. Each conductor in this cable is insulated with a paper, covered with a metallic screen which is generally an aluminium foil. The construction is shown in the Fig. 1. The metallic screen touches each other. Instead of paper belt, the three cores are wrapped with a conducting belt which is usually copper woven fabric tape. Then there is lead sheath.

The conducting belt is in electrical contact with the metallic screen and lead sheath. After lead sheath there are layers of bedding, armoring and serving. The metallic screen helps to completely impregnate the cable which avoids the possibility of formation of voids and spaces. The conducting belt, the three metallic screens and lead sheath are at earth potential, due to which electrical stresses are radial in nature. This keeps the dielectric losses to minimum. Another advantage of metallic screens is increase in the heat dissipation which reduces the sheath losses. Due to these advantages, current carrying capacity of these cables increase. In special cases, the use of these cables cable extended upto the 66 kV level.

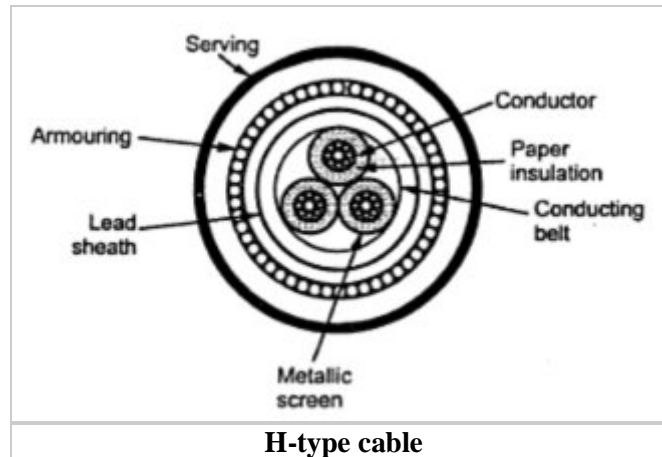

Fig 3.9

3.2.5. 3. S.L. Cables

The name S.L. stands for separate lead screened cables. In this cable, each core is insulated with impregnated paper and each one is then covered by separate lead sheath. Then there is a cotton tape covering the three cores together using a paper filler material. Then there are the layers of armouring and serving. the difference between H-type and S.L. type cable is that in S.L. type a common lead sheath covering all the three cores is absent while each core is provided with separate lead sheath. This allows bending of the cables as per the requirement. The construction of S.L. type cable is shown in the Fig.3.10

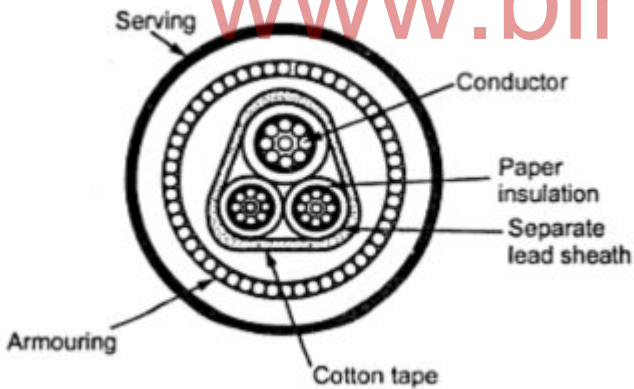

Fig 3.10

The three cores in this type of cable are as good as three separate single core cables.

Advantages

1. Due to lead individual lead sheath, core to core fault possibility gets minimized.
2. The electrical stresses are radial in nature.

3. Due to absence of overall lead sheath, bending of cable is easy.
4. The dielectric which gets subjected to electric stresses is paper which is homogeneous hence there is no possibility of formation of voids.
5. Metal sheath increases the heat dissipation which increases the current carrying capacity.

3.2.6. Pressures cables

These are high power cables used for voltages above 66KV. The cable construction is different from the above two and majority uses a cooling gas or oil.

- (i) Oil filled cables
- (ii) Gas pressure cables

3.2.6.1. Oil filled cables

In case of oil filled cables, the channels or ducts are provided within or adjacent to the cores, through which oil under pressure is circulated.

The construction of single core oil filled cable. It consists of concentric stranded conductors but built around a hollow cylindrical steel spiral core. This hollow core acts as a channel for the oil. The oil channel is filled in a factory and the pressure is maintained in the oil by connecting the oil channel to the tanks which are placed at the suitable distances along the path of the cable.

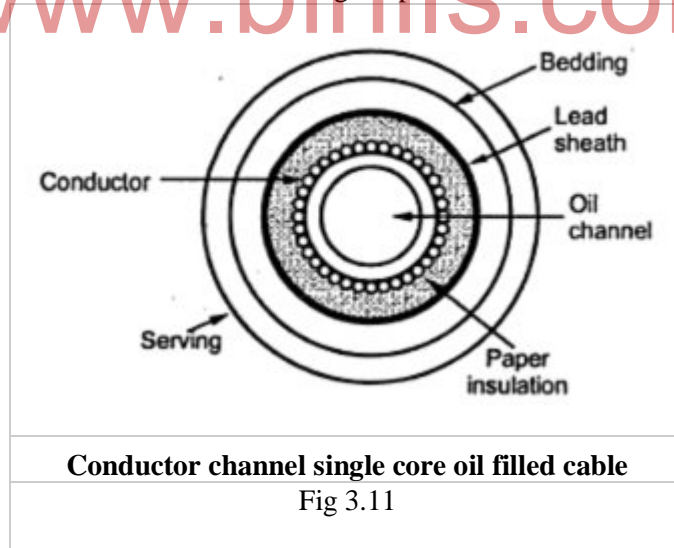

The oil pressure compresses the paper insulation, eliminating the possibility of formation of voids. When cable is heated, the oil expands but expanded oil is collected in the tank. While when cable is cooled, extra oil is supplied by the tank to maintain the oil pressure. In this type of cable the oil channel is within the conductor, hence it is called single core conductor channel oil filled cables. The other construction of the cable is similar to that of solid type cables.

Another type of single core oil filled cable is the sheath channel oil filled cable. In this type, the conductor is solid with a paper insulation. While the oil ducts are provided between the dielectric and the lead sheath.

The construction of sheath channel oil filled cable is shown in the Fig.3.12. The laying of such cables must be done very carefully.

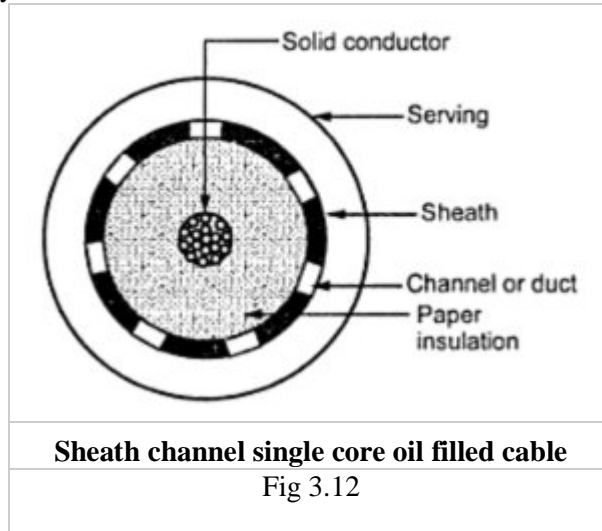

The three core oil filled cables use the shielded type construction. The oil channels are located in the spaces which are normally occupied by the filler material. The three oil channels are of preformed metal ribbon tubing. All the channels are at earth potential. The construction is shown in the Fig. 3.13. As the pressure tanks are required all along the route of these cables, the lengths of these cables are limited. Leakage of oil is another serious problem associated with these cables. Automatic signalling units are located to indicate the fall in oil pressure in any of the phases.

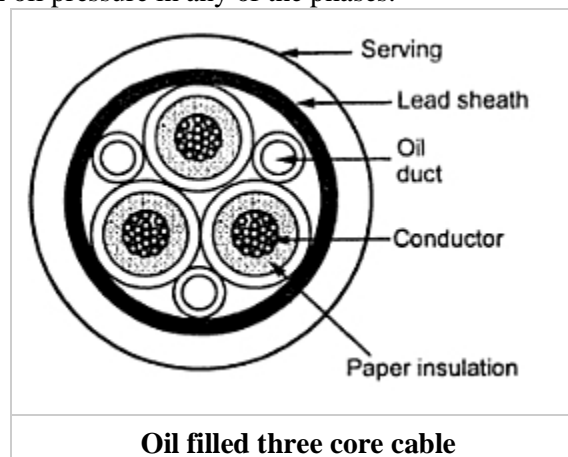

Advantages

The various advantages of oil filled cables are,

1. The thickness of insulation required is less hence smaller in size and weight.
2. The thermal resistance is less hence current carrying capacity is more.
3. The possibility of voids is completely eliminated.
4. The allowable temperature range is more than solid type cables.
5. Reduced possibility of earth fault. This is because in case of any defect in lead sheath, oil leakage starts, which can be noticed before earth fault occurs.
6. Perfect impregnation is possible.

Disadvantages

The disadvantages of oil filled cables are,

1. The initial cost is very high.
2. The long length are not possible.
3. The oil leakage is serious problem hence automatic signalling equipment is necessary.
4. The laying of cable is difficult and must be done very carefully.
5. Maintenance of the cables is also complicated.

3.2.6.2 Gas pressure cables

In case of gas pressure cables, an inert gas like nitrogen at high pressure is introduced. lead sheath and dielectric. The pressure is about 12 to 15 atmospheres. Due to such a high pressure there is a radial compression due to which the ionization is totally eliminated. The working power factors of such cables are also high.

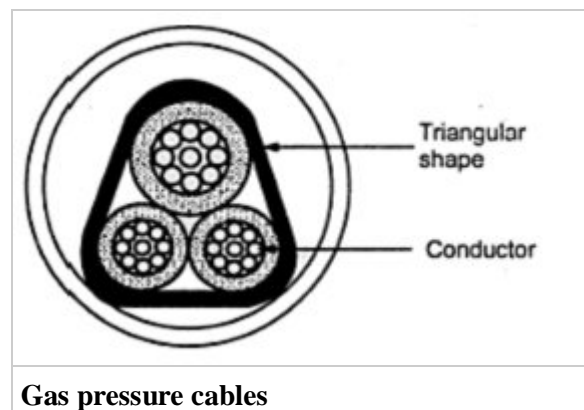

Fig 3.14

Fig 3.14 shows the section of a gas pressure cable. The cable is triangular in shape and installed in the steel pipe. The pipe is filled with the nitrogen at 12 to 15 atmospheric pressure. The remaining construction is similar to that of solid type cable but the thickness of lead sheath is 75% of that of solid type cable. There is no bedding and serving.

The triangle shape lead sheath acts as a pressure membrane. The shape reduces the weight and provides the low thermal resistance. The high pressure creates the radial compression to close any voids. The steel pipe is coated with a point to avoid corrosion. During heating, the cable compound expands and a sheath with acts as a membrane becomes circular in such a case. When cable cools down the gas pressure acting via sheath forces compound to come back to the noncircular normal shape. Due to good thermal characteristics, fire quenching property and high dielectric strength, the gas SF₆ is also used in such cables.

Advantages

The various advantages of gas pressure cables are,

1. Gas pressure cables can carry 1.5 times the normal load current and can withstand double the voltage. Hence such cables can be used for ultra high voltage (UHV) levels.
2. Maintenance cost is small.
3. The nitrogen in the steel tube, helps in quenching any fire or flame.
4. No reservoir or tanks required.
5. The power factor is improved.
6. The steel tubes used make the cable laying easy.
7. The ionization and possibility of voids is completely eliminated.

3.2.7. Laying Underground Cables

- a. Direct Laying
- b. Draw in system
- c. Solid system

3.2.7. 1. Direct laying.

This method of laying underground cables is simple and cheap and is much favoured in modern practice. In this method, a trench of about 1.5 meters deep and 45 cm wide is dug. The trench is covered with a layer of fine sand (of about 10 cm thickness) and the cable is laid over this sand bed. The sand prevents the entry of moisture from the ground and thus protects the cable from decay. After the cable has been laid in the trench, it is covered with another layer of sand of about 10 cm thickness.

The trench is then covered with bricks and other materials in order to protect the cable from mechanical injury. When more than one cable is to be laid in the same trench, a horizontal or vertical interracial spacing of at least 30 cm is provided in order to reduce the effect of mutual heating and also to ensure that a fault occurring on one cable does not damage the adjacent cable. Cables to be laid in this way must have serving of bituminized paper and hessian tape so as to provide protection against corrosion and electrolysis.

Advantages

- (i) It is a simple and less costly method.
- (ii) It gives the best conditions for dissipating the heat generated in the cables.
- (iii) It is a clean and safe method as the cable is invisible and free from external disturbances.

Disadvantages

- (i) The extension of load is possible only by a completely new excavation which may cost as much as the original work.
- (ii) The alterations in the cable network cannot be made easily.
- (iii) The maintenance cost is very high.
- (iv) Localization of fault is difficult.
- (v) It cannot be used in congested areas where excavation is expensive and inconvenient.

3.2.7. 2. Draw-in system

In this method, conduit or duct of glazed stone or cast iron or concrete are laid in the ground with manholes at suitable positions along the cable route. The cables are then pulled into position from manholes. Figure shows section through four-way underground duct line. Three of the ducts carry transmission cables and the fourth duct carries relay protection connection, pilot wires. Care must be taken that where the duct line changes direction ; depths, dips and offsets be made with a very long radius or it will be difficult to pull a large cable between the manholes. The distance between the manholes should not be too long so as to simplify the pulling in of the cables. The cables to be laid in this way need not be armored but must be provided with serving of hessian and jute in order to protect them when being pulled into the ducts.

Advantages

- (i) Repairs, alterations or additions to the cable network can be made without opening the ground.
- (ii) As the cables are not armoured, therefore, joints become simpler and maintenance cost is reduced considerably.
- (iii) There are very less chances of fault occurrence due to strong mechanical protection provided by the system.

Disadvantages

- (i) The initial cost is very high.
- (ii) The current carrying capacity of the cables is reduced due to the close grouping of cables and unfavorable conditions for dissipation of heat.

3.2.7. 3. Solid system.

In this method of lying, the cable is laid in open pipes or troughs dug out in earth along the cable route. The troughing is of cast iron, stoneware, asphalt or treated wood. After the cable is laid in position, the troughing is filled with a bituminous or asphaltic compound and covered over. Cables laid in this manner are usually plain lead covered because troughing affords good mechanical protection.

Disadvantages

- (i) It is more expensive than direct laid system.
- (ii) It requires skilled labour and favourable weather conditions.
- (iii) Due to poor heat dissipation facilities, the current carrying capacity of the cable is reduced.

3.2.8. Grading of Cable

Grading is defined as the process of equalizing the stress in the dielectric of the cable. Generally, the electrical stress is maximum at the surface of the conductor or the innermost part of conductor while it is minimum at the outermost sheath of the conductor. If the stress is equal to all the dielectric of the conductor, then the thickness of the conductor is reduced. But if the stress is maximum at any of the dielectrics then it increases the thickness of the cable due to which the cost of the cable also increases. There are two methods of grading the cable

- Capacitance Grading
- Inters heath Grading

3.2.9. Methods of Grading

3.2.9.1 Capacitance Grading or Dielectric Grading

In this type of grading, the homogeneous dielectric is replaced by layers of dielectric having a different value of relative permittivity. For getting a uniform stress, an infinite number of dielectric will be required. The electrical stress can be uniformly distributed by using two or more dielectric having suitable permittivity.

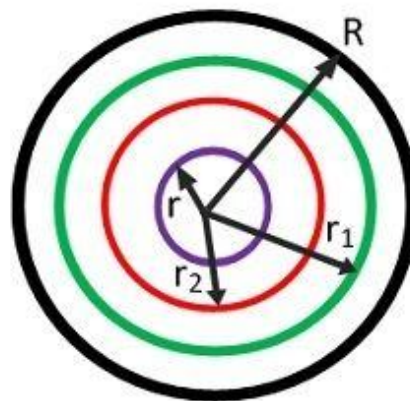

Dielectric Grading

Fig 3.16

The dielectric stress is given by the equation

Let us considered a cable having three dielectrics of relative permittivity ϵ_1 , ϵ_2 , and ϵ_3 , such that $\epsilon_1 < \epsilon_2 < \epsilon_3$. Let r_1 , r_2 and R be the outer radii of the dielectric.

The maximum stress is given by

$$g_{max1} = \frac{q}{2\pi\epsilon_0\epsilon_1r}$$

$$g_{max2} = \frac{q}{2\pi\epsilon_0\epsilon_2r}$$

$$g_{max3} = \frac{q}{2\pi\epsilon_0\epsilon_3r}$$

In case the maximum stress is the same in the each layer

$$g_{max1} = g_{max2} = g_{max3} = g_{max}$$

$$\epsilon_1r = \epsilon_2r = \epsilon_3r$$

The total voltage applied across the cable

$$V = g_{max} \left(r \ln \frac{r_1}{r} + r_1 \ln \frac{r_2}{r_1} + r_2 \ln \frac{R}{r_2} \right)$$

g_{max} represent the peak value of electrical stress, and all the voltages are represented in peak values, not in RMS value.

3.2.9.2. Intersheath Grading

Intersheath grading is the method of keeping the gradual voltage across the insulator by using the layers of the insulators. In this method, the uniform voltage is developed across the cable insulators. The total layer of the insulation material is divided into numbers of layers by providing intersheath.

Intersheaths are thin metallic cylindrical sheaths concentric with the conductor and placed between the conductor and the outside sheath. Consider a cable with one intersheath only as shown below.

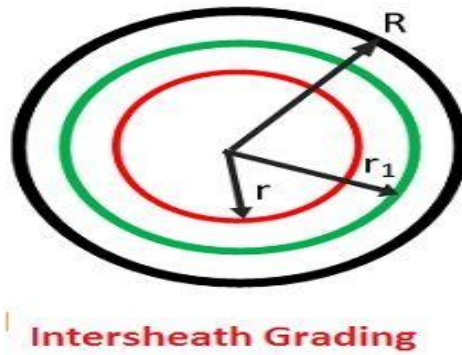

Fig 3.17

Consider a cable with one intersheath only as shown in the figure below.

Let r_1 = radius of the intersheath

R = radius of the outer sheath

V_1 = voltage between the core and the intersheath

V_2 = voltage between the intersheath and outer sheath

V = applied voltage between the core and the sheath

The maximum potential gradient in the second layer

$$r = \frac{V_1}{g_{max}} = \frac{V}{e g_{max}}$$

$$r_1 = \frac{V_1 e}{g_{max}} = \frac{V}{g_{max}}$$

$$R = \frac{V}{g_{max}} e^{1 - \frac{1}{e}}$$

$$R = 1.881 \frac{V}{g_{max}}$$

Limitations of Grading

- **Capacitance grading**

The main disadvantage of the capacitance grading is that the range of permittivity value of insulating material available for cable insulation is limited. The permittivity of the layers may not remain

constant thereby change the stress distribution and cause the insulation break down at normal operating condition.

- **Intersheath grading**

In Intersheath grading, the intersheath layers are very thin and are liable to be damaged during transportation or installation. Also, thin intersheath are not able to carry the damage charging current of long cable line and thus the current-carrying capacity of the cable is reduced. For these reasons the present trends is to avoid grading

3.2.10. Faults in Cables

Distribution of the electrical energy is done via electrical cables. The cables are either insulated or uninsulated. The choice of using insulated or uninsulated (Overhead lines or Underground) cables mostly come into play when energy is to be conveyed in the underground installation process.

Unlike the insulated cables, faults in uninsulated cables are easily detected as the most common fault associated with such type of cable is cut and break in the cable or wire conductors.

In insulated cables especially the multicore cables, the faults are of different types and have many causes.

3.2.11. Types of Cable Faults

Following are the types of **Cable Faults** Commonly Found In the underground Cables.

- **Open-Circuit Faults:** Open circuit fault is a kind of fault that occurs as a result of the conductor breaking or the conductor being pulled out of its joint. In such instances, there will be no flow of current at all as the conductor is broken (conveyor of electric current).
- **Short-circuit or cross fault:** This kind of fault occurs when the insulation between two cables or between two multi-core cables gets damaged. In such instances, the current will not flow through the main core which is connected to load but will flow directly from one cable to another or from one core or multi-core cable to the other instead. The load will be short circuited.
- **Ground or earth faults:** This kind of faults occurs when the insulation of the cable gets damaged. The current flowing through the faulty cable starts flowing from the core of the cable to earth or the sheath (cable protector) of the cable. Current will not flow through the load then.

Causes of Cable Faults

- Faults in cables are mostly caused by dampness in the paper insulation of cables. As a result, it may damage the lead sheath which protecting the cable.
- Lead sheath can be damaged in many ways. Most of them are the chemical action of soil on the lead when buried, mechanical damage and crystallization of the lead through vibration.

Loop Tests to finding Cable faults

Cable faults can be easily located if a sound cable runs along with the grounded cables. These

kinds of tests are carried out on short circuit faults or earth fault in underground cables. Following are the types of loop tests.

- **Murray loop Test**
- **Varley loop Test.**
- **Earth Overlap Test**

Murray Loop Test

This test is used to find the fault location in an underground cable by making one Wheatstone Bridge in it and by comparing the resistance we shall find out the fault location. But we should use the known length of the cables in this experiment. The necessary connection of the Murray loop test is shown in figures. The figure 3.18 (i) shows that the circuit connection for finding the fault location when the ground fault occurs and the figure 3.18(ii) shows that the circuit connections for finding the fault location when the short circuit fault occurs.

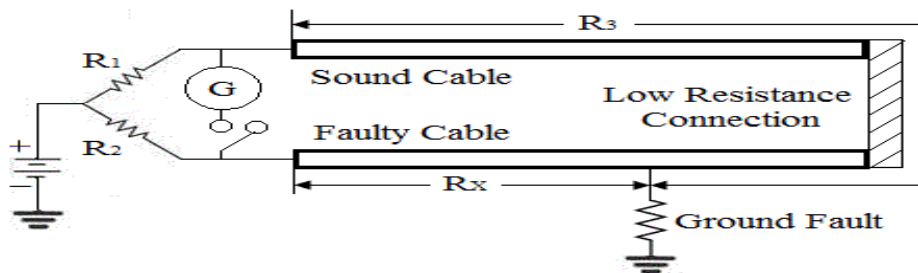

Fig.2. Circuit connection of Murray loop test for ground fault

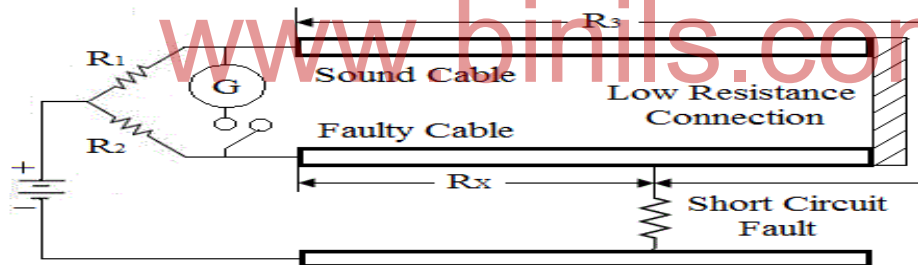

Fig.3. Circuit connection of Murray loop test for short circuit fault

Fig 3.18 (i)&(ii)

In this test, the faulty cable is connected with sound cable by a low resistance wire, because that resistance should not affect the total resistance of the cable and it should be able to circulate the loop current to the bridge circuits without loss.

The variable resistors R_1 and R_2 are forming the ratio arms. Balance of the bridge is achieved by adjusting the variable resistors. 'G' is the galvanometer to indicate the balance. $[R_3 + R_x]$ is the total loop resistance formed by the sound cable and the faulty cable. At the balance condition,

$$\frac{R_1}{R_2} = \frac{R_3}{R_X} \Rightarrow \frac{R_1 + R_2}{R_2} = \frac{R_3 + R_X}{R_X}$$

$$\Rightarrow R_X = \frac{R_2}{R_1 + R_2}(R_3 + R_X)$$

When the cross section area of the both sound cable and faulty cable are equal, then the resistance of the conductors are directly proportional to their lengths. So, if L_X represents the length between test end to the fault end of the faulty cable and if L represents the total length of the both cables, then the expression for L_X is as follows;

$$L_X = \frac{R_2}{R_1 + R_2}L$$

The above test is only valid when the lengths of the cables are known. In Murray Loop Test, the fault resistance is fixed and it may not be varied. Also it is difficult to set the bridge as balance. Thus, the determination of the fault position is not accurate. Then the current circulation through the cable would cause temperature rises due to high voltage or high current. If the resistance varies according to the temperature, then the balance collapses. So, we need to apply less voltage or less current to this circuit.

www.binils.com

REVIEW QUESTION

2MARKS & 3MARKS

1. What are the different types of insulators?
2. What are the materials used for manufacturing insulators?
3. State the classification of cables based on voltage.
4. What is meant by grading of cables?
5. Name the types of pressure cable.
6. What are the tests adopted in insulator?
7. State the cables used for 3 phase services.
8. What are the fault occur in cables.
9. What is the purpose of insulator?
10. What is string efficiency?
11. Name the types of grading of cables.
12. State the reason for failure of insulators.

10 MARKS

1. Explain the causes of failure of insulator.
2. Define string efficiency for insulator.
3. Explain impulse frequency flash over test on insulator.
4. List the advantage of suspension insulator.
5. State the properties required for the insulating material. List the advantage of U.G cables.
6. What are the advantage and disadvantage of filled cables?
7. Explain capacitance grading of U.G cables.
8. Explain the various method of testing of insulators.
9. Write about grading of cables.
10. Explain the various method of testing of cables.
11. How to improve the string efficiency of the suspension insulator?
12. Hoe to equalize the voltage across the suspension type insulator?
13. Explain different type of laying cables.
14. Explain various parts of three conductor UG cables.
15. Explain with neat sketch any two types of insulators.

UNIT IV

CIRCUIT BREAKERS AND OVER VOLTAGE PROTECTION

4. SWITCHGEAR

In an electric power system, **switchgear** is the combination of electrical switches, fuses or circuit breakers used to control, protect and isolate electrical equipment. Switchgears are used both to de-energize equipment from the working condition and to clear faults downstream. This type of equipment is directly linked to the reliability of the electricity supply.

The apparatus used for switching, controlling and protecting the electrical circuits and equipment is known as switchgear.

The term 'switchgear' is a generic term encompassing a wide range of products like circuit breakers, switches, switch fuse units, off-load isolators, HRC fuses, contactors, earth leakage circuit breakers (ELCBs), etc...

4.1 Essential features of Switch gear

The essential features of switchgear are:

1. **Complete reliability:**

With the continued trend of interconnection and the increasing capacity of generating stations, the need for reliable switchgear has become of paramount importance. This is not surprising because switchgear is added to the power system to improve the reliability. When fault occurs on any part of the power system, the switchgear must operate to isolate the faulty section from the remainder circuit.

2. **Absolutely certain discrimination:**

When fault occurs on any section of the power system, the switchgear must be able to discriminate between the faulty section and the healthy section. It should isolate the faulty section from the system without affecting the healthy section. This will ensure continuity of supply.

3. **Quick operation:**

When fault occurs on any part of the power system, the switchgear must operate quickly so that no damage is done to generators, transformers and other equipment by the short-circuit currents. If fault is not cleared by switchgear quickly, it is likely to spread into healthy parts, thus endangering complete shutdown of the system

4. **Provision for manual control:**

Switchgear must have provision for manual control. In case the electrical (or electronics) control fails, the necessary operation can be carried out through manual control.

4.2 Faults in a Power system

Definition:

Fault in electrical equipment or apparatus is defined as an imperfection in the electrical circuit due to which current is deflected from the intended path. In other words, the fault is the abnormal

condition of the electrical system which damages the electrical equipment and disturbs the normal flow of the electric current.

4.2.1 Types of Electrical Fault

The most common and dangerous fault that occurs in a power system is the short circuit or shunt fault. On the occurrence of the short circuit fault, heavy or short-circuit current flow through the circuit which damages the insulation of current carrying phase conductors corresponding to earth or in the insulation between phases. The different types of the electrical fault are explained below:

1. **Single Phase to Ground Fault** – It is also called a line-to-ground fault. It mainly occurs due to insulation breakdown between one of the phase and earth. Single-line-to-fault is most frequently occurs in the power system. Their chances of appearance in the power system are 70%.
2. **Phase-to-Phase Fault** – Such type of fault rarely occurred on the power system. It is also called Line-to-line fault. It occurs when two conductors are short circuited. Their chance of appearance is hardly 15 % in the power system.
3. **Two Phases to Ground Fault** – In this type of fault breakdowns of insulation between two phases and earth occur. It is the most severe type of fault but rarely occurs in the power system. It is also called Line-to-line-to-ground fault (L-L-G). Their chance of occurrence is hardly 10 %.
4. **Phase to phase and Third Phase to Ground Fault** – It is the combination of phase to phase and phase to phase to ground fault. Such types of fault occur due to the breakdown of insulation between two phases and simultaneous breakdown of insulation between the third phase and earth. The chance of such type of fault is hardly 2 % to 3 %.
5. **All the Three Phases to Ground Fault** – It is the most severe type of the fault and very rarely occurs in the power system. It occurs due to a breakdown of insulation between all the phases as well as to the earth. It is 2% to 3% in the power system.
6. **All the three Phases Short Circuited** – This type of fault mainly occurs due to a breakdown of insulation between all the three phases. Their appearance is rarely 2 % to 3% in the power system.

The first four faults are of an unsymmetrical nature and occurs to unsymmetrical current, i.e., different currents in the three phases. The last two faults are of symmetrical nature and occurs to symmetrical current, i.e., equal fault current in all the three phases with 120° displacement.

4.3 Circuit Breakers

A circuit breaker essentially consists of fixed and moving contacts, called electrodes. Under normal operating conditions, these contacts remain closed and will not open automatically until and unless the system becomes faulty.

The contacts can be opened manually or by remote control whenever desired. When a fault occurs on any part of the system, the trip coils of the breaker get energised and the moving contacts are pulled apart by some mechanism, thus opening the circuit.

Operating principle of Circuit Breaker

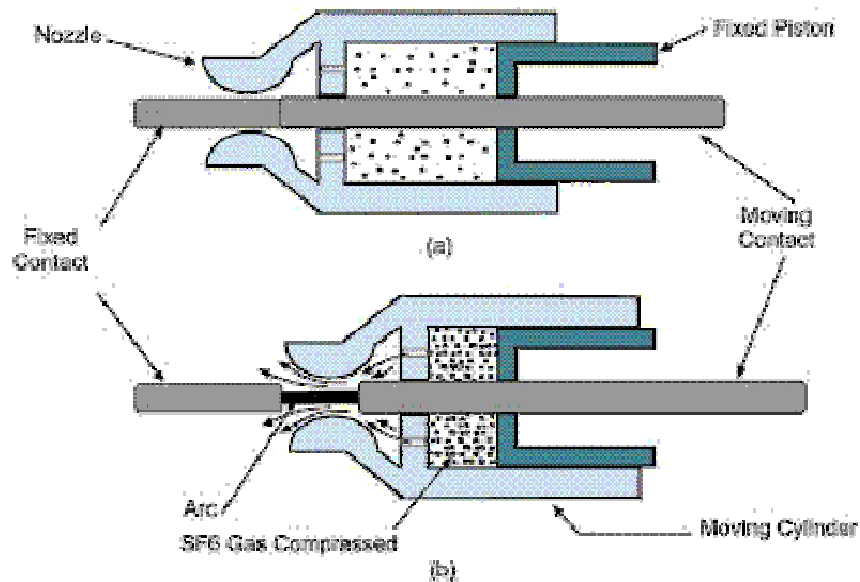

Fig 4.1

When the contacts of a circuit breaker are separated under fault conditions, an arc is struck between them. The current is thus able to continue until the discharge ceases. The production of arc not only delays the current interruption process but it also generates enormous heat which may cause damage to the system or to the breaker itself. Therefore, the main problem in a circuit breaker is to extinguish the arc within the shortest possible time so that heat generated by it may not reach a dangerous value.

4.3.1 Arc Phenomenon in Circuit Breaker

When a short-circuit occurs, a heavy current flows through the contacts of the circuit breaker before they are opened by the protective system. At the instant when the contacts begin to separate the contact area decreases rapidly and large fault current causes increased current density and hence rise in temperature.

The heat produced in the medium between contacts (usually the medium is oil or air) is sufficient to ionize the air or vaporize and ionize the oil. The ionized air or vapor, acts as conductor and an arc is struck between the contacts. The potential difference between the contacts is quite small and is just sufficient to maintain the arc. The arc provides a low resistance path and consequently the current in the circuit remains uninterrupted so long as the arc persists.

During the arcing period, the current flowing between the contacts depends upon the arc resistance. The greater the arc resistance, the smaller the current that flows between the contacts. The arc resistance depends upon the following factors:

1. **Degree of ionization** - the arc resistance increases with the decrease in the number of ionised particles between the contacts.
2. **Length of the arc** - the arc resistance increases with the length of the arc i.e. separation of contacts.

3. **Cross section of arc** - the arc resistance increase with the decrease in the area of cross section of the arc.

4.4 METHODS OF ARC EXTINCTION

There are two methods of extinguishing the arc in circuit breakers

1. High resistance method
2. Low resistance or current zero method.

1. High Resistance Method

In this method, arc resistance is made to increase with time so that current is reduced to a value insufficient to maintain the arc. Consequently, the current is interrupted or the arc is extinguished.

The principal disadvantage of this method is that enormous energy is dissipated in the arc. Therefore, it is employed only in d.c. circuit breakers and low-capacity a.c. circuit breakers.

The resistance of the arc may be increased by

- *Lengthening the arc* - The resistance of the arc is directly proportional to its length. The length of the arc can be increased by increasing the gap between contacts.
- *Cooling the arc* - Cooling helps in medium between the contacts. This increases the arc may be obtained by a gas resistance. Efficient cooling blast directed along the arc.
- *Reducing cross-section of the arc* - If the area of cross-section of the arc is reduced, the voltage necessary to maintain the arc is increased. In other words, the resistance of the arc path is increased. The cross-section of the arc can be reduced by letting the arc pass through a narrow opening or by having smaller area of contacts.
- *Splitting the arc* - The resistance of the arc can be increased by splitting the arc into a number of smaller arcs in series. Each one of these arcs experiences the effect of lengthening and cooling. The arc may be split by introducing some conducting plates between the contacts.

2. Low Resistance or Current zero Method

This method is employed for arc extinction in AC Circuits only.

In this method, arc resistance is kept low until current zero where the arc extinguishes naturally and is prevented from restriking in spite of the rising voltage across the contacts.

All modern high power AC Circuit Breakers employ this method for arc extinction.

In an a.c. system, current drops to zero after every half-cycle. At every current zero, the arc extinguishes for a brief moment.

Now the medium between the contacts contains ions and electrons so that it has small dielectric strength and can be easily broken down by the rising contact voltage known as restriking voltage.

If such a break-down does occur, the arc will persist for another half-cycle. If immediately after current zero, the dielectric strength of the medium between contacts is built up more rapidly than the voltage

across the contacts, the arc fails to restrike and the current will be interrupted. The rapid increase of dielectric strength of the medium near current zero can be achieved by

- (a) Causing the ionised particles in the space between contacts to recombine into neutral molecules.
- (b) Sweeping the ionised particles away and replacing them by unionised particles.

Therefore, the real problem in AC arc interruption is to rapidly deionise the medium between contacts as soon as the current becomes zero so that the rising contact voltage or restriking voltage cannot breakdown the space between contacts. The de-ionization of the medium can be achieved by :

(i) Lengthening of the gap :

The dielectric strength of the medium is proportional to the length of the gap between contacts. Therefore, by opening the contacts rapidly, higher dielectric strength of the medium can be achieved.

(ii) High pressure.

If the pressure in the vicinity of the arc, is increased, the density of the particles constituting the discharge also increases. The increased density of particles causes higher rate of de-ionisation and consequently the dielectric strength of the medium between contacts is increased.

(iii) Cooling:

Natural combination of ionised particles takes place more rapidly if they are allowed to cool. Therefore, dielectric strength of the medium between the contacts can be increased by cooling the arc

(iv) Blast effect :

If the ionised particles between the contacts are swept away and replaced by un-ionised particles, the dielectric strength of the medium can be increased considerably. This may be achieved by a gas blast directed along the discharge or by forcing oil into the contact space.

Restriking voltage:

It may be defined as the voltage that appears across the breaking contact at the instant of arc extinction.

Recovery voltage:

It may be defined as the voltage that appears across the breaker contact after the complete removal of transient oscillations and final extinction of arc has resulted in all the poles.

Active recovery voltage:

It may be defined as the instantaneous recovery voltage at the instant of arc extinction.

Arc voltage:

It may be defined as the voltage that appears across the contact during the arcing period, when the current flow is maintained in the form of an arc. It assumes low value except for the point at which the voltage rise rapidly to a peak value and current reaches to zero.

The rate of Rise of Restriking Voltage –

It is defined as the slope of the steepness tangent of the restriking voltage curve. It is expressed in $KV/\mu s$. RRRV is directly proportional to the natural frequency. The expression for the restriking voltage is expressed as

$$RRRV_{max} = \frac{V_{max}}{\sqrt{LC}}$$

The transient voltage vanishes rapidly due to the damping effect of system resistance, and the normal frequency system voltage is established. This voltage across the breakers contact is called recovery voltage.

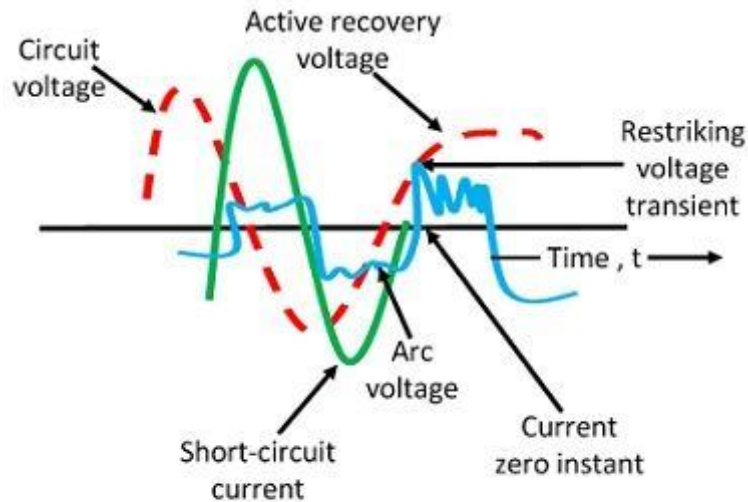

Arc Extinction
www.binils.com
Fig 4.2

The waveforms of recovery and the restriking voltage are shown in the figure 4.2. After the current zero, the voltage appearing across the breaker contacts is composed of transient restriking voltage and power frequency recovery voltage.

4.5 Current chopping

While interrupting highly inductive current, like no-load current of transformer, the rapid deionization of contact space and blast effect may cause current interruption before its natural zero. Such an' interruption of current before its natural zero is termed as “**current chopping**”. This phenomenon is more pronounced in case of air-blast circuit breakers which exerts the same demonizing force for all currents within its short-circuit capacity. Even though, the instantaneous value of current being interrupted may be less than the normal current rating of the breaker, it is quite dangerous from the point of view of overvoltages which may result in the system.

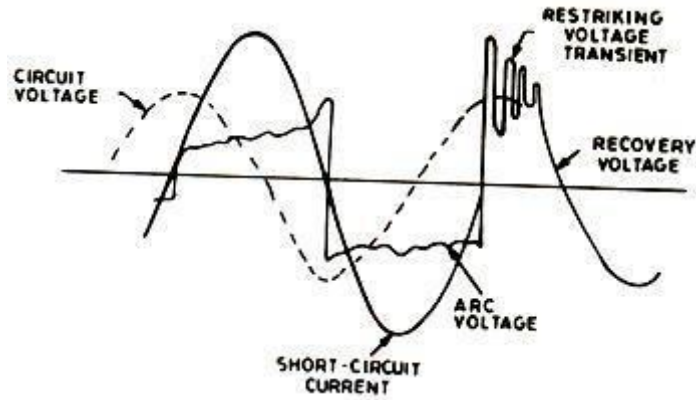

Fig 4.3

Let,

L = Inductance of the system

C = Capacitance of the system

i = Instantaneous value of arc current

V = Instantaneous value of capacitor voltage (which appears across the breaker when it opens)

The electromagnetic energy stored in the system at the instant before interruption is $\frac{1}{2}(Li^2)$. As soon as the current is interrupted the value of i becomes zero. But, the electromagnetic energy stored in the system $[\frac{1}{2}(Li^2)]$ cannot become zero instantaneously and so it is converted into electrostatic energy $[\frac{1}{2}(CV^2)]$ as the system has some capacitance.

www.binils.com

According to the principle of energy conversion we have,

$$\frac{1}{2}(Li^2) = \frac{1}{2}(CV^2)$$

$$V = i\sqrt{L/C}$$

This theoretical value of V is called as “**prospective Voltage or Arc Voltage**”. If this voltage is very high when compared with the gap withstanding voltage, then the gap breakdowns and so the arc restrikes. Again the current is chopped (interrupted) because of high quenching force and so, restriking occurs. This process repeats until the current is suppressed finally without any restrike and this occurs near current zero as shown in the figure 4.3.

In actual practice the voltage across the breaker does not reach dangerously high prospective values of voltage. It is due to the fact that as soon as the breaker voltage increases beyond the gap withstanding voltage, it breaks down and the arc restrikes due to which the voltage across breaker falls to a very low value of arc voltage which can also be seen in the figure. Hence, it can be said that the arc is not an undesirable phenomenon and instead it protects the power system from severe stress on insulation due to overvoltages.

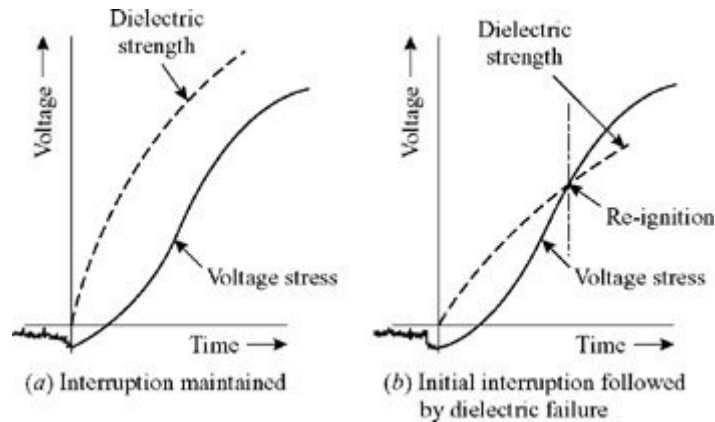

Fig 4.4

In order to reduce the **phenomenon of current chopping**, the overvoltage are to be reduced. This is possible by connecting voltage— grading (or non-linear) resistors across the circuit breaker contacts during arc interruption. In medium voltage systems, an RC surge absorber is connected across line and ground in between the inductive load and the circuit breaker. As a result, the RC combination absorbs the overvoltages.

Capacitive current breaking.

Another cause of excessive voltage surges in the circuit breakers is the interruption of capacitive currents. Examples of such instances are opening of an unloaded long transmission line, disconnecting a capacitor bank used for power factor improvement etc.

4.6 Resistance Switching

A fixed connection of resistance in parallel with the contact space or arc is called the resistance switching. Resistance switching is employed in circuit breakers having a high post zero resistance of contact space.

Severe voltage occurs in the system because of two reasons, firstly because of the breaking of low voltage current, and secondly because of the breaking of capacitive current. This may endanger the operation of the system. This can be avoided by using resistance switching (by connecting the resistor across the contacts of the circuit breaker).

When the fault occurs, the contacts of the circuit breaker are open, and an arc is struck between the contacts. With the arc shunted by the resistance **R**, a part of arc current is diverted through the resistance. This results in the decreases of arc current and an increase in the rate of deionization of the arc path.

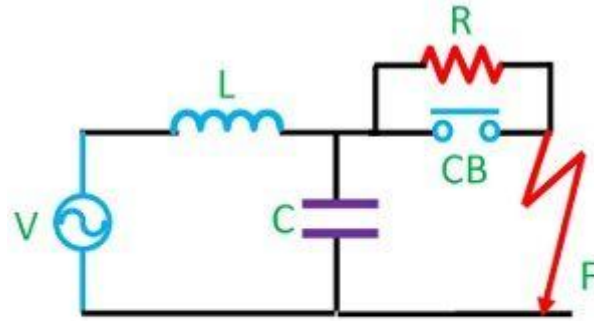

Resistance Switching Circuit

Circuit Globe

Fig 4.5

Thus, the arc resistance is increased, leading to the further increase in current through the shunt resistance **R**. This builds up process continue until the current becomes so small that it fails to maintain the arc shown in the figure 4.6. Now the arc is extinguished, and the circuit breaker gets interrupted.

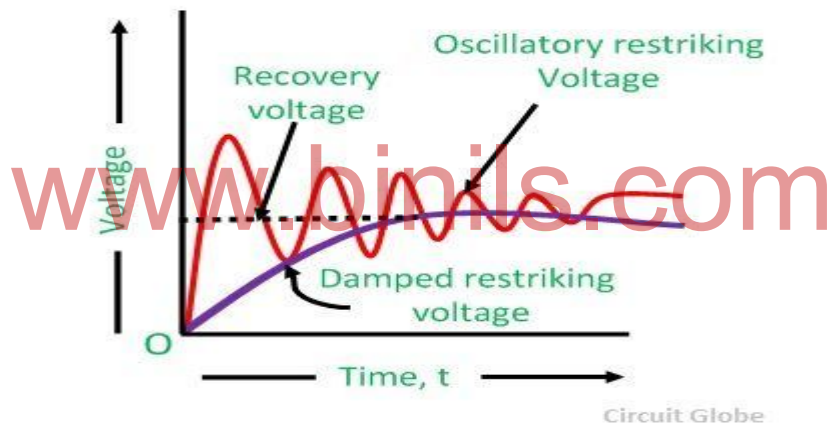

Fig 4.6

Alternatively, the resistance may be automatically switched in by transference of the arc from the main contacts to the probe contact as in the case of an axial blast circuit breaker, the time required for this action is very small. Having the arc path substituted by a metallic path, the current flowing through the resistance is limited and then easily broken.

4.7 Circuit Breaker Ratings

The rating of circuit breaker is given according to the duties that are performed by it. For complete specifications, standard rating and various tests of switches and circuit breakers IS 375/1951 may be consulted. A circuit breaker is required to perform the following three major duties.

It must be capable of opening the faulty circuit and breaking the fault current. This is described as breaking capacity of a circuit breaker

1. It must be capable of being closed on to a fault. This refers to making capacity of a circuit breaker

2. It must be capable of carrying fault current for a short time while another circuit breaker is clearing the fault. This refers to short time capacity of the circuit breaker.

In addition to the above ratings, a circuit breaker should be specified in terms of

- **Rated voltage:**
The rated maximum voltage of a circuit breaker is the highest rms voltage, above nominal system voltage, for which circuit breaker is designed and is the upper limit for operation. The rated voltage is expressed in kVrms and refers phase to phase voltage for three phase circuit.
- **Rated current:**
The rated normal current of a circuit breaker is the rms value of the current which the circuit breaker shall be able to carry at rated frequency and at the rated voltage continuously, under specified condition.
- **Rated frequency:**
The rated frequency of a circuit breaker is the frequency at which it is designed to operate.
- **Operating Duty:**
The operating duty of a circuit breaker consists of the prescribed number of unit operations at stated intervals.

Breaking capacity:

Breaking current is the RMS value of current that a circuit breaker is required to break at the instant of contact separation. The symmetrical breaking current is the RMS value of its symmetrical component. If however, at the instant of contact separation, the wave is still asymmetrical it is known as the asymmetrical breaking current.

Breaking capacity (MVA) = Rated symmetrical breaking current (kA) × Rated service voltage (kV) × $\sqrt{3}$

Making capacity:

A circuit breaker may complete a full short circuit on being closed. This is known as making capacity.

Making capacity = $1.8 \times \sqrt{2} \times$ Symmetrical breaking capacity.

Short time rating:

Circuit breaker should be capable of carrying high currents safely and without showing undue stress for a specified short period in a closed position. This is known as short time rating.

This happens in case of momentary fault like bird age on the transmission lines and the fault is automatically cleared and persists only for 1 or 2 seconds. For this reason the circuit breakers are short time rated and they trip only when the fault persists for a duration longer than the specified time limit.

Other Factors

Generally the fault current at various voltage levels expected are standardized while manufacturing a circuit breaker, considering the hike in fault currents in future due to adding of different sources. The voltage level and expected fault current are given below.

220kV	40kA
110kV	31.5kA
66kV	
11kV	250MVA
433V	25MVA
240V	5MVA



The various types of circuit breakers are Bulk oil circuit breakers (BOCB), Minimum oil circuit breakers (MOCB), Air blast circuit breakers (ABCB), Vacuum circuit breakers (VCB), SF₆ gas circuit breakers etc.

SF₆ CBs and VCBs are superior in performance compared with other types and hence selected for this particular sub station design for 220 & 110 KV side and 11 KV side respectively.

Breaking capacity

Breaking capacity of the circuit breaker refers to the maximum current in rms value the circuit breaker can interrupt. This is also in the order of kA.

The making capacity of the circuit breaker is usually greater than the breaking capacity of a circuit breaker as breaking an electric circuit is difficult due to arcing which occurs and which has to be quenched.

Making capacity

Making capacity of a circuit breaker is the maximum current which the breaker can conduct at the instant of closing. The making capacity is considered to the peak value of the first cycle when there is an imaginary short circuit between the phases.

When there is a short circuit in the line and the breaker is closed, the peak value of the first cycle is the most severe from an electrodynamic perspective. This value is in kA. The making capacity is expressed as a peak value as the dc offset during fault conditions is taken into account.

Auto reclosing in circuit Breakers

In electric power distribution, a **recloser**, or **autorecloser**, is a circuit breaker equipped with a mechanism that can automatically close the breaker after it has been opened due to a fault. Reclosers are used on overhead distribution systems to detect and interrupt momentary faults. Since many short-circuits on overhead lines clear themselves, a recloser improves service continuity by automatically restoring power to the line after a momentary fault.

4.7 What is a Circuit Breaker?

Electrical circuit breaker is a switching device which can be operated automatically or manually for protecting and controlling of electrical power system.

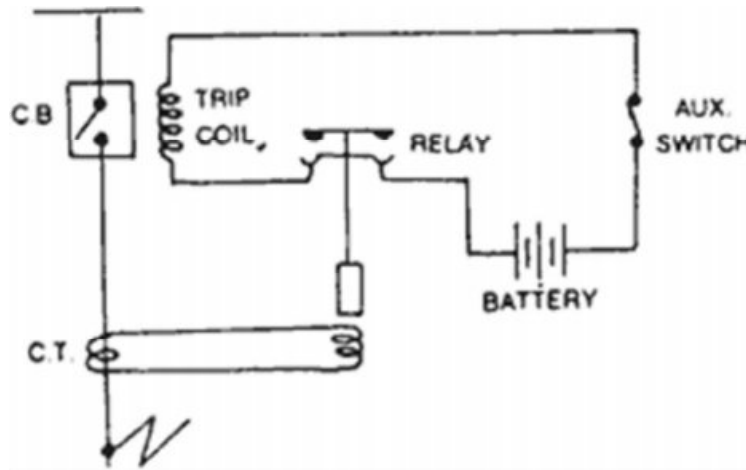

Fig 4.7 Circuit Breaker

Electricity which is coming to the houses or offices or schools or industries or to any other places from the power distribution grids forms a large circuit. Those lines which are connected to the power plant forming at one end is called the hot wire and the other lines connecting to ground forming other end. Whenever the electrical charge flows between these two lines it develops potential across them. For the complete circuit the connection of loads (appliances) offers resistance to the flow of charge and the whole electrical system inside the house or industries will work smoothly.

They work smoothly as long as the appliances have sufficiently resistant and do not cause any over current or voltage. The reasons for heating up the wires are too much charge flowing through the circuit or short circuiting or sudden connection of the hot end wire to the ground wire would heat up the wires, causing fire. The circuit breaker will prevent such situations which simply cut off the remaining circuit.

4.8 Different Types of Circuit Breakers

The different types of high voltage circuit breakers which includes the following

- Air Circuit Breaker
- SF₆ Circuit Breaker
- Vacuum Circuit Breaker
- Oil Circuit Breaker

4.9 Oil Circuit Breaker

Oil circuit breaker is such type of circuit breaker which used oil as a dielectric or insulating medium for arc extinction. In oil circuit breaker the contacts of the breaker are made to separate within an insulating oil. When the fault occurs in the system the contacts of the circuit breaker are open under the insulating oil, and an arc is developed between them and the heat of the arc is evaporated in the surrounding oil. The oil circuit breaker is divided into two categories

- Bulk Oil Circuit Breaker
- Low Oil Circuit Breaker/Minimum oil circuit breaker

Construction of Oil Circuit Breaker

Oil circuit breaker is very easy in construction. It consists of current carrying contacts enclosed in a strong, weather-tight earth metal tank and the tank is filled with transformer oil. The oil is both acts as an arc extinguishing medium and as an insulator between the live part and earth.

At the top of the oil, air is filled in the tank which acts as a cushion to control the displaced oil on the formation of gas around the arc and also to absorb the mechanical shock of the upward movement of oil. The breaker tank is securely bolted for carrying out the vibration caused on interrupting very high current. Oil circuit breaker consists gas outlet which is fitted in the tank cover for the removal of the gases.

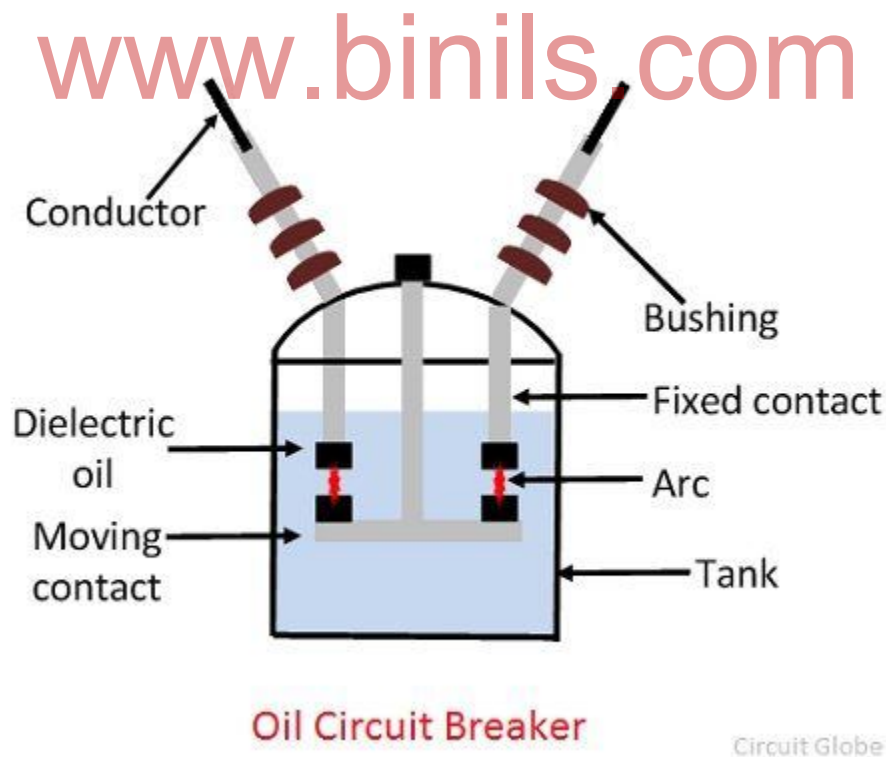

Fig 4.8

Working Principle of Oil Circuit Breaker

During the normal operating conditions, the contact of the oil circuit breaker is closed and carries the current. When the fault occurs in the system, the contacts of the breaker are moving apart, and an arc is struck between the contacts.

Due to this arc, a large amount of heat is liberated, and a very high temperature is reached which vaporises the surrounding oil into gas. The gas, thus liberated surrounds the arc and its explosive growth around it displace the oil violently. The arc is extinguished when the distance between the fixed and moving contact reaches a certain critical value, depends on the arc current and recovery voltage.

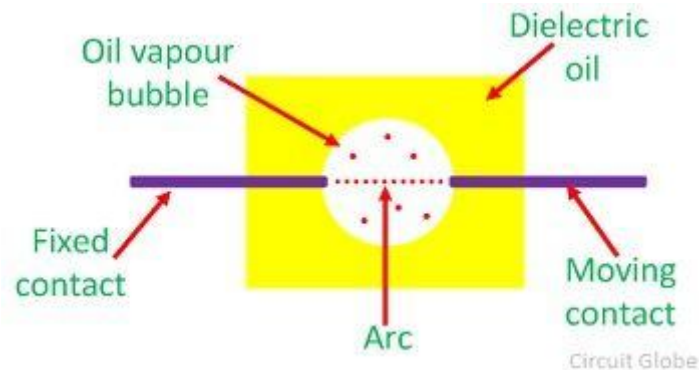

Fig 4.9

The oil circuit breaker is very reliable in operation, and it is very cheap. The most important feature of oil circuit breaker is that no special devices are used for controlling the arc caused by moving contact. The oil as an arc quenching medium has certain advantages and disadvantages

Advantages of Oil as an Arc Quenching

1. The oil has a high dielectric strength and provides insulation between the contact after the arc has been extinguished.
2. The oil used in circuit breaker provides a small clearance between the conductors and the earth components.
3. The hydrogen gas is formed in the tank which has a high diffusion rate and good cooling properties.

Disadvantages of Oil as an Arc Quenching

1. The oil used in oil circuit breaker is inflammable and hence, cause a fire hazard.
2. There is a risk of formation of explosive mixture with air.
3. Due to decomposition of oil in the arc, the carbon particles is generated which polluted the oil and hence the dielectric strength of the oil decreases.

Maintenance of oil circuit breaker

After a circuit breaker has interrupted by short-circuit current, sometimes their contacts may get burnt due to arcing. Also, the dielectric oil gets carbonized in the area of the contacts, thereby losing its dielectric strength. This results in the reduced breaking capacity of the breaker. Therefore, the maintenance of oil circuit breaker is essential for checking and replacement of oil and contacts.

4.10 Bulk Oil Circuit Breaker (BOCB)

In the BOCB, oil is used to arc the quenching media and also for insulating media in between earth parts of circuit breaker and current carrying contacts. The same transformer insulating oil is used.

The working principle of the BOCB says when the current carrying contacts in the oil are separated, then an arc is generated between the separated contacts. The arc which is established will produce rapid growing gas bubble around the arc. The moving contacts will move away from the fixed contact of arc and this result the resistance of the arc gets increased. Here the increased resistance will cause the lowering the temperature. Hence the reduced formations of gasses surround the arc.

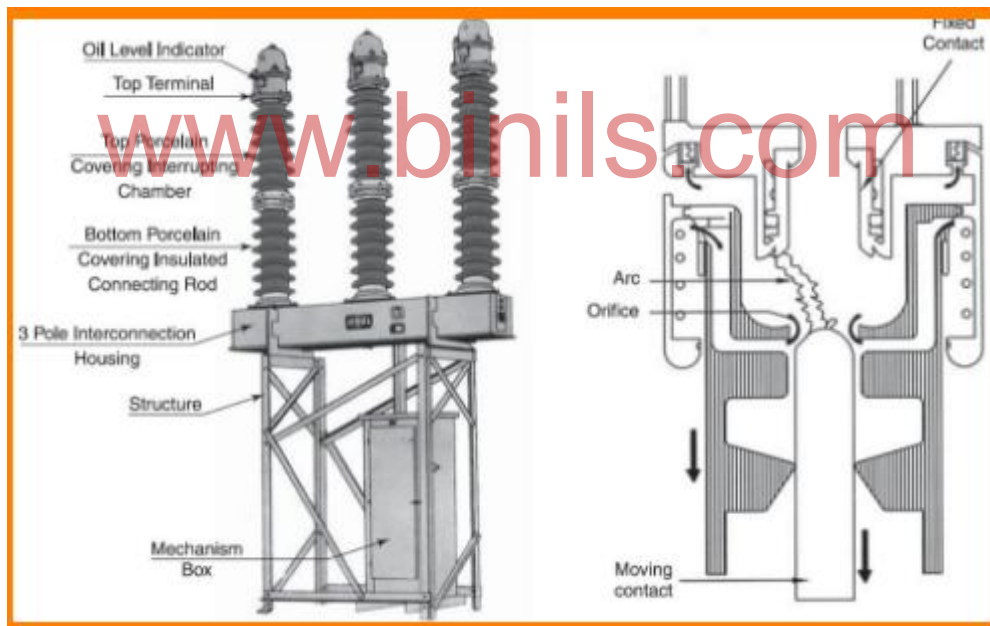

Fig 4.10 BOCB Circuit Breaker

When the current passes through zero crossing the arc quenching in the BOCB takes places. In the totally air tight vessel, the gas bubble is enclosed inside the oil. The oil will surround with high pressure on the bubble, this results in highly compressed gas around the arc. When the pressure is increased the de- ionization of the gas also increases, which results in arc quenching. The hydrogen gas will help in cooling the arc quenching in the oil circuit breaker.

Advantages

- Good cooling property because of decomposition
- Oil has high dielectric strength
- It acts like an insulator between earth and live parts.
- The oil used here will absorb arc energy while decomposing

Disadvantages

- It will not permit high speed of interruption
- It takes long arcing time.

4.11 Minimum Oil Circuit Breaker

It is a circuit breaker which utilizes oil as the interrupting media. The minimum oil circuit breaker will place the interrupting unit in an insulating chamber at the live potential. But insulating material is available in interrupting chamber. It requires less amount of oil so it is called as minimum oil circuit breaker.

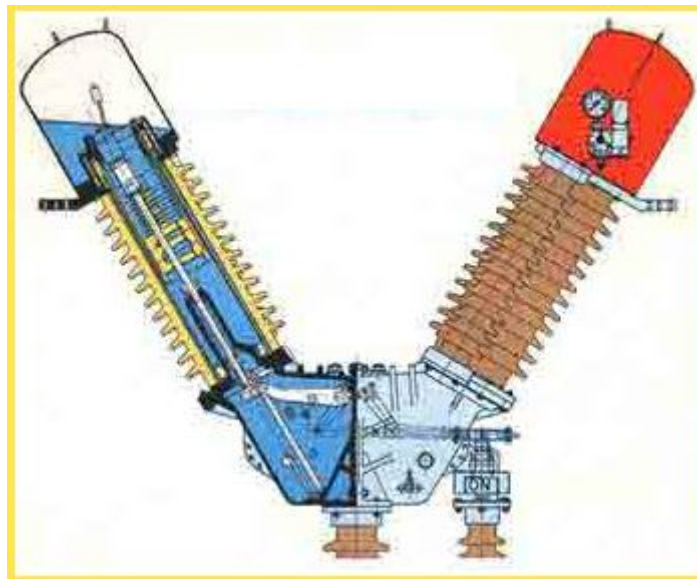

Fig 4.11 Minimum Oil Circuit Breaker

Advantages

- It requires less maintenance.

- It is suitable for both automatic operation and manual.
- It requires smaller space
- The cost for breaking capacity in MVA is also less.

Disadvantages

- Oil deteriorates because of carbonization.
- There is a possibility of explosion and fire
- As it has a smaller quantity of oil, so carbonization increases.
- It is very difficult to remove gases from the space between the contacts.

4.12 Air Blast Circuit Breaker

Air blast circuit breaker used compressed air or gas as the arc interrupting medium. In the air blast, circuit breaker compressed air is stored in a tank and released through a nozzle to produce a high-velocity jet; this is used to extinguish the arc. Air blast circuit breakers are used for indoor services in the medium high voltage field and medium rupturing capacity. Generally it is used up to voltages of 15 KV and rupturing capacities of 2500 MVA. The air blast circuit breaker is now employed in high voltage circuits in the outdoors switch yard for 220 KV lines.

Though gasses such as carbon dioxide, nitrogen, freon or hydrogen are used as the arc interrupting medium, compressed air is the accepted circuit breaking medium for gas blast circuit breakers. The reasons are given below.

The circuit breaking capacities of nitrogen are similar to compressed air and hence no advantage of using it. Carbon dioxide has the drawback of its being difficult to control owing to freezing at valves and other restricted passages. Feron has high dielectric strength and good arc extinguishing properties, but it is expensive, and it is disintegrated by the arc into acid-forming elements. The desirable features to be found in air blast circuit breaker are

High-Speed Operation – It is very necessary on large interconnected networks so that the system stability can be maintained. This is achieved in circuit breaker because the time interval between the discharge of triggering impulse and contacts separation are very short.

Suitability for frequent operation – Repeated switching by an air blast circuit is possible simply because of the absence of oil, which rapidly carbonizes with the frequent operation and because there is an insignificant amount of wear and tear at the current-carrying contact surfaces. But it must be remembered that if frequent switching is anticipated, then the maintenance of a sufficient air supply is essential.

Negligible Maintenance – The ability of the air blast circuit breaker to deal with repeated switching also mean that negligible maintenance is required.

Elimination of Fire Hazard – Because of the absence of oil the risk of fire is eliminated.

Reduced Size – The growth of dielectric strength is so rapid in air blast circuit breakers that final gap required for arc extinction is very small. This reduces the sizes of the devices.

Principle of Arc Extinction in Circuit Breaker

The air blast needs an additional compressed air system which supplies air to the air receiver. When opening air is required, compressed air is admitted to the arc extinction chamber. It pushes away the moving contacts. In doing so, the contacts are pulled apart, and the air blast moves away the ionized gas along with it and assists arc extinction.

Air blast extinguishes the arc within one or more cycles, and the arc chamber is filled with high-pressure air, which prevents restrikes. The air blast circuit breakers fall under the category of external extinguishing energy type. The energy supplied for arc quenching is achieved from the high-pressure air, and it is free from the current to be interrupted.

4.13 Types of Air Blast Circuit Breaker

All air blast circuit breakers follow the principle of separating their contacts in a flow of arc established by the opening of a blast valve. The arc which is drawn is usually rapidly positioned centrally through a nozzle where it is kept to a fixed length and is subjected to the maximum range by the air flow. The air blast circuit breakers according to the type of flow of blast of compressed around the contacts are of three types namely axial, radial and cross blast.

Axial blast Air Circuit Breaker – In the air blast circuit breaker, the flow of air is longitudinal along the arc. Air blast circuit breaker may be a single blast or double blast. Breaking employing double blast arrangement are sometimes called radial blast circuit breakers as the air blast flows radially into the nozzle or space between the contacts.

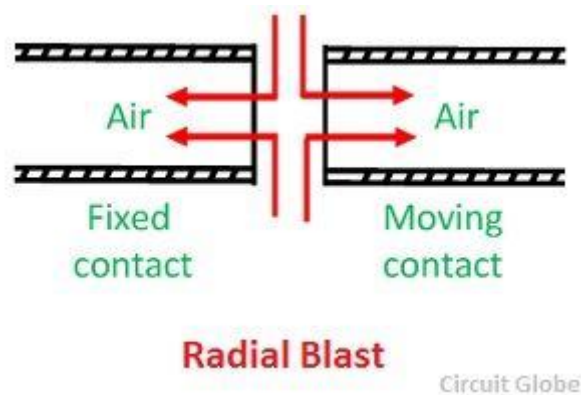

Fig 4.12

The essential feature of air blast circuit breaker is shown above. The fixed and moving contacts are kept in a closed position by spring pressure under normal operating conditions. The air reservoir tank is connected to the arc chamber through an air valve, which is opened by a triple impulse.

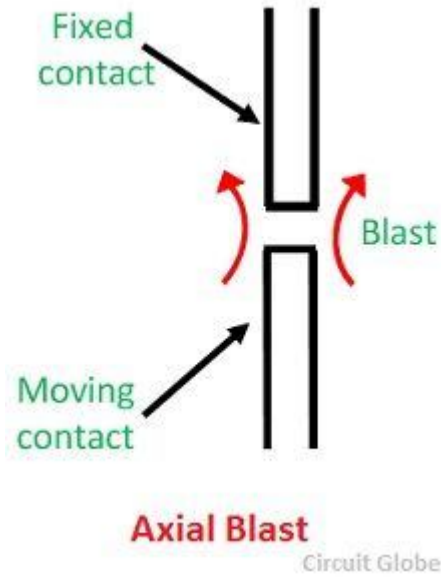

Fig 4.13

When the fault occurs, the tripping impulse causes opening of the air valve connecting the reservoir to the arcing chamber. The air entering the arc chamber exerts pressure on the moving contacts which moves when the air pressure exceeds the spring force.

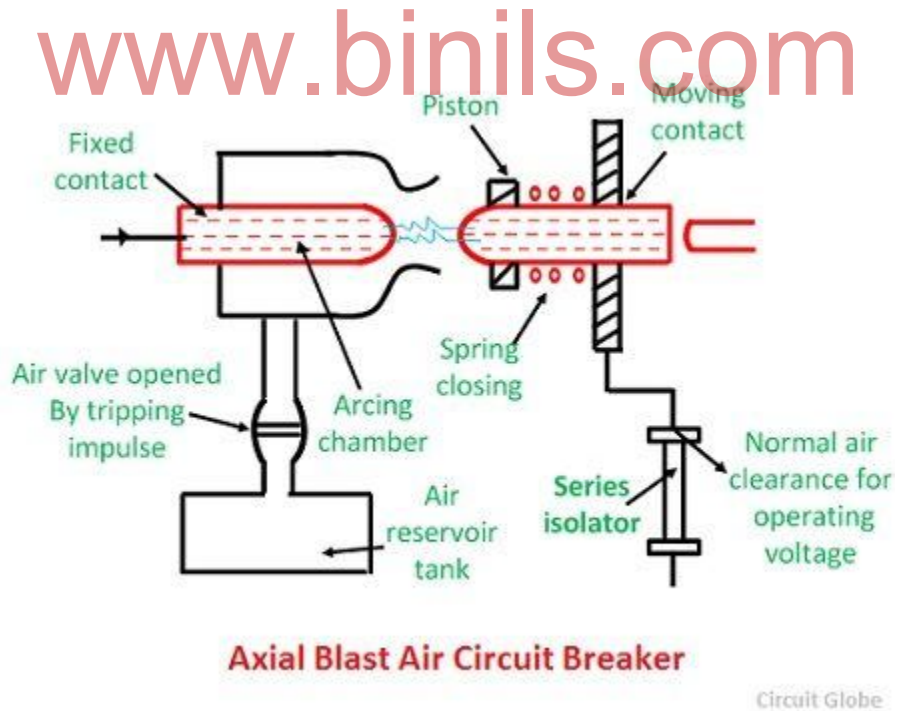

Fig 4.14

The contacts are separated, and an arc is developed between them. The air flowing at a great speed axially along the arc cause removal of heat from the edge of the arc and the diameter of the arc reduced to a very small value at current zero.

Thus, the arc is interrupted, and the space between the contact is flushed with fresh air flowing through the nozzle. The flow of fresh air removes the hot gasses between the contact space and rapidly build up the dielectric strength between them.

Cross Blast Air Circuit Breaker – In such breaker, an arc blast is directed at right angles to the arc. The schematic representation of the cross principle of cross blast air circuit breaker is given in the figure below. A moving contact arm is operated in close spaces to draw an arc which is forced by a transverse blast of air into the splitter plates, thereby lightening it to the point when it cannot restrike after zero current.

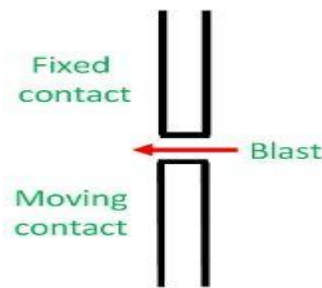

Fig 4.15

Resistance switching is not normally required as the lightening of arc automatically introduces some resistance to control the restriking voltage transient but if extra resistance is thought desirable. It is possible to introduce it by connecting it in the section across the arc splitter.

Drawback of Air Blast Circuit Breaker

In the air blast circuit breaker, it is necessary that the compressed air at the correct pressure must be available all the times, involving in the largest installation of a plant with two or more compressors. The maintenance of this plant and the problem of air leakages at the pipe fittings are some factors which operate against air blast circuit breaker and it costly for low voltage as compared to oil or air break circuit breaker.

4.14 Earth Leakage Circuit Breaker (ELCB)



Fig 4.16

An **Earth Leakage** Circuit Breaker (ELCB) is a device used to directly detect currents leaking to earth from an installation and cut the power and mainly used in TT earthing systems.

There are two types of ELCBs:

1. Voltage Earth Leakage **Circuit Breaker** (voltage-ELCB)
2. Current Earth Leakage Circuit Breaker (Current-ELCB).

Voltage-ELCBs were first introduced about sixty years ago and Current-ELCB was first introduced about forty years ago. For many years, the voltage operated ELCB and the differential current operated ELCB were both referred to as ELCBs because it was a simpler name to remember. But the use of a common name for two different devices gave rise to considerable confusion in the electrical industry.

If the wrong type was used on an installation, the level of protection given could be substantially less than that intended.

To ignore this confusion, IEC decided to apply the term Residual Current Device (RCD) to differential current operated ELCBs. Residual current refers to any current over and above the load current.

Voltage Based ELCB

- Voltage-ELCB is a voltage operated circuit breaker. The device will function when the Current passes through the ELCB. Voltage-ELCB contains relay Coil which it being connected to the metallic load body at one end and it is connected to ground wire at the other end.
- If the voltage of the Equipment body is rise (by touching phase to metal part or failure of **insulation of equipment**) which could cause the difference between earth and load body voltage, the danger of electric shock will occur. This voltage difference will produce an electric current from the load metallic body passes the relay loop and to earth. When voltage on the equipment metallic body rose to the danger level which exceed to 50Volt, the flowing current

through relay loop could move the relay contact by disconnecting the supply current to avoid from any danger electric shock.

- The ELCB detects fault currents from live to the earth (ground) wire within the installation it protects. If sufficient voltage appears across the ELCB's sense coil, it will switch off the power, and remain off until manually reset. A voltage-sensing ELCB does not sense fault currents from live to any other earthed body.

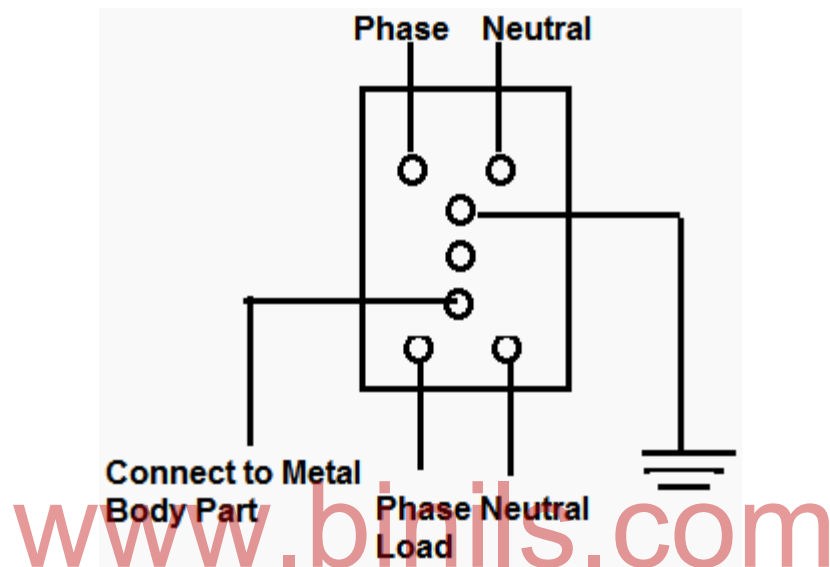

Fig 4.17

- These ELCBs monitored the voltage on the earth wire, and disconnected the supply if the earth wire voltage was over 50 volts.
- These devices are no longer used due to its drawbacks like if the fault is between live and a circuit earth, they will disconnect the supply. However, if the fault is between live and some other earth (such as a person or a metal water pipe), they will NOT disconnect, as the voltage on the circuit earth will not change. Even if the fault is between live and a circuit earth, parallel earth paths created via gas or water pipes can result in the ELCB being bypassed. Most of the fault current will flow via the gas or water pipes, since a single earth stake will inevitably have a much higher impedance than hundreds of meters of metal service pipes buried in the ground.
- **The way to identify an ELCB is by looking for green or green and yellow earth wires entering the device.** They rely on voltage returning to the trip via the earth wire during a fault and afford only limited protection to the installation and no personal protection at all. You should use plug in 30mA RCD's for any appliances and extension leads that may be used outside as a minimum.

Advantages

- ELCBs have one advantage over RCDs: they are less sensitive to fault conditions, and therefore have fewer nuisance trips.
- While voltage and current on the earth line is usually fault current from a live wire, this is not always the case, thus there are situations in which an ELCB can nuisance trip.
- When an installation has two connections to earth, a nearby high current lightning strike will cause a voltage gradient in the soil, presenting the ELCB sense coil with enough voltage to cause it to trip.
- If the installation's earth rod is placed close to the earth rod of a neighboring building, a high earth leakage current in the other building can raise the local ground potential and cause a voltage difference across the two earths, again tripping the ELCB.
- If there is an accumulated or burden of currents caused by items with lowered insulation resistance due to older equipment, or with heating elements, or rain conditions can cause the insulation resistance to lower due to moisture tracking. If there is a some mA which is equal to ELCB rating than ELCB may give nuisance Tripping.
- If either of the earth wires become disconnected from the ELCB, it will no longer trip or the installation will often no longer be properly earthed.
- Some ELCBs do not respond to rectified fault current. This issue is common for ELCBs and RCDs, but ELCBs are on average much older than RCB so an old ELCB is more likely to have some uncommon fault current waveform that it will not respond to.
- Voltage-operated ELCB are the requirement for a second connection, and the possibility that any additional connection to earth on the protected system can disable the detector.
- Nuisance tripping especially during thunderstorms.

Disadvantages

- They do not detect faults that don't pass current through the CPC to the earth rod.
- They do not allow a single building system to be easily split into multiple sections with independent fault protection, because earthing systems are usually use common earth Rod.
- They may be tripped by external voltages from something connected to the earthing system such as metal pipes, a TN-S earth or a TN-C-S combined neutral and earth.
- As electrically leaky appliances such as some water heaters, washing machines and cookers may cause the ELCB to trip.
- ELCBs introduce additional resistance and an additional point of failure into the earthing system.

4.15 Current-operated ELCB (RCB)

- Current-operated ELCBs are generally known as Residual-current devices (RCD). These also protect against earth leakage. Both circuit conductors (supply and return) are run through a sensing coil; any imbalance of the currents means the magnetic field does not perfectly cancel. The device detects the imbalance and trips the contact.
- .When the term ELCB is used it usually means a voltage-operated device. Similar devices that are current operated are called residual-current devices. However, some companies use the term

ELCB to distinguish high sensitivity current operated 3 phase devices that trip in the milliamp range from traditional 3 phase ground fault devices that operate at much higher currents.



Fig 4.18

- **Typical RCB circuit:**

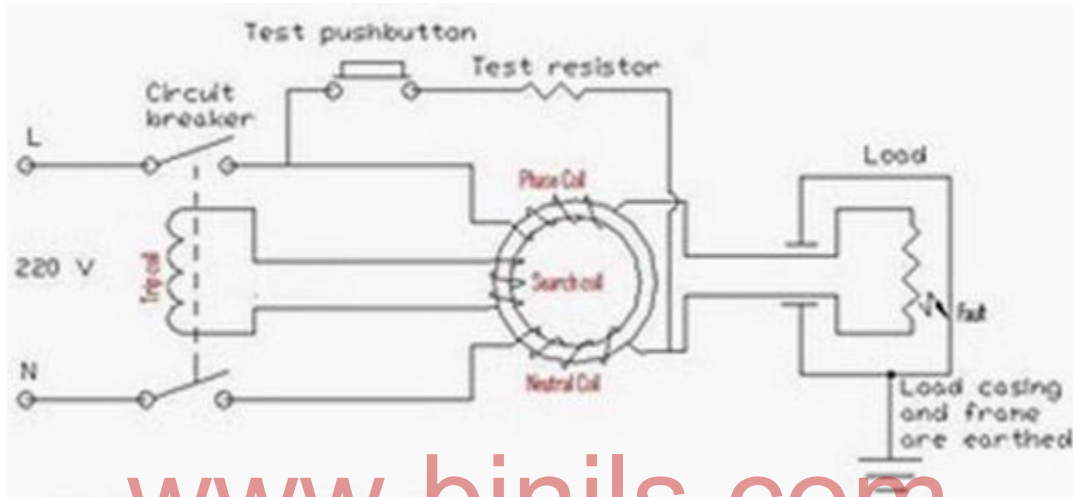

www.binils.com

Fig 4.19

- The supply coil, the neutral coil and the search coil all wound on a common transformer core.
- On a healthy circuit the same current passes through the phase coil, the load and return back through the neutral coil. Both the phase and the neutral coils are wound in such a way that they will produce an opposing magnetic flux. With the same current passing through both coils, their magnetic effect will cancel out under a healthy circuit condition.
- In a situation when there is fault or a leakage to earth in the load circuit, or anywhere between the load circuit and the output connection of the RCB circuit, the current returning through the neutral coil has been reduced. Then the magnetic flux inside the transformer core is not balanced anymore. The total sum of the opposing magnetic flux is no longer zero. This net remaining flux is what we call a residual flux.
- The periodically changing residual flux inside the transformer core crosses path with the winding of the search coil. This action produces an electromotive force (e.m.f.) across the search coil. An electromotive force is actually an alternating voltage. The induced voltage across the search coil produces a current inside the wiring of the trip circuit. It is this current that operates the trip coil of the circuit breaker. Since the trip current is driven by the residual magnetic flux (the resulting

flux, the net effect between both fluxes) between the phase and the neutral coils, *it is called the residual current device*.

- With a circuit breaker incorporated as part of the circuit, the assembled system is called residual current circuit breaker (RCCB) or residual current device (RCD). The incoming current has to pass through the circuit breaker first before going to the phase coil. The return neutral path passes through the second circuit breaker pole. During tripping when a fault is detected, both the phase and neutral connection is isolated.
- RCD sensitivity is expressed as the rated residual operating current, noted $I_{\Delta n}$. Preferred values have been defined by the IEC, thus making it possible to divide RCDs into three groups according to their $I_{\Delta n}$ value.
- High sensitivity (HS): 6- 10- 30 mA (for direct-contact / life injury protection)
- Standard IEC 60755 (General requirements for residual current operated protective devices) defines three types of RCD depending on the characteristics of the fault current.
- Type AC: RCD for which tripping is ensured for residual sinusoidal alternating currents

4.16 Miniature circuit breaker (M.C.B)

MCBs or Miniature Circuit Breakers are electromechanical devices which protect an electrical circuit from an overcurrent. The overcurrent, in an electrical circuit, may result from short circuit, overload or faulty design. An MCB is a better alternative to a Fuse since it does not require replacement once an overload is detected. Unlike fuse, an MCB can be easily reset and thus offers improved operational safety and greater convenience without incurring large operating cost.

The principal of operation is simple. An MCB functions by interrupting the continuity of electrical flow through the circuit once a fault is detected. In simple terms MCB is a switch which automatically turns off when the current flowing through it passes the maximum allowable limit. Generally MCB are designed to protect against over current and over temperature faults (over heating).

There are two contacts one is fixed and the other moveable. When the current exceeds the predefined limit a solenoid forces the moveable contact to open (i.e., disconnect from the fixed contact) and the MCB turns off thereby stopping the current to flow in the circuit. In order to restart the flow of current the MCB is manually turned on. This mechanism is used to protect from the faults arising due to over current or over load.

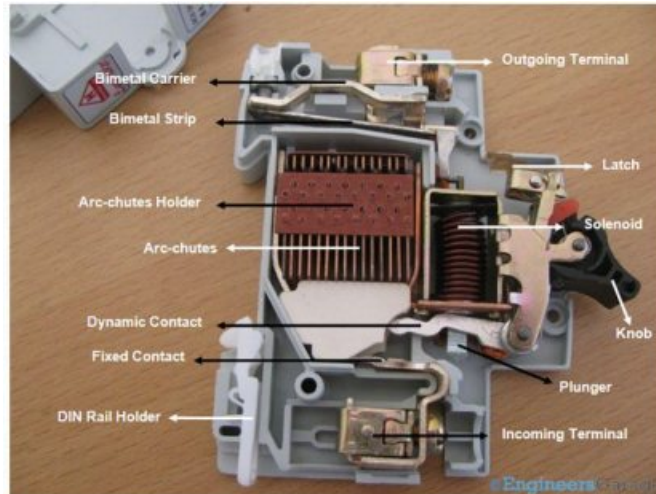

Fig 4.20

To protect against fault arising due to over heating or increase in temperature a bi-metallic strip is used. MCBs are generally designed to trip within 2.5 millisecond when an over current fault arises. In case of temperature rise or over heating it may take 2 seconds to 2 minutes for the MCB to trip.

This article covers the insight of a single pole MCB commonly used in the house hold. The following image shows the different internal parts of an MCB with top casing removed. The subsequent sections will examine each part and its function.

4.16 Residual Current Circuit Breaker (RCCB)

RCCB (Residual Current Circuit Breaker) falls under the category of wide range of circuit breakers. As we know there are several types of miniature circuit breakers like MCCB which works on different operational principle and has different safety purposes. Function: Residual Current Circuit Breaker is essentially a device which senses current and disconnects any low voltage (unbalanced current) circuit whenever there is any fault occurs. Purpose: Residual Current Circuit Breaker basically is installed to prevent human from shocks or death caused by shocks. It prevents accidents by disconnecting the main circuit within fraction of seconds.

How it Works:

It has very simple working based on Kirchhoff's Current Law ie the incoming current in a circuit must be equal to the outgoing current from that circuit. This circuit breaker is made such that whenever a fault occurs the current balance of line and neutral did not matches (imbalance occurs, as the fault current finds another earthing path of current). The circuit is made such that an every instance it compares the value of incoming and outgoing circuit current. Whenever it is not equal, the residual current which is basically the difference between the two currents actuates the circuit to trip/switch off.

Working Principle of Residual Current Circuit Breaker

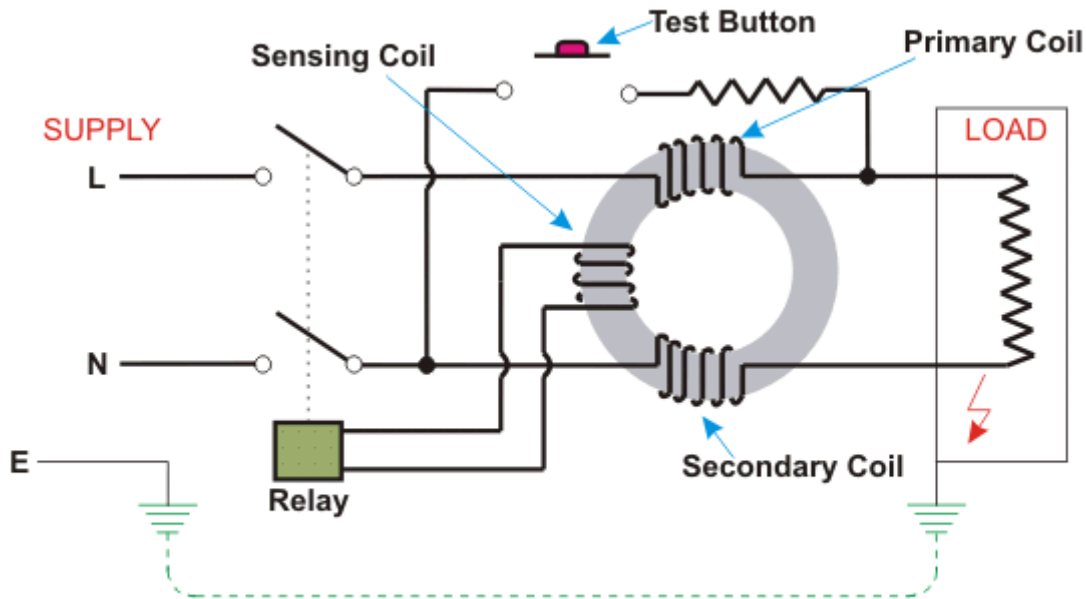

Working Principle of Residual Current Circuit Breaker

Fig 4.21
www.binils.com

The basic operating principle lies in the Toroidal Transformer shown in the fig 4.21 containing three coils. There are two coils such as Primary (containing line current) and Secondary (containing neutral current) which produces equal and opposite fluxes if both currents are equal.

Whenever there is a fault both the currents changes, it creates out of balance flux, which in-turn produces the differential current which flows through the third coil (sensing coil shown in the figure) which is connected to relay.

The Toroidal transformer, sensing coil and relay together is known as RCD - Residual Current Device.

Test Circuit:

The test circuit is always included with the RCD which basically connects between the line conductor on the load side and the supply neutral. It helps to test the circuit when it is on or off the live supply. Whenever the test button is pushed current starts flowing through the test circuit depending upon the resistance provided in this circuit. This current passes through the RCD line side coil along with load current. But as this circuit bypasses neutral side coil of RCD, there will be an unbalance between the line side and neutral side coil of the device and consequently, the RCCB trips to disconnect the supply even in normal condition. This is how the test circuit tests the reliability of **RCCB**.

4.16.1 Types of Residual Current Circuit Breaker

2 Pole: It is for single phase line consisting of one live and one neutral wire slot in it.

4 Pole: It is designed for three phase line consisting of 4 slots where three phase wires and a neutral wire can be connected.

4.17 SF₆ Circuit Breaker

In the SF₆ circuit breaker, the current carrying contacts operate in the medium sulphur hexafluoride gas which is known as an SF₆ circuit breaker. It is an excellent insulating property and high electro-negativity. It can be understood that, high affinity of absorbing free electron. The negative ion is formed when a free electron collides with the SF₆ gas molecule; it is absorbed by that gas molecule. The two different ways of attachment of electron with SF₆ gas molecules are

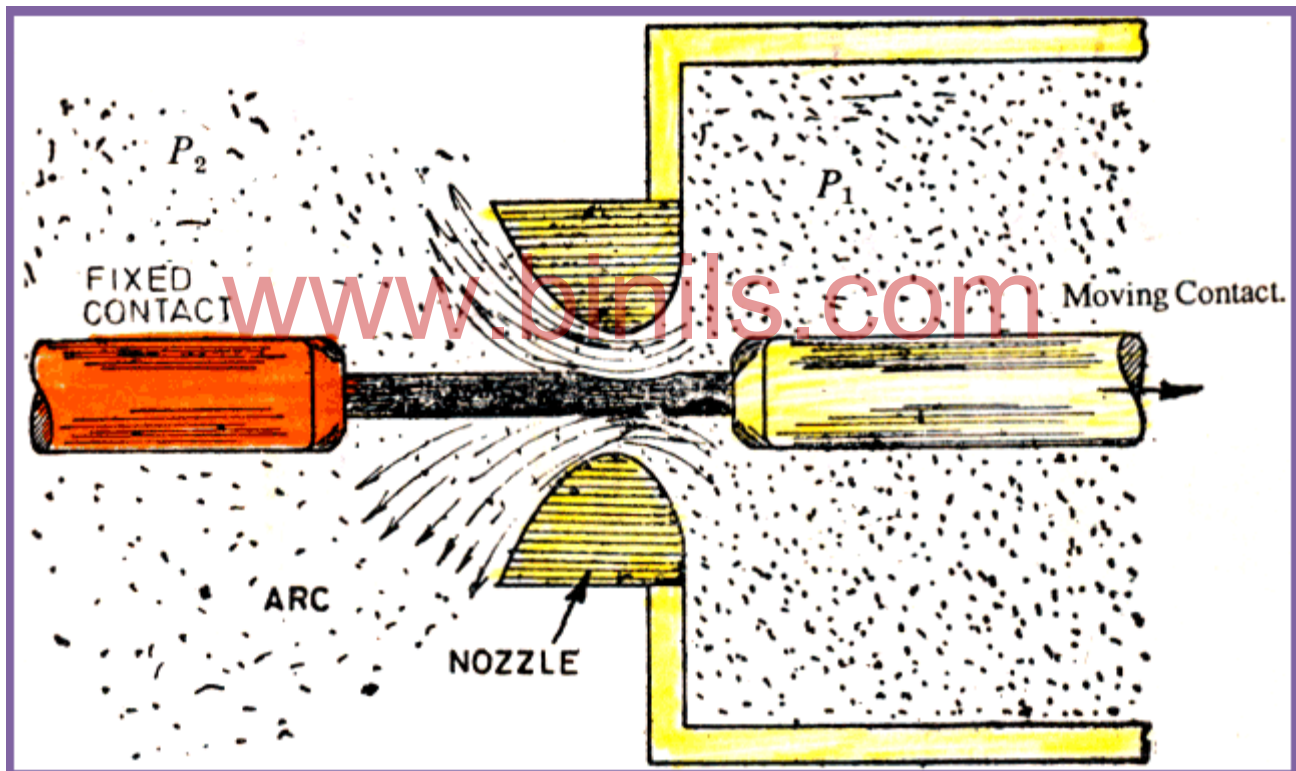
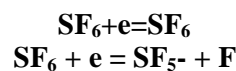

Fig 4.22 SF₆ Circuit Breaker

The negative ions which are formed will be much heavier than a free electron. Therefore, when compared with other common gases overall mobility of the charged particle in the SF₆ gas is much less. The mobility of charged particles is majorly responsible for conducting current through a gas. Hence, for heavier and less mobile charged particles in SF₆ gas, it acquires very high dielectric strength. This is a good heat transfer property because of low gaseous viscosity. SF₆ is 100 times more effective in arc quenching media than air circuit breaker. It is used for both medium and high voltage electrical power systems from 33KV to 800KV.

Types of SF₆ Circuit Breaker

- Single interrupter SF₆ circuit breaker applied up to 220
- Two interrupter SF₆ circuit breaker applied up to 400
- Four interrupter SF₆ circuit breaker applied up to 715V

4.18 Vacuum Circuit Breaker

A Vacuum circuit breaker is a circuit where vacuum is used to extinct the arc. It has dielectric recovery character, excellent interruption and can interrupt the high frequency current which results from arc instability, superimposed on the line frequency current.

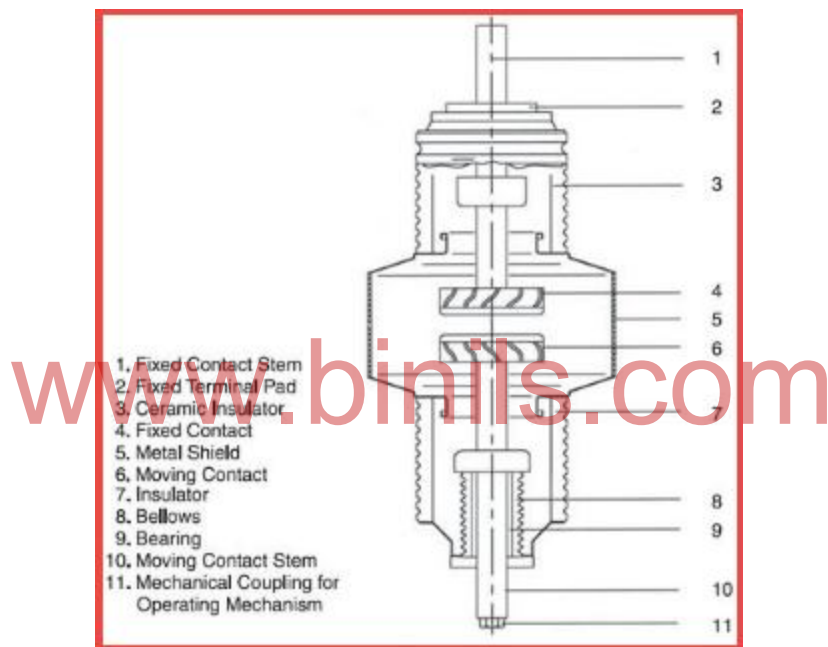

Fig 4.23 Vacuum Circuit Breaker

The VCB will have two contacts called electrodes. They will remain closed under normal operating conditions. Suppose when a fault occurs in any part of the system, then the trip coil of the circuit breaker gets energized and finally contact gets separated.

The moment contacts of the breaker are opened in vacuum, i.e. 10⁻⁷ to 10⁻⁵ Torr an arc is produced between the contacts by the ionization of metal vapors of contacts. Here the arc quickly gets extinguished, this happens because the electrons, metallic vapors and ions produced during arc, condense quickly on the surface of the CB contacts, resulting in quick recovery of dielectric strength.

Advantages

- VCBs are reliable, compact and long life
- They can interrupt any fault current.
- There will be no fire hazards.

- No noise is produced
- It has higher dielectric strength.
- It requires less power for control operation.

4.19 Fuses

An electrical fuse is a simple device used to interrupt an electrical circuit during over current condition due to short circuit and/or overload. An electrical fuse operates on the principle of heating effect of electric current. During normal operating condition, the current flowing through the fusing element is such that the rate of heat production in the fuse element is nearly equal to the rate of heat dissipation from the fuse element and thereby they will be no considerable increase of temperature of that fuse element.

Materials Used For Fuse Element

The main properties of a fuse element are

1. They must have low melting point.
2. They must have low ohmic loss.
3. They must have low resistivity.
4. They must be free from deterioration.
5. They must be of moderate cost.

The metals like tin, lead and zinc are having all the above mentioned properties hence used widely as fuse element. Although silver has very high cost but still it is used as fuse element where cost is not the main criteria of application.

Current rating of fuse element

It is the current which the fuse element can carry without overheating or melting. It depends on the temperature rise in the contacts of the fuse holder, fuse material and the surrounding of the fuse.

Fuse Current

It is the minimum current at which the fuse element melts. Its value will be higher than the current rating of the fuse element.

For a round wire the approximate relationship between the fuse current I and the diameter d of the wire is given by

$$I = kd^{3/2}$$

k is a constant called the fuse constant. The value of k depends on the material used for making fuse element.

The value of k for various elements as found by Sir William Henry Preece is given below

Table1: Value of k for different elements

Sl. No.	Material	Value of k	
		d in cm	d in mm
1	Copper	2530	80
2	Aluminium	1873	59
3	Tin	405.5	12.8
4	Lead	340.6	10.8

The fusing current depends on various factors such as:

- Material of the fuse element
- Length: smaller the length greater the current because a short fuse can conduct away all the heat
- Diameter
- Size and location of the terminals
- Previous history
- Type of enclosure used

Fusing factor

It is the ration of fusing current to the current rating of the fuse element.

Fusing Factor = Fuse current/Current rating of fuse

The value of fusing factor is always greater than 1. The small the value of fusing factor, greater is the chance of deterioration of fusing element due to overheating and oxidation. For a semi enclosed or rewirable fuse which employ copper as the fuse element, the value of fuse factor is usually 2. Lower values of fusing factor can be employed for enclosed type cartridge fuse which uses silver or bimetallic elements.

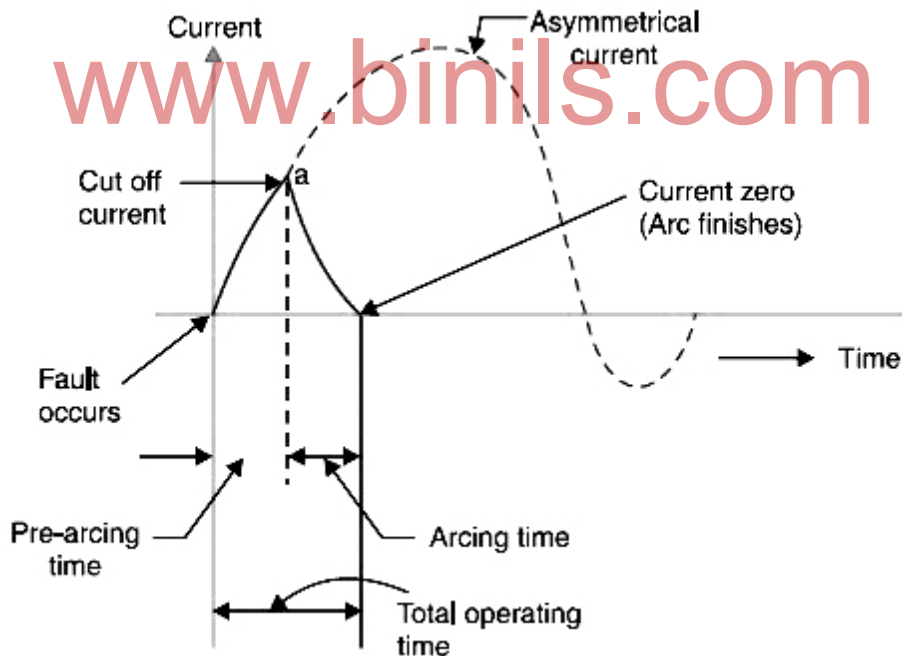

Figure 4.24. AC Current Cut-off by Fuse

Prospective Current

From Figure 2 the fault current would normally have a large first loop but it generate sufficient energy to melt the fuse element before the peak value of the first loop is reached. The rms value of the first loop of fault current is known as prospective current. Prospective current is defined as the rms value of first loop of fault current is the fuse is replaced by an ordinary conductor of negligible resistance.

Cut-Off Current

It is the maximum value of fault current reached when the fuse melts. The current corresponding to the point 'a' is called cut-off current. The cut-off value depends on

- Current rating of the fuse
- Value of prospective current
- Asymmetry of the fault current

Pre-arcing Time

It is the time between commencement of the fault current and the instant when cut-off occurs. When a fault occurs, the fault current rises rapidly and as the fault current reaches a cut-off value the fuse melts and an arc is initiated. The time between the occurrence of the fault and the instant the arc is initiated is called the pre-arcing time. The value of pre-arcing time is generally small and a typical value is 0.001 second.

Arcing Time

The time between the pre-arcing time and the instant at which the arc is extinguished.

Total Operating Time

The sum of pre-arcing and arcing times is called total operating time. It may be noted that the operating time of a fuse (0.002seconds) is much lower than that of a circuit breaker (0.2 seconds). A fuse in series with a circuit breaker of low breaking capacity is useful and economical way of providing adequate short circuit protection. In that case the fuse will blow fast even before the circuit breaker begins to operate.

Breaking Capacity

It is the rms value of the AC component of maximum prospective current that a fuse can deal with at a rated service voltage.

Types of Fuses

Since its invention, a lot of improvements have been made and now a variety of fuses are available. Some fuses even have arrangements to extinguish the arc that appears when the fuel element melts. Fuses are generally classified into two:

- Low voltage fuses
- High voltage fuses

Low Voltage Fuses

Low Voltage Fuses are of two types

- Semi Enclosed Rewirable Fuse
- High Rupturing Capacity (HRC) Cartridge Fuses

Semi Enclosed Rewirable Fuse

Rewirable fuses also known as kit-kat type fuses are used to interrupt fault currents of lower magnitude. It consists of two parts: a base and a fuse carrier. The base is made of porcelain and carrier the fixed contacts to which the incoming and outgoing phase wires are connected. The fuse carrier is also made of porcelain and fuse elements between the terminals. The fuse carrier can be inserted or removed at any time.



Figure 4.23: Semi Enclosed Rewirable Fuses

When a fault occurs the fuse element is blown out and the circuit is interrupted. The fuse carrier can be taken out and the blown out fuse element can be replaced by a new one. It is then inserted to the base to restore the supply.

Advantages:

- Detachable fuse carrier permits the replacement of fuse element without coming in contact with live parts.
- Cost of replacement is negligible.

Disadvantages:

- Possibility of renewal with fuse wire of wrong size and improper material.
- Low breaking capacity, so cannot be used in circuits with higher fault current levels.

- The fuse element is subjected to deterioration by oxidation through the continuous heating up of the element. This reduces the current rating of the fuse. Thus the fuse operates at a current lower than the rated value.
- Uncertainty in the protective capacity of the fuse since it is affected by ambient conditions.
- Accurate calibration of the fuse is not possible as the fusing current depends on the length of the fusing element.

Semi enclosed rewirable fuses have capacity up to 500A but their breaking capacity is much lower so their use is limited to domestic and lighting applications only.

High Rupturing Capacity (HRC) Cartridge Fuse

The shortcomings of uncertain and low breaking capacity of semi enclosed rewirable fuse are overcome in HRC cartridge fuse. It consists of a heat resisting ceramic body with metal end caps to which is welded silver current carrying element. The space surrounding the element is completely packed with a filling powder. The filling powder can be of chalk, plaster of paris, quartz or marble dust and act as an arc quenching and cooling medium.

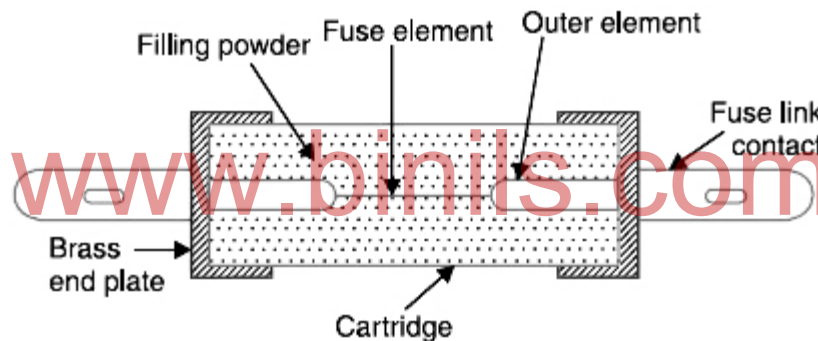

Figure 4.24: Parts of a typical HRC Fuse



Figure 4.25: HRC Fuses

The HRC cartridge fuse carries the normal current without overheating. During the occurrence of a fault, the current increases and the fuse element melts before the fault current reaches its first peak. The heat produced in the process vaporises the melted silver element. The chemical reaction between the silver vapours and the filling powder results in a high resistance substance that helps in quenching the arc.

Advantages

- Capable of clearing high as well as low fault currents
- Does not deteriorate with age
- High speed of operation
- Provide reliable discrimination
- Require no maintenance
- Cheaper than other circuit interrupting devices of equal breaking capacity

Disadvantages

- Must be replaced after operation
- Heat produced by the arc may affect the associated switches

High Rupturing Capacity Fuse with Tripping device

In some cases, the HRC fuse is provided with a tripping device. During the occurrence of a fault the fuse is blown out and the tripping device causes the circuit breaker to operate. The body of the fuse is made of a ceramic material with a metal cap attached rigidly to both ends. The caps are connected by a number of silver fuse elements. At one end of the fuse there is a plunger. Under fault condition it hits the tripping mechanism of the circuit breaker and causes it to operate. The plunger is electrically connected by means of a fusible link, chemical charge and a tungsten shunt to the other end of the cap.

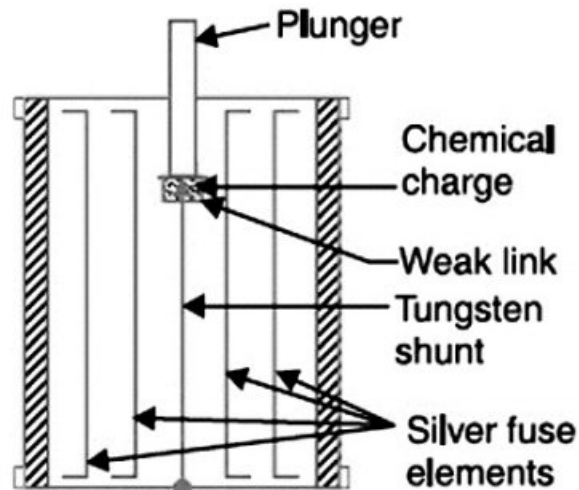

Figure 4.26 HRC Fuse with Trigger Mechanism

When fault occurs, the silver fuse elements are the first to be blown out and the current is then transferred to the tungsten wire. The weak link in series with the tungsten wire gets fused and causes the chemical charge to be detonated. This forces the plunger to move outward to operate the circuit breaker. The travel of the plunger is so set that it is not ejected from the fuse body under the fault conditions.

Advantages over the fuse without triggering device

- In case of a single phase fault on a three phase system, the plunger operates the tripping mechanism of circuit breaker to open all the three phase and thus prevents 'single phasing'
- The effect of full short circuiting need not be considered in the choice of circuit breaker. This prevents from the use of expensive circuit breakers
- The fuse tripped circuit breaker is generally capable of dealing with fairly small fault current itself. This avoids the necessity for replacing the fuse except after highest currents for which it is intended

High Voltage fuses

Due to the fact that the low voltage fuses has low current rating and breaking capacity they cannot be used for modern high voltage systems. With the advancement in technology researches found a way to protect the high voltage circuits; the high voltage fuses.



Figure 4.27: High Voltage Fuses

Some of the high voltage fuses are:

Cartridge type fuses

The construction of high voltage cartridge fuse is similar to that of a low voltage cartridge fuse except that special features are incorporated in the former. On some design the fuse element is wound in the form of a helix so as to avoid the effects due to corona at high voltages. In another design, there are two fuse elements in parallel, one low resistance (silver wire) and one high resistance (tungsten wire). Under normal operating conditions the low resistance element carries the normal current. During the occurrence of a fault the low resistance element is blown out and the high resistance element reduces the short circuit current and finally breaks the circuit. High voltage cartridge fuses are used up to 33kV with breaking capacity of about 8700A. Ratings in the order of 200A at 6.6kV and 11kV and 50A at 33kV are also available.

Liquid type fuses

These fuses are filled with carbon tetrachloride and they have wide range of application in high voltage systems. They may be used in circuits with 100A rated current in 132kV system. The breaking capacity is of the order of 6100A. It consists of a glass tube filled with carbon tetrachloride solution with both ends sealed with brass caps. The fuse wire is sealed at one end of the tube and the other end is held strongly by a phosphor bronze spiral spring fixed at one end of the glass tube.

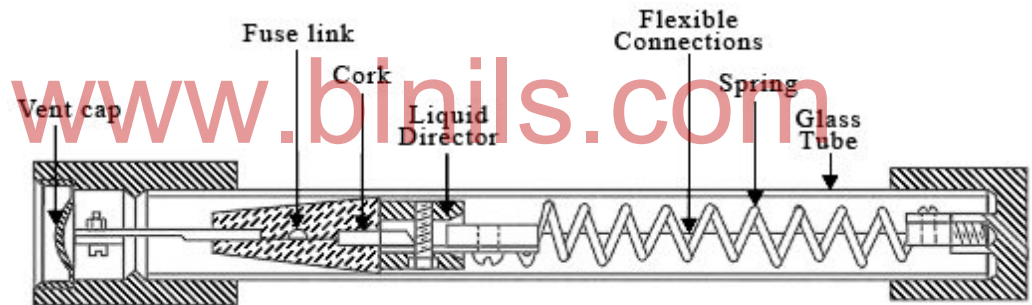

Figure 4.28: Parts of High Voltage Liquid fuse Fuse



Figure 4.29 : High Voltage Liquid Fuse

Fig 4.29 shows the essential parts of a liquid fuse. When the current exceeds the predetermined limit the fuse wire is blown out. As the fuse wire melts the spring retracts the part of the wire through liquid director and draws it completely into the liquid. The small quantity of gas generated at the point of fusion forces part of the liquid into the passage through liquid director and it effectively extinguish the arc.

Metal clad fuses

Metal clad oil immersed fuses were developed as a substitute for oil circuit breakers. They operate satisfactorily under fault conditions in high voltage circuits.

4.21 Comparison of fuse and circuit breaker

BASIS	FUSE	CIRCUIT BREAKER
Working Principle	Fuse works on the electrical and thermal properties of the conducting materials.	Circuit breaker works on the Electromagnetism and switching principle.
Reusability	Fuses can be used only once.	Circuit breakers can be used a number of times.
Status indication	It does not give any indication.	It gives an indication of the status
Auxiliary contact	No auxiliary contact is required.	They are available with auxiliary contact.
Switching Action	Fuse cannot be used as an ON/OFF switch.	The Circuit breaker is used as an ON/OFF switches.
Temperature	They are independent of ambient temperature	Circuit breaker Depends on ambient temperature
Characteristic Curve	The Characteristic curve shifts because of the ageing effect.	The characteristic curve does not shift.
Protection	The Fuse provides protection against only power overloads	Circuit breaker provides protection against power overloads and short circuits.
Function	It provides both detection and interruption process.	Circuit breaker performs only interruption. Faults are detected by relay system.
Breaking capacity	Breaking capacity of the fuse is low as compared to the circuit breaker.	Breaking capacity is high.
Operating time	Operating time of fuse is very less (0.002seconds)	Operating time is comparatively more than that of the fuse. (0.02 – 0.05 seconds)
Version	Only single pole version is available.	Single and multiple versions are available.
Mode of operation	Completely automatically.	Manually as well as automatically operated.
Cost	Cost of fuse is low.	Cost of circuit breaker is high.

4.22 Over voltage protection:

Voltage Surge

Definition:

Voltage surge is defined as the sudden rise in excessive voltage which damages the electrical equipment of an installation. The overvoltage in the lines occurs because of a rise in voltage between both phases and between phase and ground. The voltage surges are mainly classified under two heading; internal and external voltages.

Types of Voltage Surge

The overvoltage in the power station can be caused either by the internal disturbance or by the atmospheric eruption. On the basis of the generation of overvoltage's the voltage surge are classified into two categories. These are

1. Internal Overvoltage
2. External Overvoltage

Causes of over voltage

These abnormal over voltages may be caused due to various reason such as, sudden interruption of heavy load, lightening impulses, switching impulses etc.

The overvoltage of a power system may be broadly divided into two main categories viz.

A) Internal Causes

1. **Switching Surges:** The overvoltages produced on the powersystem due to switching operations are known as switching surges.
2. **Insulation Failure:** The most common case of insulation failure in a power system is the grounding of conductor (i.e. insulation failure between line and earth) which may cause overvoltages in the system.
3. **Arcing Ground:** The phenomenon of intermittent arc taking place in line-to-ground fault of a 3-phase system with consequent production of transients is known as arc ground. This happens when there is the presence of a sporadic arc in line-to-ground fault belonging to three-phase system. Here, short-live oscillations are produced in the system due to some changes in the voltage and the current load. This phenomenon may lead to serious problems like breakdown of the insulation and may harm equipment connected to the power system.
4. **Resonance:** This one occurs when the value of the inductive resistance in the power system becomes equal with the value of capacitive resistance.

B) External Causes

This type of overvoltages originates from atmospheric disturbances, mainly due to lightning. This takes the form of a surge and has no direct relationship with the operating voltage of the line. It may be due to any of the following causes:

1. Direct lightning stroke.
2. Electromagnetically induced over voltages due to lightning discharge taking place near the line, called 'side stroke'.
3. Voltages induced due to atmospheric changes along the length of the line.
4. Electrostatically induced voltages due to presence of charged clouds nearby.
5. Electrostatically induced over voltages due to the frictional effects of small particles like dust or dry snow in the atmosphere or due to change in the altitude of the line.

4.22.1 Lightning Stroke

Definition:

Lightning stroke is the direct discharge of an electrical charge between the atmosphere and the object of earth. It is a sudden flow of electric charge between the electrical charge area of a cloud also called intra-cloud and another cloud called (CC lightning) or between the charged cloud and the ground (CG lightning).

The charge region of the cloud is equal to the electric discharge. When the cloud charge is discharged on the ground, then it is called a strike, and if the discharge is hit on the object, then it is called flash. The lightning occurs in the form of the plasma and sound in the form of thunder.

4.22.2 Mechanism of the Lightning Discharge

In the atmosphere, the positive, as well as the negative ions in the air, attach themselves to the small dust particles. The water drops present in the air also get charged because of polarisation by induction. These charged particles and water drops charged the clouds. The positive ions are collected in the upper region, and the negative ions are collected in the lower region of the cloud because of their mass.

When the charge cloud passes over the earth, it induces an opposite charge in the earth below. The potential difference in the cloud is not much greater than that at the earth's surface, the discharge originates in the clouds. The potential gradient of the clouds is not uniform, and it is of the order of 10 – 30 KV/cm in any part of the cloud. The initial discharge which is also called pilot discharge or pilot leader moves slowly towards it from the earth.

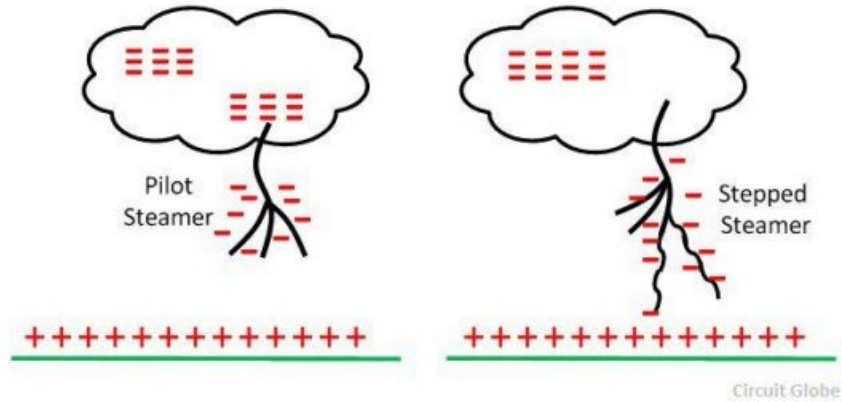

Fig 4.30

The first discharge moves to earth in steps of about 50 meters each and is, therefore, termed the stepped leader. The pilot leader carries a charge with it, and the potential gradient at its tips is very high. It ionises the air and provides a path or channel for the pilot leader. The channel also becomes charged. The pilot leader carries secondary steamer which branches out from it.

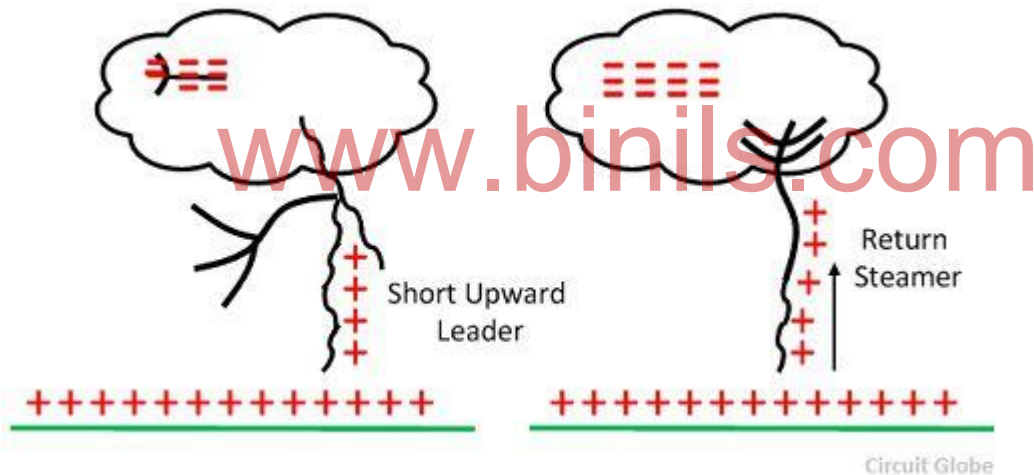

Fig 4.31

When the pilot steamer reaches near the earth, the electric field intensity increases and due to this, the charges of an opposite polarity in the form of a short steamer rises from the earth to meet the tip of downward leader. When a contact is made between the pilot leader and the short upward steamer, a return steamer travel from the earth to cloud along the ionised channel formed by the pilot leader. The return steamer moves very fast and produces the well known, intensely luminous lightning flash.

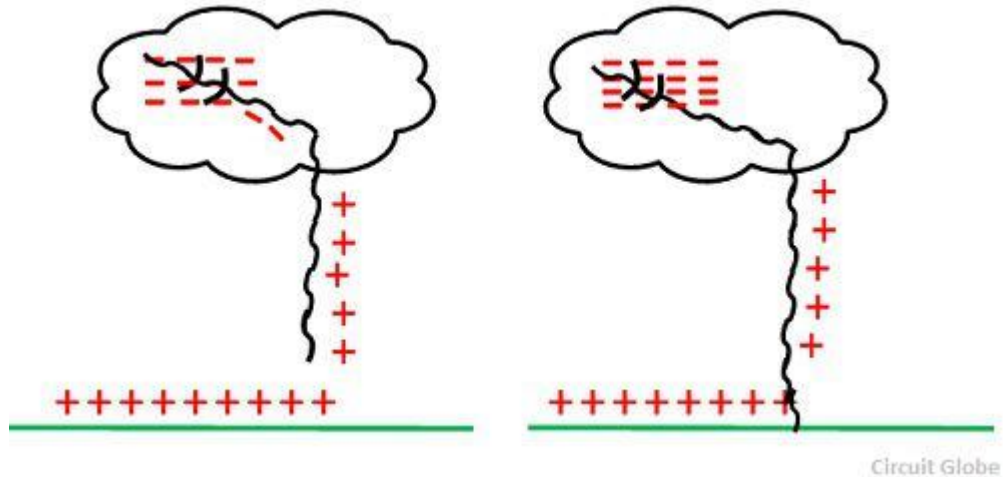

Fig 4.32

The potential of the portion of the cloud from where the discharge originated is lowered by the passage of the charge through the ionised channel to the earth. But the other portion of the clouds remains charged. Therefore, a high potential develops between the original charge centre and another charge centre in the clouds.

The charge of the other charge centre is first transferred to the first one, and then it passes to the earth through the ionised channel made by the first discharge. The second's discharge is unbranched and without steps. Its velocity is more than that of the pilot leader. This is known as the dart leader, and it is also followed by the return strokes.

Similarly, the other charges are discharged to the earth in the form of leader and return strokes along the same ionised channel. Lightning strokes with any discharge are known as multiple or repetitive strokes. The lightning is called referred to as hot or cold depending upon the magnitude and duration of the stroke.

The stroke of lightning has a low current but long duration. It causes the fire when it strokes on the object. The stroke of cold, lightning has a high current, but it is of short duration. It causes an explosion when it strikes on an object.

Waves Shapes of Stroke Currents

The wave shapes consist of a portion showing the steep rise of voltage up to a peak or crest value called the wavefront, and the other portion showing the decay of voltage called the wave tail. Such a wave shape may be represented as the difference of two exponentials, thus

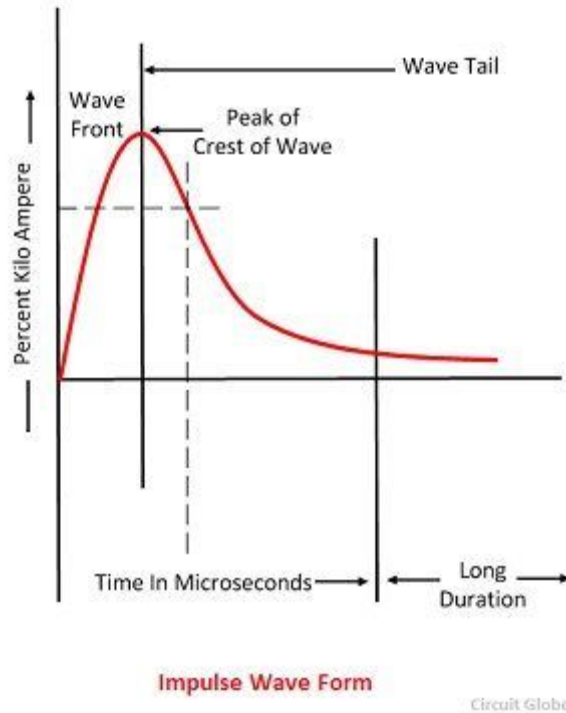

Fig 4.33

$$e = E(\epsilon^{-\alpha t} - \epsilon^{-\beta t})$$

Where the α and β show the constants which determine the shapes. The waves are defined by times t_1 and t_2 in milliseconds. The times to reach the impulse current or voltage to its maximum amplitude is denoted by t_1 , while t_2 denotes the times when the current or voltages has fallen to one-half of its peak value.

4.23 Types of Lightning Stroke

The lightning stroke affects the lines in two ways

1. Direct stroke
2. Electrostatic induction./Indirect

These types are explained below in details.

1. Direct Stroke

In the direct lightning strokes, the cloud attains a large amount of charge and induces an opposite charge on taller objects such as temple, churches or mosques. When the intensity of electrostatic field becomes sufficiently great to ionise the neighboring air, the air break down and discharge takes place between the cloud and the object. Such types of discharge take a long time to produce, and it strikes the highest and the most sharply pointed building in the neighborhood.

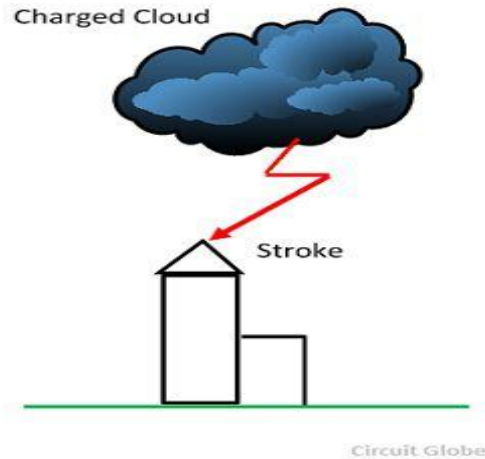

Fig 4.34

2. Electrostatic Induction Stroke

Consider the three clouds, clouds 1 and 3 are positively charged, and cloud 2 is negatively charged as shown in the figure below.

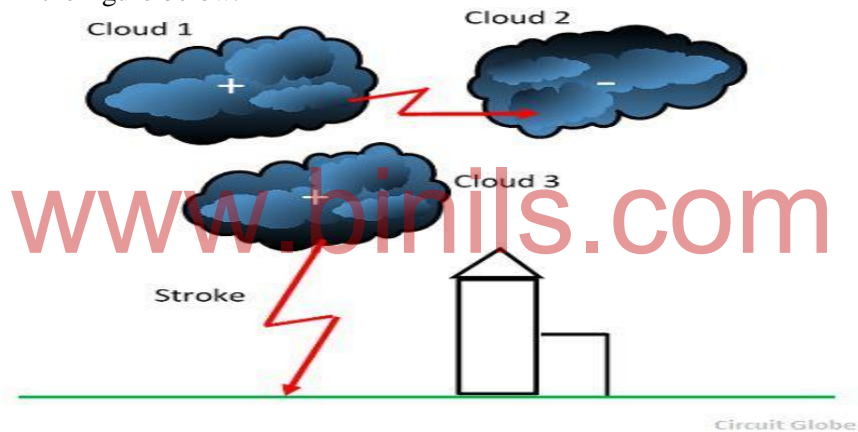

Fig 4.35

The potential of cloud 3 is reduced due to the presence of the charged cloud 2. On the flash over from Cloud 1 to Cloud 2, both these clouds are discharged rapidly, and cloud 3 assumes a much potential and flashes to earth very rapidly. It is the most dangerous strokes because it ignores taller building and reaches directly to the ground. This stroke is called the induced strokes.

4.23.1 Effect of Lightning Strike on Electrical Lines

The foregoing discussion concentrated on the principles of lightning strikes and how their effects can be mitigated. However, lightning strikes on electrical lines or substations are those that cause problems in the distribution network which come right into our residences and offices.

A direct lightning strike on a conductor of a power line causes extremely high voltage pulses at the strike point, which are propagated as traveling waves in either direction from the point of strike. The crest of the pulse can be calculated as:

$$V = I \times Z$$

Where:

V is the crest voltage

I is the peak lightning current

Z is the impedance seen by the pulse along the direction of travel.

Impedance Z is equal to half the surge impedance of the line when struck at mid-point and can be approximately as much as 150 Ω . Thus for a peak current of 40 kA, the voltage of the pulse can be as high as 6000 kV. Since the basic insulation level of most systems is much lower than this value, it is clear that such a pulse will cause failure of insulating components along the line.

It is therefore necessary that no direct strike must be permitted on the overhead power lines phase conductors.

The clearance between the phase conductors and the shield wire must be selected so that air space between them does not breakdown by the high impulse voltage generated in the shield wires. This is easily achievable in systems of 66 kV and higher.

Even when protected in the above manner, the flow of the pulse of lightning current in the shield wire causes an induced voltage pulse in the phase conductors. These being much smaller in value than the direct pulse safely pass along the line without causing any insulation failure. To protect the equipment at the termination point of the overhead lines (such as circuit breakers, transformers, measuring devices, etc.), lightning surge arrestors are provided at the point of termination. These arrestors absorb any surges in the line and prevent them from traveling into the substation equipment.

These arrestors are essentially non-linear resistors in a porcelain housing which at normal voltages present a very high resistance. They are designed to break down at voltages above the highest system operating voltage (but lower than the basic insulation level of the system) thereby becoming good conductors and pass the energy of the lightning impulse to the ground. Once the voltage comes down (after the discharge of the pulse is over) the arrestors return to their original high-impedance state.

The arrestors are placed on structures and their line terminals connected to each phase of the line. The other end of the arrestor (ground terminal) is connected to the substation grounding system through short ground conductors of adequate cross-sectional area.

Arrestors can also be optionally provided with surge counters for the purpose of monitoring their action.

Overhead Ground Wire or Earth Wire

Definition:

The overhead earth wire or ground wire is the form of lightning protection using a conductor or conductors. It is attached from support to support above the transmission line and well grounded at regular interval. The earth wire intercepts the direct lightning strikes, which would strike the phase conductors. The ground wire has no effect on switching surges.

When the lightning strikes an earth wire at mid-span, waves are produced which travel in opposite directions along the line. The waves reach the adjoining tower, which passes them to earth safely. The earth wire is effective only when the resistance between the tower foot and earth is sufficiently low.

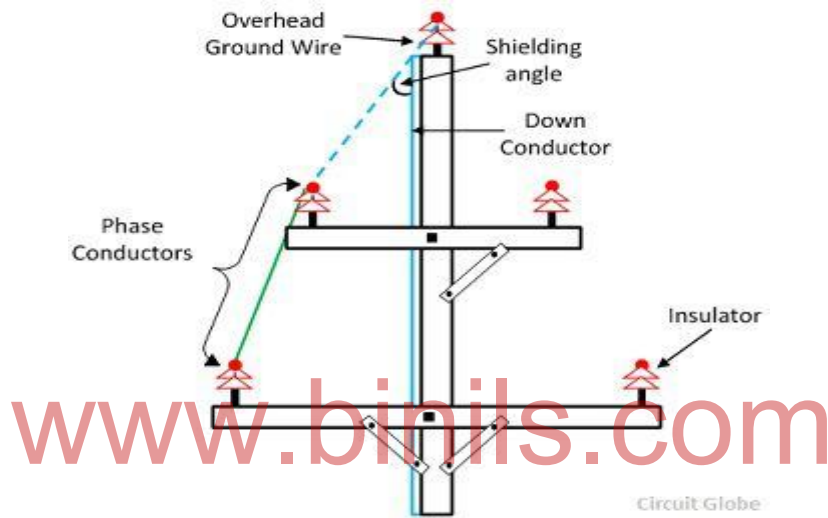

Fig 4.36

If the resistance between them is not low and the earth wire or tower will be struck by the lightning, then the lightning will be raised to the very high potential, which will cause a flash over from the tower to one or more phase conductors. Such a flashover is known as back flashover.

The back flash over only occurs when the product of the tower conductor and tower impedance exceeds the insulation levels of the line. It can be minimized by reducing tower footing resistance using driven rods and counterpoises where soil resistivity is high.

The counterpoise is the conductor buried in the ground. The wire is usually made up of galvanised steel. The counterpoise for an overhead terminal consists of a special ground terminal that reduces the surge impedance of the ground connection and increases the coupling between the ground wire and the conductor.

Two types of counterpoise are used in the transmission line, i.e., the parallel counterpoise and the radial counterpoise.

Parallel Counterpoise – The parallel counterpoise is made up of one or more counterpoise buried under the transmission line through its length. The counterpoise line connected through the over earthed wire at all the towers and poles.

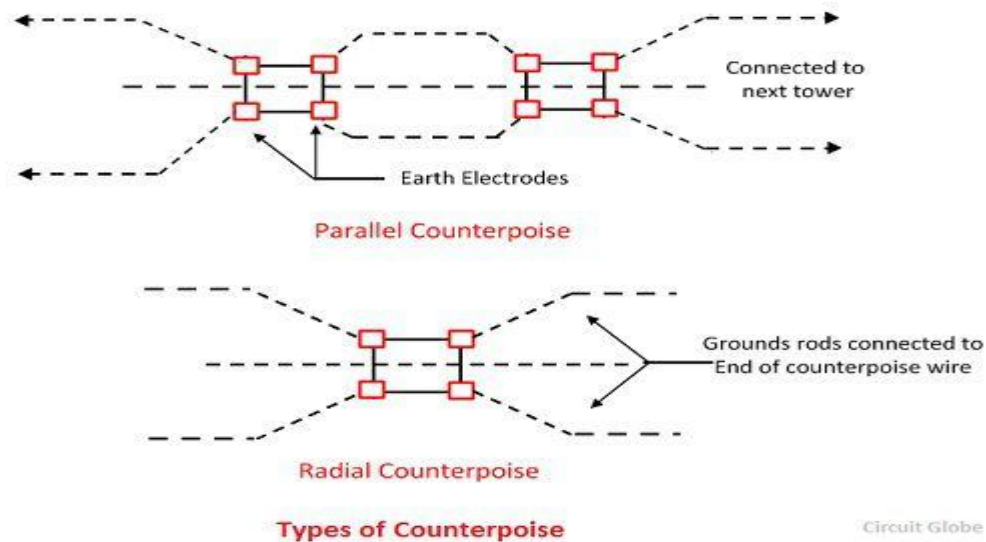

Fig 4.37

Radial Counterpoise – The radial type counterpoise is made up of many wires extending radially from the tower legs. The number and length of wires are determined by the tower location and soil conditions.

Shielding or Protective Angle

The shielding or protective angle is the angle between the vertical earth wire and the phase conductor which is to be protected. Usually, the angle between the vertical through the earth wire and the line joining the earth wire through the outermost phase conductor is taken as a shielding angle.

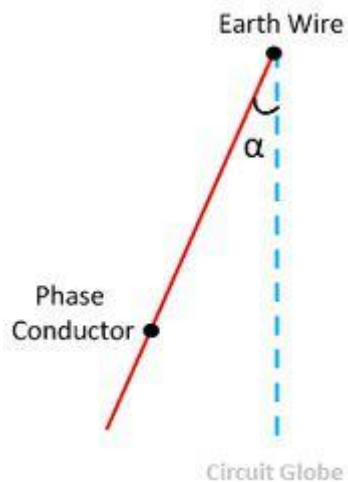

Fig 4.38

For effective shielding, the protective angle should be kept as small as possible. The angle between 20° and 30° is quite safe, and it should not be kept above 40° .

Two wires are used in modern high voltage system with wider spacing between the conductor. The protection afforded by the two wire earth wire is much better than the single wire. Also, the surge impedance for two earth wires is low and the coupling effect of the wire increases.

4.24 Types of Lightning Arresters

The lightning arrester protects the electrical equipment from lightning. It is placed very near to the equipment and when the lightning occurs the arrester diverts the high voltage wave of lightning to the ground. The selection of arrester depends on the various factors like voltage, current, reliability, etc. The lightning arrester is mainly classified into twelve types. These types are;

1. Rod Gap Arrester
2. Sphere Gap Arrester
3. Horn Gap Arrester
4. Multiple-Gap Arrester
5. Impulse Protective Gap
6. Electrolytic Arrester
7. Expulsion Type Lightning Arrester
8. Valve Type Lightning Arresters
9. Thyrite Lightning Arrester
10. Auto valve Arrester
11. Oxide Film Arrester
12. Metal Oxide Lightning Arresters

Their types are explained below in details.

1. Rod Gap Arrester

It is one of the simplest forms of the arrester. In such type of arrester, there is an air gap between the ends of two rods. The one end of the arrester is connected to the line and the second end of the rod is connected to the ground. The gap setting of the arrester should be such that it should break before the damage. When the high voltage occurs on the line, the gap sparks and the fault current passes to the earth. Hence the equipment is protected from damage.

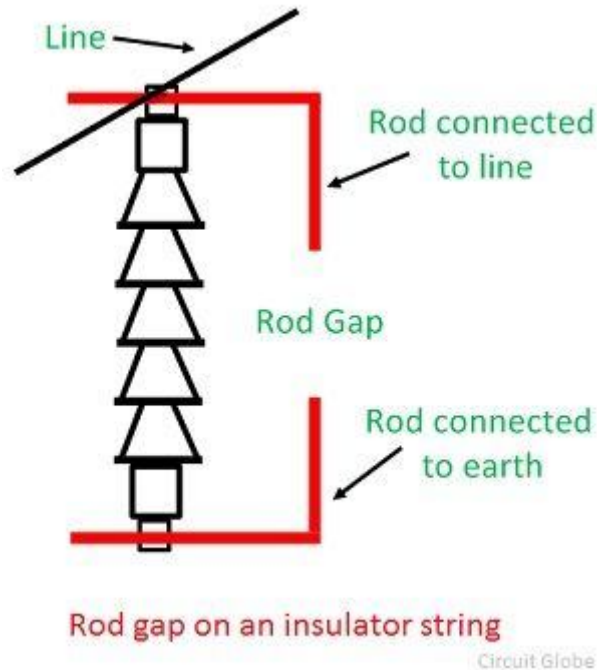

Fig 4.39

The difficulty with the rod arrester is that once the spark having taken place it may continue for some time even at low voltages. To avoid it a current limiting reactor in series with the rod is used. The resistance limits the current to such an extent that it is sufficient to maintain the arc. Another difficulty with the rod gap is that the rod gap is liable to be damaged due to the high temperature of the arc which may cause the rod to melt.

2. Sphere Gap Arrester

In such type of devices, the air gap is provided between two different spheres. One of the spheres is connected to the line, and the other sphere is connected to the ground. The spacing between the two spheres is very small. A choking coil is inserted between the phase winding of the transformer and spheres is connected to the line.

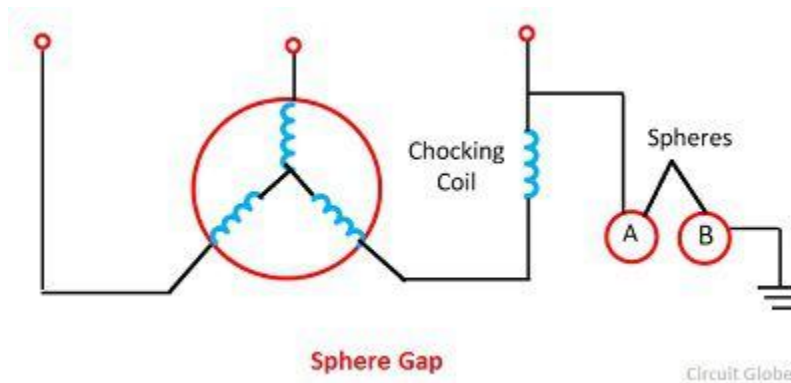
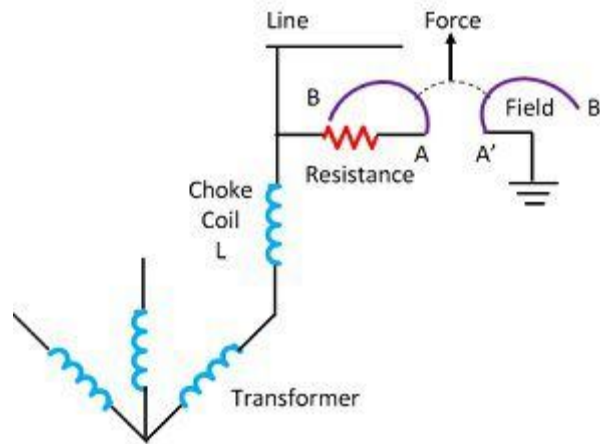

Fig 4.40

The air gap between the arrester is set in such a way so that the discharge must not take place at normal operating condition. The arc will travel up the sphere as the heated air near the arc tend to rise upward and lengthening till it is interrupted automatically.

3. Horn Gap Arrester

It consists of two horns shaded piece of metal separated by a small air gap and connected in shunt between each conductor and earth. The distance between the two electrodes is such that the normal voltage between the line and earth is insufficient to jump the gap. But the abnormal high voltage will break the gap and so find a path to earth.



www.binils.com
Horn Gap With Choke Coil and Resistance
Circuit Globe

Fig 4.41

4. Multiple- Gap Arrester

The multiple gap arrester consists a series of small metal cylinder insulated from one another and separated by an air gap. The first and the last of the series is connected to ground. The number of gaps required depends on the line voltage.

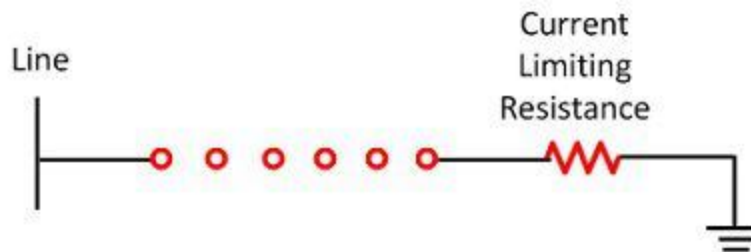

Multiple-Gap Arrester
Circuit Globe

Fig 4.42

5. Impulse Protective Gap

The protective impulse gap is designed to have a low voltage impulse ratio, even less than one and to extinguish the arc. Their working principle is very simple as shown in the figure below. It consists of two sphere electrode S_1 and S_2 which are connected respectively to the line and the arrester.

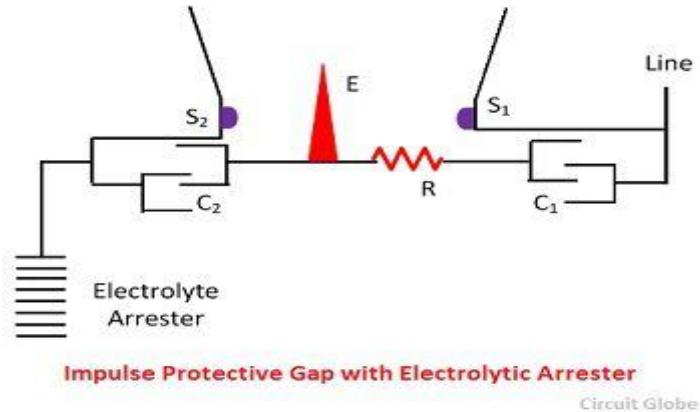

Fig 4.43

The auxiliary needle is placed between the mid of two sphere S_1 and S_2 . At normal frequency, the impedance of the capacitance C_1 is quite large as compared to the impedance of resistor R . If C_1 and C_2 are equal the potential of the auxiliary electrode will be midway between those of the S_1 and S_2 and the electrode has no effect on the flash over between them.

When the transient occurs the impedance of capacitor C_1 and C_2 decrease and the impedance of the resistor now become effective. Due to this, the whole of the voltage is concentrated across the gap between E and S_1 . The gap at once breakdown, the rest of the length between E and S_2 immediately follow.

6. Electrolyte Arrester

In such type of arrester have high a large discharge capacity. It operates on the fact that the thin film of aluminium hydroxide deposits on the aluminium plates immersed in the electrolyte. The plate acts as a high resistance to a low value but a low resistance to a voltage above a critical value.

Voltage more than 400 volts causes a puncture and a free flow of current to earth. When the voltage remains its normal value of 440 volts, the arrester again offers a high resistance in the path and leakage stops.

7. Expulsion Type Lightning Arrester

Expulsion type arrester is an improvement over the rod gap in that it seals the flow of power frequency follows the current. This arrester consists of a tube made up of fibre which is very effective, isolating spark gap and an interrupting spark gap inside the fibre tube.

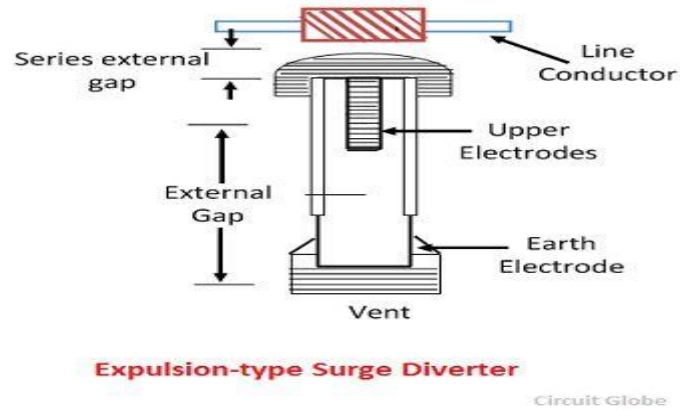

Fig 4.44

During operation, the arc due to the impulse spark over inside the fibrous tube causes some fibrous material of the tube to volatile in the form of the gas, which is expelled through a vent from the bottom of the tube. Thus, extinguishing the arc just like in circuit breakers.

8. Valve Type Lightning Arrester

Such type of resistor is called nonlinear diverter. It essentially consists a divided spark gap in series with a resistance element having the nonlinear characteristic.

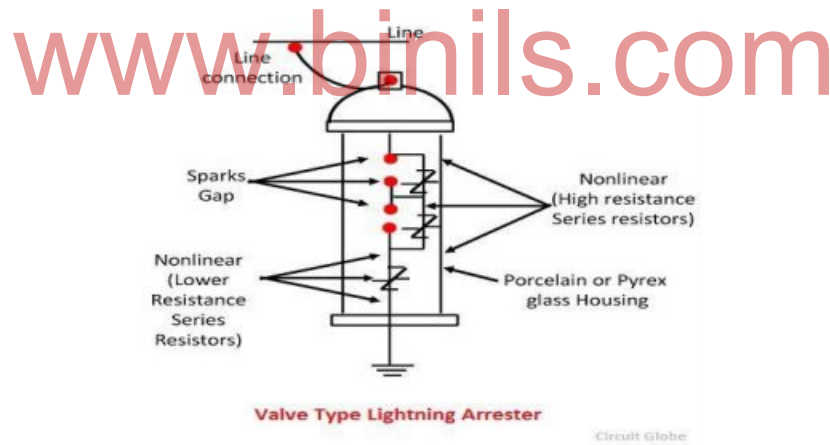

Fig 4.45

The divided spark gap consists of some identical elements coupled in series. Each of them consists two electrodes with the pre-ionization device. Between each element, a grading resistor of high ohmic value is connected in parallel.

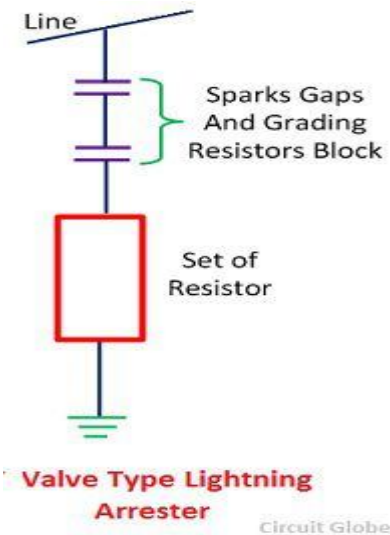

Fig 4.46

During the slow voltage variations, there is no sparks-over across the gap. But when the rapid change in voltage occurs, the potential is no longer evenly graded across the series gap. The influence of unbalancing capacitance between the sparks gaps and the ground prevails over the grounded resistance. The impulse voltage is mainly concentrated on the upper spark gap which in spark over cause the complete arrester to spark over to.

9. Thyrite Lightning Arrester

Such type of arrester is most commonly used for the protection against dangerous high voltage. It consists the thyrite which is an inorganic compound of ceramic material. The resistance of such material decreases rapidly from high value to low value and for current from a low value to high value.

It consists a disc whose both the side is sprayed so as to give the electric contact between the consecutive disc. The disc is assembled inside the glazed porcelain container. It is used in conjunction with the container.

When the lightning takes place, the voltage is raised, and breakdowns of the gaps occur, the resistance falls to a very low value, and the wave is discharged to earth. After the surge has passed the thyrite again come back to its original position.

10 Autovalve Arrester

Such type of arrester consists some flat discs of a porous material stacked one above the other and separated by the thin mica rings. The disc material is not homogenous and conducting material also have been added. Therefore the glow discharge occurs in the capillaries of the material and voltage drop to about 350 volts per unit. The discs are arranged in such a way that normal voltage may not cause a discharge to occur.

11. Oxide Film Arrester

It consists of pellets of lead peroxide with a thin, porous coating of litharge arranged in a column and enclosed in a tube of diameter. Out of the two lead, the upper is connected to the line, while the lower is connected to the earth. The tube contains a series spark gap.

When an overvoltage occurs an arc passes through the series spark gap and an additional voltage is applied to the pellet column and a discharge takes place. After the discharge, the resistance of the pellet gun increases till only very small current flow through it. This small current is finally interrupted by the series spark gaps.

12. Metal Oxide Lightning Arresters/gapless lightning arrester

Such Types of diverter are also known as gapless surge diverters, or Zinc oxide diverter. The base material used for manufacturing metal oxide resistor is zinc oxide. It is a semiconducting N-type material. The material is doped by adding some fine powder of insulating oxides. The powder is treated with some processes and then it is compressed into a disc-shaped. The disc is then enclosed in a porcelain housing filled with nitrogen gas or SF₆.

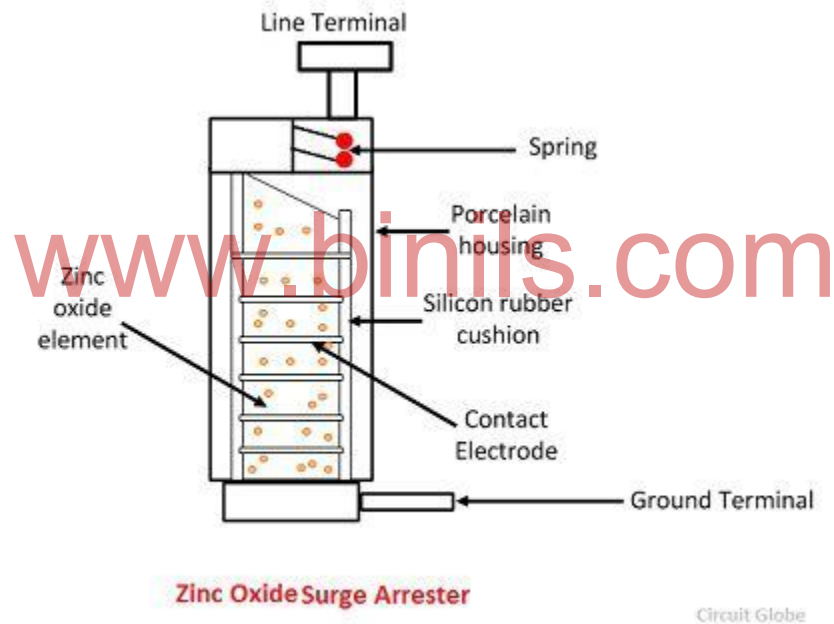

Fig 4.47

This arrester consists a potential barrier at the boundaries of each disc of ZNO. This potential barrier controls the flow of current. At normal operating condition, the potential barrier does not allow the current to flow. When an overvoltage occurs, the barrier collapse and sharp transition from insulating to conducting take place. The current start flowing and the surge is diverted to ground.

REVIEW QUESTION

2MARKS & 3MARKS

1. What is arc voltage?
2. What is the function of switch gear?
3. What is restriking voltage?
4. What is circuit breaker?
5. What is recovery voltage?
6. What is current rating?
7. What is the function of switch gear?
8. What is short time rating?
9. What is function of fuse.
10. What is symmetrical faults in power system?
11. What is un symmetrical faults in power system?
12. What is current rating
13. Explain resistance switching.
14. What is breaking capacity of a circuit breaker?
15. List the various types of circuit breakers.
16. What is voltage surge?
17. What is fusing current?
18. What is meant by lightning?
19. What is making capacity of circuit breakers?
20. What is breaking capacity of circuit breakers?
21. What is capacitance current breaking?
22. State the types of lightning strokes.

10 MARKS

1. Explain the arc phenomenon in circuit breaker.
2. What is merits and demerits of airblast circuit breakers.
3. Explain the working principle of circuit breakers.
4. Explain the essential features of switch gear.
5. Explain the construction and working principle of vacuum circuit breakers?
6. Explain the construction and working principle of cross blast circuit breakers?
7. Explain the construction and working principle of axial blast circuit breakers?
8. Explain the construction and working principle of HRC Fuse with tripping devise?
9. Explain the schematic diagram of HVDC circuit breaker producing current zero.

UNIT -V

PROTECTIVE RELAYS AND GROUNDING

5. PROTECTIVE RELAYS:

Protective relays are the "tools" of the protection engineer. As in any craft, an intimate knowledge of the characteristics and capabilities of the available tools is essential to their most effective use. Therefore, we shall spend some time learning about these tools without too much regard to their eventual use.

5.1 GENERAL CONSIDERATIONS

All the relays that we shall consider operate in response to one or more electrical quantities either to close or to open contacts. We shall not bother with the details of actual mechanical construction except where it may be necessary for a clear understanding of the operation. One of the things that tend to dismay the novice is the great variation in appearance and types of relays, but actually there are surprisingly few fundamental differences. Our attention will be directed to the response of the few basic types to the electrical quantities that actuate them.

5.1.1 OPERATING PRINCIPLES

There are really only two fundamentally different operating principles: (1) electromagnetic attraction, and (2) electromagnetic induction. Electromagnetic attraction relays operate by virtue of a plunger being drawn into a solenoid, or an armature being attracted to the poles of an electromagnet. Such relays may be actuated by d-c or by a-c quantities. Electromagnetic-induction relays use the principle of the induction motor whereby torque is developed by induction in a rotor; this operating principle applies only to relays actuated by alternating current, and in dealing with those relays we shall call them simply "induction-type" relays.

5.1.2 Fundamental requirements of protective relaying

The principal function of protective relaying is to cause the prompt removal from service of any element of the power system when it starts to operate in an abnormal manner or interfere with the effective operation of the rest of the system.

In order that protective relay system may perform this function satisfactorily, it should have the following qualities:

1. Selectivity
2. Speed
3. Sensitivity
4. Reliability
5. Simplicity
6. Economy

Selectivity

It is the ability of the protective system to select correctly that part of the system in trouble and disconnect the faulty part without disturbing the rest of the system.

- A well designed and efficient relay system should be selective i.e. it should be able to detect the point at which the fault occurs and cause the opening of the circuit breakers closest to the fault with minimum or no damage to the system.

This can be illustrated by referring to the single line diagram of a portion of a typical power system shown in figure below. It may be seen that circuit breakers are located in the connections to each power system element in order to make it possible to disconnect only the faulty section.

If a fault occurs at bus-bars on the last zone, then only breakers nearest to the fault viz. 10, 11, 12 and 13 should open. In fact, opening of any other breaker to clear the fault will lead to a greater part of the system being disconnected.

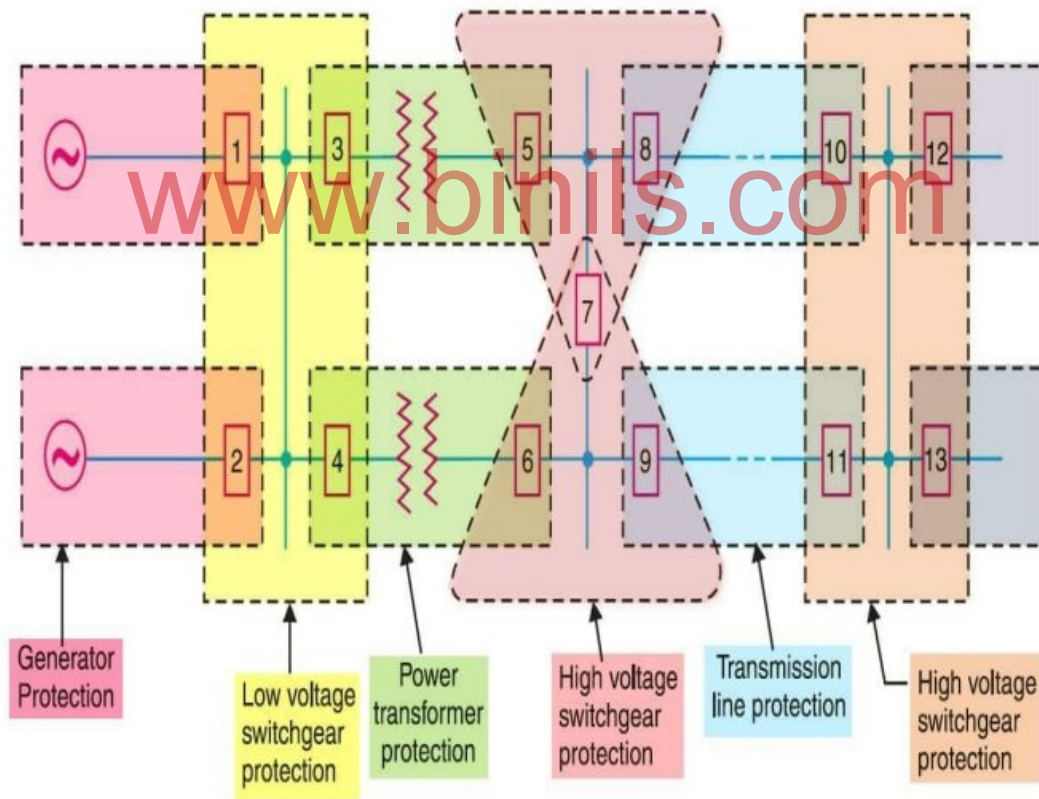

Fig 5. 1

Single Line Diagram of a portion of Power System

In order to provide selectivity to the system, it is a usual practice to divide the entire system into several protection zones. When a fault occurs in a given zone, then only the circuit breakers within that zone will be opened. This will isolate only the faulty circuit or apparatus, leaving the healthy circuits intact.

The system can be divided into the following protection zones :

- (a) generators
- (b) low-tension switchgear
- (c) transformers
- (d) high-tension switchgear
- (e) transmission lines

It may be seen in above figure that there is certain amount of overlap between the adjacent protection zones. For a failure within the region where two adjacent zones overlap, more breakers will be opened than the minimum necessary to disconnect the faulty section.

But if there were no overlap, a failure in the region between zones would not lie in either region and, therefore, no breaker would be opened. For this reason, a certain amount of overlap is provided between the adjacent zones.

Speed

The relay system should disconnect the faulty section as fast as possible for the following reasons :

- Electrical apparatus may be damaged if they are made to carry the fault currents for a long time.
- A failure on the system leads to a great reduction in the system voltage. If the faulty section is not disconnected quickly, then the low voltage created by the fault may shut down consumers motors and the generators on the system may become unstable.
- The high speed relay system decreases the possibility of development of one type of fault into the other more severe type.

The ultimate goal of protective relaying is to disconnect a faulty system element as quickly as possible. Sensitivity and selectivity are essential to assure that the proper circuit breakers will be tripped, but speed is the 'pay-off'.

Sensitivity

It is the ability of the relay system to operate with low value of actuating quantity.

Sensitivity of a relay is a function of the volt-amperes input to the coil of the relay necessary to cause its operation.

- The smaller the volt-ampere input required to cause relay operation, the more sensitive is the relay.

Thus, a 1 VA relay is more sensitive than a 3 VA relay. It is desirable that relay system should be sensitive so that it operates with low values of volt-ampere input.

Reliability

It is the ability of the relay system to operate under the pre-determined conditions. Without reliability, the protection would be rendered largely ineffective and could even become a liability.

That protective-relaying equipment must be reliable is a basic requirement. When protective relaying fails to function properly, the allied mitigation features are largely ineffective. Therefore, it is essential that protective-relaying equipment be inherently reliable, and that its application, installation, and maintenance be such as to assure that its maximum capabilities will be realized.

Simplicity

The relaying system should be simple so that it can be easily maintained. Reliability is closely related to simplicity. *The simpler the protection scheme, the greater will be its reliability.*

Economy

The most important factor in the choice of a particular protection scheme is the economic aspect. Sometimes it is economically unjustified to use an ideal scheme of protection and a compromise method has to be adopted.

- *As a rule, the protective gear should not cost more than 5% of total cost.*

However, when the apparatus to be protected is of utmost importance (e.g. generator, main transmission line etc.), economic considerations are often subordinated to reliability.

5.2 Primary and Back-up Protection

Primary protection (Main protection) is the essential protection provided for protecting an equivalent/machine or a part of the power system. As a precautionary measure, an additional protection is generally provided and is called '*Backup Protection*'.

How Protective Relays Work?

If any fault occurs in the protected area, the primary protection act first. If primary protection fails to act, the **back-up protection** comes into action and removes the faulty part from the healthy system.

5.2.1 Advantages of Back-up Protection

Back-up protection is provided for the following reasons

- If due to some reason, the **Main protection** fails, the Back-up protection serves the purpose of protection.
 - **Main protection** can fail due to failure of one of the components in the protective system such as relay, auxiliary relay CT, PT, trip circuit, circuit-breaker, etc. If the **primary protection** fails, there must be an additional protection, otherwise the fault may remain uncleared, resulting in a disaster.

- When main protection is made inoperative for the purpose of maintenance, testing, etc. the **Back-up protection** acts like main protection.
 - As a measure of economy, **Back-up protection** is given against short-circuit protection and generally not for other abnormal conditions. The extent to which back-up protection is provided, depends upon economic and technical considerations,
 - The cost of **back-up protection** is justified on the basis of probability of failure of individual component in protection system, cost of the protected equipment, importance of protected equipment, location of protected equipment, etc.

5.2.2 Methods of Back-up Protection

The **methods of back-up protection** can be classified as follows :

1. Relay Back-up
2. Breaker Back-up
3. Remote back-up
4. Centrally Coordinated Back-up

Relay Back-up

Same breaker is used by both **main** and **back-up protection**, but the protective systems are different. Separate trip coils may be provided for the same breaker.

Breaker Back-up

Different breakers are provided for **main** and **back-up protection**, both the breakers being in the same station

Remote back-up

The **main** and **back-up protections** provided at different stations and are completely independent.

Centrally Coordinated Back-up

The system having central control can be provided with centrally controlled back-up. Central control continuously supervises the load flow and frequency in the system. The information about load flow and frequency is assessed continuously.

If one of the components in any part of the-system fails, (e.g. a fault on a transformer, in some station) the load flow in the system is affected. The central coordinating station receives information about the abnormal condition through high frequency carrier signals.

The stored programme in the digital computer determines the correct switching operation, as regards severity of fault, system stability,

Back up Protection by Time Grading Principle

The current is measured at various points along the current path, e.g., at source, intermediate locations, consumer end. The tripping time at these locations are graded in such a way that the circuit-breaker/fuse nearest the faulty part operate first, giving primary protection. The circuit breaker/fuse at the previous station operates only as **back-up**.

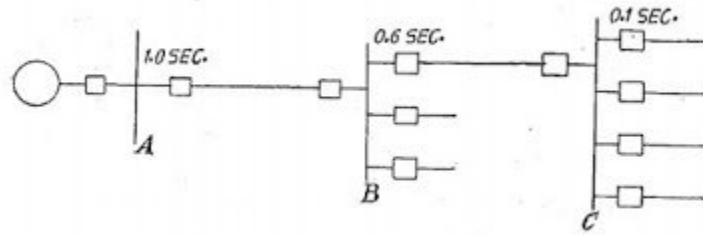

Fig 5. 2

Referring to figure, the tripping time at station C, B and A are graded such that for a fault beyond C breaker at C operates as a primary protection. Meanwhile, the relays at A and B also may start operating but they are provided with enough time lag so that the circuit-breaker at B operates only if the circuit-breaker at C does not.

Relay timing.

An important characteristic of a relay is its time of operation. By 'the time of operation' is meant length of the time from the instant when the actuating element is energised to the instant when the relay contacts are closed. Sometimes it is desirable and necessary to control the operating time of a relay. For this purpose, mechanical accessories are used with relays.

5.3 Instantaneous Relay

Definition

An instantaneous relay is one in which there is no time delay provided intentionally. More specifically ideally there is no time required to operate the relay. Although there is some time delay which can not be avoided.

As the current coil is an inductor, there would be a certain delay to reach the current in the coil to its maximum value. There is also some time required for mechanical movement plunger in the relay. These time delays are inherent in the instantaneous relay but no other time delay is intentionally added. These relays can be operated in less than 0.1 sec.



Fig 5. 3

Example

There are various types of relay which can be considered as instantaneous relay. Such as, attracted armature relay where an iron plunger is attracted by an electro-magnet to actuate the relay. When attractive force of the electro-magnet crosses its pick up level, the iron plunger starts move towards the magnet and crosses the relay contacts. The magnetic strength of the electromagnet, depends upon the current flows the coil conductors.

Another popular example of instantaneous relay, is solenoid type relay. When current in the solenoid crosses pick up value, the solenoid attracts an iron plunger which moves to close the relay contacts.

Inverse Time Relay

In this type of relays, the time of operation depends upon the magnitude of actuating quantity. If the magnitude of actuating quantity is very high, the relay operation is very fast. In other words, the relay operating time that is time delay in the relay is inversely proportional to the magnitude of actuating quantity. The general characteristics of an inverse time relay is shown in figure below.

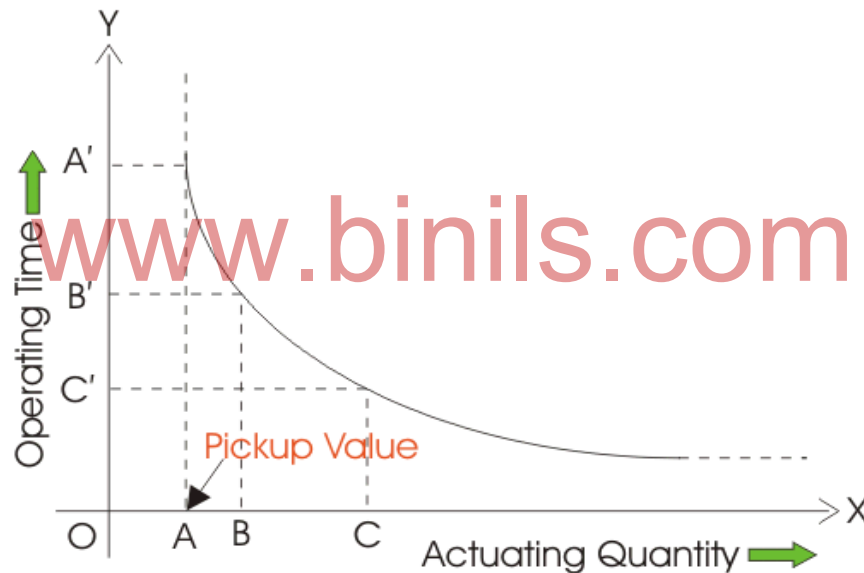

Fig 5. 4

Here, in the graph it is clear that, when, actuating quantity is OA, the operating time of the relay is OA', when actuating quantity is OB, the relay operating time is OB' and when actuating quantity is OC, the relay operating quantity is OC'.

In the graph above, it is also observed that, when actuating quantity is less than OA, the relay operating time becomes infinity, that means for actuating quantity less than OA, the relay does not at all actuate. This minimum value of actuating quantity for which a relay initiates its operation is known as pick up value of actuating quantity. Here it is denoted as OA. It is also seen from the graph that, when actuating quantity approaches to infinity along x axis the operating time does not approach to zero. The

curve approaches to an approximately constant operating time. This is approximately minimum time required to operate the relay.

“The inverse time relay, where the actuating quantity is current, is known as inverse current relay. “

In this type of relay, the inverse time is achieved by attaching some mechanical accessories in the relay. Inverse time delay is achieved in induction disc relay by providing a permanent magnet in such a way, that, when disc rotates, it cuts the flux of permanent magnet. Due to this, current is induced in the disc which slows down the movement of the disc. A solenoid relay can be made **inverse time relay**, by providing a piston and a oil dash-pot. A piston, attached to the moving iron plunger, is immersed in oil in a dash-pot. When the solenoid relay is actuated, the piston moves upwards along with iron plunger. Viscosity of oil slows the upward movement of plunger. The speed of this upward movement against gravity also depends upon how strongly the solenoid attracts the iron plunger. This attraction force of the solenoid depends upon the magnitude of actuating current. Hence, time of operation of relay is inversely proportional to actuating current.

Definite Time Lag Relay

During relay coordination in electrical power system protection scheme, there is some time intentionally required, to operate some specific relays after some specific time delays. Definite time lag relays are those which operate after a specific time. The time lag between instant when the actuating current crosses the pickup level and the instant when relay contacts finally closed, is constant. This delay does not depend up on magnitude of actuating quantity. For all actuating quantity, above pick up values, the relay operating time is constant.

Inverse definite minimum time

IDMT relays are protection relays. They are used on transmission lines to see to that the line current doesn't exceed safe values and if it does, triggers the circuit breaker. IDMT means **inverse definite minimum time**. So as the current keeps increases, the relay takes **minimum time** to trip the circuit.

Inverse means "higher the current value, lesser the time taken for the relay to trip the circuit". Current in the line and the time taken for the relay to trip the CB follow an inverse proportionality.

5.4 OVER LOAD INVERSE-TIME / INVERSE DEFINITE MINIMUM TIMELAG (I.D.M.T.) RELAY

The over load inverse time relay is shown in fig 5.5. It consists of an upper electromagnet that has been provided with two windings one primary and the other secondary. Primary is connected to a current transformer in the line which is under protection and is provided with eight tappings. These tappings are connected to a plug setting bridge by which the number of turns to be used can be adjusted in order to have the desired current setting. The second winding called secondary is energized by the induction effect and is wound over the central limb of the upper magnet as well as it is spread over the two limbs of the lower magnet. By this method, the leakage flux from the upper magnet entering the disc has been

displaced in phase from the flux entering the disc from the lower magnet. The deflecting torque is produced on the disc in the fashion as already explained. The spindle of the disc carries a moving contact which bridges two fixed contacts after the disc has rotated through a certain angle which has been set before. Any setting for this angle is possible varying from 0 to 360°. The variation of this angle imparts to the relay, various time settings.

The speed of rotation of the disc is dependent upon the torque which in turn is dependent on the current setting, when the load current increases from this setting it will increase the speed of rotation of the disc resulting into decrease of operation time. Thus the time current characteristics of the relay observe inverse-Square law. The definite minimum time characteristics of the relay are obtained by the use of a saturated upper magnet. This ensures that there is no further increase in flux when the current has reached a certain value and any further increase of current will not affect the relay operation. This results in a flattened current time characteristic and the relay obtains its name as **Inverse definite minimum time lag (I.D.M.T.) relay**

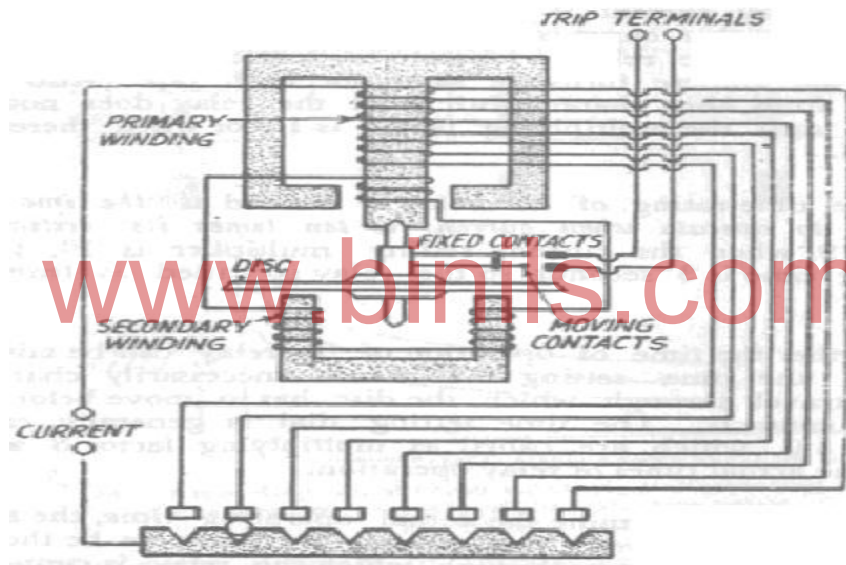

fig 26

Fig 5. 5

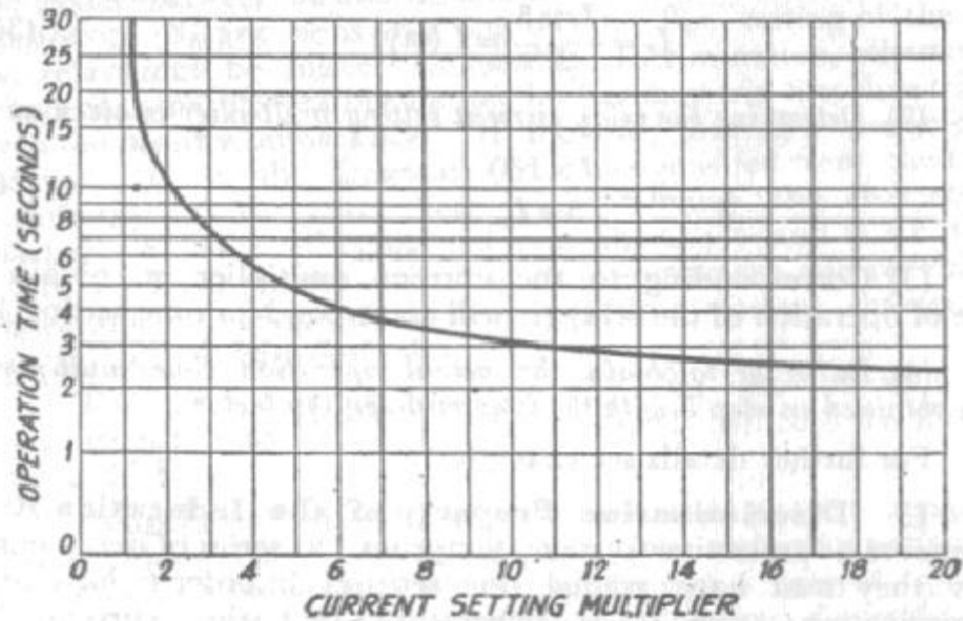

fig 27

Fig 5. 6

The current time characteristics of the relay have been illustrated in Fig. 5.6. It represents the time required to close the trip contacts for different values of over current. Its horizontal scale is marked in terms of current-setting multipliers i.e. number of times the relay current is in excess of current setting

5.5 CLASSIFICATION OF RELAYS

Based on Characteristic the protection relay can be categorized as-

1. **Definite time relays**
2. **Inverse time relays with definite minimum time(IDMT)**
3. **Instantaneous relays.**
4. **IDMT with inst.**
5. **Stepped characteristic.**
6. **Programmed switches.**
7. **Voltage restraint over current relay.**

Based on of logic the protection relay can be categorized as-

1. Differential.
2. Unbalance.
3. Neutral displacement.
4. Directional.
5. Restricted earth fault.

6. Over fluxing.
7. Distance schemes.
8. Bus bar protection.
9. Reverse power relays.
10. Loss of excitation.
11. Negative phase sequence relays etc.

Based on actuating parameter the protection relay can be categorized as-

1. Current relays.
2. Voltage relays.
3. Frequency relays.
4. Power relays etc.

Based on application the protection relay can be categorized as-

1. Primary relay.
2. Backup relay.

Primary relay or primary protection relay is the first line of power system protection whereas backup relay is operated only when primary relay fails to be operated during fault. Hence backup relay is slower in action than primary relay. Any relay may fail to be operated due to any of the following reasons,

1. The protective relay itself is defective.
2. DC Trip voltage supply to the relay is unavailable.
3. Trip lead from relay panel to circuit breaker is disconnected.
4. Trip coil in the circuit breaker is disconnected or defective.
5. Current or voltage signals from CT or PT respectively is unavailable.

As because backup relay operates only when primary relay fails, backup protection relay should not have anything common with primary protection relay. Some examples of Mechanical Relay are-

1. **Thermal**
 - o OT trip (Oil Temperature Trip)
 - o WT trip (Winding Temperature Trip)
 - o Bearing temp trip etc.
2. **Float type**
 - o Buchholz
 - o OSR
 - o PRV
 - o Water level Controls etc.
3. **Pressure switches.**
4. **Mechanical interlocks.**
5. **Pole discrepancy relay.**

5.6 INDUCTION TYPE DIRECTIONAL OVER CURRENT RELAY

The directional power relay is not suitable under short circuit conditions because as short circuit occurs the system voltage falls to a low value resulting in insufficient torque to cause relay operations. This difficulty is overcome in the directional over current relay, which is independent of system voltage and power factor.

Constructional details:

Figure 5.7 shows the constructional details of a typical induction type directional over current relay. It consists of two relay elements mounted on a common case viz. (i) directional element and (ii) non-directional element.

(i) Directional element:

It is essentially a directional power relay, which operates when power flows in a specific direction. The potential of this element is connected through a potential transformer (PT.) to the system voltage. The current coil of the element is energized through a CT by the circuit current. This winding is carried over the upper magnet of the non-directional element. The trip contacts (1 and 2) of the directional element are connected in series with secondary circuit of the over current element. The latter element cannot start to operate until its secondary circuit is completed. In other words, the directional element must first operate (ie. contacts 1 and 2 should close) in order to operate the over current element.

(ii) Non-directional element:

It is an over current element similar in all respects to a non-directional over current relay. The spindle of the disc of this element carries a moving contact which closes the fixed contact after the operation of directional element. Plug setting bridge is provided for current setting. The tapings are provided on the upper magnet of over current element and are connected to the bridge.

Operation:-

Under normal operating conditions, power flows in the normal direction in the circuit operated by the relay. Therefore, directional power relay does not operate, thereby keeping the (lower element) un-energized. However, when a short circuit occurs, there is a tendency for the current or power to flow in the reverse direction. The disc of the upper element rotates to bridge the fixed contacts 1 and 2. This completes the circuit for over current element.

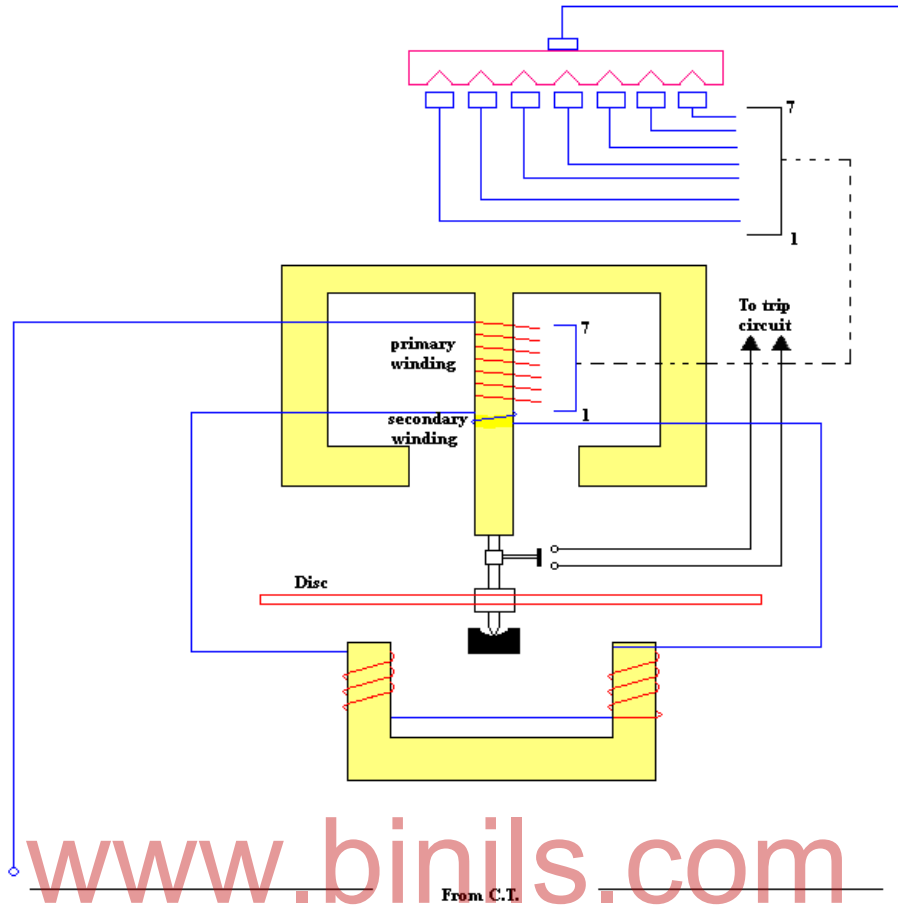

Fig 5. 7

The disc of this element rotates and the moving contact attached to it closes the trip circuit. This operates the circuit breaker which isolates the faulty section

5.7 INDUCTION TYPE DIRECTIONAL POWER RELAY

The step of relay operates when the power in the circuit flows, in a specific direction. A **directional power relay** is so designed that it obtains its operating torque by the interaction of magnetic field derived from both voltage and current source of the circuit it protects. The direction of torque depends upon the current relative to voltage.

Constructional Details

Figure shows the essential parts of a typical **induction type directional power relay**. It consists of an aluminum disc, which is free to rotate in between the poles of two electromagnet. The upper electromagnet carries a winding called potential coil on the central limb, which is connected through a potential transformer (PT.) to the circuit voltage source. The lower electromagnet has a separate winding called current coil connected to the secondary of CT. in the line to be protected.. The current coil

is provided with a number of tapings connected to the plug setting bridge. This permits to have any desired current setting. The restraining torque is provided by a spiral spring. The spindle of the disc carries a moving contact which bridges two fixed contacts when the disc has rotated through a preset angle. By adjusting this angle, desired time setting can be obtained.

Operation:-

The flux ϕ_1 due to current in the potential coil will be nearly 90° lagging behind the applied voltage V. The flux ϕ_2 due to current coil will be nearly in phase with the operating current I, as in the

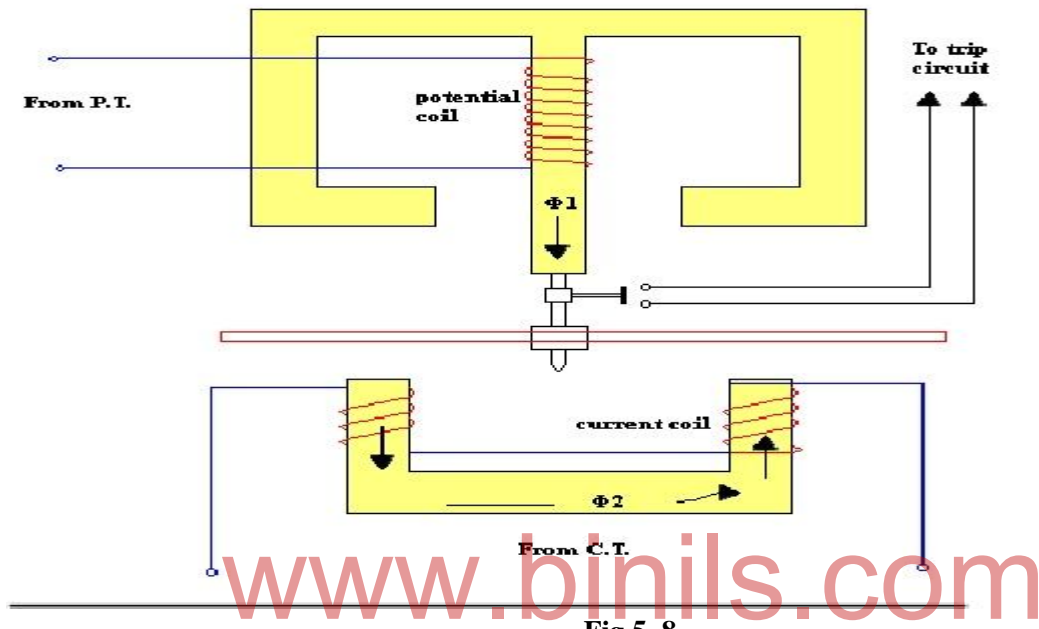

Fig 5. 8

vector diagram. The interaction of fluxes ϕ_1 and ϕ_2 with the eddy currents induced in the disc produces a driving torque given by:

$$T \propto \phi_1 \phi_2 \sin \alpha.$$

$$\phi_1 \propto V, \phi_2 \propto I \text{ and } \alpha = 90 - \theta$$

$$\propto VI \sin (90 - \theta)$$

$$\propto VI \cos \theta$$

Power in the circuit

It is clear, that the direction of driving torque on the disc depends on the direction of power flow in the circuit to which the relay is associated. When the power in the circuit flows in the normal direction the driving torque and the restraining torque help each other to turn away the moving contact from the fixed contacts. Thus the relay remains in operative. But with reversal of current in

the circuit the direction of driving torque on the disc reverses. When the reversed driving torque is large enough, the disc rotates in reverse direction, and then the moving contact closes the trip circuit

Distance or Impedance Relays

The operation of the relays discussed so far depended upon the magnitude of current or power in the protected circuit. However, there is another group of relays in which the operation is governed by the ratio of applied voltage to current in the protected circuit. Such relays are called distance or impedance relays. In an impedance relay, the torque produced by a current element is opposed by the torque produced by a voltage element. The relay will operate when the ratio V/I is less than a predetermined value.

Fig. 5.8 illustrates the basic principle of operation of an impedance relay. The voltage element of the relay is excited through a potential transformer (P.T.) from the line to be protected. The current element of the relay is excited from a current transformer (C.T.) in series with the line. The portion AB of the line is the protected zone. Under normal operating conditions, the impedance of the protected zone is Z_L . The relay is so designed that it closes its contacts whenever impedance of the protected section falls below the pre-determined value *i.e.* Z_L in this case.

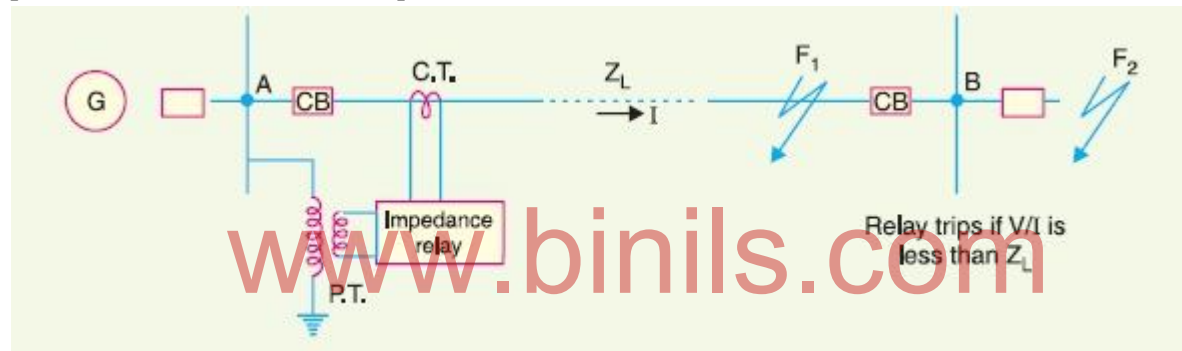

Fig 5. 9

Now suppose a fault occurs at point F_1 in the protected zone. The impedance $Z (= V/I)$ between the point where the relay is installed and the point of fault will be less than Z_L and hence the relay operates. Should the fault occur beyond the protected zone (say point F_2), the impedance Z will be greater than Z_L and the relay does not operate.

Types.

A distance or impedance relay is essentially an ohmmeter and operates whenever the Impedance of the protected zone falls below a pre-determined value. There are two types of distance relays in use for the protection of power supply, namely ;

(i) **Definite-distance relay** which operates instantaneously for fault upto a pre-determined distance from the relay.

(ii) **Time-distance relay** in which the time of operation is proportional to the distance of fault from the relay point. A fault nearer to the relay will operate it earlier than a fault farther away from the relay. It may be added here that the distance relays are produced by modifying either of two types of basic relays; the balance beam or the induction disc.

5.8 Definite – Distance Type Impedance Relay

Fig. 5.10 shows the schematic arrangement of a definite-distance type impedance relay. It consists of a pivoted beam F and two electromagnets energised respectively by a current and voltage transformer in the protected circuit. The armatures of the two electromagnets are mechanically coupled to the beam on the opposite sides of the fulcrum. The beam is provided with a bridging piece for the trip contacts. The relay is so designed that the torques produced by the two electromagnets are in the opposite direction.

Operation

Under normal operating conditions, the pull due to the voltage element is greater than that of the current element. Therefore, the relay contacts remain open. However, when a fault occurs in the protected zone, the applied voltage to the relay decreases whereas the current increases. The ratio of voltage to current (*i.e.* impedance) falls below the pre-determined value. Therefore, the

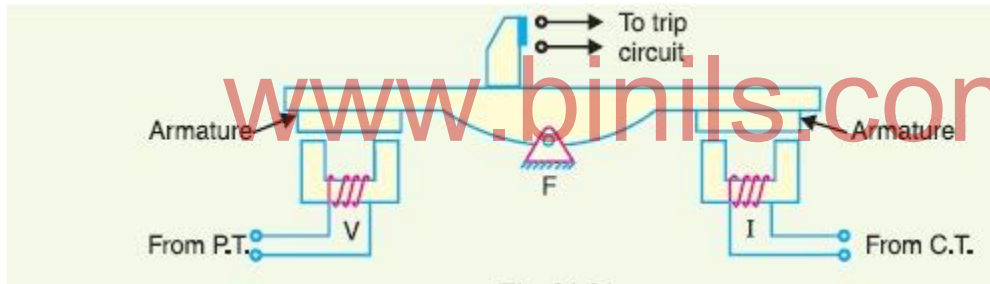

Fig 5. 10

pull of the current element will exceed that due to the voltage element and this causes the beam to tilt in a direction to close the trip contacts. The pull of the current element is proportional to I^2 and that of voltage element to V^2 . Consequently, the relay will operate when

$$k_1 V^2 < k_2 I^2$$

or

$$\frac{V^2}{I^2} < \frac{k_2}{k_1}$$

or

$$\frac{V}{I} < \sqrt{\frac{k_2}{k_1}}$$

or

$$Z < \sqrt{\frac{k_2}{k_1}}$$

The value of the constants k_1 and k_2 depends upon the ampere-turns of the two electromagnets.

By providing tapings on the coils, the setting value of the relay can be changed.

Time-Distance Impedance Relay

A time-distance impedance relay is one which automatically adjusts its operating time according to the distance of the relay from the fault point *i.e.*

$$\begin{aligned}\text{Operating time,} \quad T &\propto V/I \\ &\propto Z \\ &\propto \text{Distance}\end{aligned}$$

Construction

Fig shows the schematic arrangement of a typical induction type time distance impedance relay. It consists of a current driven induction element similar to the double winding type induction over current relay (refer back to Fig. 5.11). The spindle carrying the disc of this element is connected by means of a spiral spring coupling to a second spindle which carries the bridging piece of the relay trip contacts. The bridge is normally held in the open position by an armature held against the pole face of an electromagnet excited by the voltage of the circuit to be protected.

www.binils.com

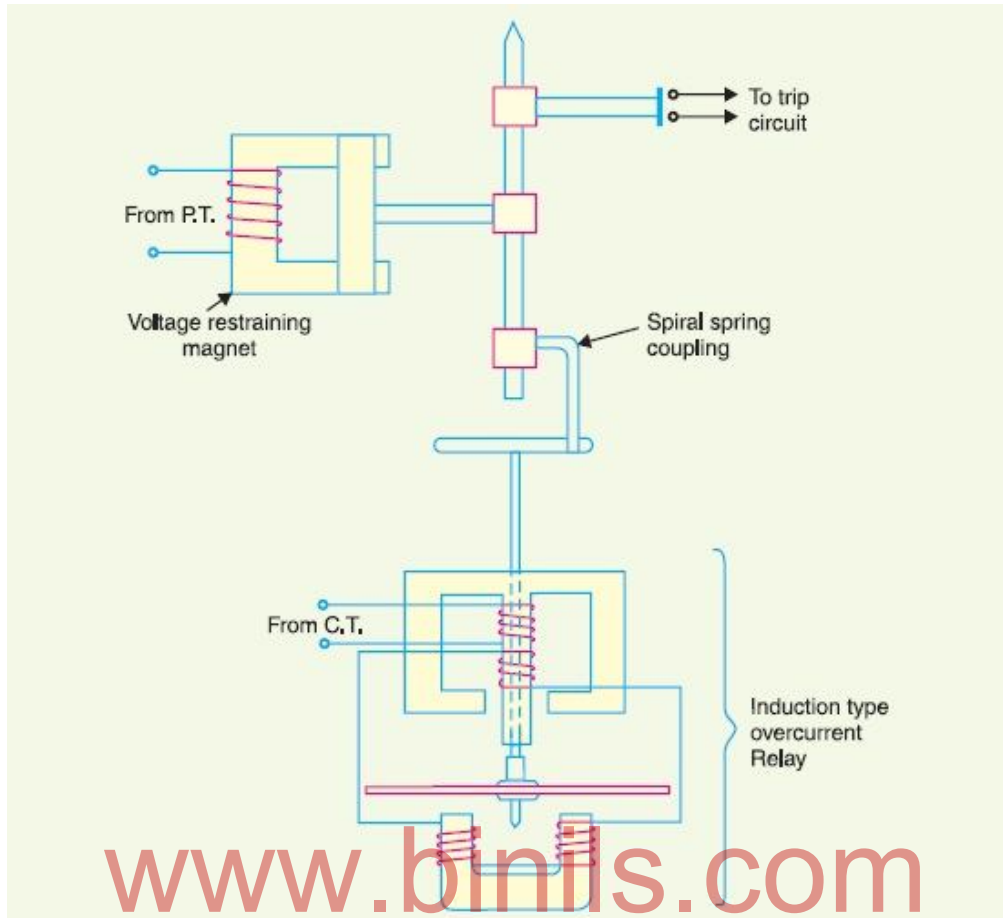

Fig 5. 11

Operation

Under normal load conditions, the pull of the armature is more than that of the induction element and hence the trip circuit contacts remain open. However, on the occurrence of a short-circuit, the disc of the induction current element starts to rotate at a speed depending upon the operating current. As the rotation of the disc proceeds, the spiral spring coupling is wound up till the tension of the spring is sufficient to pull the armature away from the pole face of the voltage-excited magnet. Immediately this occurs, the spindle carrying the armature and bridging piece moves rapidly in response to the tension of the spring and trip contacts are closed. This opens the circuit breaker to isolate the faulty section.

The speed of rotation of the disc is approximately proportional to the operating current, neglecting the effect of control spring. Also the time of operation of the relay is directly proportional to the pull of the voltage-excited magnet and hence to the line voltage V at the point where the relay is connected. Therefore, the time of operation of relay would vary as V/I i.e. as Z or distance.

5.9 Differential Protection Relay

A differential relay is defined as the relay that operates when the phase difference of two or more identical electrical quantities exceeds a predetermined amount. The differential relay works on the principle of comparison between the phase angle and magnitude of two or more similar electrical quantities. Comparing two electrical quantities in a circuit using differential relays is simple in application and positive in action.

For example, consider the comparison of the current entering a protected line and the current leaving it. If the current entering the protected line is more than the current leaving it, then the extra current must flow in the fault. The difference between the two electrical quantities can operate a relay to isolate the circuit.

For the operation of the differential relay, it should have two or more electrical quantities, and these quantities should have a phase displacement (normally approximately 180). Any types of the relay can operate as a differential relay depends on upon the way it is connected in a circuit. In other words, it doesn't depend on the construction of the relay it depends on the way it is connected to the circuit.

Differential protection provides unit protection. The protected zone is exactly known by the location of current and potential transformers. The phase difference is achieved by suitable connections of secondary's of CTs and PTs.

The differential protection principle is employed for the protection of generator, generator-transformer units, transformers, feeders, large motors, and bus-bars. The differential protection relay is mainly classified into four categories. These are

- *Current Differential Relay*
- *Voltage Differential Relay*
- *Biased or Percentage Differential Relay*
- *Voltage Balance Differential Relay*

5.9.1 Current Differential Relay

A relay which senses and operates the phase difference between the current entering into the electrical system and the current leaving the electrical system is called a current differential relay. An arrangement of over current relay connected to operate as a differential relay is shown in the figure below.

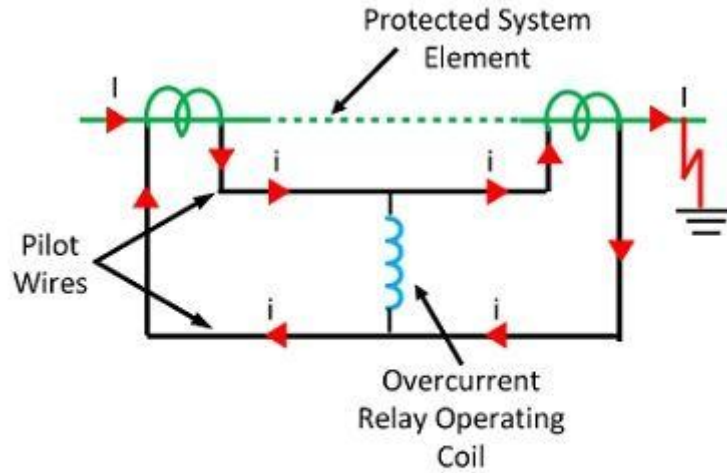

For an External Load or Fault

Circuit Globe

Fig 5. 12

The dotted line represents the element of the system that is to be protected by the differential relay. The system element might be a length of the circuit, a portion of the bus or a winding of a generator or that of a transformer. A pair of current transformers is fitted on the either ends of the section to be protected. The secondaries of current transformers are connected in series with the help of the pilot wires in such a way that they carry the induced current in the same direction. The operating coil of an overcurrent relay is connected across the current transformer secondary circuit shown in the figure below.

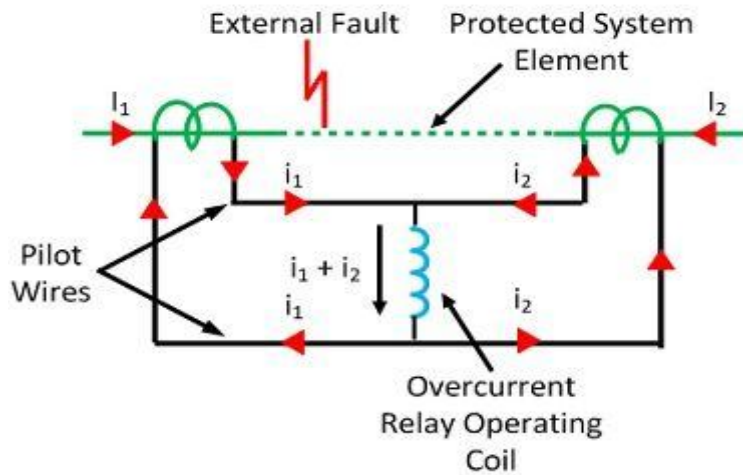

For an Internal Fault

Circuit Globe

Fig 5. 13

When there is no fault current or there is an external fault, then the current in the secondaries of the current transformers are equal, and the relay operating coil, therefore, does not carry any current.

When the short circuit developed anywhere between the two current transformers, then the currents flow to the fault of both sides, and the sum of the current transformer secondary current will flow through the differential relay.

5.9.2 Biased or Percentage Differential Coil

This is the most used form of differential relay. Their arrangement is same as that of the current differential relay; the only difference is that this system consists an additional restraining coil connected in the pilot wires as shown in the figure below and current flows in both CTs flows through it.

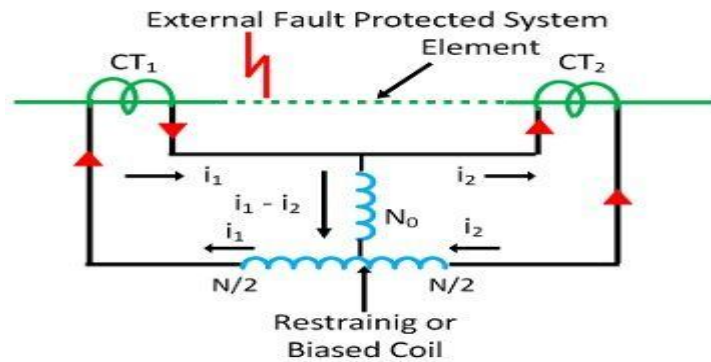

Biased or Percentage Differential Relay
Circuit Globe
www.binils.com
Fig 5. 14

The operating coil is connected to the midpoint of the restraining coil. The reasons for this modification in circulating current differential relay are to overcome the difficulty arising out of differences in current transformers ratio for high values of short circuit current.

5.9.3 Induction Type Biased Differential Relay

This relay consists of a pivoted disc free to rotate in the air gaps of two electromagnets. The portion of each pole of the electromagnet magnet is fitted with a copper shading ring. The ring can be moved further in, or out of the pole. The disc experiences two torques one due to operating element and other due to restraining element.

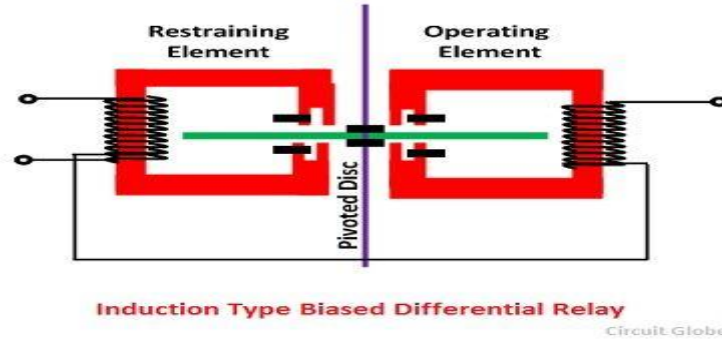
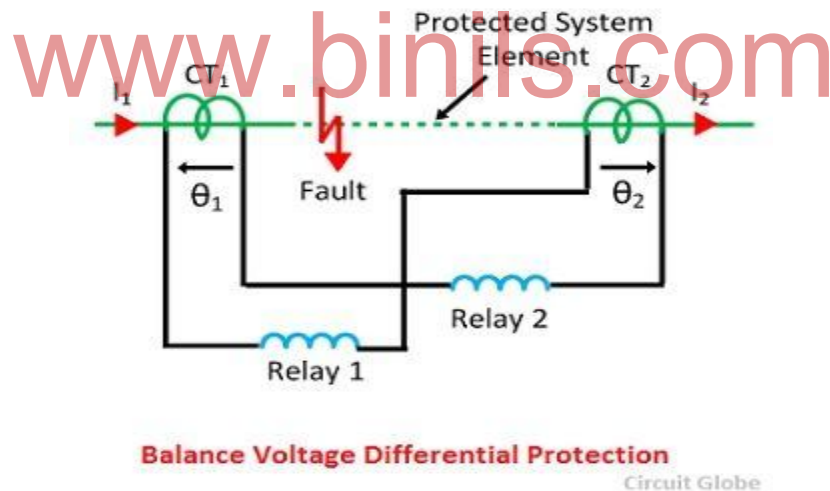

Fig 5. 15

If the shading rings were in the position on each element, then the resulting torque experienced by the disc would be zero. But if the shading rings of restraining element were moved further into the iron core, the torque exerted by the restraining element will exceed than that of the operating element.

5.9.4 Voltage Balance Differential Relay

The current differential relay is not suitable for the protection of the feeders. For the protections of the feeders, the voltage balance differential relays are used. In this arrangement, the two similar current transformers are connected at either end of the system element under protection using pilot wires.



The relays are connected in series with the pilot wires, one at each end. The relative polarity of the current transformers is such that there is no current through the relay under normal operating conditions and under fault conditions. The CTs used in such protections should be such that they should induce voltages in the secondary linearly with respect to the current. Since the magnitude of the fault current is very large, so that the voltage should be a linear function of such large currents, the CTs should be aird cored.

When the fault occurs in the protected zone, the currents in the two primaries will differ from one another, and so voltage induced in the secondaries of the CTs will differ and circulating current will flow

through the operating coils of the relays. Thus the trip circuit will be closed, and the circuit breaker will be open.

5.9.5 Negative Sequence Relay

Definition:

A relay which protects the electrical system from negative sequence component is called a negative sequence relay or unbalance phase relay. A negative phase sequence or unbalance relay is essentially provided for the protection of generators and motors against unbalanced loading that may arise due to phase-to-phase faults.

Induction type Negative Sequence Relay

The construction of induction type negative phase sequence relay is similar as that of an induction type over current relay. This relay consists of a metallic disc usually made up of an aluminum coil, and this is rotating between two electromagnets the upper and the lower electromagnets.

The upper electromagnet has two winding, the primary winding of the upper electromagnet is connected to the secondary of the CT connected in the line to be protected. The secondary winding of the upper electromagnet is connected in series with the windings on the lower electromagnet

The primary windings provided on the central limb of the upper electromagnet which is provided by the central tap resulting into three terminals 1, 2, and 3 of these windings. The upper half is energized from phase R through CT and an auxiliary transformer while the lower half is energized from phase Y through CT. The auxiliary transformer has a special construction such that the output of this transformer lag by 120° instead of 180° .

5.10 Earth-Fault or Leakage Protection

An earth-fault usually involves a partial breakdown of winding insulation to earth. The resulting leakage current is considerably less than the short-circuit current. The earth-fault may continue for a long time and cause considerable damage before it ultimately develops into a short-circuit and removed from the system. Under these circumstances, it is profitable to employ earth-fault relays in order to ensure the disconnection of earth-fault or leak in the early stage. An earth-fault relay is essentially an overcurrent relay of low setting and operates as soon as an earth-fault or leak develops. One method of protection

against earth-faults in a transformer is the *core-balance leakage protection* shown in Fig. 5.16.

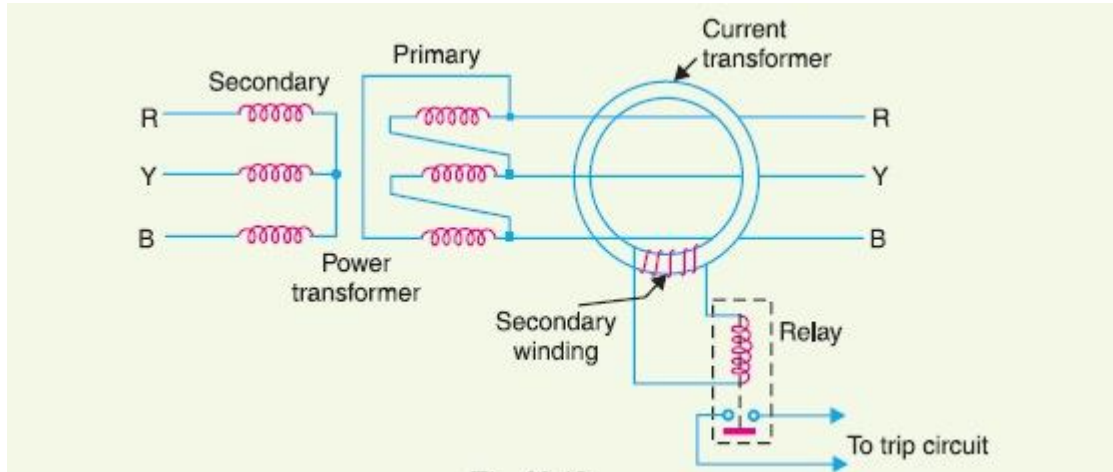

Fig 5. 16

The three leads of the primary winding of power transformer are taken through the core of a current transformer which carries a single secondary winding. The operating coil of a relay is connected to this secondary. Under normal conditions (*i.e.* no fault to earth), the vector sum of the three phase currents is zero and there is no resultant flux in the core of current transformer no matter how much the load is out of balance. Consequently, no current flows through the relay and it remains inoperative. However, on the occurrence of an earth-fault, the vector sum of three phase currents is no longer zero.

www.binils.com



The resultant current sets up flux in the core of the C.T. which induces e.m.f. in the secondary winding. This energises the relay to trip the circuit breaker and disconnect the faulty transformer from the system.

5.11 Static Relay

The static relay is the combination of both the static and the electromagnetic relay. In this relay, there is no armature and moving contacts and response is developed by the components without mechanical motion. The solid state components used are transistors, diodes, resistors, capacitor and so on. In the static relay, the measurement is performed by electronic, magnetic, optical or another component without mechanical motion.

The static components of a static relay are shown in the figure below. Here the relaying quantity, i.e., the output of a CT or PT of a transducer is rectified by the rectifier. The rectified output is given to a measuring unit constitute of comparators, level detectors, and logic circuits. The output is actuated when the dynamic input, i.e. the relaying quantity attains the threshold value.

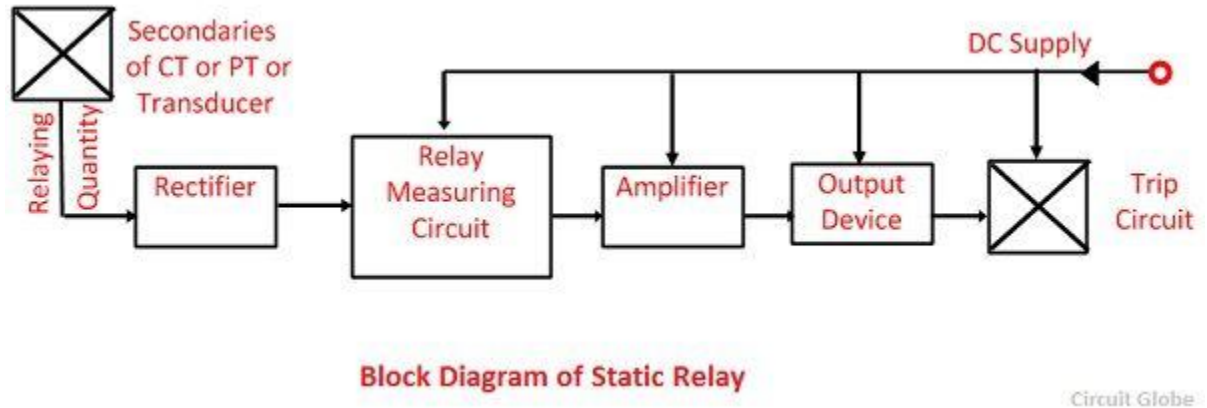

Fig 5. 17

The output of the measuring unit is fed to the output unit devices after it is amplified by the amplifiers. The output unit activates the trip coil only when the relay operates. The relaying quantity such as the voltage and current is rectified and measured. When the quantity under measurement attains certain well-defined value, the output device is energized and hence, the circuit breaker trip is triggered.

The static relay can be arranged to respond to electrical inputs. The other types of input such as heat, light, magnetic field, traveling waves, etc., can be suitably converted into equivalent analog and digital signal and then supplied to the static relay

Advantages of Static Relay

- The power consumption of the static relay is much lower and thereby decrease the burden on the instrument transformer and increased its accuracy.
- The static relay has the quick response, long life, shockproof, fewer problems of maintenance, high reliability and a high degree of accuracy.
- Quick reset action, a high reset value and the absence of overshoot can be easily achieved because of the absence of thermal storage.
- Ease of providing amplification enables greater sensitivity to be obtained.
- The risk of unwanted tripping is less with static relays.
- Static relays are quite suitable for earthquakes prone areas, ships, vehicles, airplanes, etc., This is because of high resistance to shock variation.

- A static protection control and monitoring system can perform several functions such as protection, monitoring, data acquisition measurement, memory, indication, etc.,

Limitations of Static Relay

- Some components are sensitive to electrostatic discharges. Even small charges can damage the components, and therefore precautions are necessary for the manufacturing of static relays to avoid components failures due to electrostatic discharges.
- Static relays are sensitive to voltage spikes or voltage transients. Special measures are taken to avoid such problems.
- The reliability of the system depends on a large number of small components and their electrical components.
- The static relay has low short-time overload capacity as compared to electromagnetic relays.
- Static relays are costlier, for simple and single function than their equivalent electromechanical counterparts. But for multi-functional protection, static relay proves economical.
- Highly trained personnel are required for their servicing.
- Static relays are not very robust in construction and easily affected by surrounding interference.

For integrated protection and monitoring systems programmable microprocessor controlled static relays are preferred.

5.12 Grounding: Introduction

www.binils.com

In power system, grounding or earthing means connecting frame of electrical equipment (non-current carrying part) or some electrical part of the system (e.g. neutral point in a star-connected system, one conductor of the secondary of a transformer etc.) to earth i.e. soil. This connection to earth may be through a conductor or some other circuit element (e.g. a resistor, a circuit breaker etc.) depending upon the situation. Regardless of the method of connection to earth, grounding or earthing offers two principal advantages. First, it provides protection to the power system. For example, if the neutral point of a star-connected system is grounded through a circuit breaker and phase to earth fault occurs on any one line, a large fault current will flow through the circuit breaker. The effects of the fault. Secondly, earthing of electrical equipment (e.g. domestic appliances, hand-held tools, industrial motors etc.) ensures the safety of the persons handling the equipment. For example, if insulation fails, there will be a direct contact of the live conductor with the metallic part (i.e. frame) of the equipment. Any person in contact with the metallic part of this equipment will be subjected to a dangerous electrical shock which can be fatal. In this chapter, we shall discuss the importance of grounding or earthing in the line of power system with special emphasis on neutral grounding.

Grounding or Earthing

The process of connecting the metallic frame (i.e. non-current carrying part) of electrical equipment or some electrical part of the system (e.g. neutral point in a star-connected system, one

conductor of the secondary of a transformer etc.) to earth (i.e. soil) is called **grounding** or **earthing**. It is strange but true that grounding of electrical systems is less understood aspect of power system. Nevertheless, it is a very important subject. If grounding is done systematically in the line of the power system, we can effectively prevent accidents and damage to the equipment of the power system and at the same time continuity of supply can be maintained. Grounding or earthing may be classified as : (i) Equipment grounding (ii) System grounding.

Equipment grounding deals with earthing the non-current-carrying metal parts of the electrical equipment. On the other hand, system grounding means earthing some part of the electrical system

e.g. earthing of neutral point of star-connected system in generating stations and sub-stations.

Equipment Grounding

The process of connecting non-current-carrying metal parts (i.e. metallic enclosure) of the electrical equipment to earth (i.e. soil) in such a way that in case of insulation failure, the enclosure effectively remains at earth potential is called **equipment grounding**.

We are frequently in touch with electrical equipment of all kinds, ranging from domestic appliances and hand-held tools to industrial motors. We shall illustrate the need of effective equipment grounding by considering a single-phase circuit composed of a 230 V source connected to a motor M as shown in Fig. 26.1. Note that neutral is solidly grounded at the service entrance. In the interest of easy understanding, we shall divide the discussion into three heads viz. (i) Ungrounded enclosure (ii) enclosure connected to neutral wire (iii) ground wire connected to enclosure.

- (i) **Ungrounded enclosure.** Fig. 5.18 shows the case of ungrounded metal enclosure. If a person touches the metal enclosure, nothing will happen if the equipment is functioning correctly. But if the winding insulation becomes faulty, the resistance R_e between the motor and enclosure drops to a low value (a few hundred ohms or less). A person having a body resistance R_b would complete the current path as shown in Fig. 5.18.

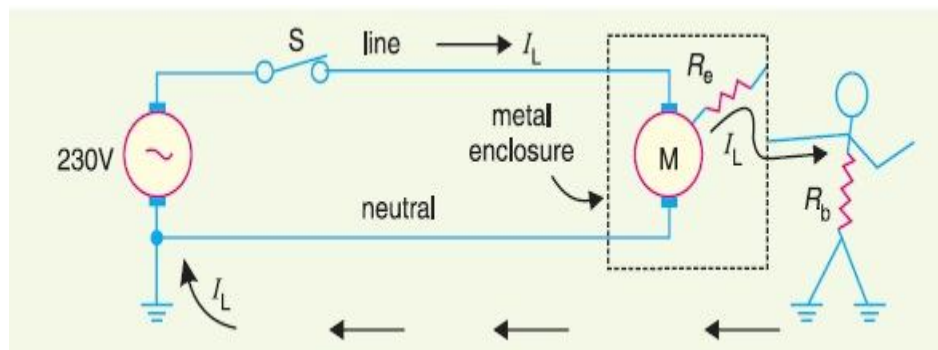

Fig 5. 18

If R_e is small (as is usually the case when insulation failure of winding occurs), the leakage current I_L through the person's body could be dangerously high. As a result, the person would get severe electric shock which may be fatal. Therefore, this system is unsafe.

(ii) Enclosure connected to neutral wire. It may appear that the above problem can be solved by connecting the enclosure to the grounded neutral wire as shown in Fig. 5.19. Now the leakage current I_L flows from the motor, through the enclosure and straight back to the neutral wire (See Fig. 5.19). Therefore, the enclosure remains at earth potential. Consequently, the operator would not experience any electric shock.

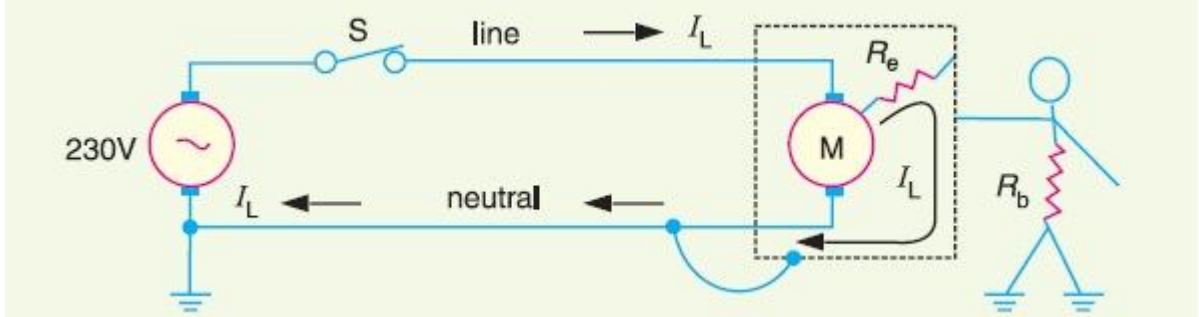

Fig 5. 19

The trouble with this method is that the neutral wire may become open either accidentally or due to a faulty installation. For example, if the switch is inadvertently in series with the neutral rather than the live wire (See Fig. 5.20), the motor can still be turned on and off. However, if someone touched the enclosure while the motor is off, he would receive a severe electric shock (See Fig. 5.20). It is because when the motor is off, the potential of the enclosure rises to that of the live conductor.

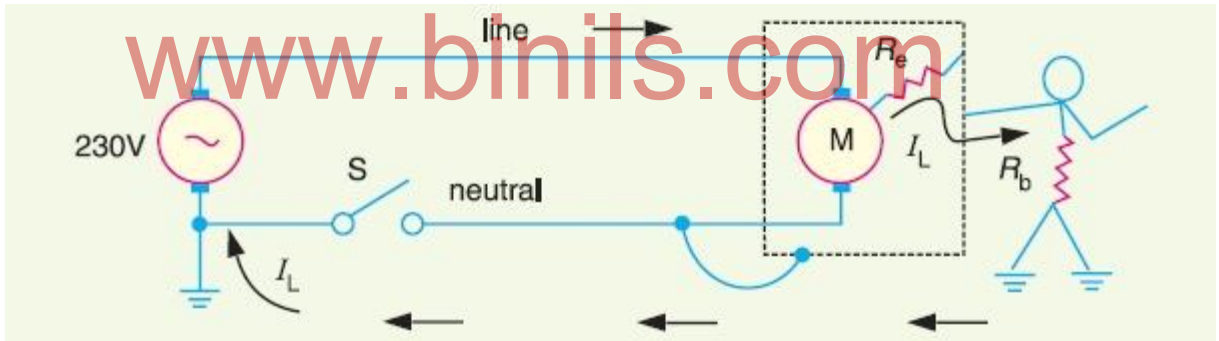

Fig 5. 20

(iii) Ground wire connected to enclosure. To get rid of this problem, we install a third wire, called ground wire, between the enclosure and the system ground as shown in Fig. 5.21. The ground wire may be bare or insulated. If it is insulated, it is coloured green.

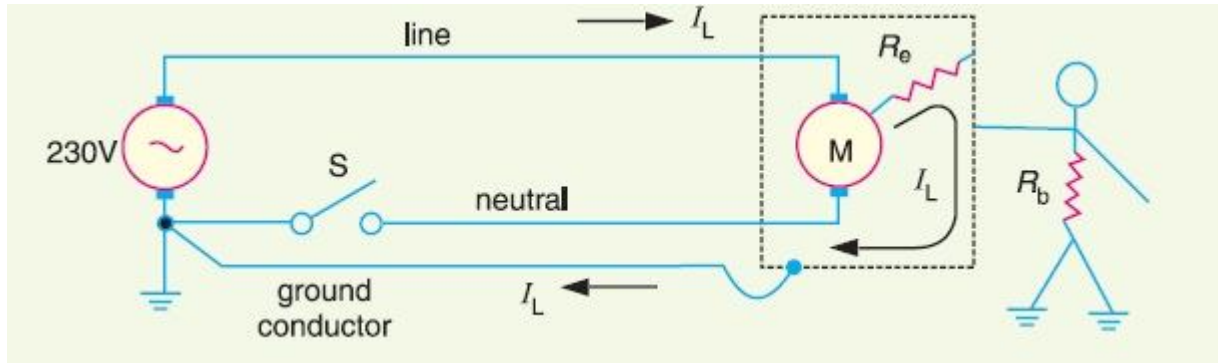

Fig 5. 21

Electrical outlets have three contacts — one for live wire, one for neutral wire and one for ground wire

System Grounding

The process of connecting some electrical part of the power system (e.g. neutral point of a star connected system, one conductor of the secondary of a transformer etc.) to earth (i.e. soil) is called **system grounding**.

The system grounding has assumed considerable importance in the fast expanding power system. By adopting proper schemes of system grounding, we can achieve many advantages including protection, reliability and safety to the power system network. But before discussing the various aspects of neutral grounding, it is desirable to give two examples to appreciate the need of system grounding.

(i) Fig. 5.22 (i) shows the primary winding of a distribution transformer connected between the line and neutral of a 11 kV line. If the secondary conductors are ungrounded, it would appear that a person could touch either secondary conductor without harm because there is no ground return. However, this is not true. Referring to Fig. 5.22, there is capacitance C_1 between primary and secondary and capacitance C_2 between secondary and ground. This capacitance coupling can produce a high voltage between the secondary lines and the ground.

Depending upon the relative magnitudes of C_1 and C_2 , it may be as high as 20% to 40% of the primary voltage. If a person touches either one of the secondary wires, the resulting capacitive current I_C flowing through the body could be dangerous even in case of small transformers [See Fig. 5.22]. For example, if I_C is only 20 mA, the person may get a fatal electric shock.

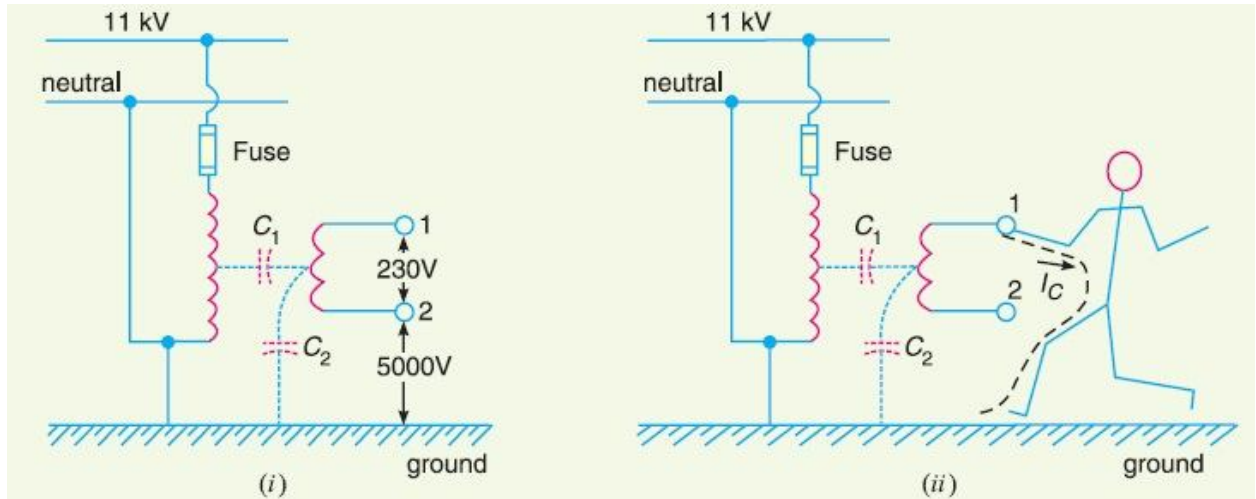

Fig 5. 22

If one of the secondary conductors is grounded, the capacitive coupling almost reduces to zero and so is the capacitive current I_C . As a result, the person will experience no electric shock. This explains the importance of system grounding.

- (ii) Let us now turn to a more serious situation. Fig. 5.22 (i) shows the primary winding of a distribution transformer connected between the line and neutral of a 11 kV line. The secondary conductors are ungrounded. Suppose that the high voltage line (11 kV in this case) touches the 230 V conductors as shown in Fig. 5.22 (i). This could be caused by an internal fault in the transformer or by a branch or tree falling across the 11 kV and 230 V lines. Under these circumstances, a very high voltage is imposed between the secondary conductors and ground. This would immediately puncture the 230 V insulation, causing a massive flashover. This flashover could occur anywhere on the secondary network, possibly inside a home or factory. Therefore, ungrounded secondary in this case is a potential fire hazard and may produce grave accidents under abnormal conditions.

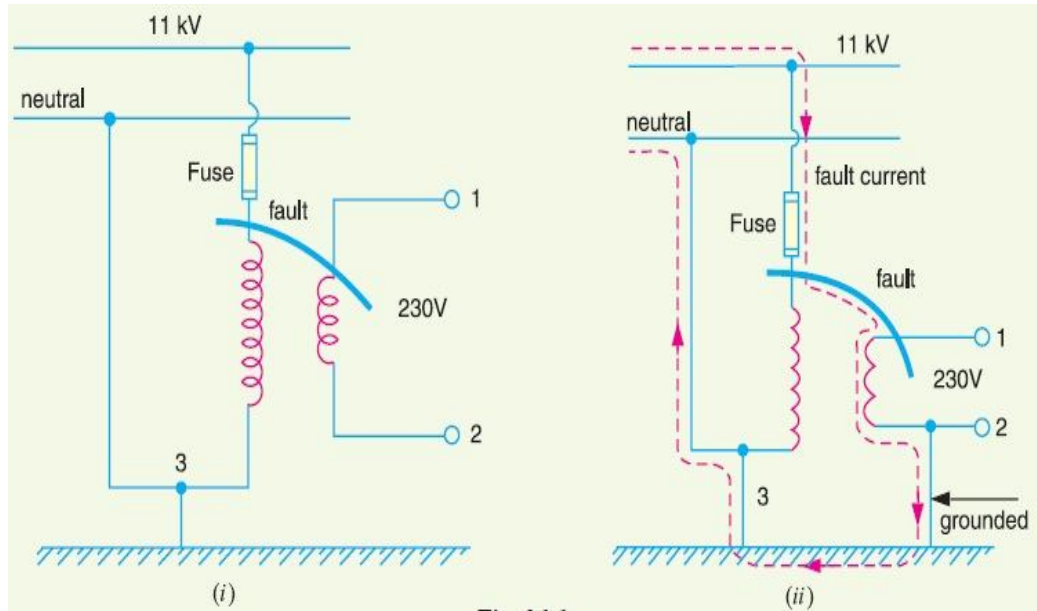

Fig 5. 23

If one of the secondary lines is grounded as shown in Fig.5.23, the accidental contact between a 11 kV conductor and a 230 V conductor produces a dead short. The short-circuit current (i.e. fault current) follows the dotted path shown in Fig. 5.23. This large current will blow the fuse on the 11 kV side, thus disconnecting the transformer and secondary distribution system from the 11 kV line. This explains the importance of system grounding in the line of the power system.

5.13 Ungrounded Neutral System

In an ungrounded neutral system, the neutral is not connected to the ground i.e. the neutral is isolated from the ground. Therefore, this system is also called isolated neutral system or free neutral system. Fig. 5.24 shows ungrounded neutral system. The line conductors have capacitances between one another and to ground. The former are delta-connected while the latter are star-connected. The delta-connected capacitances have little effect on the grounding characteristics of the system (i.e. these capacitances do not effect the earth circuit) and, therefore, can be neglected. The circuit then reduces to the one shown in Fig. 5.24

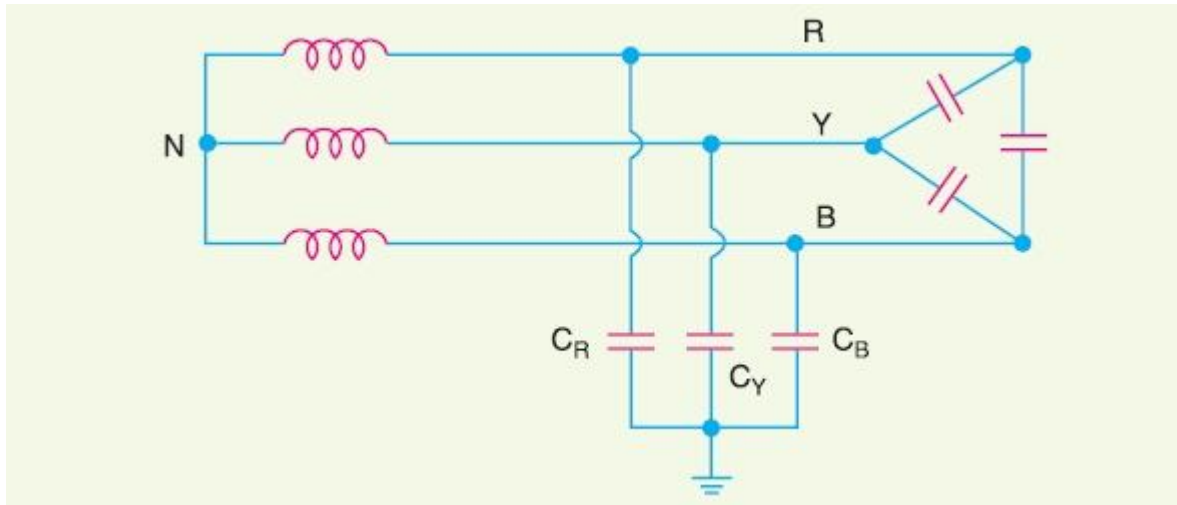

Fig 5. 24

5.14 Neutral Grounding

The process of connecting neutral point of 3-phase system to earth (i.e. soil) either directly or through some circuit element (e.g. resistance, reactance etc.) is called **neutral grounding**.

Neutral grounding provides protection to personal and equipment. It is because during earth fault, the current path is completed through the earthed neutral and the protective devices (e.g. a fuse etc.) operate to isolate the faulty conductor from the rest of the system. This point is illustrated in Fig. 5.25.

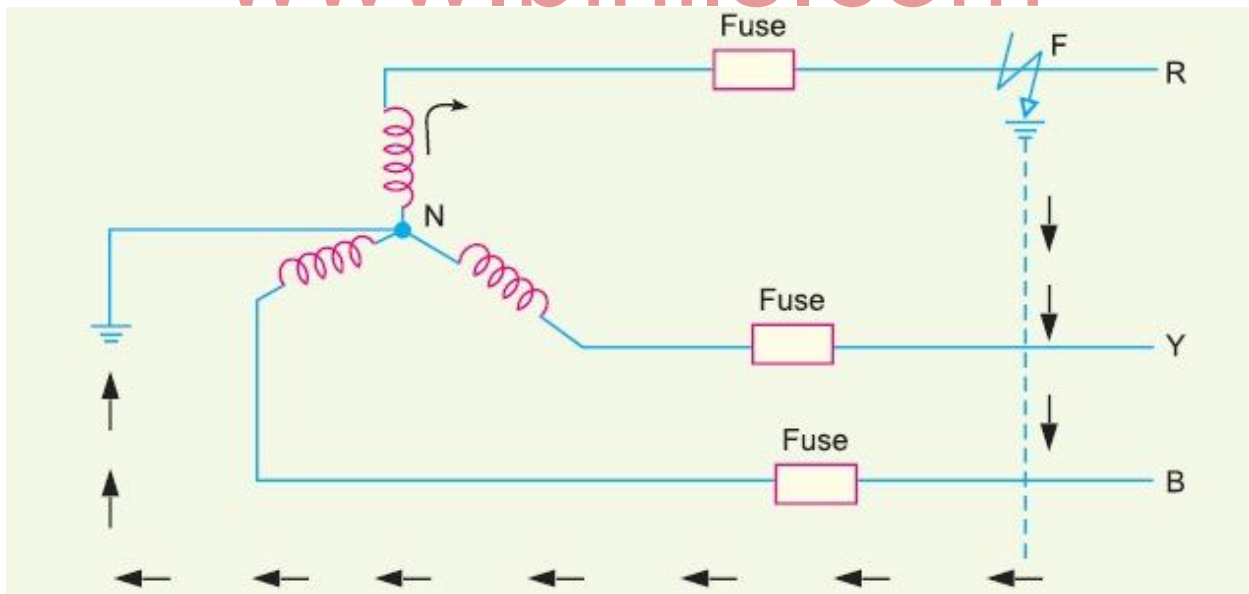

Fig 5. 25

Fig. 5.25 shows a 3-phase, star-connected system with neutral earthed (i.e. neutral point is connected to soil). Suppose a single line to ground fault occurs in line R at point F. This will cause the current to flow

through ground path as shown in Fig. 5.25. Note that current flows from R-phase to earth, then to neutral point N and back to R-phase. Since the impedance of the current path is low, a large current flows through this path. This large current will blow the fuse in R-phase and isolate the faulty line R. This will protect the system from the harmful effects (e.g. damage to equipment, electric shock to personnel etc.) of the fault. One important feature of grounded neutral is that the potential difference between the live conductor and ground will not exceed the phase voltage of the system i.e. it will remain nearly constant.

Advantages of Neutral Grounding

The following are the advantages of neutral grounding :

- (i) Voltages of the healthy phases do not exceed line to ground voltages i.e. they remain nearly constant.
- (ii) The high voltages due to arcing grounds are eliminated.
- (iii) The protective relays can be used to provide protection against earth faults. In case earth fault occurs on any line, the protective relay will operate to isolate the faulty line.
- (iv) The overvoltage's due to lightning are discharged to earth.
- (v) It provides greater safety to personnel and equipment.
- (vi) It provides improved service reliability.
- (vii) Operating and maintenance expenditures are reduced.

5.15 Methods of Neutral Grounding

The methods commonly used for grounding the neutral point of a 3-phase system are :

- (i) Solid or effective grounding
- (ii) Resistance grounding
- (iii) Reactance grounding
- (iv) Peterson-coil grounding

The choice of the method of grounding depends upon many factors including the size of the system, system voltage and the scheme of protection to be used.

5.15.1 Solid Grounding

When the neutral point of a 3-phase system (e.g. 3- phase generator, 3-phase transformer etc.) is directly connected to earth (i.e. soil) through a wire of negligible resistance and reactance, it is called **solid grounding** or **effective grounding**.

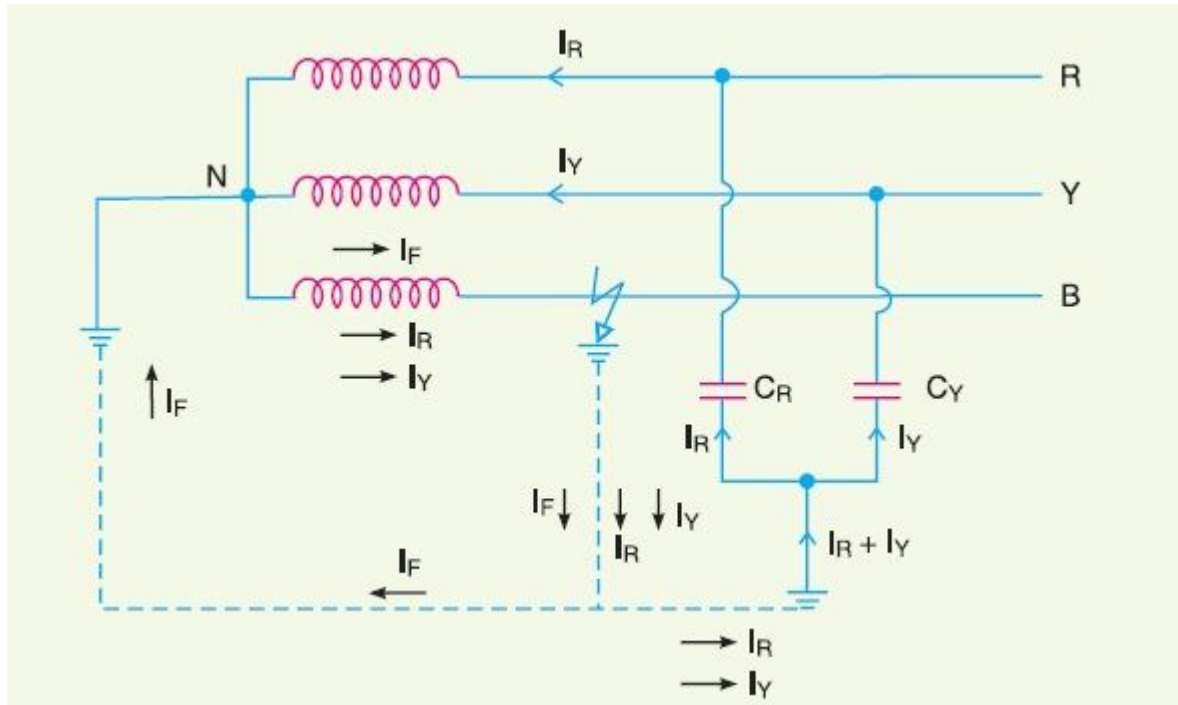

Fig 5. 26

Fig. 5.26. shows the solid grounding of the neutral point. Since the neutral point is directly connected to earth through a wire, the neutral point is held at earth potential under all conditions. Therefore, under fault conditions, the voltage of any conductor to earth will not exceed the normal phase voltage of the system.

Advantages. The solid grounding of neutral point has the following advantages :

- (i) The neutral is effectively held at earth potential.
- (ii) When earth fault occurs on any phase, the resultant capacitive current I_C is in phase opposition to the fault current I_F . The two currents completely cancel each other. Therefore, no arcing ground or over-voltage conditions can occur. Consider a line to ground fault in line B as shown in Fig. 5.26. The capacitive currents flowing in the healthy phases R and Y are I_R and I_Y respectively. The resultant capacitive current I_C is the phasor sum of I_R and I_Y . In addition to these capacitive currents, the power source also supplies the fault current I_F . This fault current will go from fault point to earth, then to neutral point N and back to the fault point through the faulty phase. The path of I_C is capacitive and that of I_F is inductive. The two currents are in phase opposition and completely cancel each other. Therefore, no arcing ground phenomenon or over-voltage conditions can occur.
- (iii) When there is an earth fault on any phase of the system, the phase to earth voltage of the faulty phase becomes zero. However, the phase to earth voltages of the remaining two healthy phases remain at normal phase voltage because the potential of the neutral is fixed at earth potential. This permits to insulate the equipment for phase voltage. Therefore, there is a saving in the cost of equipment.

(iv) It becomes easier to protect the system from earth faults which frequently occur on the system. When there is an earth fault on any phase of the system, large fault current flows between the fault point and the grounded neutral. This permits the easy operation of earth fault relay.

Disadvantages.

The following are the disadvantages of solid grounding :

- (i) Since most of the faults on an overhead system are phase to earth faults, the system has to bear a large number of severe shocks. This causes the system to become unstable.
- (ii) The solid grounding results in heavy earth fault currents. Since the fault has to be cleared by the circuit breakers, the heavy earth fault currents may cause the burning of circuit breaker contacts.
- (iii) The increased earth fault current results in greater interference in the neighbouring communication lines.

Applications.

Solid grounding is usually employed where the circuit impedance is sufficiently high so as to keep the earth fault current within safe limits. This system of grounding is used for voltages upto 33 kV with total power capacity not exceeding 5000 kVA.

5.15.2 Resistance Grounding

In order to limit the magnitude of earth fault current, it is a common practice to connect the neutral point of a 3-phase system to earth through a resistor. This is called *resistance grounding*.

*When the neutral point of a 3-phase system (e.g. 3-phase generator, 3-phase transformer etc.) is connected to earth (i.e. soil) through a resistor, it is called **resistance grounding**.*

Fig. 5.27 shows the grounding of neutral point through a resistor R . The value of R should neither be very low nor very high. If the value of earthing resistance R is very low, the earth fault current will be large and the system becomes similar to the solid grounding system. On the other hand, if the earthing resistance R is very high, the system conditions become similar to ungrounded

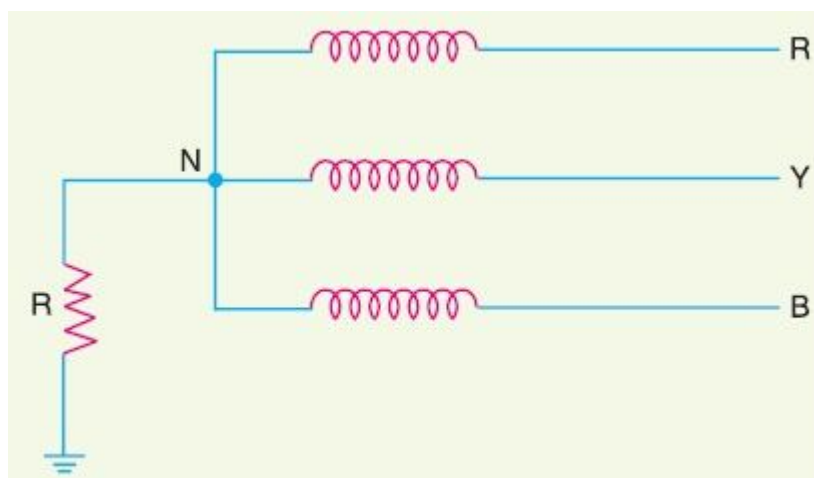

Fig 5. 27

neutral system. The value of R is so chosen such that the earth fault current is limited to safe value but still sufficient to permit the operation of earth fault protection system. In practice, that value of R is selected that limits the earth fault current to 2 times the normal full load current of the earthed generator or transformer.

Advantages.

The following are the advantages of resistance earthing:

- (i) By adjusting the value of R , the arcing grounds can be minimised. Suppose earth fault occurs in phase B as shown in Fig. 5.28. The capacitive currents I_R and I_Y flow in the healthy phases R and Y respectively. The fault current I_F lags behind the phase voltage of the faulted phase by a certain angle depending upon the earthing resistance R and the reactance of the system upto the point of fault. The fault current I_F can be resolved into two components *viz.*

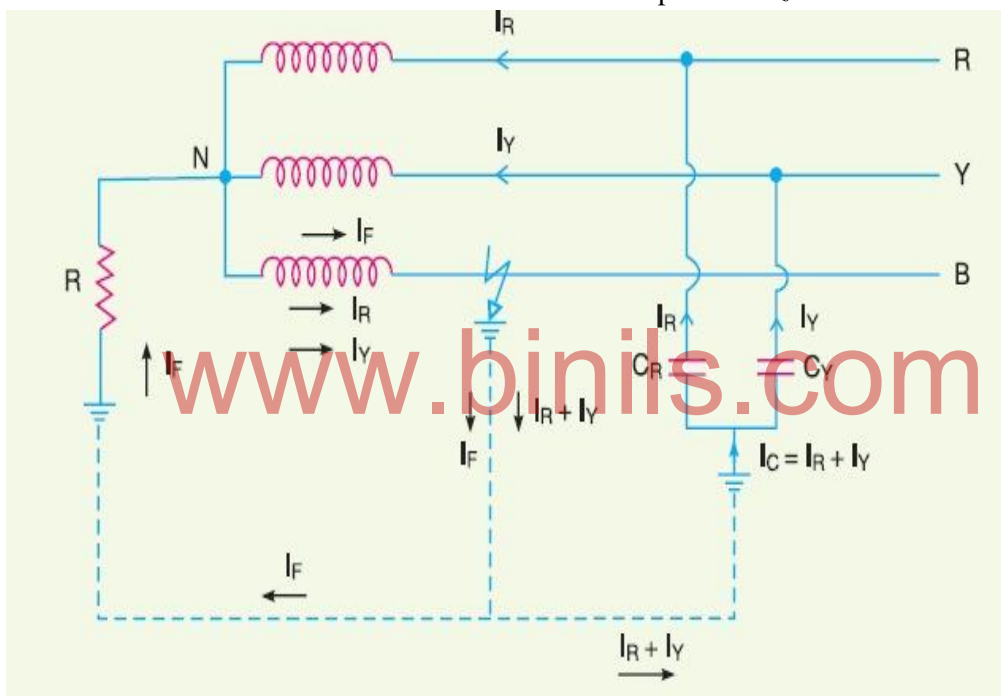

Fig 5. 28

- (a) I_{F1} in phase with the faulty phase voltage.
- (b) I_{F2} lagging behind the faulty phase voltage by 90° .

The lagging component I_{F2} is in phase opposition to the total capacitive current I_C . If the value of earthing resistance R is so adjusted that $I_{F2} = I_C$, the arcing ground is completely eliminated and the operation of the system becomes that of solidly grounded system. However, if R is so adjusted that $I_{F2} < I_C$, the operation of the system becomes that of ungrounded neutral system.

- (ii) The earth fault current is small due to the presence of earthing resistance. Therefore, interference with communication circuits is reduced.
- (iii) It improves the stability of the system.

Disadvantages.

The following are the disadvantages of resistance grounding :

- (i) Since the system neutral is displaced during earth faults, the equipment has to be insulated for higher voltages.
- (ii) This system is costlier than the solidly grounded system.
- (iii) A large amount of energy is produced in the earthing resistance during earth faults. Sometimes it becomes difficult to dissipate this energy to atmosphere.

Applications.

It is used on a system operating at voltages between 2.2 kV and 33 kV with power source capacity more than 5000 kVA.

5.15.3 Reactance Grounding

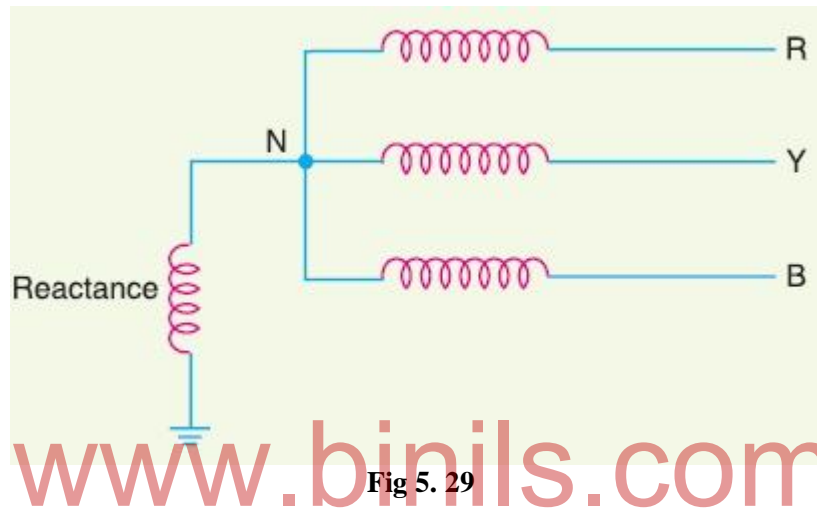

Fig 5. 29

In this system, a reactance is inserted between the neutral and ground as shown in Fig. 5.29. The purpose of reactance is to limit the earth fault current. By changing the earthing reactance, the earth fault current can be changed to obtain the conditions similar to that of solid grounding. This method is not used these days because of the following disadvantages:

- (i) In this system, the fault current required to operate the protective device is higher than that of resistance grounding for the same fault conditions.
- (ii) High transient voltages appear under fault conditions.

5.15.4 Resonant Grounding

This system is also referred as arc suppression coil grounding. In the previous earthing methods that we have discussed the earth fault on any one of the phases caused total shut down of the system. So continuity of supply can be maintained. This is not the case with ungrounded system where fault on one phase will not cause other phases to supply power. This method of grounding has this advantage of isolated neutral system along with reduced possibility of arcing grounds and numerous other advantages.

It consists of a coil called Peterson coil or Ground fault neutralizer or arc suppression coil whose function is to make arcing earth faults self extinguishing and in the case of sustained faults to reduce the earth current to low value so that system can supply power with one line earthed.

This system works on the principle that when inductance and capacitance are connected in parallel, resonance takes place between them and because of the characteristics of resonance, the fault current is reduced or can be neutralized.

The system with fault on phase B is shown in the Fig. 5.30(a). The corresponding phasor diagram is shown in the Fig. 5.30(b).

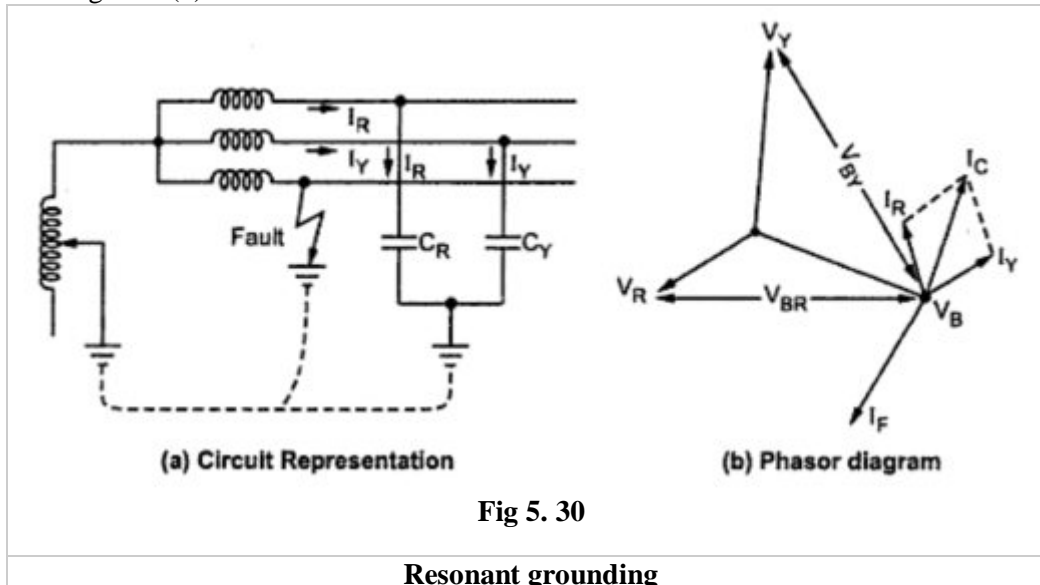

An arc suppression coil is an iron-cored reactor similar to oil immersed transformer connected between neutral of system and earth. This coil is provided with number of tapings so that it can be tuned with the capacitance which may vary due to varying operational conditions.

As the system operation is similar to isolated neutral system, the phase to earth voltage of healthy phase is times the normal phase voltage and the resultant capacitive current is $\sqrt{3}$ times the normal charging current of one phase. The resultant capacitive current will lead by with faulty phase voltage while the fault current lags by with faulty phase voltage.

Now we have, $I_F = I_C$ at resonance

$$I_F = V_{ph}/X_L \quad ; \quad I_C = 3V_{ph}/X_C$$

The rating of the coil is continuous and equal to the maximum earth fault current. If a double phase to ground fault or another ground fault occurs, the current flowing through the coil is more. This can be prohibited with closing of a circuit breaker after certain time lag. The earth fault current flows through the parallel circuit by passing the arc suppression coil. Here the circuit breaker is normally open and closes after the closure of relay tripping circuit by passing arc suppression coil.

This method of neutral grounding is used in medium voltage overhead transmission line which are connected to system generators through intermediate power transformers. This is because the higher insulation requirement on the apparatus associated with arc suppression coil grounding system is easily incorporated in power transformers than in generators. Also the overhead lines are usually subjected to earth faults due to lightning. Hence protection is required.

5.1.5.5 Grounding Transformer

If the *earthing transformer* on the Delta Side is outside the Zone of protection the Earth Fault(E/F) in the delta system outside Current Transformer (CT) locations would produce current distributions as shown which circulate within the differential CT secondary's and is kept out of operating coils. Zigzag or interconnected star grounding transformer has normal magnetizing impedance of high

value but for E/F, currents flow in windings of the same - core in such a manner that the ampere turn cancel and hence offer lower impedance. In cases where the neutral point of three phase system is not accessible like the system connected to the delta connected side of a electrical power transformer, an artificial neutral point may be created with help of a zigzag connected earthing transformer.

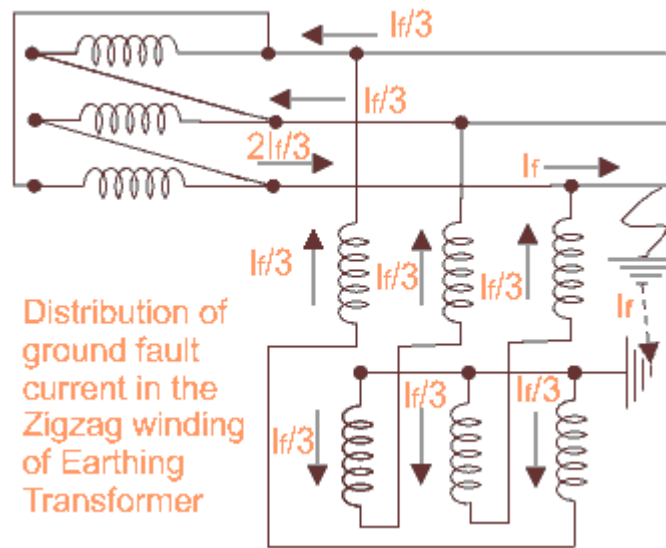

www.binils.com
Fig 5. 31

This is a core type transformer with three limbs. Every phase winding in zigzag connection is divided into two equal halves. One half of which is wound on one limb and other half is wound on another limb of the core of transformer.

1st half of Red phase winding is wound on the 1st limb of the core and 2nd half of same Red phase is wound on 3rd limb. 1st half of Yellow phase winding is wound on the 2nd limb of the core and 2nd half of same Yellow phase is wound on 1st limb. 1st half of Blue phase winding is wound on the 3rd limb of the core and 2nd half of same Blue phase is wound on 2nd limb. End point of all three winding ultimately connected together and forms a common neutral point. Now if any fault occurs at any of the phases in delta connected system, the zero sequence fault current has close path of circulating through earth as shown in the figure. In normal condition of the system, the voltage across the winding of the earthing transformer is $1/\sqrt{3}$ times of rated per phase voltage of the system. But when single line to ground fault occurs on any phase of the system, as shown in the figure, zero sequence component of the earth fault current flows in the earth and returns to the electrical power system by way of earth star point of the **earthing transformer**. It gets divided equally in all the three phases. Hence, as shown in the figure, the currents in the two different halves of two windings in the same limb of the core flow in opposite directions. And therefore the magnetic flux set up by these two currents will oppose and neutralize each other. As there is no increase in flux due to fault current, there is no change of $d\phi/dt$ means no choking effect occurs to impede the flow of fault current. So it can be concluded like that, the

zigzag type earthing or **grounding transformer** maintains the rated supply voltage at normal current as well as when a solid single line to ground fault current flows through it.



Fig 5.32

The rated voltage of an earthing or grounding transformer is the line to line voltage on which it is intended to be used. Current rating of this transformer is the maximum neutral current in Amperes that the transformer is designed to carry in fault condition for a specific time. Generally the time interval, for which transformer designed to carry the maximum fault current through it safely, is taken as 30 second.

Advantages.

The following are the advantages of voltage transformer earthing :

- (i) The transient overvoltages on the system due to switching and arcing grounds are reduced. It is because voltage transformer provides high reactance to the earth path.
- (ii) This type of earthing has all the advantages of ungrounded neutral system.
- (iii) Arcing grounds are eliminated.

Disadvantages.

The following are the disadvantages of voltage transformer earthing :

- (i) When earth fault occurs on any phase, the line voltage appears across line to earth capacitances. The system insulation will be overstressed.
- (ii) The earthed neutral acts as a reflection point for the travelling waves through the machine winding. This may result in high voltage build up.

Applications.

The use of this system of neutral earthing is normally confined to generator equipments which are directly connected to step-up power transformers.

REVIEW QUESTIONS

2 MARK AND 3 MARKS

1. What are the functions of protective relays?
2. Give the consequences of short circuit.
3. Define protected zone.
4. What are unit system and non unit system?
5. What is primary protection?
6. What is back up protection?
7. Name the different kinds of over current relays.
8. Define energizing quantity.
9. Define operating time of a relay.
10. Define resetting time of a relay.
11. What are over and under current relays?
12. Mention any two applications of differential relay.
13. What is biased differential bus zone reduction?
14. State the types of faults in Power system.
15. How is 'arcing ground' avoided?
16. Define the following terms as related to protective relaying: (a) pick-up current, (b) reset value
17. What are the requirements of line protection?
18. What is the need for power system earthing?

10 MARKS

1. What are the earth leakage relays? Discuss their area of application.
3. Describe the operating principle, constructional features and area of applications of Reverse power or directional relay.
4. Describe the construction and principle of operation of an induction type directional over Current relay.
5. Explain the working principle of distance relays.
6. Write a detailed note on differential relays.
7. Explain any two methods of neutral grounding.
8. Explain the working of Inverse Definite Minimum Timelag (I.D.M.T.) Relay.