



DOTe TAMILNADU

Government of Tamil Nadu

ENVIRONMENTAL ENGINEERING & POLLUTION CONTROL

DIPLOMA COURSE IN CIVIL ENGINEERING

FIFTH SEMESTER / THIRD YEAR

A Publication under
Government of Tamil Nadu
Distribution of Free Text Book Programme
(NOT FOR SALE)

Untouchability is a sin

Untouchability is a crime

Untouchability is a inhuman

DIRECTORATE OF TECHNICAL EDUCATION

GOVERNMENT OF TAMIL NADU

Government of Tamil Nadu

First Edition – 2018

CHAIR PERSON

Dr. R.PALNISWAMY I.A.S.,

Commissioner of Technical Education (FAC) / Chief Implementation Officer/

Directorate of Technical Education Guindy, Chennai- 600025.

CONVENER:

Er.N.MURALI KRISHNIAH,,
PRINCIPAL / WPT & PRINCIPAL (Addl. Charge)
IPT, Tharamani
Chennai - 600 113.

AUTHORS:

Dr. V.PON.PANNEERSELVAM,,
HOD (UG) / CIVIL
Pattukottai Polytechnic College,
Pattukottai, Tamil Nadu – 614601.

Er.S.SANTHI,,
LECTURER (SR.GR)/ CIVIL,
A.M.K. Technological Polytechnic College,
Chennai Bangalore High Road,
Sembarambakkam, Chennai – 600123

Er. A. BALASUBRAMANIYAN,,
LECTURER/CIVIL
Government Polytechnic College
Perambalur - 621104

REVIEWER :

Dr V.KARTHIKEYAN
PRINCIPAL
Thiagarajar polytechnic college
Salem

This book has been prepared by the Directorate of Technical Education

This book has been printed on 60 G.S.M Paper

Through the Tamil Nadu Text book and Educational Services Corporation



PREFACE

We are in much happiest occasion to present ENVIRONMENTAL ENGINEERING and POLLUTION CONTROL book for Diploma in Civil Engineering under Directorate of Technical Education, Tamil Nadu. An attempt has been made in this text learning material to meet the requirements and standards of curriculum of Environmental Engineering and Pollution Control of fifth semester civil engineering prescribed by DOTE.

It is important to every human being to have knowledge of environment, its impact on lives and control of pollution in the unconditional developing modern natures. To help and solve such conflicts, this book deals about the basics of water supply engineering in first and second units, third and fourth units are dealt with usual sanitary engineering practices adopted and fifth unit explains the environmental pollution and its impact assessments.

It is hoped that with the basic principles of environmental engineering and pollution control lucidly exposed in this text, the readers and learners will be able to understand and pursue further in their studies. This book is written in simple and easily understandable manner. Tabular columns, illustrative figures and worked examples are suitably accommodated. At the end of each unit typical two, three and ten marks questions possible to board examination are given.

The convener, authors and reviewer are very much grateful to the Commissioner of Technical Education Chennai for his deep involvement and encouragement in preparing this syllabus based learning material. Thanks are due to officials of DOTE, Chennai for their timely help whenever needed. Further suggestions and fair criticisms are welcome for fine tuning in future

CONVENER, AUTHORS and REVIEWER

31052 ENVIRONMENTAL ENGINEERING AND POLLUTION CONTROL

DETAILED SYLLABUS

UNIT – I

PART I - WATER SUPPLY ENGINEERING

1.1 QUANTITY OF WATER

13 Hours

Water supply - need for protected water supply - objectives of public water supply system – demand -types of demand - per capita demand - prediction of population - problems in arithmetical increase method, geometrical increase method, incremental increase method - sources of water - surface and subsurface sources.

1.2 INTAKES AND CONVEYANCE

Intakes - types of intakes-description of intakes-infiltration galleries and infiltration wells in river beds - necessity of pumps - types of pumps - pipes for conveyance of water - cast iron, steel, G.I., cement concrete, R.C.C., Hume and PVC pipes-pipe joints -laying and testing of pipe lines - pipe corrosion - corrosion control.

1.3 QUALITY OF WATER

Impurities in water - Testing of water - Collection of water sample - Physical, Chemical, and Bacteriological tests - Standards of drinking water - water borne diseases and their causes.

UNIT – II

2.1 TREATMENT OF WATER

13 Hours

Objectives of water treatment - flow diagram of treatment plants – sedimentation – purpose - types of sedimentation - coagulation - coagulants and their choice - types of sedimentation tanks – filtration - theory of filtration - types and description of filters - disinfection of water – methods - water softening –miscellaneous water treatment(names only) - mineral water – requirements - R.O process.

2.2 DISTRIBUTION SYSTEM

Distribution system - methods of distribution – gravity system, pumping system, combined system - systems of water supply - continuous and intermittent supply of water - layouts of distribution - dead end , grid iron, radial and circular systems - service reservoirs - types

UNIT – III

PART II - SANITARY ENGINEERING

13 Hours

3.1 COLLECTION AND CONVEYANCE OF SEWAGE

Sanitation – purpose – terms - systems of sanitation - quantity of sewage - variation in rate of flow of sewage - estimation of storm water – problems - minimum size of sewer - shapes of sewer (names only) -materials used for sewer- joints in sewer line - laying and testing of sewer lines - ventilation of sewers -cleaning of sewers.

3.2 SEWER APPURTENANCES

Sewer appurtenances – manhole - lamp hole - catch basin - street inlet - grease and oil trap - flushing tanks – drainage arrangements in buildings - sanitary fittings - sewage pumps –necessity - types of sewage pumps (names only).

UNIT – IV

4.1 TREATMENT AND DISPOSAL OF SEWAGE

13 Hours

Objectives of sewage treatment - flow diagram of sewage treatment plants - treatment of sewage - primary and secondary treatments - screens - skimming tanks - grit chambers - sedimentation tanks – filters - types and description of filters - activated sludge process - septic tanks for isolated buildings - construction and working of septic tanks - disposal of septic tank effluent – soak pits, dispersion trenches - oxidation ponds – sludge – types - methods of sludge disposal.

4.2 SOLID WASTE MANAGEMENT

13 Hours

Solid waste – classification - collection and conveyance of solid waste - disposal of solid waste – necessity - reduction and reuse of solid wastes - methods of solid waste disposal - incineration, dumping, sanitary landfill , composting - energy from waste

UNIT – V

PART III - POLLUTION CONTROL

5.1 ENVIRONMENTAL POLLUTION

13 Hours

Environment – definition - water pollution - sources of water pollution - effects of water pollution - control of water pollution - soil pollution - sources of soil pollution - effects of soil pollution - control of soil pollution - noise pollution - sources of noise pollution - effects of noise pollution - control of noise pollution - air pollution - sources of air pollution - effects of air pollution on human beings, plants, animals, materials - air pollution control equipment - control devices for particulate contaminants – environmental degradation - ozone layer depletion - green house effect - acid rain.

5.2 ENVIRONMENTAL IMPACT ASSESSMENT

Environmental impact assessment (EIA) - methodology of EIA - organising the job - performing the assessment - preparation of environmental impact statement (EIS) - review Of EIS
environmental risk assessment - limitation of EIA.

Revision and Test

10 Hours

www.binils.com

CONTENTS

S.NO	UNIT	TITLE	PAGE
1	1	PART I - WATER SUPPLY ENGINEERING	
		1.1 QUANTITY OF WATER	8-19
		1.2 INTAKES AND CONVEYANCE	20-32
		1.3 QUALITY OF WATER	33-40
		Review Questions I unit	41-43
2	II	2.1 TREATMENT OF WATER	44-63
		2.2 DISTRIBUTION SYSTEM	64-73
		Review Questions II unit	74-76
3	III	PART II - SANITARY ENGINEERING	
		3.1 COLLECTION AND CONVEYANCE OF SEWAGE	77-95
		3.2 SEWER APPURTENANCES	96-109
		Review Questions III unit	110-112
4	IV	4.1 TREATMENT AND DISPOSAL OF SEWAGE	113-141
		4.2 SOLID WASTE MANAGEMENT	142-151
		Review Questions IV unit	151-153
5	V	PART III - POLLUTION CONTROL	
		5.1 ENVIRONMENTAL POLLUTION	154-188
		5.2 ENVIRONMENTAL IMPACT ASSESSMENT	189-196
		Review Questions V unit	197-198

PART I
WATER SUPPLY ENGINEERING

UNIT – I

(1.1: Water supply - need for protected water supply - objectives of public water supply system – demand -types of demand - per capita demand - prediction of population - problems in arithmetical increase method, geometrical increase method, incremental increase method - sources of water - surface and subsurface sources)

1.1 – QUANTITY OF WATER

1.1.1 Introduction

The important requirement of any life including human is water. It is nature's gift to lives. It is available in various forms such as rivers, lakes, streams, ponds etc. The development of any city is based on the source of water supply.

Universally every living soul requires water for its survival. It is essential for life, health and sanitation. It is the principal raw material for food production and on the farms. Human can live without food for about 2 months, but cannot survive for two or three days without water. It also plays vital role in the production of essential commodities, generation of electric power, transportation, recreation etc..... With our growing population, the demand for water is increasing day by day and hence every country ensures the availability of pollution free water resources.

1.1.2 Need of Protect Water Supplies:

The water when exposed to atmosphere definitely contains several contaminants which are dangerous to any living organisms. Consumption of polluted water may cause serious diseases to the health of living beings. Hence it is very much needed to protect water supplies.

1.1.3 Objectives of Water Supply:

The following are the objectives of water supply system

1. Through the supply of whole some water, the public health will be improved
2. Sanitation of surroundings will be improved
3. Fire safety will be ensured
4. The living standards of people will be improved by industrialization
5. Health and Wealth will be improved at the maximum limit.

1.1.4 Demand:

When an engineer has to design a water supply scheme for a community, he has to ascertain the required quantity of water and its availability. The quantity of water required to meet out the various needs of communities is called demand of water.

The following are the types of demand.

1. Domestic demand
2. Civic or Public demand
3. Industrial demand
4. Waste and loss

1.1.4.1 Domestic Demand

- | | | |
|--------------------------------|---|--------|
| 1. Drinking | - | 2 lit |
| 2. Cooking | - | 5 lit |
| 3. Bathing | - | 40 lit |
| 4. Washing hands face etc | - | 10 lit |
| 5. House hold sanitary purpose | - | 50 lit |
| 6. Gardening | - | 15 lit |
| 7. Domestic animals & vehicles | - | 13 lit |

Thus the quantity of water required for domestic purposes can be calculated as above. Normally it varies from 100 lit – 135 lit per head per day.

1.1.4.2 Civic or Public:

The quantity of water for these purposes can be divided into road washing, sanitation purposes ornamental purposes and fire demands. Normally this category is taken as 10 lit per head per day.

1.1.4.3 Industrial purposes:

The quantity of water required for this purpose is taken into account as factories, power stations, railways etc. and it will be taken as 50 lit per head per day.

1.1.4.4 Waste and Losses:

The quantity of water for these categories is taken into account as careless use of water, leakages, unauthorized usage of water etc., Normally it is assumed as 75 lit per head per day.

1.1.5 Per capita demand or Rate of demand :

The quantity of water required by a person per day for his personal use is termed as per capita demand. For average Indian towns per capita consumption of water per day for domestic, civic or public, Industries and waste and loss are worked out between 150 and 300 litres.

1.1.5.1 Fire demand:

The quantity of water required to put off sudden occurrence of fire is termed as fire demand. Fire hydrants fitted in mains is used to take the required quantity of water to put off fire. The hydrants are located in the mains at distance not more than 150m.

1.1.5.2 Factors affecting per capita demand:

There are various factors which influence the rate of demand of water. Following are some of the factors which affect the rate of demand.

1. Climatic condition
2. Cost of water
3. Distribution pressure
4. Habits of population
5. Industries
6. Metering
7. Quality of water
8. Sewerage
9. Size of city
10. System of water supply

1. Climatic condition:

The climate of nature will affect the per capita demand. The requirement of water in summer is more than that in winter. Hotter places require more water than cooler places.

2. Cost of Water:

If the water supplied to the consumers is charged, it will affect the per capita demand. The higher is the cost, the lower will be the consumption. If it is free supply, the consumption will be more.

3. Distribution pressure:

More pressure leads to more consumption and less pressure leads to low consumption.

4. Habits of population:

The living standards of people influence the rate of consumption. Rich peoples may consume more quantity of water, middle class peoples use an average quantity and poor people consume less quantity of water.

5. Industries:

The presence and absence of industries in a town may affect the rate of demand.

6. Metering:

The quantity of water supplied is recorded by a meter and the consumption will be charged accordingly. The installation of meter may affect the rate of demand.

7. Quality of water:

The good quality of water may increase the rate of consumption. Poor quality of water leads to less consumption.

8. Sewerage:

The existence of good sewerage system will increase the consumption of water and thus affect the rate of demand.

9. Size of city:

Smaller the town, the lower is the rate of consumption. But the presence of water consuming industries in small towns results more consumption and thus affects the rate of demand.

10. System of water supply:

The continuous supply of water may increase the rate of consumption and the intermittent system of supply leads to less consumption of water.

1.1.6 Population :

The total number of human beings residing in an area is taken as population. Population is an important factor for the estimation of a water supply project. Hence it is necessary to predict the future population with the help of any suitable method. Usually the population will be predicted in terms of decades. A decade contains of ten years. Normally the design period of a water supply project varies from 30 years to 50 years.

1.1.6.1 Prediction of Population:

The design of water supply project is not designed only for present population. But it is made to accommodate the future population. Hence it is necessary to predict the future population. The following methods are adopted to forecast the future population.

1. Arithmetical increase method
2. Geometrical increase method
3. Incremental increase method
4. Graphical method
5. Zoning method
6. Comparative method

1. Arithmetical increase method:

In this method, the average increase of population for the last three or four decades is worked out and then for each successive future decade, this average is added. This method gives low results and it is adopted for the towns which reach maximum development.

Population after decades (P future) = Present population + Average increase in Population

2. Geometrical increase method:

In this method, it is assumed that the percentage of increase in population from decade to decade is assumed as constant. From the available census data, the percentage is fixed and then population of each future successive decades is worked out. The fixation of percentage in case of developing towns should be done carefully. Otherwise this method is likely to give high values. This method is suitable for old towns which are not undergoing future development.

$$\text{Population after decades (P future)} = \left[\text{Present population} + \left(\text{Present population} \times \frac{\text{Average percentage of increase}}{100} \right) \right]$$

3. Incremental increase method:

The population of each successive future decade is first worked out by arithmetical increase method and to these values, the average incremental increase of decade is added. It thus gives satisfactory results for any place.

Population after decade (P future) = Present Population + Average Increase + Average

Incremental Increase

4. Graphical Method:

In this method, the future population is assessed from a curve of a graph drawn between population and years. In the graph the years are taken in 'X' axis and population in 'Y' axis and a curve is drawn from the known census records. The future population is estimated from the extension curve from the present population. The results of this method influence the personal judgment of extension of curve.

5. Zoning method:

In this method, the master plan of a town is prepared and it is divided into several zones such as residential zone, industrial zone, commercial zone, etc. The town is allowed to grow in a definite way only. Thus the future population of a town when fully developed can easily be worked out. In this method, if we consider the residential zone, the maximum number of houses to be allowed is 1000. Assuming 5 persons in a house, the population of this zone when fully developed will be about 5000. Accordingly summing up of various zones gives the total population.

6. Comparative method:

In this method, it is assumed that the town under consideration will develop as similar towns developed in the past. It is thus assumed that the future population growth of this town under consideration will parallel the past growth of similar town. Practically it is difficult to identify the similar towns with respect to population growth. If statistics of development of similar towns are available, the result obtained by this method may prove to be reliable and satisfactory.

Model Problem of Estimation of Population

Problem

The census records of a town show population as follows:

Present	-	50000
Before One decade	-	47000
Before Two decades	-	43500
Before Three decades	-	41000

Calculate the probable population after one, two and three decades by using

- Arithmetical increase method
- Geometrical increase method
- Incremental Increase method.

Year	Population	Increase	Percentage of Increase	Incremental Increase
Before three decades	41000	-	-	-
Before two decades	43500	2500	6.10	-
Before one decade	47100	3600	8.30	+1100
Present	50000	2900	6.16	- 700
	Average	$9000/3 = 3000$	$20.56/3=6.85\%$	$+400/2=200$

Model Calculation

Increase can be the difference between successive decades i.e. $43500 - 41000 = 2500$

Percentage of increase can be calculated as

$$\frac{\text{Increase}}{\text{Population in previous year}} \times 100 = \frac{2500}{41000} \times 100 = 6.10\%$$

Incremental increase can be calculated by subtracting the successive two decades from bottom to top and the positive and negative signs are also to be considered.

$$[2900 - 3600 = -700 \text{ and } 3600 - 2500 = +1100]$$

Arithmetical Increase method:

1. Population after one decade = Present Population + Average Increase
= $50,000 + 3,000 = 53,000$
2. Population after two decades = $53,000 + 3000 = 56,000$
3. Population after three decades = $56,000 + 3000 = 59,000$

Geometrical Increase Method:

1. Population after one decade = $\left[\text{Present population} + \left(\text{Present population} \times \frac{\text{Average percentage of increase}}{100} \right) \right]$
= $\left[50000 + \left(50000 \times \frac{6.85}{100} \right) \right] = 53425$
2. Population after two decades = $\left[53425 + \left(53425 \times \frac{6.85}{100} \right) \right] = 57084.61$
3. Population after three decades = $\left[57084.61 + \left(57084.61 \times \frac{6.85}{100} \right) \right] = 60994.91$

Incremental Increase Method

1. Population after one decade
= Present Population + Average Increase + Average Incremental Increase
= $50000 + 3000 + 400 = 53400$
2. Population after two decades = $53400 + 3000 + 400 = 56800$
3. Population after three decades = $56800 + 3000 + 400 = 60200$

1.1.7 Sources of Water

To make success of water supply scheme, it is also necessary to have adequate sources of water supply. In fact two aspects of scheme namely, demand of water and available quantity of water should balance each other. Thus the availability of required quantity of water to meet the requirement of demand is known as water supply source.

1.1.7.1 Types of Sources

The chief source of water supply is rainfall. From this, the water is also available in the following forms.

- I. Surface sources
- II. Underground (or) Sub Surface Sources

I. Types of Surface sources;

- 1. Lakes and streams
- 2. Rivers
- 3. Storage reservoirs

1. Lakes and streams

It represents the large quantity of water enclosed in land. The available quantity of water is enough to meet the requirements of nearby places. Hence, it is chosen as surface source. The water which is available from lakes and streams is generally free from undesirable impurities and can therefore be safely used for drinking purpose.

2. Rivers:

The flowing of huge quantity of water from one place to another place is called as river. The river may be perennial and non-perennial. Depending upon the availability of water, the river, may be taken as sources of water supply. Generally, the quantity of water from river is likely to fall down in summer season when demand of water is high. Hence care should be taken to choose river as water supply source.

3. Storage reservoir:

An artificial lake formed by the construction of dam across the valleys is termed as a storage reservoir. At present reservoir is the main source of water supply for big cities. It is also called as impounding reservoir.

II. Underground (or) Sub surface sources:

The following are the types

- 1. Infiltration galleries
- 2. Infiltration wells

3. Springs
4. Wells
 1. Shallow well
 2. Deep well
 3. Bore well
 4. Artesian well

1. Infiltration gallery:

An infiltration gallery is a horizontal or nearly horizontal tunnel which is constructed through water bearing strata. It is also referred as horizontal well. The gallery is usually constructed of brick walls with slab roof. The gallery obtains water from water bearing strata by various porous drain pipes. These pipes are covered with gravels, pebbles, etc. so as to prevent the entry of very fine materials into pipe.

The gallery is laid at a slope and the water collected in the gallery is led to a sump from where it is pumped and supplied to consumers after proper treatment.

The man holes are provided along the infiltration gallery for the purposes of cleaning and inspection.

The infiltration gallery is useful as sources of water supply when ground water available is in sufficient quantity.

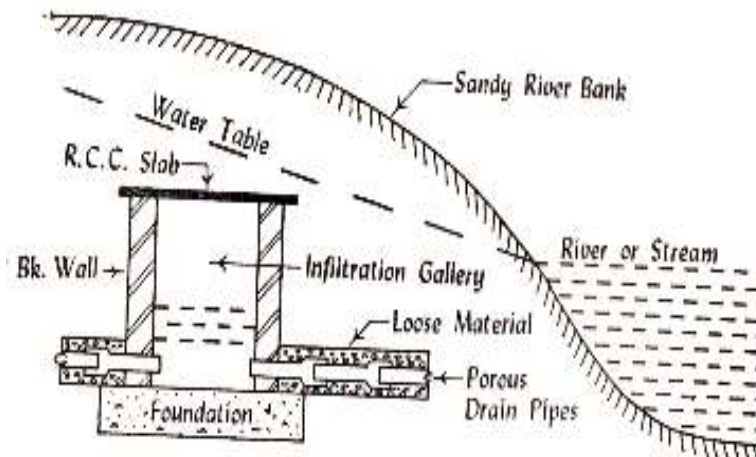

Fig – 1.1 -Infiltration gallery

2. Infiltration Wells:

In order to obtain large quantity of water, the infiltration wells are sunk in series in the bank of river. The wells are closed at the top and open at the bottom. They are constructed of brick masonry with open joints. For the purpose of inspection of well, manholes are provided in the top

cover. The infiltration wells in turn are connected by porous pipes to a collecting sump, known as jack well. The water from the jack well is pumped to purification plant for treatment.

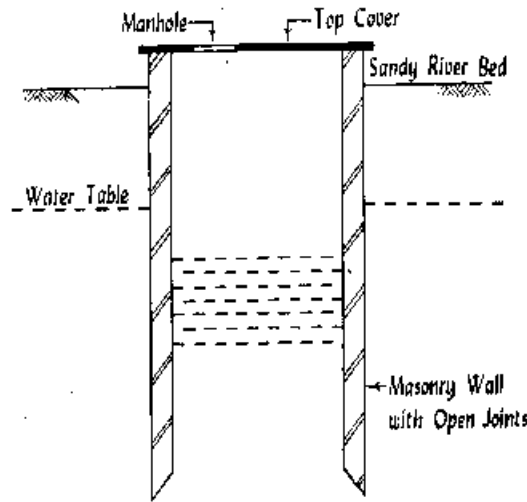

Fig – 1.2 –Infiltration well

3. Springs:-

When ground water appears at the surface automatically by any reason springs are formed. They serve as source of water supply for small towns, especially near hills or base of hills.

The following are the types of springs

- i) Artesian Spring
- ii) Gravity Spring
- iii) Surface Spring

i) Artesian Spring

In this type of spring the ground water comes to the surface under pressure. The artesian spring may also be formed due to presence of fissure or crack continued up to ground surface. The artesian springs give practically uniform quantity of water throughout the year.

ii) Gravity Spring

This type of spring develops due to overflowing of the water table. The flow from a gravity spring is variable with the rise or fall of water table. In order to meet such fluctuations, a trench may be constructed near such a spring. The trench acts as a storage reservoir.

iii) Surface Spring:

This type of spring is formed when subsoil water is exposed to the ground surface by the obstruction of impervious layer. The quantity of water available from the surface spring is quite uncertain and cut off walls may be constructed to develop such springs.

4. Wells:

A well is defined as an artificial hole or pit made in the ground for the purpose of tapping water. In India 75 percentage of population depends on wells for its water supply. The following are the types of wells.

1. Shallow Well
2. Deep Well
3. Bore Well
4. Artesian Well

1. Shallow Well:

The shallow wells are constructed in the uppermost layer of earth's surface. They obtain water from the ground water table. The diameter of shallow wells varies from 2 to 5 meters. They may be lined or unlined from inside. The lining is called steining and its thickness varies from 30 cm to 50 cm. The unlined wells are generally constructed up to a maximum depth of 7m. But for greater depths, the soil cannot stand vertically and hence, steining becomes essential for such wells. These wells are also sometimes, referred as draw wells or gravity wells.

The quantity of water available from shallow wells is generally limited as their source of water supply is the uppermost layer of earth only.

The quality of water obtained from shallow wells is better than river water. But it is not reliable and it requires purification.

2. Deep Wells:

The deep wells obtain water from an aquifer below an impervious layer. The theory of deep well is based on the travel of water from the outcrop to the site of deep well. The out crop is the place where aquifer is exposed to surface. The entry of rain water takes place through the outcrop and it reaches to the site of deep well. During its travel the water gets thoroughly purified. The water of deep wells is contained in lower embedded aquifers and always available at a pressure greater than atmospheric pressure. The deep wells are therefore referred as pressure wells.

3. Bore Well:

A bore well is a deep well having a diameter of about 50 mm and to 200 mm and it obtains water from a number of aquifers. The blind pipes are placed against impervious layer. The quantity of water available from a tube or bore well is generally sufficient and more or less reliable. The discharge from a tube well does not exceed 40 to 50 liters per second. The quality of bore well water is generally very good and can be used without any treatment.

4. Artesian Well:

This type of well derives its name from the fact that the first such well was sunk in the province of Artois in France. The theory of working of artesian wells is based on the principles of hydraulics that the water tends to remain at the same level. The quantity of water available from an artesian well is plentiful and it can be used with advantage when artesian conditions exist. The quality of water available from artesian well is found to be pure and does not require any treatment.

5. Aquifer:

It is observed that the surface of earth consists of alternate courses of pervious and impervious strata. The pervious layer permits to pass water and hold water. Such pervious layer is termed as aquifer or water bearing strata.

6. Water table:

The upper surface of free water in top soil is termed as ground water table (or) water table. The level of water table is variable. It rises in wet season and falls down in dry season.

1.8 Quantity of Water:

It can be easily arrived after assessing the population of the area either by census or any mathematical methods and it's situational per capita demand. This quantity of water enables to identify the suitable sources of water supply for a town or village. Hence

Total quantity of water required for a village or town = Population × Rate of demand

www.binils.com

1.2 INTAKES AND CONVEYANCE

(1.2: Intakes - types of intakes-description of intakes-infiltration galleries and infiltration wells in river beds - necessity of pumps - types of pumps - pipes for conveyance of water - cast iron, steel, G.I., cement concrete, R.C.C., Hume and PVC pipes-pipe joints -laying and testing of pipe lines - pipe corrosion - corrosion control)

1.2.1 Intakes:

Intake is a structure constructed by any kind of masonry so as to withdraw water from the sources of water supply such as lakes, canals, rivers and reservoirs. The following are the types of intakes

1. Canal intake
2. River intake
3. Reservoir intake

1. Canal intake:

An intake chamber is constructed in the section of canal. This results in the reduction of waterway which increases the velocity of flow. The entry of water in the intake chamber takes through the coarse screen and the top of outlet pipe is provided with fine screen. The inlet and outlet pipe is of bell mouth shape with perforations of fine screen on its surface. The outlet valve is operated from the top and it controls the entry of water into the outlet pipe.

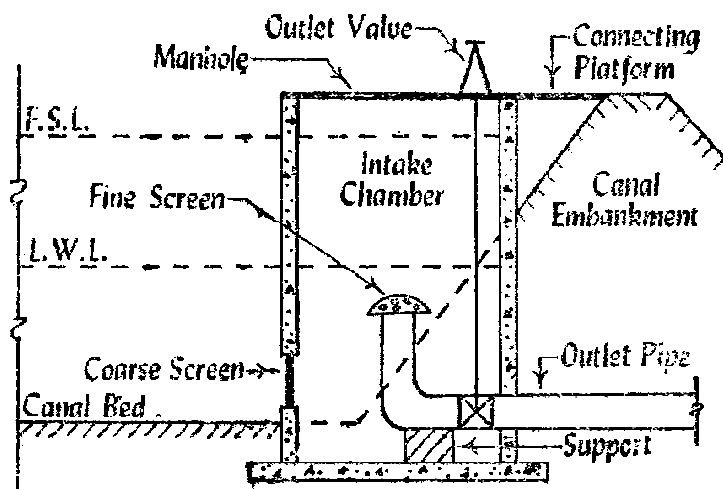

Fig 1.3 – Canal intake

2. River intake:

An approach channel is constructed to lead the water from the upstream side of the river to the jack well. The penstocks with screens are provided at different levels. The suction pipe is provided with strainer at its lower end. The water from the jack well is pumped and sent to the treatment plant.

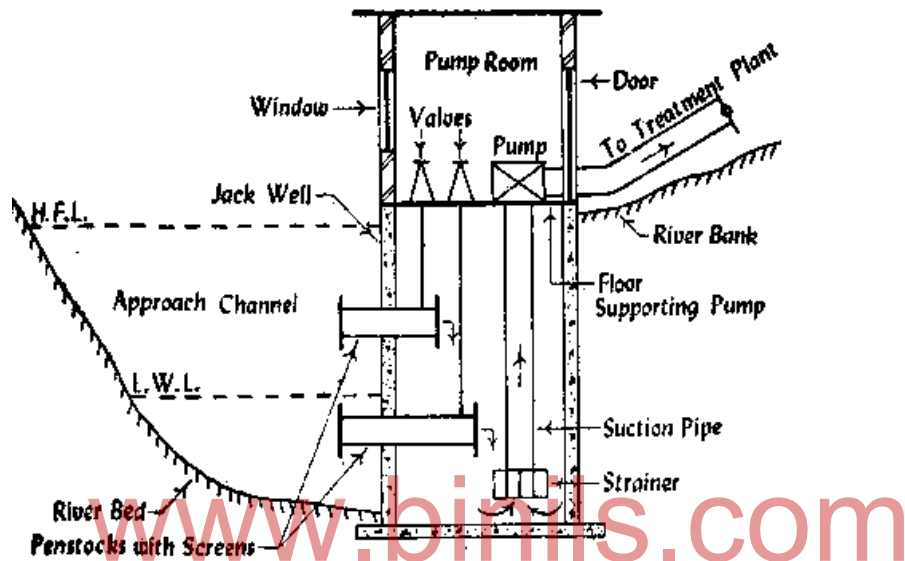

Fig 1.4 – River intake

3. Reservoir intake:

It consists of an intake well which is placed near the dam. It is connected to the top of the dam by a foot bridge. The intake pipes are located at different levels with a common vertical pipe. The valves of intake pipes are located and operated from the top and they are installed in a valve room. Each intake pipe is provided with bell mouth entry with perforations of fine screen on its surface. The outlet pipe is taken out through the body of the dam. Outlet pipe is suitably supported. Location of the intake pipes at different levels ensures supply of water from a level lower than the surface level of water. When the valve of an intake pipe is opened, the water is drawn off from the reservoir to the outlet pipe through the common vertical pipe.

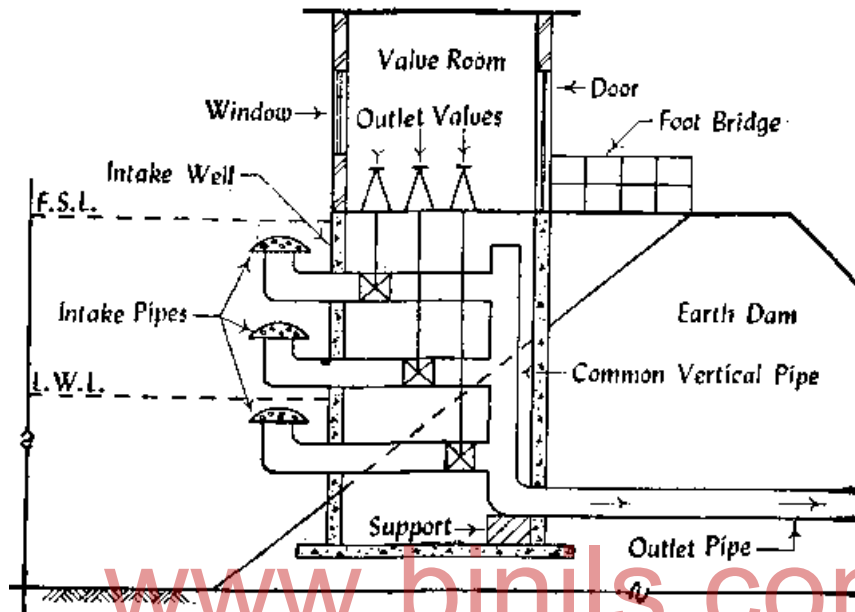

Fig 1.5- Reservoir intake

1.2.2. Pumps

A mechanical device in which the water lifted at increased pressure by creating vacuum into pipe is known as pump. The process of using pump is known as pumping.

1.2.2.1 Necessity of pumps:

The following necessity acquires to use pumps in water supply scheme.

1. To increase pressure at certain points in the distribution system.
2. To lift water from lower elevation to higher elevation.
3. To lift raw water from various sources for taking it to treatment plant.
4. To make water available at higher pressure during certain processes of treatment.
5. To distribute water into the distribution system with required pressure.

1.2.2.2 Types of pumps:

Majorly, the pumps are classified according to the mechanical principles involved in the working of pumps. The following are the classifications:

1. Air lift pump
2. Centrifugal pump
3. Displacement pump – Reciprocating pump & Rotary pump
4. Hydraulic pump and
5. Jet pump

1. Air lift pump:

In this type of pump, compressed air is used to lift water. The air pipe supplies the compressed air from the compressor. This compressed air is then released through an air diffuser. The air diffuser is located at the bottom of the educator pipe. The air rises in small bubbles in the educator pipe and it forms a mixture of air and water. This mixture has low specific gravity than that of water and the pressure in the educator pipe becomes less than the pressure in the casing pipe. This difference of pressure lifts water into the educator pipe and finally results in water coming out through the outlet.

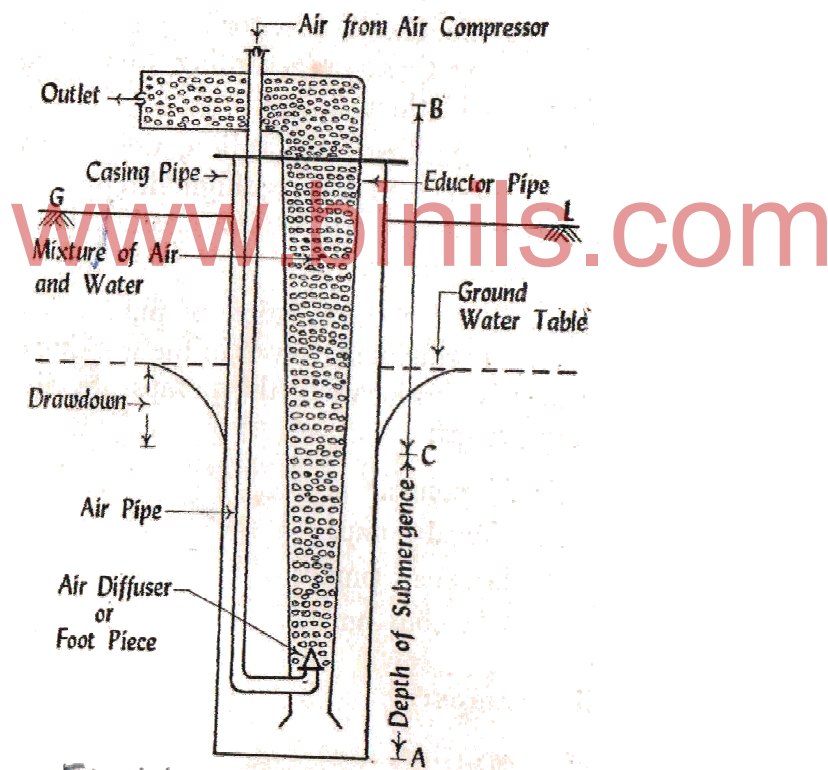

Fig 1.6 – Air lift pump

2. Centrifugal pump

This type of pump works on the principle that when a vessel containing liquid is rotated about a point, centrifugal forces causes the liquid level to rise. The centrifugal pumps are divided into two groups – volute type and turbine type.

In volute type of centrifugal pumps, the impeller discharges water into a gradually expanding spiral chamber. This chamber is designed in a way that the velocity of flow in it remains uniform. The conversion of velocity head into pressure head takes place in this chamber.

In turbine types of centrifugal pump, a fixed diffusion ring is inserted between impeller and casing. The diffusion ring contains opening through which water is led into casing. These pumps are less popular

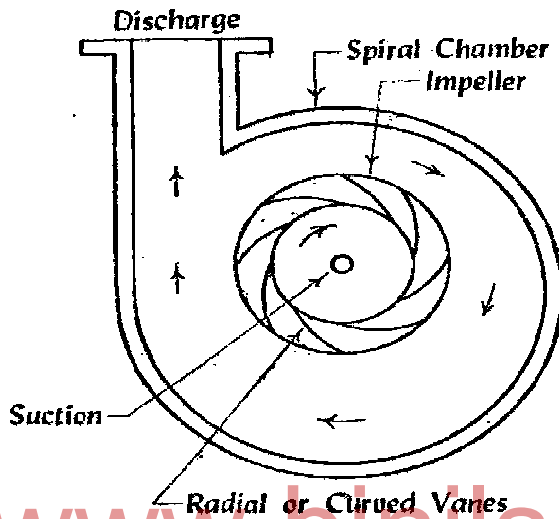

www.binils.com

Fig 1.7 (a) – Centrifugal pump – volute type

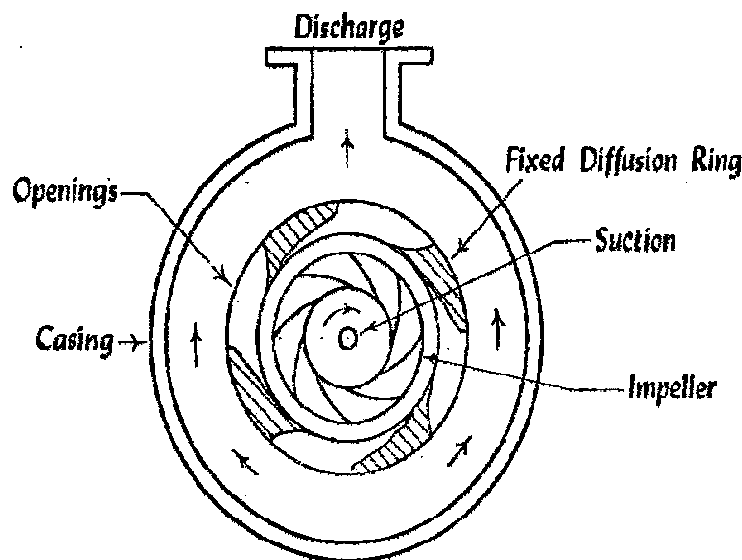

Fig 1.7 (b) – Centrifugal pump – turbine type

3. (i) Reciprocating pump:

In this type of pump, a piston or plunger moves inside a closed cylinder. On the intake stroke, the suction valve remains open and allows water to come into cylinder. The delivery valve remains closed during the intake stroke. On the discharge stroke, the suction valve is closed and the water is forced in delivery pipe through the delivery valve which opens during discharge stroke. This type of pump is broadly classified as single acting and double acting pumps.

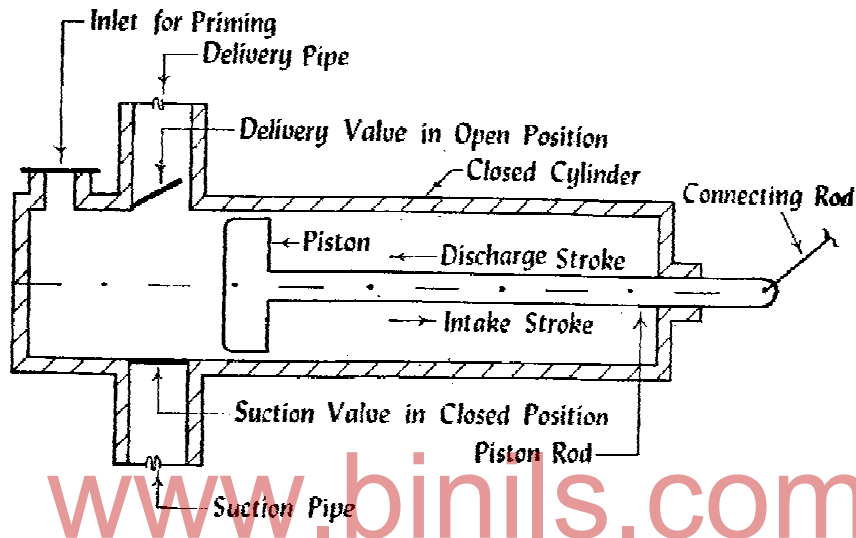

Fig 1.8 – Reciprocating pump

3(ii) Rotary Pump:

In this type of pump, the reciprocating motion is substituted by the rotary motions. The rotary motion is achieved by cams or gears.

4. Hydraulic ram:

In this type of pump, at beginning, the water enters the ram through inlet pipe. At this stage the delivery valve is closed and the waste valve is kept open. The waste valve is known as impetus valve.

5. Jet pump:

In this type of pump, a nozzle is placed at the throat of a venture tube and it discharges either compressed air or steam or water at high velocity. The jet causes suction and water is drawn from suction pipe. The high velocity of mixture is converted into pressure head and water is raised in the discharge pipe.

1.2.3 Pipes

The water can be transported either through gravity or pressure conduits. The gravity conduits are in the form of open channels and the water is conveyed under atmospheric pressure. The pressure conduits are in the form of pipes and the water is conveyed under pressure.

The following are the various materials used to make pipes.

1. Asbestos pipe
2. Cast – Iron pipe
3. Cement Concrete pipe
4. Copper pipe
5. Galvanized Iron pipe
6. Lead pipe
7. Plastic pipe – PVC pipe
8. Steel pipe
9. Wood pipe
10. Wrought – Iron pipe
11. Hume pipe
12. RCC pipe

1. Cast – Iron pipe:

These pipes are extensively used for conveyance of water. These are available in size up to diameter of about 120 cm or more.

Advantages

- i) The cost is moderate
- ii) The pipe is easy to join
- iii) The pipes are less corrosive in nature
- iv) The pipes are strong and durable
- v) The service connections are easily made
- vi) The life period under normal condition is about 100 years or so.

Disadvantages

- i) The breakages are large.
- ii) The carrying capacity of these pipes decreases with the increase in life of pipes
- iii) This pipes are not used for pressures greater than 7 kg per cm²
- iv) The pipes are heavier and uneconomical

2. Steel pipes:

The mild steel is used to produce steel pipes. The joints of steel pipes are either riveted or welded. These pipes are used for pipes having diameter greater than 120 cm. The inside and outside surface of steel pipes are generally galvanized.

Advantages:

- i) Available in long lengths and hence requires less number of joints.
- ii) Initial cost is less
- iii) Durable and strong to resist high internal pressure
- iv) Flexible to some extent while laying in curve
- v) Light weight makes easier to transport.

Disadvantages:

- i) Maintenance cost is high
- ii) High corrosive nature
- iii) Not suitable for distribution pipes, this requires more time to repair
- iv) Deform its shape under combined action of external and internal loads.

3. Galvanized Iron pipe(G.I)

These pipes are widely used for service connections and their diameter varies from 6 mm to 75 mm.

Advantages:

- i) Less cost, light weight, easy to handle and transport.
- ii) Easy to join.

Disadvantages:

- i) Corrosive nature
- ii) Less durability

4. Cement Concrete:

The plain cement concrete pipes are used for low heads up to about 15 m. It is available in diameters varying from 50 cm to 250 cm

Advantages:

- i) Inside surface can be made smooth
- ii) Moderate durability
- iii) Can be cast in site, so less transportation
- iv) No danger of corrosion

Disadvantages

- i) Lack in tensile strength and unable to withstand high pressure
- ii) Heavy in weight and difficult to handle
- iii) Repairs are difficult

5. R.C.C Pipes:

The R.C.C Pipes consist of rings or hoops and longitudinal steel bars. The reinforcement is placed in the mould and the cement concrete is then poured into it. It is available in diameters varying from 50 cm to 250 cm.

Advantages:

- i) Smooth inside surface
- ii) High durability
- iii) Less in corrosion
- iv) Less maintenance cost
- v) Withstand moderate pressure

Disadvantages:

- i) High initial cost

6. (RCC) Hume Pipes:

The mould of RCC after pouring concrete is rotated with great speed around its longitudinal axis. These are known as hume pipes (or) spun pipes and they are widely adopted in the conveyance of water.

Advantages:-

- i) Smooth inside surface
- ii) Less maintenance cost
- iii) High durability
- iv) No corrosion
- v) Withstand high pressure

Disadvantages:

- i) Initial cost is high
- ii) Requires transport cost

7. PVC Pipes:

It is made from polyvinyl chloride. It is a material used in modern age. Its various uses in many fields have made it very popular

Advantages:-

- i) Less weight and easy handling.
- ii) No corrosion
- iii) Withstand high pressure
- iv) Less initial & maintenance cost
- v) Better durability

Disadvantage:-

- i) Lack to withstand external load.

1.2.4 Pipe Joints:

In order to make a pipe to many kilometers length, different methods of joints are used. The following methods are widely adopted.

- i) Bell and spigot joint
- ii) Expansion joint
- iii) Flanged joint
- iv) Collar joint
- v) Open joint

1. Bell and spigot joint:

The spigot is smaller diameter and it is inserted into a larger diameter bell end. The hemp is used to maintain the alignment of pipes and molten lead is then poured to finish up the joint.

2. Expansion joint

It is used when pipes are subjected to severe changes in temperature. A rubber gasket is inserted between the spigot and bell ends to make the joint as water tight. The flanged ring is bolted to bell and it expands or contracts along with bell end.

3. Flanged joint:

It is used for carrying water at high pressure. The ends of the pipe are provided with wide flanges which are belted together. A hard rubber gasket is inserted between the flanges to make the joint as water tight.

4. Collar joint:

The Collar is slightly greater than pipe used to make this joint. The hemp or jute rope is inserted between the pipes to make alignment. The cement mortar is used to make the joint as water tight.

5. Open joint:

The joint in pipes made without any inert materials are called open joints. This type of joint is used where the percolation is required.

1.2.5 Laying and Testing of Pipes:

The following steps are involved in the laying of pipes

1. Setting out alignment
2. Excavation of trenches
3. Laying and jointing
4. Testing
5. Back filling

1. Setting out alignment:

The centre line of the pipe is marked along the places where the pipe lines are laid. The marking is started from the distribution end to the head works. Pegs are fixed at regular and required intervals along the centre line. The width of excavation is marked across the centre line.

2. Excavation:

The trench is excavated. In soft soil, timber bracing is done. Where the subsoil water seeps in the trench, dewatering has to be done. In soft soil, bed concrete is to be provided to accommodate pipes.

3. Laying and jointing

The centre line and invert level are marked by driving pegs in the trench. A string is stretched along the top of the pegs. In all the way the centre line is carried to the ground to bed the pipe. In soft soil, a concrete bed is laid at the bottom to support pipe. In hard soil, no support is required. The pipes are laid to the proper alignment and suitable joints are made in the pipes.

4. Testing:

The newly laid pipes are tested before use. The common tests adopted are

1. Water test
2. Straightness test
3. Obstruction test
4. Smoke test

1. Water test:

This test is conducted to ascertain the water tightness. The lower end of the pipes is closed. Water is filled in the pipe line through the upper end. The water is subjected to certain test pressure. Seepage of water is greater than the permissible value, the weak point is located and rectified

2. Straightness test:

A light is placed at the one end of the pipe line and a mirror is placed at the other end of pipe line. If the light is seen clearly in the mirror, there is no obstruction. The obstruction, if any, is indicated in the mirror.

3. Obstruction Test:

A ball of diameter just lesser than the pipe is allowed to roll down in the pipe line. The ball will roll down and appear at lower end it indicates that there is no obstruction. Otherwise the obstruction is spotted and rectified.

4. Smoke test:

This test is conducted in house pipe lines and the pipes are laid above the ground. Smoke under pressure is allowed in the pipe for about 15 minutes. If the smoke is noticed escaping from some weak point or joint, the same is spotted and rectified.

5. Back Filling:

After all the pipes are laid properly and tested, the trenches are refilled with the excavated earth. Filling is done in layers of equal depth on both sides of the pipe. Each layer is watered and rammed. This is done till the original surface is restored.

1.2.6. Pipe Corrosion:

It is the loss of pipe material due to action of water and the earth placed over and around the pipe. The internal corrosion is made due to the flowing water and the external corrosion is made due to the water logging soil.

1.2.6.1 Effects of pipe corrosion:

The following are the effects of pipe corrosion

- i) The pipe corrosion may lead to tuberculation which is phenomena of the formation of small projections on the inside surface of pipe and they decrease the cross sectional area and thus carrying capacity is affected.
- ii) The pipe corrosion leads to the disintegration pipe line and it requires heavy repair.
- iii) The pipe corrosion imparts color, taste and odour to the flowing water.
- iv) The pipe connections are seriously affected by the action of pipe corrosion.
- v) The pipe corrosion may make the water dangerous for drinking and other purposes

1.2.6.2 Prevention or Minimize or control the pipe corrosion:

Practically it is not possible to completely eliminate the pipe corrosion. But the following measures can bring down the corrosion to some extent.

1. Treatment of water
2. Proper pipe material
3. Protective linings
4. Cathodic protection.

1. Treatment of water:

The water should be given proper treatment to prevent pipe corrosion. The usual treatments employed are adjustment of pH, control of calcium carbonate, removal of dissolved oxygen and carbon di-oxide, addition of sodium silicate etc..

2. Proper pipe material:

The selection of proper material may reduce the pipe corrosion. The alloys of iron or steel with chromium, copper or nickel are found to be more resistant to pipe corrosion. Also plastic type pipes may reduce corrosion.

3. Protective linings :

The surface of the pipe may be coated with anti corrosive linings. The usual coatings employed are those of asphalt, bitumen, cement mortar, paints, resins, tar, zinc etc. The degree of prevention achieved will depend on the individual properties of coating material.

4. Cathodic protection:

If the entire pipe line acts as cathode, the pipe corrosion may be minimized. This is achieved by connecting the pipe line either to the negative pole of a D.C. generator or to anodic metals like magnesium. The emerging currents from anodic areas are neutralized and the corrosion is prevented. The cathodic treatment is the most effective. But it is too expensive and involves many practical difficulties.

1.3. QUALITY OF WATER

(1.3: Impurities in water - Testing of water - Collection of water sample - Physical, Chemical, Bacteriological tests - Standards of drinking water - water borne diseases and their causes)

1.3.1 Pure Water or Whole some or Potable water

The public water supply requires pure or potable or wholesome water. (i.e.) fit for drinking. The water which is not physically or chemically pure but is fit for dinking is called wholesome water.

1.3.2 Impurities in water:

It is difficult to find pure water in nature. When the rain water descends to the ground it absorbs dust and gases form air. It further absorbs organic and inorganic matter at the ground surface. These are called impurities in water. The following are the types of impurities in the water.

1. Physical impurity
2. Chemical impurity
3. Bacteriological impurity

Further, the above impurities are divided into suspended, dissolved and colloidal impurities. Furthermore these are classified into organic and inorganic impurities. The following analysis are adopted

1. Physical Analysis or Test
2. Chemical Analysis or Test
3. Bacteriological analysis or Test

1. Physical test:

The following parameters are mostly adopted to determine the physical impurities.

1. Colour
2. Taste and odour
3. Temperature
4. Turbidity

1. Colour:

The presence of excessive colloidal impurities imparts colour to water. It spoils and affects cloths and various industrial processes. The measurement of colour is made by an equipment called tintometer.

This instrument has an eye piece with two holes. A slide of standard coloured water is seen through one hole and in the other hole, the slide of water to be tested is inserted. The intensity of the colour of water is measured on an arbitrary scale. The unit of colour is cobalt scale. Permissible value of color should not exceed 20 but preferably less than 10.

2. Taste and odour

The water possesses taste and odour due to various causes such as its place and presence. It makes water unpleasant for drinking. This is carried out by inhaling through two tubes of an osmoscope. One tube is kept in a flask containing diluted water and the other one contains the water to be tested. The unit of taste & odour is mere number. For public water supply, the number should not exceed 3.

3. Temperature:

The test for temperature has no practical meaning in the sense that it is not possible to give any treatment to control the temperature in any water supply project. The temperature mainly depends upon the depth where it is drawn. The desirable temperature of potable water is 10°C while the temperature of 25°C is considered to be objectionable.

4. Turbidity

The excessive presence of colloidal matters imparts turbidity to water. The unit of turbidity is expressed in ppm or mg per litre. The permissible value of turbidity for drinking water is 5 to 10 PPM. The tolerable limit is 20 ppm. The following methods are adopted to find the amount of turbidity present in water.

1. Turbidity rod
2. Jackson candle turbidimeter
3. Baylis turbidimeter
4. Nephro turbidimeter

The excessive presence of turbidity in water imparts colour and pollution. It does not permit the light rays to pass into it.

2. Chemical Test:

The following parameters are to be assessed in this type of test.

1. Chlorides
2. Dissolved gases

3. Hardness
4. pH – Hydrogen ion concentration
5. Metals and other chemical substances
6. Nitrogen and its compounds
7. Total Solids

1. Chlorides:

The chloride contents especially of sodium chloride or salt are worked out for a sample of water. The excessive presence of sodium chloride indicates pollution of water. For potable water, the amount of chlorides should not exceed 250 mg per litre.

2. Dissolved gases:

The water contains various gases from its contact with atmosphere and ground surfaces. The usual gases are nitrogen, methane, hydrogen sulphide, carbon di oxide and oxygen. The contents of these dissolved gases in a sample of water are suitably worked out. Among the various gases, the presence of oxygen into water is mostly considered. The amount of potable water should be about 5 to 10 ppm.

3. Hardness:

The presence of bicarbonates of calcium and magnesium and chlorides, sulphates and nitrates of calcium and magnesium imparts hardness to water. It is also called as soap destroying power. It is classified as temporary and permanent hardness. Temporary hardness is called carbonate hardness and permanent hardness is called non – carbonate hardness. It is expressed in terms of ppm or degrees. The permissible value of hardness is about 5 to 8 degrees or 112.5 ppm.

4. Hydrogen ion concentration: (pH)

The study of presence of hydrogen ion into water is called as pH. The acidity or alkalinity of water is measured in terms of pH. The water becomes acidity when hydrogen ion is greater than hydroxyl ion. In the reverse, it indicates alkaline. When hydrogen ion is equal to hydroxyl ion then pH value is neutral i.e. called distilled water. The pH is measured by using pH scale between 0 & 14. For potable water the pH value should be 7 to 8.50. Colourimetric and electrometric methods are used to determine the pH.

5. Metals and its substances:

The presence of various metals along with chemical substances into water is objectionable. Some of the metals are Arsenic, Barium, Calcium, Copper, Cyanide, Fluoride, Iron, Lead, Manganese, Sulphate, Zinc etc.

6. Nitrogen and its compounds:

The presence of nitrogen in various forms in water is considered in the water supply scheme. The following are the forms

1. Free ammonia
2. Albuminoid ammonia
3. Nitrites
4. Nitrates

The permissible values of free ammonia should not exceed 0.15 ppm, albuminoid ammonia should not exceed 0.30 ppm. There should be no presence of Nitrites in water and the presence of Nitrates should not exceed 45 ppm.

7. Total Solids:

The adding of total suspended solids and total dissolved solids present into water gives the total solids of water. The presence of total solids into water is less than 500 ppm and should not exceed 1000 ppm.

3. Bacteriological test:

The consideration of presence of bacteria is very important. The bacteria are tiny organisms and it is difficult to find through even microscope. The presence of pathogenic and no pathogenic bacteria is important in the point of water supply. The following methods are used to determine the presence of bacteria

1. Total count test
2. B – Coli (or) E – Coli test

1. Total count test:

In this test, the bacteria are cultivated on agar plate for different dilutions of sample of water with sterilized water. This sample is placed in an incubator for 24 hours at 37°C or 48 hours at 20°C. These represent hot count and cold count respectively. Thus the colonies of bacteria which are formed are then counted and then computed for 1 CC. For potable water, the total count should not exceed 100 per cc.

2. B.Coli test: (E.Coli)

This test is conducted in three steps.

1. Presumptive test
2. Confirmed test
3. Completed test

i) Presumptive test:

The following procedure is adopted in this test.

1. The definite volumes of diluted samples of water are taken in multiples of ten such as 0.1 cc, 1.0 cc, 10 cc etc.

2. The sample is placed in standard fermentation tube containing lactose broth.
3. The tube is placed at a temperature of 37°C for 48 hours.

If a gas is seen in the tube after this period is over, it indicates the presence of 'B-Coli'. If gas is absent it indicates that the water is fit for drinking.

ii) Confirmed test:

A small portion of lactose broth showing positive presumptive is carefully transferred to another fermentation tube containing brilliant green lactose bile. If gas is seen in the tube after 48 hours, the result is considered positive and completed test becomes essential.

iii) Completed test:

This test is made by introducing bacterial colonies into lactose broth fermentation tubes and agar tubes. The incubation is seen after this period. It indicates positive result and further detailed tests are carried out to detect the particular type of bacteria present in water. The absence of gas indicates that the water is safe for drinking.

1.3.3. Water borne diseases:

The water is an important carrier for carrying and spreading dangerous diseases. The following are some of diseases.

1. Cholera
2. Dysentery
3. Typhoid
4. Hepatitis
5. Tuberculosis
6. Gastro – enteritis
7. Poliomyelitis etc....

www.binils.com

Causes of water borne diseases:-

1. The presence of bacteria, virus and protozoa causes water borne diseases
2. The water contaminated with sewage is the one of the sources of water borne diseases.
3. The patients suffering from water borne diseases give out organism responsible for water borne diseases.

Prevention of water borne diseases:-

1. The disinfection of water may reduce water borne diseases
2. The frequent checking of water lines may reduce water borne diseases
3. The public are advised to keep the environment clean to avoid water borne diseases

4. The nuisance caused by flies is to be controlled
5. Proper water treatment may reduce water borne diseases.

1.3.4 Water Sampling:

Before the sample collection, field personnel must take steps to ensure that the samples collected will be representative of the aqueous system being in the rest of field. The following precautions are to be taken while collecting water sampling

1. The water should be collected in white bottles having well – fitted stoppers
2. Bottles having capacity 2 litres of water are used for chemical analysis of water.
3. Bottles should be thoroughly cleaned, filled thrice with water and emptied thrice before collecting the sample.
4. When a sample of water is to be collected from a pipe, the water tap should be turned on and the water should be allowed to go waste for at least two minutes so as to prevent the entry of undesirable elements.
5. If the sample is collected for bacteriological analysis, the nozzle of pipe should be flamed and cooled before collecting the sample.
6. For collecting the sample of water from lake, stream, spring or well, the bottle with stopper closed should be suspended well under the surface of water.
7. In no way, the water entering the bottle should come in contact with the hand.
8. The bottles containing sample of water should be labeled stating source, date and time of collection.

1.3.5. WHO STANDARDS

The following standards of quality drinking water are based on U.S. Public Health Service Standards of **World Health Organization** (WHO) recommendations.

1.3.5.1 Physical Characteristics

S.No.	Physical Characteristics	Requirement (Acceptable Limits)
1.	Colour	10 to 20 Preferable : Less than 10 Platinum cobalt scale
2.	Odour	0 value
3.	Taste	No objectionable taste
4.	Temperature	10°C to 16°C
5.	Turbidity	5 to 10 ppm, Preferable: Less than 5 ppm (Silica scale)

1.3.5.2 Chemical Characteristics

S.No.	Chemical Characteristics	Requirement (Acceptable Limit)
1.	Arsenic	0.05 ppm (maximum)
2.	Alkalinity	120 ppm (maximum)
3.	B.O.D	Nil
4.	Chlorides	250 ppm (maximum)
5.	Copper	1 to 3 ppm
6.	Dissolved Oxygen	5 to 6 ppm
7.	Fluorides	1.5 ppm (maximum)
8.	Hardness	75 to 115 ppm (Hardness expressed as carbonate)
9.	Hexavalent chromium	0.05 ppm (maximum)
10.	Iron and manganese	0.03 ppm (maximum)
11.	Lead	0.1 ppm (maximum)
12.	Magnesium	125 ppm (maximum)
13.	Nitrite nitrogen	Nil
14.	Nitrate nitrogen	45 ppm (maximum)
15.	Organic nitrogen	0.3 ppm (maximum)
16.	Oxygen absorbed	3 ppm (maximum)
17.	pH value	6.5 to 8.5
18.	Phenolic compounds	0.001 ppm (maximum) in terms of phenol
19.	Residual chlorine	0.05 to 0.2 ppm
20.	Sulphate	250 ppm (maximum)
21.	Total solids	500 to 1000 ppm. Preferable: below 500 ppm.

1.3.5.3 Biological Characteristics

1.	Total count	100 per 1 cc (maximum)
2.	Coliform index	3 to 10 (Preferable: Less than 3)
3.	M.P.N	1 in 100 ml

1.3.6. Standards laid down by BIS.I for drinking water

Different standards are followed by different water works, municipalities, corporations and public health departments for drinking water as presented by the Bureau of Indian Standards (BIS).

The IS10500-2012 (BIS) has recommended the following standards for drinking water.

S.No	Characteristic	Requirement (Acceptable Limit)
1	Colour, Hazen units, <i>Max</i>	5
2	Odour	Agreeable
3	pH value	6.5 to 8.5
4	Taste	Agreeable
5	Turbidity, NTU, <i>Max</i>	1
6	Total dissolved solids, mg/l, <i>Max</i>	500 or 500 ppm
7	Calcium (as Ca), mg/l, <i>Max</i>	75 or 75 ppm
8	Chloride (as Cl), mg/l, <i>Max</i>	250 or 250 ppm
9	Copper (as Cu), mg/l, <i>Max</i>	0.05 or 0.05 ppm
10	Fluoride (as F), mg/l, <i>Max</i>	1.0 or 1 ppm
11	Free residual chlorine, mg/l, <i>Min</i>	0.2 or 0.2 ppm
12	Iron (as Fe), mg/l, <i>Max</i>	0.3 or 0.3 ppm
13	Manganese (as Mn), mg/l, <i>Max</i>	0.1 or 0.1 ppm
14	Mineral oil, mg/l, <i>Max</i>	0.5 or 0.5 ppm
15	Nitrate (as NO ₃), mg/l, <i>Max</i>	45 or 45 ppm
16	Phenolic compounds (as C ₆ H ₅ OH), mg/l, <i>Max</i>	0.001 or 0.001 ppm
17	Sulphate (as SO ₄), mg/l, <i>Max</i>	200 or 200 ppm
18	Total alkalinity as calcium carbonate, mg/l, <i>Max</i>	200 or 200 ppm
19	Total hardness (as CaCO ₃), mg/l, <i>Max</i>	200 or 200 ppm
20	Zinc (as Zn), mg/l, <i>Max</i>	5 or 5 ppm
21	<i>All water intended for drinking:</i> a) <i>E.coli</i> or thermotolerant coliform bacteria ^{2), 3)}	Shall not be detectable in any 100 ml sample
22	<i>Treated water entering the distribution system:</i> a) <i>E.coli</i> or thermotolerant coliform bacteria ²⁾ b) Total coliform bacteria	Shall not be detectable in any 100 ml sample
23	<i>Treated water in the distribution system</i> a) <i>E.coli</i> or thermotolerant coliform bacteria b) Total coliform bacteria	Shall not be detectable in any 100 ml sample

Review Questions
PART – A (Two Marks)

1. What is demand?
2. What is per capita demand?
3. What are the sources of water?
4. What are the surface sources of water?
5. Name any two surface sources of water.
6. Mention the sub surface sources of water.
7. What is meant by variation in the rate of demand?
8. Mention the objectives of public water supply system. (Oct'2017)
9. Define intake.
10. What are the types of intakes?
11. What is canal intake?
12. What is reservoir intake?
13. What is river intake?
14. What is a pump?
15. What are the types of pumps?
16. What are the types of displacement pumps?
17. Define pipe corrosion.
18. What are the types of conduits used to convey water?
19. Differentiate cast-iron and galvanized iron pipe.
20. Mention the methods for prevention of pipe corrosion.
21. Name any two materials which are used as pipe.
22. What are the impurities present in water?
23. How will you measure colour in water?
24. Define hardness.
25. What is the limit of nitrite and nitrate in water?
26. Define pH.
27. What is the pH of pure water? Mention its unit.
28. What are the bacteriological tests conducted in pure water?
29. What are the physical characteristics of water?

30. Name the common water borne diseases.
31. What are the causes of water borne diseases?
32. List various physical impurities present in water.
33. What are the tests conducted to determine the impurities present in water?
34. List out the physical test on water.
35. Mention any four types of pipes used in the conveyance of water.
36. Write down the Indian standard for the following impurities in drinking water
 - (i) Fluoride
 - (ii) Chloride
 - (iii) Lead
 - (iv) Mercury

PART – B (Three Marks)

1. Write any three points on the need for protected water supply.
2. What are the objectives of public water supply system?
3. What are the types of demand?
4. What are the factors that affect per capita demand?
5. Describe an infiltration gallery with a suitable sketch. (Oct'2017)
6. What are the various methods of forecasting future population?
7. What are the factors to be considered while selecting site for a reservoir?
8. What are springs? What are its types?
9. What are the necessities of pumps?
10. What are the factors that govern the choice of a pump?
11. What are the components of centrifugal pump?
12. Mention any two advantages and disadvantages of centrifugal pump.
13. What are the effects of corrosion in pipe?
14. Define the term pipe corrosion and explain any two preventive methods. (Oct'2017)
15. What are the various types of pipe joint?
16. Explain collar joint for AC pipes.
17. Define turbidity. How will you measure turbidity?
18. Differentiate permanent and temporary hardness.
19. Give the permissible limits of the following in water.

- a. Total solids b. Chlorides c. Lead d. Dissolved oxygen e. Hardness
20. List various chemical impurities present in water.
21. List out the chemical tests on water.

PART – C (Ten Marks)

1. What are the objectives of public water supply scheme?
2. Explain the river intake and canal intake with suitable sketches.(Oct'2017)
3. Write in detail about types of demand.
4. Describe any three methods of prediction of population.
5. Briefly explain the factors that affect per capita demand.
6. Explain canal intake and reservoir intake with neat sketches.
7. Explain with neat sketch of river intake.
8. Give merits and demerits of any three pipe materials used in water supply system.
9. What is corrosion? What are the effects of pipe corrosion?
10. Explain the various prevention methods of pipe corrosion.
11. Enumerate any three chemical tests which are carried out for the analysis of water.
12. Explain briefly about water borne diseases.
13. Explain the various impurities in water.
14. What are the various impurities in water? How do they get into water?
15. Explain in detail how bacteriological test is conducted on water samples.
16. Explain the bacteriological test for the presence of E coli form group of bacteria.
17. Explain the different bacteriological tests to test the suitability of drinking water. OCT-17
18. The census data of a town is presented below. Determine the population of town in 2010 and 2020 by applying the incremental increase method and geometrical increase method.

Year	1970	1980	1990	2000
Population	15000	26000	39000	54300

19. Estimate the population in 2011 by arithmetical method, geometrical method, incremental increase method from the following data.

Year	1941	1951	1961	1971	1981	1991	2001
Population	12000	16500	26000	41500	57000	68500	75000

UNIT – II

2.1 TREATMENT OF WATER

(2.1: Objectives of water treatment - flow diagram of treatment plants – sedimentation – purpose - types of sedimentation - coagulation - coagulants and their choice - types of sedimentation tanks – filtration - theory of filtration - types and description of filters - disinfection of water – methods - water softening – miscellaneous water treatment (names only) - mineral water – requirements - R.O process)

2.1.1 GENERAL:

Water available in any form in earth contains various types of impurities. Hence to make water as potable, it requires different types of water treatment based on the impurities present in it.

2.1.2 OBJECTIVES OF WATER TREATMENT

The following are the objectives of water treatment.

1. Removal of colour
2. Removal of bad odour
3. Providing taste to water
4. Removal of dissolved gases
5. Removal of all kinds of physical, chemical and bacteriological impurities and make water fit for all types of consumption.

2.1.3 Sedimentation:

It is the initial stage of treatment of water. The heavier and lighter organic and inorganic impurities will be removed by the process of sedimentation.

2.1.3.1 Purpose of sedimentation:

The presence of organic and inorganic impurities into water at undesirable limit may cause serious ill effects to the living beings while consumption. It may also affect the various industrial products including food processing. It makes turbidity to water and cause corrosion while flowing into pipes. Hence, it is essentially required to remove inorganic impurities having specific gravity of about 1.04.

2.1.3.2 Types of Sedimentation:

The following are the types of sedimentation.

1. Plain sedimentation
2. Coagulation or chemically aided sedimentation

1. Plain sedimentation:

It is the process of removal of impurities from water by reducing its velocity thus called detention time. The time taken by the water particles to move from inlet to outlet of sedimentation tank is called detention time. During this detention time, the impurities present in water are settled at the bottom of tank. This phenomenon of settlement is known as hydraulic subsidence.

2. Coagulation or chemically aided sedimentation of water:

The source of water for most of public water supply project is the surface water. The surface water mostly contains turbid and suspended impurities. It also possesses colour due to the presence of colloidal matter and dissolved organic matters. The turbidity is mainly due to the presence of very fine particles of clay, silt and organic matters. All these impurities are in a finely divided state and it is too difficult to remove from water through sedimentation. Hence extra treatment called coagulation sedimentation is required.

2.1.4 Coagulation:

It is the process of adding coagulants or chemicals into the impure water. Thus the adding of coagulant into water converts smaller size particles into bigger size and cause the settle of impure particles at the bottom of water.

2.1.4.1 Types of Coagulants:

The following usual coagulants are adopted for coagulation

1. Aluminium sulphate or alum
2. Chlorinated copperas
3. Ferrous sulphate and lime
4. Magnesium carbonate
5. Polyelectrolytes
6. Sodium aluminate

2.1.4.2 Choice of Type of Coagulant:

1. It should be cheaper and most affective.
2. It is to be simple in working
3. It should produce clear water
4. It should not harm during working
5. It does not require skilled labour

2.1.5: Types of sedimentation tank:

Usually the sedimentation tanks are classified based on its nature of working and its shape in construction. Depending upon the nature of working, the following are the two types.

1. Fill and draw type tank
2. Continuous flow type tank.

1. Fill and draw type tank:

The working of this type of tank is very simple. The water is filled in the tank and it is then allowed to take rest for certain time. During the period of rest, the heavier particles settle at the

bottom of the tank and the lighter particles float at the edges of the tank. The clear water is then taken and the tank is cleaned of silt and floating impurities and filled again.

The usual period of rest to cause settlement of particle is about 24 hours or so. Considering the time required for filling and emptying and cleaning of tank, a time of 30 to 36 hours is required to put the tank again in use. Hence, the additional one tank is used as stand by.

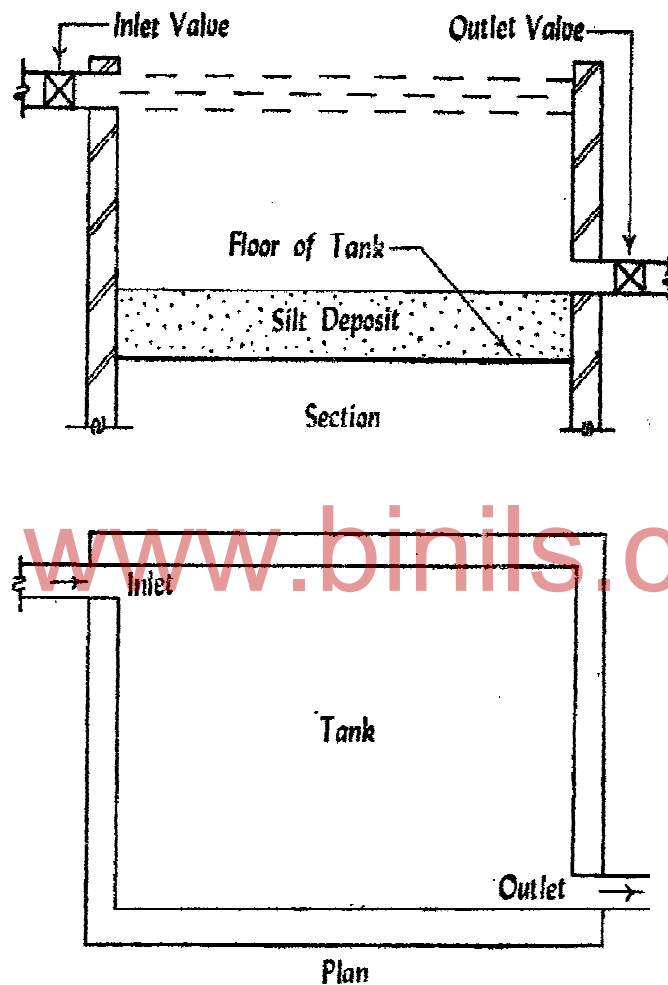

Fig – 2.1 - Fill and Draw type Sedimentation tank

2. Continuous flow type sedimentation tank:

In this type of tank, the velocity of flow of water is considerably reduced. A huge amount of suspended impurities from water can easily be removed. This is the principle on which continuous flow type of sedimentation tank is working.

In this tank, the water is allowed to enter in one end and travel towards the outlet at the other end. During the travelling of water into the tank, the velocity of water is considerably reduced by

means of baffle walls. The velocity of water is so adjusted that the time taken by a particle of water to move from one end to the other end is slightly more than that required for the settlement of suspended impurities in water. The entry of raw water from one end and exit of clear water from the other end are continuous. During this process, the silt deposited at the bottom of tank and the floating matters at the top are suitably cleaned.

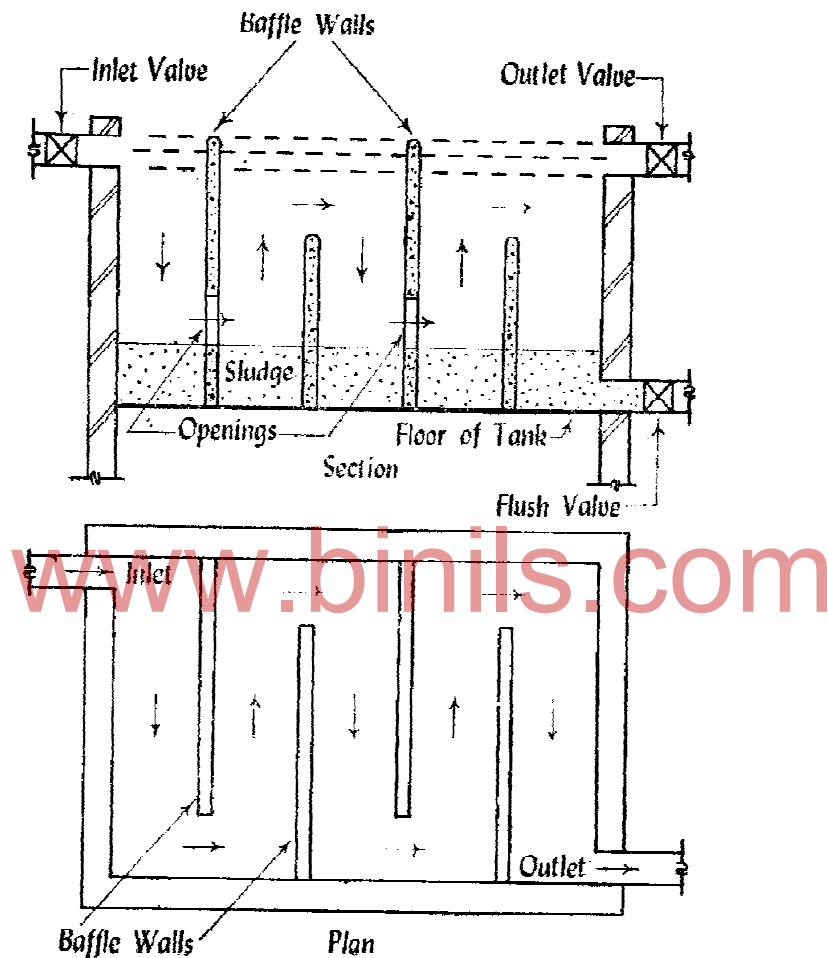

Fig 1.2 – Continuous Flow Sedimentation tank

2.1.6 Filtration of water:

It means allowing of water to pass through a thick layer of sand. During this process the following effects occur on water.

1. The suspended and colloidal impurities which are present in water in finely divided state are removed.
2. The chemical characters are considerably reduced
3. The presence of bacteria is considerably reduced.

2.1.6.1 Theory of filtration:

The following are the theories in which the filtration of water is processed

1. Mechanical straining
2. Sedimentation
3. Biological metabolism
4. Electrolytic charges.

1. Mechanical Straining

The suspended particles which are unable to pass through the voids of sand grains are arrested and removed by the action of mechanical straining.

2. Sedimentation:

The voids between sand grains of filter act more or less like small sedimentation tanks. The particles of impurities arrested in these voids, adhere to particles of sand grains mainly due to the following two reasons:

- i) Due to the presence of gelatinous film or coating developed on sand grains by previously caught bacteria and colloidal matter
- ii) Due to physical attraction between the two particles of matter.
- iii) Thus suspended impurities are removed by filter by the action of sedimentation.

3. Biological metabolism:

The growth and life process of the living cells is known as biological metabolism and the action of filter is explained on the basis of biological metabolism. When bacteria are caught in the voids of sand grains, a zoological jelly or film is formed around the sand grains. The bacteria feed on the organic impurities contained in water. They convert such impurities into harmless compounds by the complex biochemical reactions.

4. Electrolytic changes:

The action of filter is also explained by the ionic theory. It states that when two substances with opposite electric charges are brought into contact with each other, the electric charges are neutralized and in doing so, new chemical substances are formed. It is observed that some of the sand grains of filter are charged with electricity of some polarity. Hence, when particles of suspended and dissolved matter containing electricity of opposite polarity come into contact with such sand grains, they neutralize each other and it ultimately results in the alteration of chemical characters of water. After some interval of time, the electrical power of sand grain gets exhausted. At that time, it becomes necessary to clean the filter and restore it with this property.

2.1.6.2 Types of Filters

Broadly, the filters are grouped as Gravity type filter and Pressure filter. Further, the Gravity filters are sub divided into Slow filters and Rapid filters. Based on the filter media used, it is generally classified as

- i) Slow sand filter
- ii) Rapid sand filter
- iii) Pressure filter

www.binils.com

2.1.6.3 Description of Filters:

i) Slow sand filter

a) Construction: The slow sand filter consists of the following components

- 1) Enclosure tank
- 2) Under drainage system
- 3) Base material (Gravels)
- 4) Filter media (sand)
- 5) Appurtenances

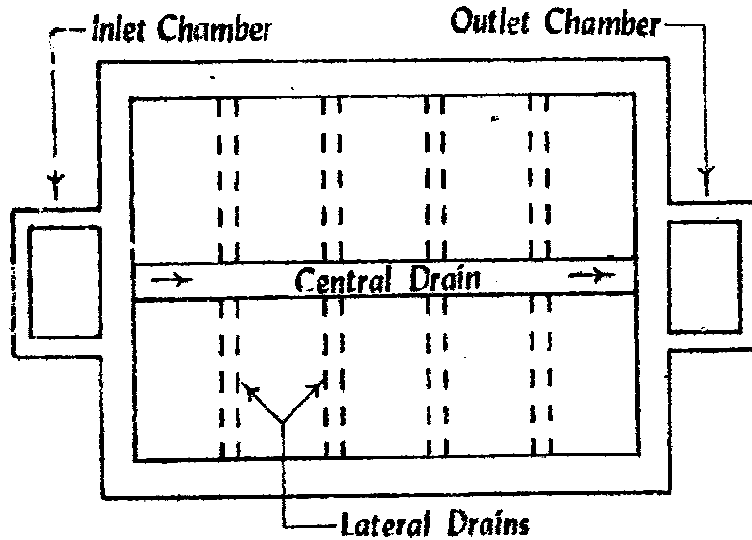

Fig. 2.3(a) - Plan of slow sand filter

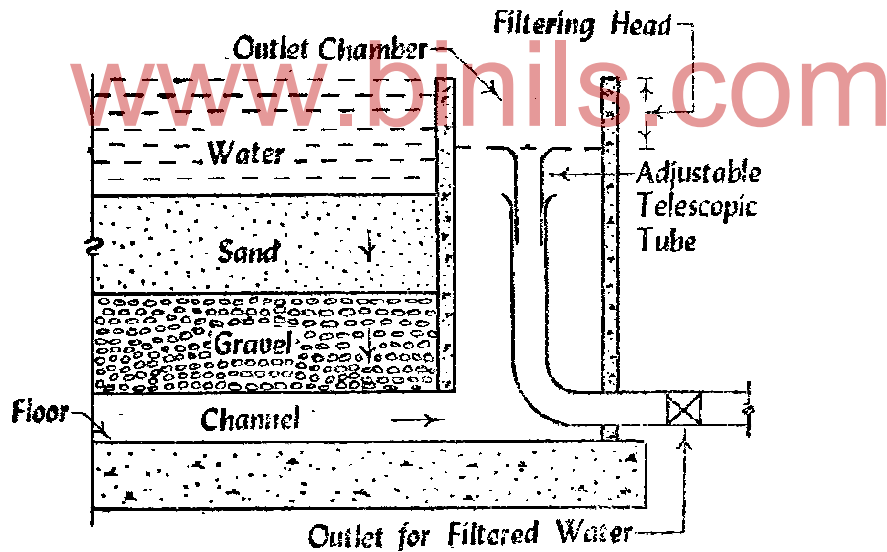

Fig. 2.3(b) – Cross – section through outlet chamber

1. Enclosure tank:

A water tight tank is constructed in any type of masonry. The sides and floor are provided with water proof material. The bed is provided with a slope ranges between 1 in 100 and 1 in 200 towards the central drain. The depth tank is about 2.50 m to 3.50 m. The surface area may vary from 30 m² to 2000 m²

2. Under drainage system:

The under drainage system consists of a central drain and lateral drains. The lateral drains are placed at a distance of about 2.50 m to 3.50 m and they are stopped at a distance of about 50 cm to 80 cm from the walls of the tank. The drains may be of pipes which are laid with open joints or they may consist of patented drain devices.

3. Base material :

Gravel is used as the base material and placed on the top of the under drainage system. Its depth varies from 300 mm to 750 mm. It is usually graded and laid in layers of 150 mm. The top most layer should be of small size gravel and the lowest layer should be of bigger size gravel.

The following are the typical sections if base material of size of gravel

Top most layer	–	150 mm depth – 3 mm to 6 mm
Intermediate layers	–	i) 150 mm depth – 6 mm to 20 mm ii) 150 mm depth – 20 mm to 40 mm
Bottom layer	–	150 mm depth – size 20 mm to 40 mm
Total depth	–	600 mm

www.binils.com

4. Filter media of sand:

Sand is used as filter media and placed above the base material gravel. The depth of filter media varies from 600 mm to 900 mm and is placed in number of layers of 150 mm thickness. The effective size of sand used as filter media ranges from 0.20 mm to 0.30 mm and the uniformity coefficient of sand is about 2 to 3. Finer is the sand, better will be the efficiency in removal of bacteria.

5. Appurtenances:

The following appurtenances are usually employed for the effective working slow sand filter.

1. Vertical air pipe
2. Adjustable telescopic tube

b) Working of slow sand filter:

The water is allowed to enter the filter through the inlet chamber. It descends through the filter media and gets purified. It is then collected in the outlet chamber and taken to clear water storage tanks. It is to be noted that water should not be treated with coagulation in sedimentation tanks. This is due to the fact that dirty skin formed by floc and carried to the filter considerably affects the economical working of the filter.

The depth of water on filter should be more or equal to the height of filter media of sand. The slow sand filters are usually worked for a maximum filtration head of 750 mm or so. But for the safety point, the filter head of water should be multiplied by a coefficient factor of 0.67 to 0.80. The rate of filtration of slow sand filter varies from 100 lit to 200 litres per m² of filter area.

c) Cleaning of slow sand filter:

For the purpose of cleaning, the top layer of sand is scraped and removed to a depth of about 15mm to 25mm. The water is then admitted to the filter. But the purified water is not taken into use until the formation of film around sand grains occurs. This may require a period of about one or two days.

When a cleaning of filter had been done for a number of times, the effective depth of filter media of sand is reduced. In order to maintain the efficiency of filter, a fresh layer of 150 mm depth of graded sand is then added to the filter. At places, where acute shortage of filtering sand, the scraped sand obtained during cleaning operation is washed and stored for future replacement.

The interval between two successive cleanings depends mainly on the nature of impurities present in water to be treated and the size of filtering sand. It usually varies from 1 to 3 months.

d) Efficiency of slow sand filter:

- a. It is high efficient in removal of bacteria. It removes bacteria up to 99.90 percentage.
- b. It is less efficient in removal of colour from raw water.
- c. It removes turbidity up to the extent of 50 ppm.

ii) Rapid sand Filter

a) **Construction:** The rapid sand filter consists of the following components.

1. Enclosure tank
2. Under drainage system
3. Base material of gravel
4. Filter media of sand
5. Appurtenances.

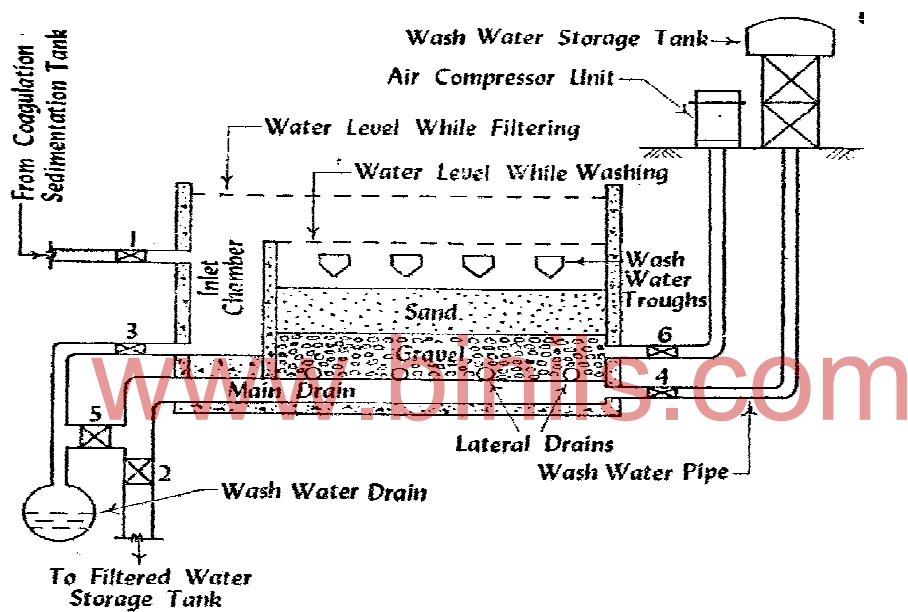

Fig 2.4(b) – Section of a typical rapid sand filter (gravity type)

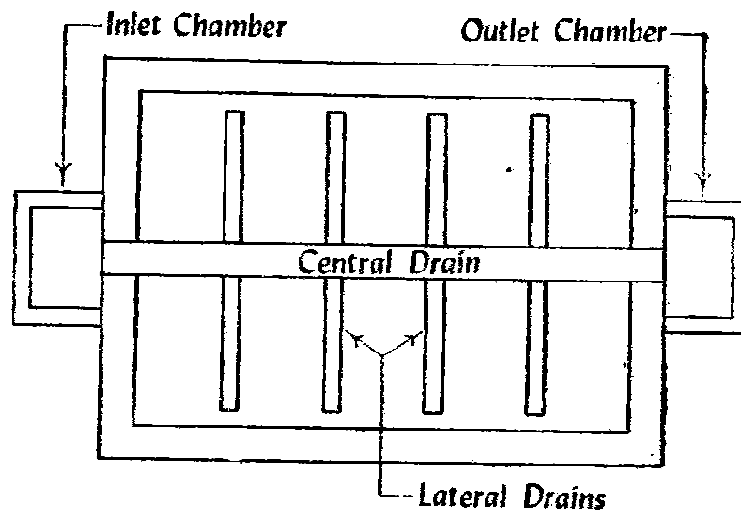

Fig 2.4(a) – Plan of a typical rapid sand filter (gravity type)

1) **Enclosure Tank:**

A water tight tank is constructed in any kind of masonry. The sides and floors are provided with water proofing coating. The depth of the tank is about 2.50 m to 3.50 m. The surface area varies from 10 m² to 50 m². The units are arranged in series.

2) **Under drainage system:**

The under drainage system consists of pipe net works in the two forms.

- i) Perforated pipe system
- ii) Pipes and strainer system

i) Perforated pipe system:

In this system, there is a central drain or manifold and to this manifold various lateral drains are attached. The drains are usually made of cast iron. The lateral drains are placed at a distance of about 150 mm to 300 mm. The lateral drains are provided at the bottom side and such holes make an angle of 30 degree with the vertical. The diameter of holes is about 10 mm and they are sometimes staggered on either side instead of being continuous. The centre to centre distance of the hole is about 75 mm to 200 mm. In order to prevent rusting of holes surface, brass bushings are sometimes inserted in the holes. For the support of lateral drain, concrete blocks of thickness about 40 mm to 50 mm are placed on the floor of filter. The perforated system is economical and simple in operation. It however requires about 700 litres of water per minute per m² of filter area for washing purpose. This is known as **high velocity wash**.

ii) Pipe and strainer system:

In this system, there is a central drain or manifold with lateral drains attached on either side. In this system, strainers are placed on lateral drains. Instead of drilling holes. A strainer is a small pipe of brass. It is closed at the top and contains holes on its surface. The strainers are either fixed or screwed on the top of lateral-drains. The lateral drains as well as strainers are generally placed at a distance of 150 mm.

When the pipe and strainer system is adopted, air is used for the purpose of washing the filter. This results in saving wash water. It requires about 250 litres of water per minute per m² area of filter area for washing purpose. This is known as **low velocity wash**.

3) Base Material:

Gravel is used as base material of the drainage system. The gravel used as base material should be clean and free from clay, dust, silt and vegetable matter. The gravel particles should be durable, hard round and strong. Its depth varies from 450 mm to 600 mm. It is usually graded and laid in layers of 150 mm depth. The top most layer should be of small size gravel and the lowest layer should be of big size gravel. The following are the typical section of base material.

Top most layer	–	150 mm depth – size 3 mm to 6 mm
Top most layer	–	150 mm depth – size 3 mm to 6 mm
Intermediate layers	–	i) 150 mm depth – size 6 mm to 12 mm ii) 150 mm depth – size 12 mm to 20 mm
Bottom most layer	–	150 mm depth – size 20 mm to 40 mm
Total	–	600 mm depth

4) Filter media of sand:

A layer of sand is placed above the gravel. The depth of filter media varies from 600 mm to 900 mm. The coarse sand is used as filter media. The effective size of sand varies from 0.35 mm to 0.60 mm and the uniformity coefficient of sand is between 1.20 & 1.70. Thus, the space of voids between sand particles is increased and it results in the increased rate of filtration.

5) Appurtenances:

The following essential special appurtenances are required for the efficient functioning of rapid sand filter.

1. Air compressor
2. Wash water trough
3. Rate control
4. Wash water over head tank.

b) Working of Rapid sand filter:

The water from sedimentation or coagulation sedimentation tank is permitted to enter over the filter bed through inlet and allows to percolate in to the bed of filter. Then the water is purified and stored in the storage tank. Several rate controllers are used to make effective functioning of filter. The rate of filtration of normal rapid sand filter is about 3000 to 6000 litres per hour per m² of surface area.

c. Cleaning of rapid sand filter

Back washing process of cleaning is adopted in rapid sand filter with the help of air compressor and wash water over head tank. Simultaneously air from compressor and water from over head tank is injected through under drainage system. The injected water cleans the voids of gravel and sand and the waste water is collected. Proper operation of rate controller makes the cleaning of filter for its reuse.

d. Efficiency of Rapid Sand Filter:

The following are the efficiency of rapid sand filter.

- i) It is less efficient in removal of bacteria. It removes only about 80 to 90 percentage of bacteria present in water.
- ii) It is high efficient in removal of colour. It brings down the colour below 10 cobalt scale.
- iii) It removes turbidity to the extent of 40 ppm. If coagulation treatment is given, it brings down turbidity to the permissible limits.

iii) Pressure Filter:

- a) **Construction:** The pressure filters are closed steel cylinder either riveted or welded. They may be horizontal or vertical type. The diameter of pressure filter varies from 1.50 m to 3 m and its height varies from 3.50 m to 8 m. The man holes are provided at the top for inspection.
- b) **Working of pressure filter:** The water mixed with coagulation is directly admitted to the pressure filter. Thus the coagulation process takes place inside the pressure filter and the water gets purified. The rate of filtration is about 6000 to 15000 litres per hour per m² of surface area. It is less efficient than other filters in the removal of impurities.

2.1.6.4 Comparisons between slow and filter and rapid sand filter (Difference between two types of filters)

No	Item	Slow and filters	Rapid sand filters (Gravity type)
1.	Base material of gravel	Varies from 3 to 65 mm in size and 300 to 750 cm in depth	Varies from 3 to 40 mm in size and 600 to 900 cm in depth
2.	Coagulation	Not required	Essential
3	Compactness	Requires large area for its installation	Requires small area for its installation
4	Construction	Simple	Complicated as under drainage system is to be properly designed and constructed.
5	Economy	High initial cost of both, land and material	Cheap and quite economical
6	Efficiency	Very efficient in the removal of bacteria but less efficient in the removal of colour and turbidity.	Less efficient in the removal of bacteria but more efficient in the removal of colour and turbidity
7	Filter media of sand	Effective size varies from 0.20 to 0.30 mm and uniformity coefficient is about 2 to 3.	Effective size varies from 0.35 to 0.60 mm and uniformity coefficient is about 1.20 to 1.70.
8	Flexibility	Not flexible for meeting variations in demand	Quite flexible for reasonable fluctuation in demand.
9	Loss of head	150 mm to 750 mm	3 m to 3.50 m
10	Method of cleaning	Scraping of top layer of 15 mm to 25 mm thickness. Long and laborious method.	Agitation and backwashing with or without the help of compressed air. Short and speedy method.
11	Period of cleaning	1 to 3 months	2 to 3 days
12	Rate of filtration	100 to 200 litres per hour per m ² of filter area.	3000 to 6000 litres per hour per m ² of filter area
13	Skilled supervision	Not essential	Essential
14	Suitability	The filter can be constructed of local labour and material. It is suitable for small towns and villages where land is cheaply available	It is suitable for big cities where land cost is high and variation in demand of water is considerable

2.1.7 Disinfection of water:

The following impurities are still found in the water which leaves from filter

- 1) Bacteria
- 2) Dissolved inorganic salts
- 3) Colour, odour and taste
- 4) Iron and manganese

The removal of bacteria from water is called disinfection of water. Minor and Major methods of disinfection are employed for disinfection.

2.1.7.1 Minor methods of disinfection

1. Boiling method
2. Excess lime treatment
3. Iodine and bromine treatment
4. Ozone treatment
5. Potassium permanganate treatment
6. Silver treatment
7. Ultra violet ray treatment

1. **Boiling method:**

When water is boiled above a certain temperature, bacteria are removed. The boiling of water is the most effective treatment method of disinfection. But boiling of water on large scale is impracticable. However in case of epidemic, the consumer may be advised to boil the water before use.

2. **Excess Lime treatment:**

The treatment of lime is given to water for the removal of dissolved salts. But if excess lime is added to water, it will also work in addition as a disinfecting material.

3. **Iodine and Bromine treatment:**

When water is treated with iodine or bromine, it is disinfected. The dosage of iodine or bromine is about 8 ppm and the contact period with water is about 5 minutes.

4. **Ozone treatment:**

The atmospheric oxygen is in molecular form containing two atoms of oxygen. But when a high tension electric current is passed through a stream of air in a closed chamber, triatomic molecules of oxygen are formed as shown by the following equation.

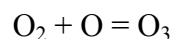

Such oxygen (O₃) is called ozone. The third atom is loosely bound and the ozone easily breaks down into oxygen and releases nascent oxygen which is very powerful in killing bacteria. The ozone also unites with organic matter and it is thus effective in the removal of organic matter. The advantage of ozone treatment is that ozone is unstable and it does not remain in the water when it reaches the consumer. The dosage of ozone is about 2 to 3 ppm to obtain residual ozone of 0.10 ppm and the contact period is about 10 minutes.

5. Potassium Permanganate treatment

This disinfectant works as a powerful oxidising agent and found to be effective in killing cholera bacteria. However it is less effective for other water disease producing organisms. The use of this disinfectant is restricted to the disinfection of water of village wells and ponds and its dosage is about 2.1 ppm with contact period of about 3 to 4 hours.

6. Silver treatment:

The metallic silver is placed as filter media and water, while passing through such a filter absorbs some portion of silver which disinfects water. The dosage of silver varies from 0.05 to 1 ppm and the period of contact is about 15 minutes to 3 hours. It does not harm living organisms, but is a costlier treatment.

7. Ultra – Violet ray treatment:

The invisible light rays beyond the violet spectrum are very effective in killing all the types of bacteria. For generating these rays, the mercury is enclosed in one or more quartz bulbs and electric current is then passed through for effective disinfection. The water should be passed round the bulbs several times and the depth of water over the building should not exceed 10 cm or so. The water should be colourless and its turbidity should not be more than 15 ppm.

2.1.7.2 Major Disinfection:

The disinfectant widely adopted to remove bacteria is called major disinfection. Universally chlorine is mostly used as a disinfectant for this purpose.

2.1.7.3 Chlorination:

Adding of chlorine in to water for removal of bacteria is called chlorination. When Chlorine is added into water the following **action** takes place.



The hypochlorous acid (HOCL) and hypochlorite ions (OCL) are responsible for the removal of bacteria. The dosage of chlorine depends on the impurities present in water. It usually varies from 0.20 ppm to 1 ppm. The following are the forms or application of chlorine.

- i) Bleaching powder
- ii) Chloramines
- iii) Free chlorine gas

2.1.7.4. Methods of chlorination:

The following methods are adopted in the use of chlorine for chlorination.

1. Plain chlorination
2. Pre- chlorination
3. Post – chlorination
4. Double chlorination
5. Break point chlorination
6. Super chlorination
7. De chlorination

1. Plain chlorination:

The usage of chlorine alone for treatment of water is called plain chlorination. The chlorine is added to raw water to control the growth of algae and to remove bacteria. The quantity of chlorine to be added in raw water is about 0.50 ppm or more.

2. Pre- chlorination:

When chlorine is added to raw water before any treatment, it is known as pre-chlorination. The dosage should be so adjusted that about 0.10 to 0.50 ppm of chlorine comes to the filter plant.

3. Post – chlorination:

When chlorine is added in to the purified water by the completion of all treatments, then it is called post – chlorination: The dosage of chlorine is so adjusted that 0.10 ppm to 0.20 ppm appears in water at the point of distribution system.

4. Double chlorination:

The chlorine added to raw water at more than one point is known is Double chlorination. When raw water is highly contaminated and contains large amount of bacteria, it is necessary to adopt double chlorination.

5. Break point chlorination:

The chlorine is added into water for the purpose of treatment. If the water is pure and if any amount of chlorine is added in such water, it appears as residual chlorine. But for water containing highly organic matters, the chlorine performs the following functions.

- i. Removal of bacteria
- ii. Oxidise the organic matter present in water.

When chlorine is added in water, it starts to remove the bacteria first then it starts to accumulate certain quantity and then it starts to oxidise the organic matters. The point where the chlorine starts to change the process of removal of bacteria to oxidization of the organic matters is called break point chlorination.

6. Super chlorination:

The application of chlorine beyond the stage of break point is known as super chlorination. The residual chlorine content after the break point may be 0.50 to 2 ppm.

7. Dechlorination:

The removal of excess chlorine from water is known as dechlorination.

2.1.8 Water softening:

Removal of all kinds of hardness from water is called water softening

2.1.8.1. Purpose: The following are the purposes for the removal of hardness from water.

1. It affects dyeing industries
2. It causes corrosion
3. It affects laundry works by consuming more soap
4. It makes food tasteless tough or rubbery
5. It provides scales on boilers

2.1.8.2 Hardness of water:

The presence of bicarbonates, chlorides, sulphates and nitrates along with calcium and magnesium is called hardness of water. The following are the types of hardness

- i) Temporary Hardness
- ii) Permanent Hardness

i) Temporary hardness:

The presence of bicarbonates of calcium and magnesium is called temporary hardness or Carbonate hardness. It can be removed by boiling of water or adding of lime into water.

ii) Permanent hardness:

The presence of chlorides, sulphates and nitrates of calcium and magnesium is called permanent hardness or non-carbonate hardness.

The following methods are usually employed for the removal of such hardness.

- i) Lime – soda process
- ii) Zeolite process
- iii) Demineralisation process

2.1.9 Miscellaneous water treatments:

The following impurities are removed by this method.

1. Colour Taste and Odour
2. Iron and manganese
3. Fluoridation

2.1.9.1 Methods of miscellaneous treatment

1. Aeration
2. Activate Carbon Treatment
3. Copper Sulphate Treatment
4. Removal of Iron and Manganese
5. Fluoridation and De fluoridation

2.1.10 Mineral water:

It is the water that comes out of the ground naturally and considered healthy to drink. This water contains required salts and gases and usually has medicinal properties.

2.1.10.1 Requirement of Mineral Water:

1. It should be free from impurities
2. It should contain sufficient salts
3. It should contain necessary gases
4. It should be pleasant and palatable
5. It should be free from bad odour
6. It should give acceptable taste

2.1.11 Reverse Osmosis process:

R.O. Process is a process in which dissolved inorganic salts are removed from a solution such as water. It works by using high pressure pump to increase the pressure on the salt side of R.O and force the water across the semi-permeable RO membrane leaving almost all the dissolved salts

behind in the reject stream. R.O can also act as an ultra filter removing particles such as some micro organisms that may be too large to pass through the pores of the membrane. The common membrane material includes polyamide thin film composites (TFC), cellulose acetate (CA) and cellulose triacetate. (CTA)

2.1.12 Flow diagram Water Treatment Plant

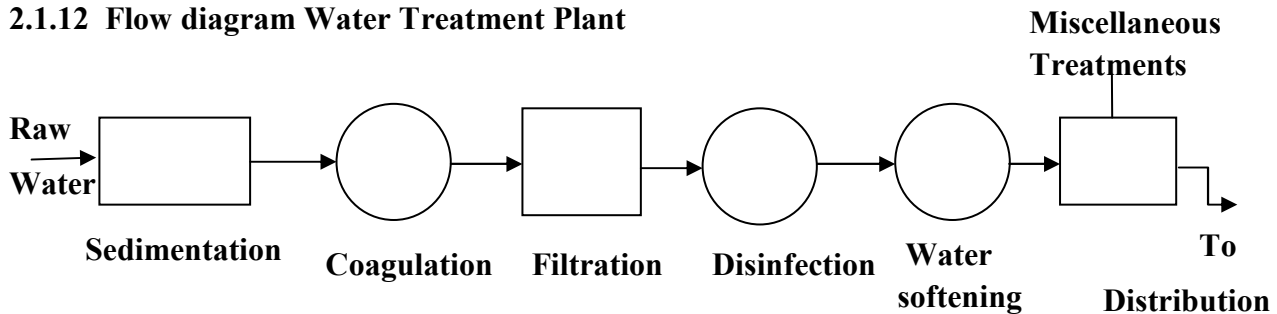

(Fig: 2.5)

Sedimentation:

It is the initial stage of water treatment. The heavier and lighter organic and inorganic impurities will be removed by detention time in sedimentation tank.

Coagulation

It is the process of adding coagulants into water. The impurities having specific weight lesser than water is removed by this process.

Filtration:

The physical, chemical and bacteriological impurities are removed by allowing the water to pass through thick layer of sand.

Disinfection:

It is the process of removal of bacteria from water by adding disinfectant like chlorine etc...

Water softening:

It is the process of removal of hardness from water

Miscellaneous treatment:

It is the process of removal of colour, taste and odour, Iron and Manganese, Fluorides and other substances from water.

Distribution:

Clear, safe and sufficient quantity of water is supplied to the consumers.

2.2 DISTRIBUTION SYSTEM

(2.2 : Distribution system - methods of distribution – gravity system, pumping system, combined system -systems of water supply - continuous and intermittent supply of water - layouts of distribution - dead end , grid iron, radial and circular systems - service reservoirs – types)

2.2.1 Meaning:

It is the system that supplies safe and wholesome water with adequate pressure and required quantity to all the area where the consumers live.

2.2.2. Methods of Distribution:

Mostly, the following methods are adopted for distribution of water

1. Gravity system
2. Pumping system
3. Combined gravity and pumping system

1. Gravity system:

In this method, the source of water supply is located at the higher elevation and the distribution area is situated at the lower elevation. The water is conveyed from higher elevation of source to lower elevation of distribution area through pipes or by any other means under gravity only. The gravity system is more reliable method of system.

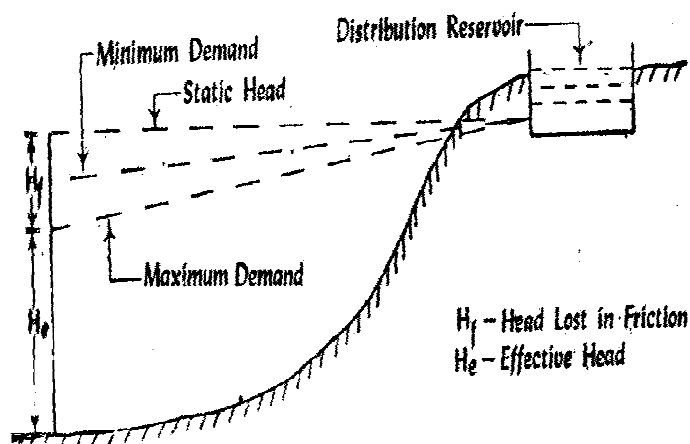

Fig 2.6 – Gravity System

2. Pumping system:

In this system, the source of water supply is located at the lower elevation and the distribution area is situated at the higher elevation. The water from lower elevation is directly pumped in to the mains of distribution system. This system causes many inconveniences due to the following reasons.

- i. In case of power failure, the entire water distribution system is affected
- ii. It requires constant attendance
- iii. It requires skilled labour for its effective functioning.

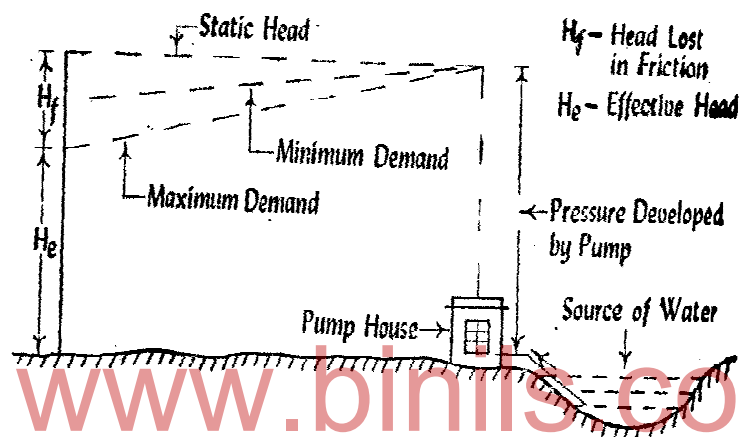

Fig 2.7 –Pumping Systems

3. Combined Gravity and Pumping System:

This method is adopted in the level ground, where the distribution area is situated. The water from lower elevation source is pumped and stored in the elevated reservoir placed in the distribution system. For that, the water is conveyed into the distribution system under the force of gravity. The excess water during low consumption remains in the elevated reservoir and is supplied during peak hours of consumption. This method is usually adopted due to the following advantages.

- i) In case of fire, motor pumps can be used to develop high pressure
- ii) This method is economical
- iii) The water can be supplied into the distribution system from elevated reservoir even during power failure or break down of pumps.

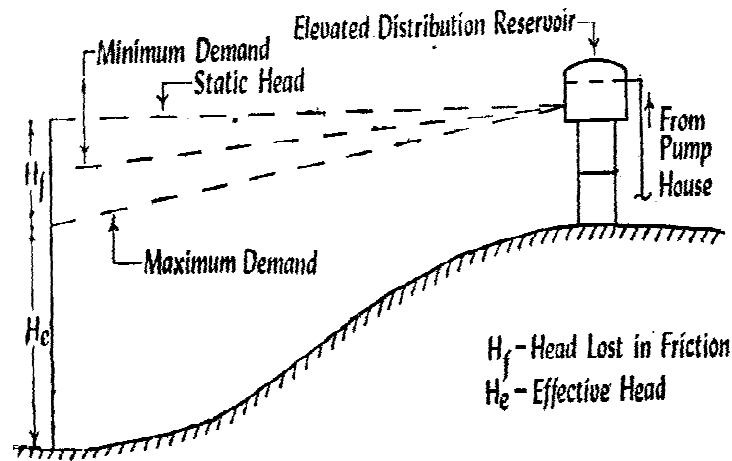

Fig 2.8 – Combined Gravity and Pumping Systems

2.2.3 Systems of Water:

The systems of water supply are discussed as below

1. Continuous system
2. Intermittent system

1. Continuous System:

In this system of water supply, the water is supplied to the consumers throughout 24 hours of a day. This system is most reliable and ideal system for the supply of water. But when this system is adopted, the following disadvantages may occur.

- i) During repair of distribution system, the entire water supply gets affected
- ii) Considerable wastage of water may occur due to the lack of sense of the consumers. This wastage may be avoided by fixing of meters in the water supply system and charging accordingly.

2. Intermittent System of Water Supply:

In this system of water supply, the water is supplied to the consumers during a certain fixed hours in the morning and the same time in the evening (or) any one session of a day. The timing of water supply is decided based on the availability, of water, seasons and its demand. This system is suitable for the following two conditions.

1. Available pressure is poor
2. Limited quality of water is available.

Advantages

1. Repairs will be carried out during non-supply period.
2. The available quantity of water is limited in the source, the demand of water will be satisfied.

Disadvantages of this system:

1. If fire occurs during non-supply period of water, it creates more difficulties.
2. Chances of pollution may occur in the stored water and thus lead to the wastage of water.
3. It requires greater size of mains.
4. It is possible to create partial vacuum during sudden stoppage of water.

2.2.4 Methods of layout of distribution system :

The following methods are usually employed in the distribution system.

- i) Dead end system
- ii) Grid – iron system
- iii) Circular system
- iv) Radial system

I. Dead end system:

This system consists of one supply main from which sub mains are taken. The sub mains are again divided into several branch lines from which service connections are given to the consumers. When this system is adopted, more number of dead ends may occur. The development of this system is as same as the growth of branches of tree. Hence this system is also called as tree system. This system is adopted in the areas where it expands irregularly and the pipes are laid without planning of future developments.

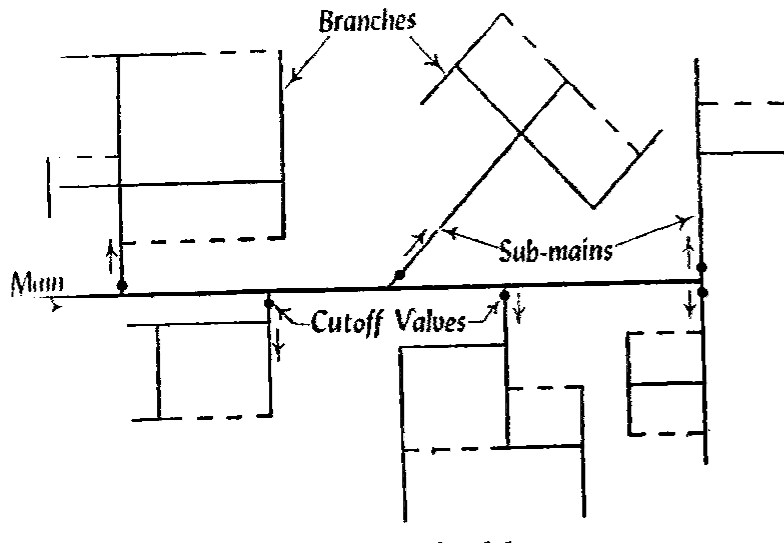

Fig 2.9 - Dead – end method of layout

Advantages:

- i) It is possible to work out the accurate discharge and pressure of water.
- ii) Minimum number of cut-off value is required.
- iii) It is cheap and economical
- iv) Laying of pipes are simple

Disadvantages:

- i) During repairs, vast distribution area gets affected.
- ii) More number of dead ends may freeze the circulation of water
- iii) Limited water will be available for fire fighting purposes.

II. Grid – iron method:

In this method the mains which are placed centrally is interconnected with sub mains and branches. This method is also called as interlaced or reticulations system. This system is most suitable for towns having well- planned roads and streets.

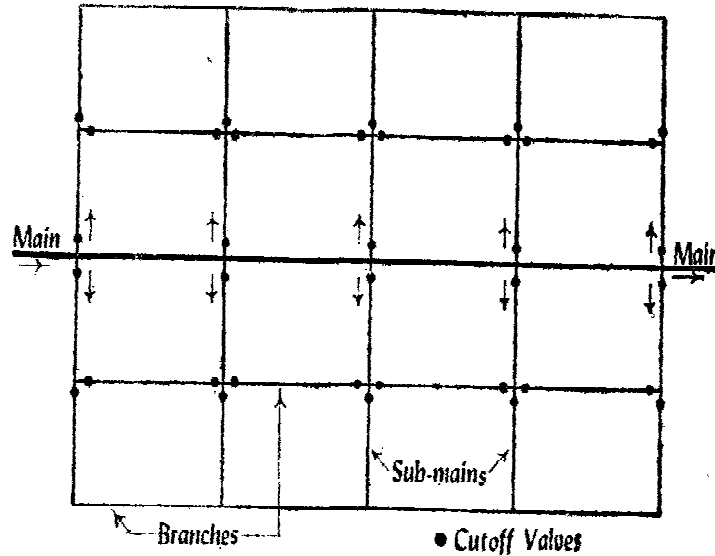

Fig 2.10 – Grid – iron method of layout

Advantages:

- i) During repairs, small portion of the distribution area will be affected
- ii) It ensures free circulation of water and thus reduces the possible pollution of stagnation
- iii) Plenty of water is available for fire fighting.
- iv) It provides minimum loss of head.

Disadvantages:

- i) The cost of laying of pipes is more
- ii) It requires longer length pipes
- iii) The procedure of design of size of pipes and pressure at various points is difficult
- iv) More number of valves are required in this system

III. Circular method:

In this method a ring of main pipes around the distribution area is provided. The distribution area is divided into rectangular or circular blocks and the water mains are laid on the periphery of these blocks. This system of layout is the most suitable for towns having well planned roads and streets. This system is also called as ring system.

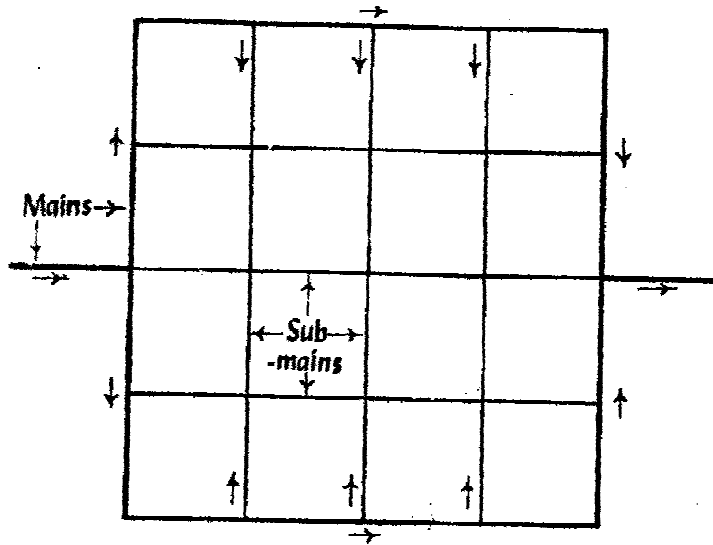

Fig 2.11 Circular Method of Layout

Advantages:

- i) During repairs, small portion of the distribution area will be affected
- ii) It ensures free circulation of water and thus reduces the possible pollution of stagnation
- iii) Plenty of water is available for fire fighting.
- iv) It provides minimum loss of head.

Disadvantages:

- i) The cost of laying of pipes is more
- ii) It requires longer length pipes
- iii) The procedure of design of size of pipes and pressure at various points is difficult
- iv) More number of valves are required in this system

IV. Radial method:

In this method, the water is taken from the mains, pumped and stored into the distribution reservoirs which are situated at centres of different zones. The water is supplied through radially laid pipes. This method is best suited for towns having roads laid out radially.

Advantages:

- i. It enables to provide quick service of water supply.
- ii. The design and size of pipes are simple
- iii. It ensures sufficient quantity of water and required pressure for fire fighting purposes

iv. It provides uninterrupted water supply at any time

Disadvantages:

- i. It involves more initial cost
- ii. It requires more number of cut-off valves.

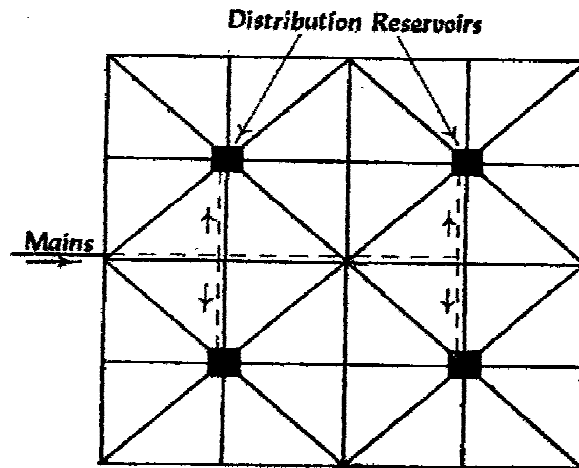

Fig 2.12 Radial method

2.2.5 Service Reservoirs:

In the distribution system, to store clear and treated water service reservoirs are provided. The service reservoirs are the enclosed structures or tanks which are constructed of brick masonry, cement concrete or stone masonry for the purpose of storing and serving the water to the consumers.

2.2.5.1 Purpose of Service Reservoir:

The following are the purposes served by the service reservoir

- i) It is used to store water and to be used for emergencies like repair of pumps, fires, failure of power etc., in spite of water supply
- ii) To maintain uniform pressure in the distribution system
- iii) To make the design and construction of treatment units and distribution system as economical
- iv) To balance the rate of flow due to variation between the rate of supply and the rate of demand.
- v) In gravity system of water supply, it facilitates minimum size of pipe

2.2.5.2 Types of service reservoirs:

The service reservoirs are classified as follows

- i) Surface reservoir (or) Under Ground reservoir
- ii) Elevated reservoir (or) over head tank (OHT)

i) Surface reservoir:

They are also known as ground (or) non-elevated reservoirs. They are constructed at ground level or below the ground and are used to store water. It is usual practice to construct a surface reservoir in two compartments cleaned or repaired. The two compartments are connected with each other by control valve. Due to storage of water, silting will take place to some extent and it can be removed by occasional cleaning through the wash water pipe

The surface reservoirs are located at high point in the distribution system

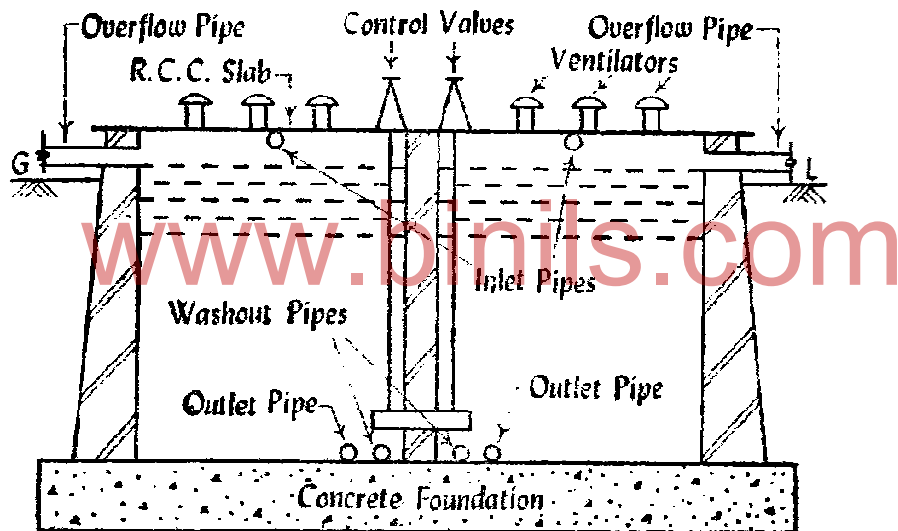

Fig 2.13 – Surface Reservoir

ii) **Elevated reservoir:(OHT)**

These are known as over head tank or OHT. They are constructed at a required elevation from the ground level. They may be of any shape – Rectangular, Circular or Elliptical by any kind of masonry, usually concrete and of steel. The elevated reservoirs are constructed in distributing areas which are not controlled by gravity system of distribution.

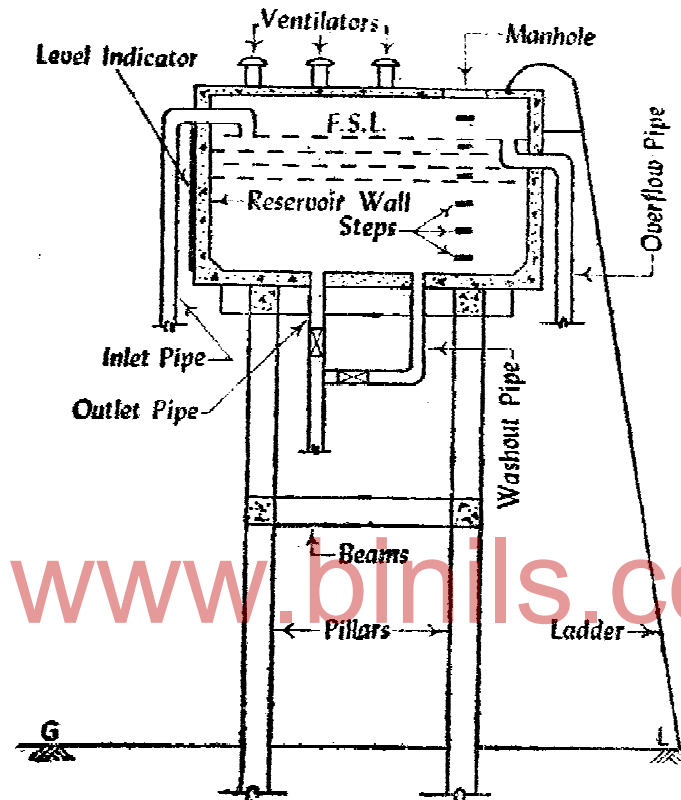

Fig 2.14 Elevated Reservoir

Review Questions

UNIT - II

PART – A (Two Marks)

1. Draw flow diagram for water treatment plant. (Oct'2017)
2. Write any two object of water treatment.
3. What is plain sedimentation?
4. What is the object of sedimentation?
5. Write any two types of sedimentation tank based on flow.
6. Give the classification of sedimentation tank according to nature of working.
7. Give the classification of sedimentation tank according to direction of flow.
8. What are the two principles of coagulation?
9. Name any two common coagulants.
10. What is service reservoir?
11. Write any two objectives of filtration.
12. What are the classifications of filters?
13. Define disinfection.
14. Name any two method of disinfection.
15. Define chlorination.
16. What do you mean by chlorine demand?
17. Define pre chlorination.
18. Define water softening.
19. Write any two necessities of water softening.
20. Name any two methods of removal for permanent hardness.
21. Name any two system of supply of water.
22. Mention the demerits of intermittent system of supplying water. (Oct'2017)
23. Name any two layouts of distribution system.
24. What are the different layouts of pipes in water distribution system?
25. Write the advantages of gravity system.
26. What is temporary Hardness?
27. What is permanent harness?

28. What is desalination?
29. What is meant by mineral water?
30. What is service reservoir?
31. Differentiate continuous and intermittent system.(any two points)
32. State merits and demerits of continuous water supply system that adopted in public water supply.
33. What is underground reservoir?

PART – B (Three Marks)

1. List out the stages of treatment of water
2. What is pumping system & mention its merits and demerits.
3. Write short notes on radial flow sedimentation tanks.
4. What is the purpose of sedimentation tanks? Where are they located?
5. Write short notes on principle of coagulation.
6. Write the merits of alum as coagulant.
7. Write short notes on theory of filtration.
8. What is meant by disinfection of water?
9. Explain any one method of disinfection of water.
10. Mention the methods of disinfection of water.
11. Define pre-chlorination and double chlorination.
12. Explain the application of bleaching powder.
13. Explain about break point of chlorination.
14. Write short notes on post chlorination.
15. What do you mean by gravity system of supply?
16. What do you mean by dead end system?
17. Explain reverse osmosis process.(Oct'2017)

PART – C (Ten Marks)

1. What is intermittent system? State the merits and demerits?
2. State the merits and demerits of continuous water supply system that is adopted in public water supply.
3. What do you mean by sedimentation? Explain any two types of sedimentation tanks with suitable sketches. (Oct'2017)
4. Explain the function of rapid sand filter with neat sketches. (Oct'2017)
5. Explain intermittent system and continuous supply of water.
6. Draw the layout of water treatment plant and explain the individual unit process.

7. Explain with neat sketch the working of a continuous flow type of sedimentation tanks.
8. What is meant by coagulant? State why alum is widely used?
9. Discuss in detail the usual coagulant which is employed for the treatment of water?
10. Explain about the working principles of rapid sand filter with neat sketch.
11. What do you mean by pressure filter and explain the working of horizontal type.
12. Explain the various methods of disinfection.
13. What is meant by chlorination? Explain in detail about the various forms of chlorination.
14. Explain briefly Reverse Osmosis process.
15. Write short notes on
 - a. Pre chlorination
 - b. Post chlorination
 - c. Break point chlorination.
16. What is the purpose of water softening? State the methods of removal of permanent hardness.
17. What are the different systems of water supply? Explain briefly under what conditions each of these systems could be adopted?
18. Explain two system Intermittent and continuous system of supplying of water.
19. What are the different systems of water supply? Explain briefly under what conditions each of these systems could be adopted?
20. Explain two system Intermittent and continuous system of supplying of water.
21. Explain briefly about layout of distribution systems with their merits and demerits.
22. Explain with neat sketches the grid iron and radial methods of layout of water distribution system
23. What is intermittent water supply system? Explain in detail.
24. Mention the various layouts of distribution in water supply system. Explain all the system of distribution layout with sketches and its advantages and disadvantages.
25. Explain briefly with a neat sketch of an elevated reservoir.
26. What is a service reservoir and what are the functions of service reservoir?
27. Explain briefly about layout of distribution systems with their merits and demerits.
28. Explain with neat sketches the grid iron and radial methods of layout of water distribution system
29. What is intermittent water supply system? Explain in detail.
30. Mention the various layouts of distribution in water supply system. Explain all the system of distribution layout with sketches and its advantages and disadvantages.
31. Explain briefly with a neat sketch of an elevated reservoir.
32. What is a service reservoir and what are the functions of service reservoir?

PART - II

UNIT III

SANITARY ENGINEERING

3.1 COLLECTION AND CONVEYANCE OF SEWAGE

(3.1:Sanitation – purpose – terms - systems of sanitation - quantity of sewage - variation in rate of flow of sewage - estimation of storm water – problems - minimum size of sewer - shapes of sewer (names only) -materials used for sewer- joints in sewer line - laying and testing of sewer lines - ventilation of sewers -cleaning of sewers)

General

In ancient days, water supply and sanitation of a community were not major problems, because the people found their own life adjusted to that sanitation of a locality. And also major cities and industries were few in numbers. Nowadays, the increasing growth rate of population, the establishment of new industries and major cities create the challenging environment to provide water supply and proper sanitation to the community.

Sanitary engineering came into existence mainly with the cleanliness of the community. To bring the community under the network of proper sanitation, huge amount of money is required. Our government has given much attention towards the proper water supply and also towards proper sanitation. Central public health engineering organization was set up under the ministry of health which gives advice to the state government for modern water supply and proper sanitation.

3.1.1. Sanitation

The fundamental principle of sanitation is healthy living in every locality as far as possible.

3.1.2. Purpose of sanitation

The main purpose of sanitation is to promote and preserve good health of people by preventing the spread of communicable diseases. This is achieved by,

- Immediate disposal of waste water from the locality.
- Proper disposal of human excrete to a safe place before decomposition.
- Disposal of sewage on land or water bodies after some treatment.
- In unsewered areas, septic tanks are used for disposing human excrete and liquid waste.

3.1.3. Definition of Terms

Sewage

It is liquid waste from the community. It contains organic matter and bacteria.

Sewer

It is the underground conduit or pipe through which sewage is conveyed.

Sullage

The liquid discharge from kitchen, bathroom, washing places, wash basins, etc., are known as Sullage. It is merely waste water and does not create bad smell.

Refuse

Refuse is the waste matter which are rejected or left as worthless from a community.

It includes garbage, sullage, sewage, storm water and subsoil water.

Garbage

It is the dry refuse which includes decayed fruits, grasses, muds, paper pieces, vegetables, ashes, dusts, etc..

Sewerage

The entire science of collecting and carrying sewage by water carriage system through sewer is called sewerage.

Sewerage system

The entire system of conduits and appurtenances involved in the sewerage is called sewerage system.

Bacteria

These are microscopic unicellular organism. These are grouped as follows.

➤ **Aerobic bacteria**

These require light and oxygen for their survival.

➤ **Anaerobic bacteria**

These do not require light and oxygen for their survival.

➤ **Facultative bacteria**

These can live either in presence or absence of oxygen, but they grow plenty in the absence of air.

Invert

It is the lower most level of a sewer.

Dry weather flow (D.W.F)

It is the normal flow during summer season. It includes sanitary sewage and industrial sewage.

Wet weather flow (W.W.F)

It is the normal flow during rainy season. It includes domestic waste, industrial waste and storm water.

Storm water

It is the rain water of a locality.

Sub soil water

Unfortunately, the ground water enters in the sewage line due to defects in sewer line. It called as sub soil water.

Sludge

It is the organic matter deposited at the bottom of sedimentation tank.

Self cleaning velocity

It is the velocity of waste water in the sewer line. In this velocity, the solid matter does not settle down at the bottom or sides of sewer pipe lines.

3.1.4. Systems of sanitation

The following methods are mainly adopted for the collection and disposal of the refuses from urban areas,

- Conservancy system
- Water carriage system

Conservancy system

It is also called dry system. In this system, the different types of refuses are collected separately and then each type is carried and suitably disposed off.

The storm water and sullage are collected and conveyed separately by closed or open channels. These are disposed in natural rivers or water courses.

The garbage is collected from road sides and conveyed by trucks to a suitable place. It is separated into flammable and inflammable matters. These are disposed by incineration and buried on land respectively. The night soil is collected from lavatories and then buried into land and is thus converted into manure.

MERITS:

- Adopted where the water is scarce.
- Adopted for small villages and towns.

DEMERITS :

- Initial cost is less but maintenance cost is more.
- Nuisance due to bad smell from the decomposed night soil.
- Insanitation occurs, during the transportation of night soil through streets.
- Unhygienic condition is developed in the removal of human excreta manually.
- More land is required for disposal.
- Risk of epidemics due to improper disposal of the night soil.
- Contamination of underground water.

Water carriage system

In this system, water is used as medium to convey the sewage to the point of its treatment or disposal in harmless manner without causing any nuisance.

The garbage is collected and conveyed as in case of conservancy system. The storm water may be carried separately or may be allowed to flow with the sewage.

MERITS:

- Most hygienic system
- The solid matters obtained after treatment can be used as manure.
- Less area is required for treatment and disposal.
- It leads to safety and compactness.
- Adopted for all areas.
- Modern methods of treatment can be given in this system.

DEMERITS:

- Initial cost is high.
- Needs sophisticated and costly treatment methods.
- The effluent after treatment should be properly disposed off, to prevent pollution of existing water resources

Comparison of conservancy system and water carriage system

Item of comparison	Conservancy system	Water carriage system
Initial cost	Less	More
Maintenance cost	More	Less
Consumption of water	Less	More
Odour	Foul smell will always be there from each latrines	There is no foul smell from water closets
Location	Latrine should be located outside the building	Latrine can be located within the building itself
Employment of labour	More	Less
Transportation	By trucks and trollies	By closed conduits
Revenue from manure	More	Less
Skilled person to supervise	Not required	Required
Cleanliness	Poor	High
Pollution of underground water	Possible	Impossible
Outbreak of epidemic	Possible	impossible

3.1.4 QUANTITY OF SEWAGE

In order to find out the suitable section for the sewer, it is necessary to determine the quantity of sewage. The sewage consists of following categories.

1. Dry weather flow
2. Wet weather flow (Storm water)

3.1.4.1 Dry Weather Flow (D.W.F)

It consists of domestic sewage and industrial waste. The quantity of D.W.F. depends upon the following factors.

1. Infiltration and exfiltration
2. Type of area served
3. Population
4. Rate of water supply

Infiltration and exfiltration

Leakage of water from the ground surrounding to sewer is called infiltration. It increases the quantity of sewage.

Leakage of the sewage from the sewer into the ground is called exfiltration. it decreases the quantity of sewage.

Type of area served

A town or city is generally classified into different areas as residential, commercial and industrial.

The residential areas may be classified as thinly populated, moderately populated and thickly populated. The amount of sewage depends upon population. In industrial areas, the amount of sewage purely depends upon the type of industries, which may be small or large. In commercial areas the amount of sewage depends upon inhabitants in these areas.

Population

In any water supply project, the future population after two or three decades is determined by applying any suitable method of population forecast. It helps in predetermination of quantity of sewage and also increases the life of project.

Rate of water supply

The quantity of sewage generated mainly depends upon the quantity of water supplied to the community, quantity of DWF is approximately equal to 70-80% of water supplied to the community.

3.1.4.1.1 Variation in rate of flow of sewage

The variation in the rate of flow of sewage affects the design of sewers. The average daily rate of sewage per head is generally varied, If the average daily rate of flow is 100l pcd (litres per capita per day) then,

- The seasonal maximum rate of flow may be 1.3 times of average daily rate of flow (130l pcd)
- The monthly maximum rate of flow may be 1.5 times of average daily rate of flow (150l pcd)
- The daily maximum rate of flow may be 1.8 times of average daily rate of flow (180l pcd)

The variations are due to many factors such as habits, climatic conditions, type of industries, level of ground water, etc.,

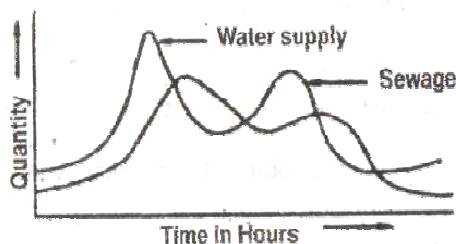

Hourly variation of water and sewage flow

In order to obtain maximum and minimum rate of sewage, the sewer is designed to carry maximum discharge and should be designed to ensure sufficient velocity to produce the required self cleaning in case of minimum flow.

3.1.4.1.2 Wet Weather Flow (W.W.F. or Storm water)

The rain water reaching the ground offer some losses due to percolation, evaporation, etc. After that the remaining water flows over the ground as storm water or storm sewage. The quantity of W.W.F. depends upon the following factors.

1. Catchment area
2. Intensity and duration of rainfall
3. Nature of soil and its porosity
4. Topography of catchment area
5. Climatic conditions

3.1.4.2 Estimation of Storm Water

The quantity of storm water is determined by using the following methods.

Rational method

This method takes into account the factors like catchment areas, impermeability of the surface and the rainfall intensity over the surface. It is suitable for small areas.

$$Q = \frac{AIR}{360}$$

Where,

- Q - Run off m³/s
- I - Impermeability factor
- A - Catchment area in hectares

Empirical method

For large area the rational method is unsatisfactory. Therefore the empirical formula should be developed based on practical experience and they are found to be satisfactory for large areas. These formulae are applied directly by assuming suitable constants for topographical features. The following are some leading empirical formulae for calculating the quantity of storm water.

Burkli-Ziegler formula:

$$Q = 296CAR \left(\sqrt[4]{\frac{S}{A}} \right)$$

Where,

- Q - Run off m³/s or liter per second
- C - Constant which depends on nature of ground surface. Its value varies from 0.50 to 0.90. (to take ave. as 0.70)
- A - Catchment area in hectares

- R - Maximum rate of rainfall over the entire area mm / hour
- S - Slope of the sewer 1 in 1000

McMath's formula:

$$Q = 292CAR \left(\sqrt[5]{\frac{S}{A}} \right)$$

Where,

Q, R, A and S are same as above.

C - Constant which depends on the nature of ground surface. Its value varies from 0.30 to 0.90.

Metcalf and Eddy's formula:

$$\text{Discharge } Q = 28.316 \left[\frac{25000}{2.471A + 125} + 15 \right]$$

Where,

Q and A are same as above.

Fanning's formula:

$$\text{Discharge } Q = 3125 M \frac{R}{100}$$

Where,

Q - Run off m³/s or liter per second

M - Area in km²

Dicken's formula:

$$\text{Discharge } Q = 14CM^{\frac{3}{4}}$$

Where,

Q and M are same as above

C- 250 for very large areas

850 for areas of average size having 600-1250mm annual rainfall

1600 for small areas.

Talbot's formula:

$$\text{Discharge } Q = 8700M^{\frac{1}{4}}$$

Where,

Q and M are same as above

Ryve's formula:

$$\text{Discharge } Q = 15CM^{\frac{2}{3}}$$

Where,

Q and M are same as above

Inglis's formula:

$$\text{Discharge } Q = \frac{123100M}{\sqrt{M+10.36}}$$

Where,

Q and M are same as above

3.1.4.2.1 PROBLEMS

Example 1

Find out D.W.F and W.W.F. of a city having the following particulars:

Area	: 30000 hectares
Water supply rate	: 200lpcd
Population	: 18×10^5
Intensity of rainfall	: 15mm per hour
Average impermeability factor	: 0.50

Assume the 60% of water supplied reaches the sewer. Comment your result.

Solution:

$$\begin{aligned} (1) \text{ D.W.F.} &= 18 \times 10^5 \times 0.60 \times 200 \text{ litres per day} \\ &= \frac{18 \times 10^5 \times 120}{24 \times 60 \times 60 \times 1000} \text{ m}^3 \text{ per second} \end{aligned}$$

$$= 2.50 \text{ m}^3 \text{ per second}$$

$$(2) \text{ W.W.F.} = Q = \frac{AIR}{360}$$

$$= \frac{30000 \times 0.50 \times 15}{360}$$

$$= 625 \text{ m}^3 \text{ per second}$$

$$\begin{aligned} (2) \text{ Combined flow (Q)} &= \text{DWF} + \text{WWF} \\ &= 2.50 + 625 = 627.50 \text{ m}^3/\text{sec} \end{aligned}$$

3.1.4.3 MINIMUM SIZE OF SEWER

Minimum size of sewers can be fixed depending upon the practice followed in the area. Normally the minimum size of sewer is 100 mm diameter for maximum length of 6 m. When the length of sewer is more, 150 mm is minimum diameter of sewer. It is desirable to lay duplicate sewer lines when sewer diameter exceeds above 3000 mm or so.

3.1.4.4 SHAPE OF SEWERS

The sewer sections are broadly classified into,

1. Circular sections
2. Non circular sections

Circular sections

Mostly circular in shape of sewer is used for all types of sewerage system. They are best suitable for diameter up to 1.5 m. Comparing to non- circular sections, they give least perimeter for a given area of flow and maximum hydraulic mean depth for running full and half-full conditions. They are very much useful in separate system, where the discharge is more or less constant.

Non-Circular sewer sections

These type of sewer sections are used in combined system. It gives more satisfactory velocity for both large and small flows. It has larger diameter and allows greater variations in flow.

Types

1. Standard Egg shaped sewer section
2. New egg shaped sewer section
3. Box or rectangular sewer section
4. Semi elliptical sewer section
5. Semi circular sewer section
6. Parabolic type sewer section
7. Horse shoe sewer section
8. Basket handle sewer section
9. U-shaped sewer section

3.1.4.5 MATERIALS USED FOR SEWERS

Based on cost, durability, resistance to abrasion and corrosion, strength and weight of the material, the following kinds are used.

- Asbestos cement sewers
- Brick sewers
- Cement concrete sewers
- Wooden sewers
- Cast-iron sewers
- Corrugated iron sewers
- Stoneware sewers
- Steel sewers
- Plastic sewers

Asbestos cement sewers

These are manufactured from a mixture of asbestos fibre and cement. They are available in sizes up to 900 mm diameter. It is light weight, easy to handle and durable against soil corrosion. They are easy to cut and join. The internal surface is smooth. They are brittle and cannot withstand impact forces.

Brick sewers

These are cast in sites. It is preferable for constructing large size combined sewers. It is particularly suitable for storm water drains. They are generally plastered on their outer surfaces so as to prevent the entry of tree roots and ground water through the brick joints and are lined with stone or ceramic blocks.

Cement concrete sewers

For small size sewers upto 600 mm diameter, plain concrete sewers may be used. Large sized cement concrete sewers may be reinforced. They can be prepared either at factory or at site. It should be free from cracks, fractures, etc., and of correct shape. It should give a clear ringing sound when struck with a hammer.

Wooden sewers

In olden days, wooden sewers were widely used. The construction and maintenance of wooden sewers are difficult. The life of wooden sewers is short and they are now rarely adopted as sewers.

Cast-iron sewers

Cast iron sewers are used when the sewers have to withstand high internal pressures and external loads. In valleys, where sewers are to be supported on piers, it is the most suitable type. They are strong enough to withstand the effects and vibrations. They are water tight and adopted under special circumstances.

Corrugated iron sewers

The corrugated iron sewers are used for storm sewers. They should be protected from the effects of corrosion by galvanizing or by bituminous coatings. It is made in varying metal thickness and in diameters upto 450 mm.

Stoneware sewers

The stoneware sewers are also known as vitrified clay sewers. They are widely used for carrying sewage and drainage, house connections as well as lateral sewers. They are available in sizes of 50 mm increments from 100 to 300 mm and in 75 mm increments from 300 mm to 900 mm. They are however, rarely made in sizes bigger than 900 mm diameter. It is cheap, smooth, durable and strong enough to take the load of backfilling if laid properly. But, they are brittle and do not withstand high internal pressure.

Steel sewers

The steel sewers are mainly used at places where lightness, imperviousness and resistances to high pressure are required. They are flexible and absorb vibrations and shocks efficiently. They are generally used for main, out fall and trunk sewers. They are protected from corrosion by galvanizing or by bituminous coatings or by using special corrosion- resistant sewers.

3.1.4.6 JOINTS IN SEWER LINE

To make a continuous sewer line, joints are necessary. The pipe joint will be decided by considering the pipe material, internal pressure, external loads, etc. Depending upon the manner of making the joint, the joints classified as follows.

1. Cement mortar joints
2. Collar joints
3. Flexible or bituminous joints
4. Mechanical joints
5. Open joints

Cement mortar joints

In this type of joint, the cement mortar of proportion 1:1 or 1:2 is inserted between the space of bell end and spigot end. In order to maintain the alignment of sewers, the gaskets or packing pieces may be placed.

The mortar is filled in the annular space formed between bell and spigot ends and the joint is finished by applying cement mortar at an angle of about 45° on the outer face as shown in Fig.

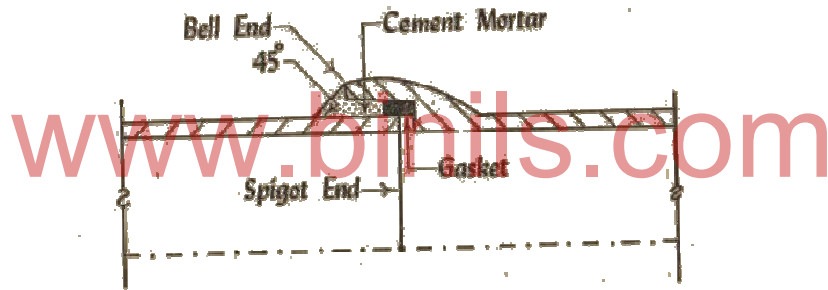

Cement mortar joint

The cement mortar joints are widely used in the construction of sewers and they are found to be satisfactory.

However some of the difficulties encountered with this type of joints are as follows.

- i. These types of joints are likely to be affected by corrosion.
- ii. A subsequent movement in the joint results in the breakage of sewer joint.
- iii. These types of joints require skilled workmanship for rigidly water tight.

Collar joints

The ends of sewer are plain used in this type of joints. The ends of sewer are placed near each other and then a collar of slightly bigger diameter is placed over the ends of sewer. The annular space between collar and the ends of the sewer is then filled with CM 1:1. It is used for sewers of large diameters.

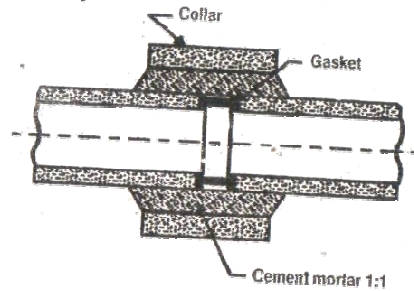

Collar joints

Flexible or bituminous joints

In this type of joint, the bitumen is used instead of cement mortar. These joints are flexible and they are adopted at places where there are chances of sewer settlement.

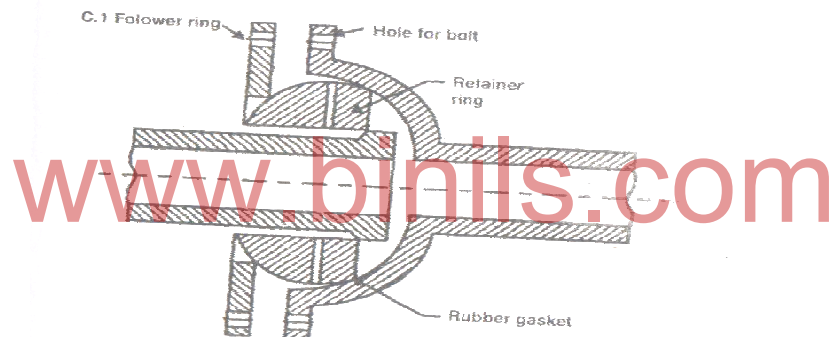

Flexible joints

Mechanical joints

In this type of joint, the mechanical devices such as rings, bolts, etc., are used to keep the two ends of sewer together. Such type of joints is generally used for metallic sewer such as cast iron, steel, etc.

Open joints

In this type of joint, the ends of the sewer are placed together or in case of pipes with bell and spigot ends. Non filling materials are inserted in the annular space formed between bell and spigot ends. The open joints are adopted for the sewer passing through dry ground. The joints are merely covered by tar paper or material like gravel to prevent the entry of earth particles in the sewer.

3.1.4.7 LAYING OF SEWER LINES

The following procedures are adopted for the laying of new sewer.

- i) To know the nature of sub soil, trial holes or borings are dug along the proposed sewer line.
- ii) The position of manholes are studied and located on the ground.

- iii) The centre line pegs of the sewer line are driven at a distance of every 7.5 m to 15 m. The distance may be adjusted as per convenience.

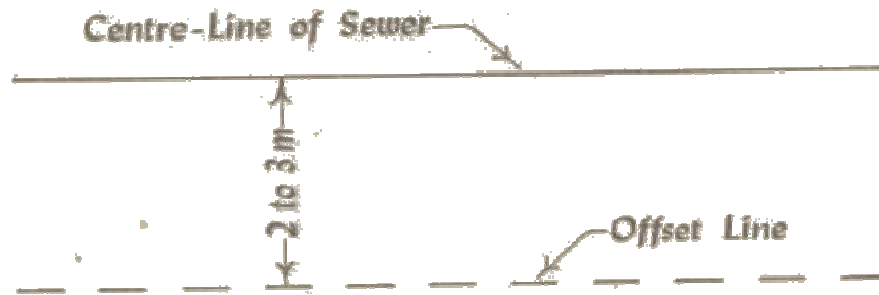

- iv) The center line of a sewer should be properly maintained by following the two methods.

- 1) In the first method, parallel line (offset) to sewer is marked at a distance of 2 m to 3 m. The offset helps in locating the sewer centre line when excavation is carried out to lay sewers.
- 2) In the second method, two vertical posts are driven into the ground at a known distance from the centre line peg. One horizontal rail known as *sight rail* is fixed between these posts at a convenient height from the ground level as shown in Fig.

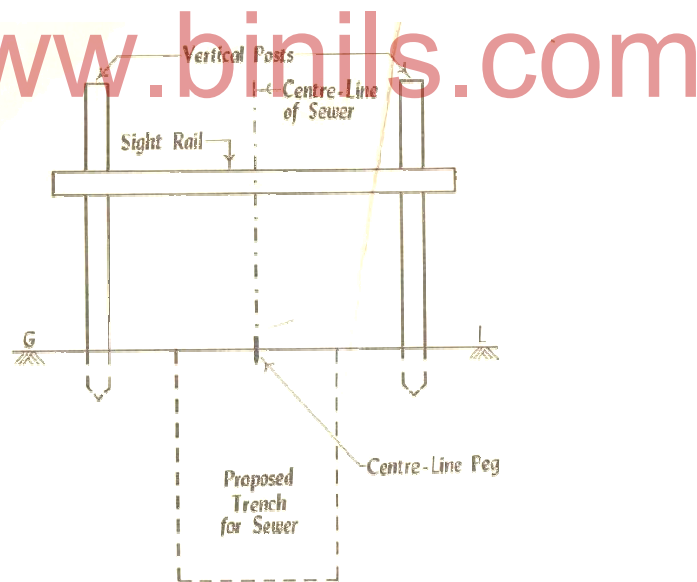

- v) The modified levels of invert at each sight rail are given and these are marked on the sight rail. These levels may be marked by fixing nails on sight rails or the top the sight rails may be adjusted to the modified invert levels of sewer line. The modified levels of invert are obtained by adding a suitable vertical length to the invert levels mentioned on the longitudinal section. Thus, an imaginary line parallel to the proposed sewer line is obtained on the ground.

- vi) Excavating trench is protected by timber on the sides. If necessary, dewatering is made in waterlogged area. The bedding layer of sewer line is required only for soft soil.
- vii) The boning rod is used to check the invert levels of sewer in the process of construction. The boning rod consists of cross head at top and shoe at bottom are shown in Fig. The length of the rod is adjusted to the vertical length of trench. The verticality of boning rod is checked by using plumb bob from top.

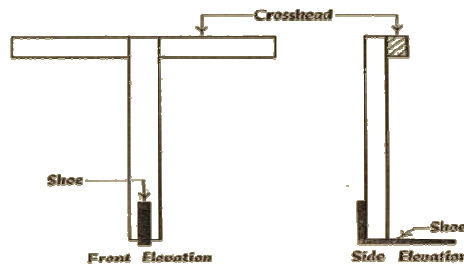

- viii) The test for water tightness of joint is then carried out.
- ix) The refilling of trenches is started after the sewer line is properly laid in position. The earth should be equally laid on either side of sewer and the filling should be carried out in layers of about 15 cm thickness. Each layer should be well watered and rammed.

TESTING OF SEWER LINES

1. Water Test

To test the water tightness of sewer line, water test carried out between two manholes is taken and the lower end of sewer line is provided with a plug.

In the manhole at upper end of sewer line, water is filled in and it is allowed to flow through the sewer line. The depth of water in the manhole is maintained at 150 cm. The sewer line is watched by moving along the trench and the joints which have sweated are repaired.

2. Obstruction Test

In this test, a smooth ball of diameter 13 mm less than the diameter of sewer bore is inserted at the high end of the sewer drain. In the absence of any obstruction, the ball rolls down at the invert of the pipe and emerges at the lower end.

3. Straightness Test

In this test, a mirror is placed at one end of the sewer line and a lamp is placed at the other end. If the pipe line is straight, the full section of the sewer is observed in the light. Otherwise this would be apparent. The mirror will also indicate any obstruction in the sewer barrel.

3.1.4.8 VENTILATION OF SEWER

Ventilation of sewer is necessary to avoid,

- Concentration of nuisance causing unpleasant odours.
- Accumulation of explosive and poisonous gases and vapours.
- Air locks.
- To relieve the air pressure above or below atmospheric pressure.

3.1.4.8.1 Methods of Ventilation

The following methods are adopted for ventilating sewers.

1. Proper construction of sewers
2. Proper design of sewers
3. Providing manholes with gratings
4. Providing ventilating columns or shafts
5. Providing manholes with chemicals
6. Providing unobstructed outlets
7. Providing forced draught

Proper Construction of Sewers

Sewers should be laid at such a gradient that will help in maintaining self-cleaning velocity in the sewer and preventing the chance of sewage staying at the point for a longer period.

Proper Design of Sewers

Always sewers are designed to run $\frac{1}{2}$ to $\frac{2}{3}$ full. The remaining space is reserved for the accumulation of gases. The proper design in sewers has the following advantages.

1. Minimize the corrosion of sewers.
2. Provide enough ventilation.
3. Avoid the pollution of underground water due to exfiltration.

Providing Manholes with Gratings

For the purpose of relieving the gases collected in the sewers, perforations are provided in the man hole cover. This method is very simple compared to other methods. But, it causes air pollution. This method is to be adopted in isolated places where air pollution does not cause any public nuisance. Unwanted things like sand, dust and storm water may also enter the sewer line through such manhole covers.

Providing Ventilating Columns or Shafts

To attain proper house drainage, the lateral sewers are ventilated independently at suitable places by ventilating shafts or columns. The diameter of ventilating column is preferably kept equal to $\frac{1}{3}$ of the diameter of sewer served by it. The ventilating column is placed at intervals of 60 to 150 m (take 100 m) apart and should be higher than the height of nearby structures. The top of ventilating columns should be covered with wired mesh called *cowl* to prevent anything directly falling into the pipe and to allow the escape of sewer gas.

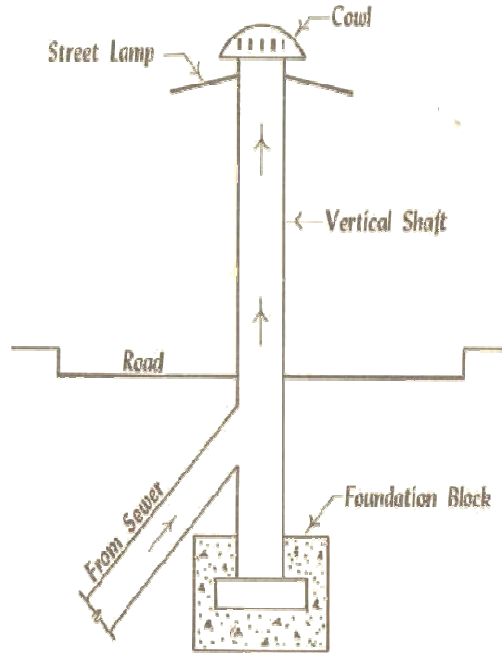

Ventilating columns

Providing manholes with chemicals

In this method, the chemicals are placed in the manhole covers. These chemicals react with the sewer gases and make them harmless. This method is costly. Hence this method is rarely adopted.

Providing unobstructed outlets

In case of storm water drains, unobstructed outlets may act as ventilation in the sewers.

Providing forced draught

To expel out the foul gases from the sewer, forced draught is provided by exhaust fans.

3.1.4.10 CLEANING OF SEWERS

The sewers should be properly cleaned and maintained in good working condition. To avoid corrosion, deterioration, erosion cleaning must be required. The following are the three important causes which make it necessary to clean the sewers.

1. Breakage of sewers
2. Clogging of sewers
3. Odours in the sewers

Breakage of Sewers

Breakage may be due to improper laying of sewers in poor soils. The breakage may also be due to shocks, vibrations etc. Further, corrosion matter slowly eats up the sewer material resulting to breakage.

Clogging of Sewers

Clogging is due to the entry of sand, grit and other building materials. Their removal will be dealt under sewer appurtenances.

Odours in the sewers

It is a common problem in sewers. The degree of odour is reduced by proper cleaning of sewers periodically and maintaining them good working condition.

3.1.1.10.1 METHODS OF CLEANING SEWERS

The following are the methods employed in cleaning of sewers.

1. Cleaning and flushing
2. Cleaning of catchpits
3. Inspection
4. Periodical repairs
5. Proper connection

Cleaning and Flushing

Large sewers are cleaned manually. Small sewers are to be cleaned by flushing. For flushing water may discharge under high pressure through small nozzle into the sewer. Automatic flushing tanks may also be installed for this purpose. When the flushing fails, the following methods are employed.

Flexible Rod: A flexible rod of about 30 m length is taken and inserted into the sewer. It consists of a flexible plate of 20 mm to 50 mm width and 3 mm thickness. It is then pushed back and forth. The movement of rod dislocates the obstructions and help in flushing. It is adopted where man can't be entered into sewer.

Mechanical Tool: A special cleaning tool is attached in the front of flexing rod. It is then pushed back and forth. The movement of rod dislocates the obstructions and help in flushing.

Pills: Pills are used in USA for cleaning of sewers. Small light hollow balls called pills are introduced first into the sewer and are followed by gradually increasing size of balls. The pills are floated in sewage and when they reach the obstruction, they are caught there. The sewage starts heading up behind then. When sufficient head is developed, the accumulation of sewage is removed. The obstructions and the pills are collected back in the next manhole.

Scrappers: The scrappers are used to cleaning small sewers to remove tree roots and other obstructions.

Shoveling: In very large sewers, cleaning is done by shoveling materials into buckets and carrying them out through manholes manually.

Cleaning of catch pits

The storm water collected in the catch pits are cleaned after every storm. The catch pits contain debris, silt, sands, etc. Even the water storage catch pits are likely to give rise to the growth of mosquitoes. A slight trace of organic matter in silt will give unpleasant odour. The oil and grease trap are also periodically cleaned to avoid the nuisance due to unpleasant odours.

Inspection

The sewer and its appurtenances should be properly inspected at regular intervals to ascertain their proper working. If cleaning is necessary, it is to be immediately carried out where needed.

Periodical Repairs

The damaged portion of sewers should be immediately repaired. The brick sewers require frequent repair. The manholes also should be periodically examined and repaired.

Proper Connection

The connection of lateral sewers with branch sewers should be carried out by authorized licensed plumbers only. The plumbing work of house drainage should be carefully done and the joints should be made watertight.

www.binils.com

3.2 SEWER APPURTENANCES

(3.2:Sewer appurtenances – manhole - lamp hole - catch basin - street inlet - grease and oil trap - flushing tanks – drainage arrangements in buildings - sanitary fittings - sewage pumps –necessity - types of sewage pumps (names only)

3.2.1 Sewer Appurtenances

In order to make the construction process easy and have efficient working and maintenance, the sewer system requires various structures known as sewer appurtenances. The following are the important sewer appurtenances.

1. Manholes
2. Drop manholes
3. Lamp holes
4. Catch basins
5. Clean-outs
6. Flushing tanks
7. Grease and oil traps
8. Inlets
9. Storm regulators and weirs
10. Inverted siphons
11. Junction chambers
12. Outlets
13. Sewage pumps

Man hole

They are the openings in the sewer line for a man to enter through it. The purpose of manhole is to inspect, clean and other maintenance operations in connection with the sewers.

The Manholes are located,

- i) At every change in gradient, direction, alignment or diameter.
- ii) At street intersection and junction of sewer line.
- iii) At intervals of 45 m to 90 m in straight reaches.

Component parts of manhole as shown in Fig.

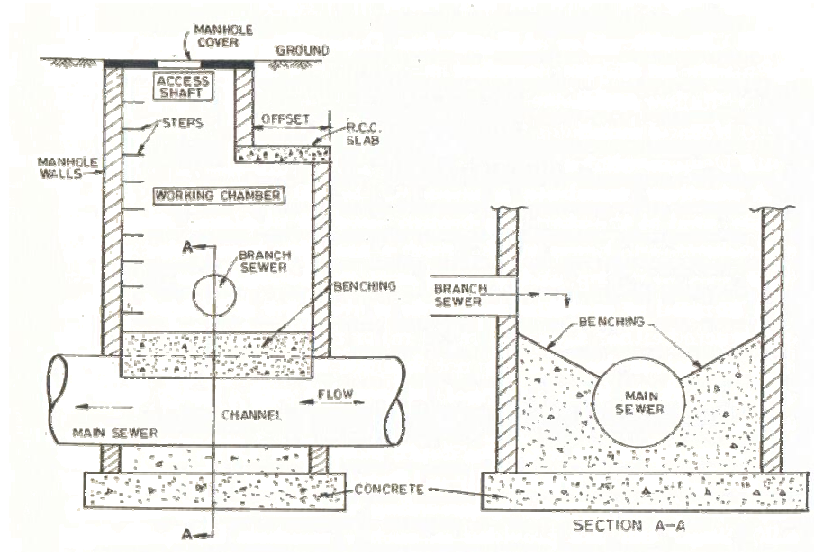

Man hole

Access Shaft: It is the upper portion of a deep manhole. It provides access to the working chamber below. The minimum size of access shaft is 50×50 cm in rectangular shape or 60 to 75 cm diameter in circular shape.

Working Chamber: It is the lower portion of the deep manhole. It provides a working space for man to stand inside and to carryout cleaning and inspection of sewer lines. It may be circular or rectangular in plan. Generally, the size of the chamber is 0.75×0.75 m upto 0.8 m depth, 1.2×0.9 m for a depth varies from 0.8 to 2.1 m depth and when a depth more than 2.1 m, the size of chamber is 1.2×0.9 m or 1.4 m diameter when circular in shape.

Bottom of Invert: It is the bottom of the manhole. It is constructed of cement concrete or brick paving, over which sewage flows.

Cover and Frames: They are provided at the top of the manhole for the purpose of entry to the manhole whenever required. During other periods, these form the surface of road. They prevent the accident of falling into the manholes. This diameter varies from 50 to 75 cm and weight is 150 kg for heavy traffic and 75 kg for light traffic.

Steps or Ladder: They are staggered in two vertical runs, 200 mm apart horizontally and 300 mm apart vertically. It is provided to make the entry and exit of men easy. They are also called rungs.

Walls: They are constructed of brickwork or stone work or cement concrete. They form the structure of manhole. They support the components above, retain the soil from the sides and enclose the sewers.

Drop man hole

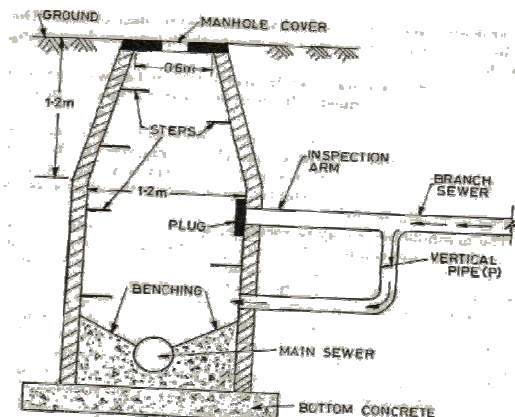

Drop man hole

The manhole in which a vertical pipe is used is called a drop man hole.

Purpose

The purpose of drop manholes is to avoid unnecessary steep gradient of branch sewer and thus reducing the quantity of earth work. Also, they avoid the splashing of sewage on the masonry work.

Location

The Drop manholes are located,

- Where the inlet and outlet pipe sewers have to be connected at different levels.
- In places where it is desired to drop the level of invert of the incoming sewer.

The length of the pipe between the vertical shaft and the wall is called inspection arm. After opening the plug, it is used for inspecting and cleaning of the vertical shaft. The vertical shaft is carried up to the ground level.

Lamp hole

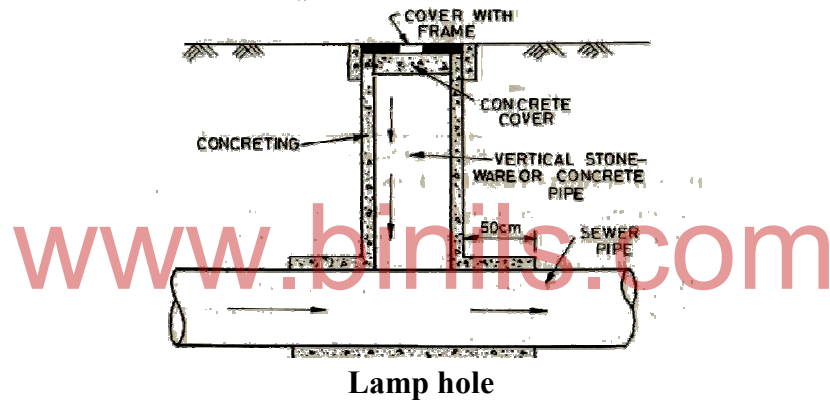

The lamp hole is intended to deduct the obstruction in the sewer. It is done by inserting a lamp in the lamp hole and viewing it from the adjacent manholes. Also they incidentally serve as fresh air inlets and for flushing. Their use should be avoided as far as possible.

The suitable locations of lamp holes are,

- In place, where bend is necessary to be inserted
- In place, where construction of manhole is difficult.
- Length between the manholes is more.
- For flushing the sewer line in the absence of any other flushing devices.

Catch basin

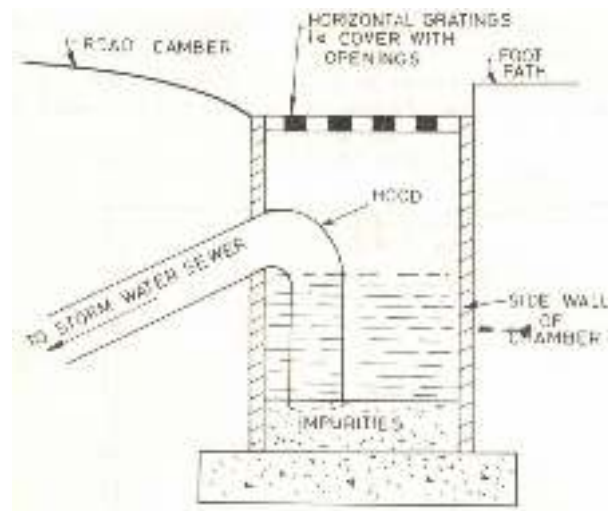

Catch basin

It is a structure constructed in the form of a chamber along the sewer line to admit the rain water into the combined sewer. It also prevents the escape of sewer gases. The silt, grit, etc., settle in the bottom and clear water alone flows into the sewer. At the top, a cover with perforations is fixed at the pavement edge. A hood is provided which prevents the escape of sewer gases into the basin. It provides a temporary storage of impurities in rain water. Hence, it is cleaned after each storm. The catch basin is shown in Fig

Street inlet

They are openings, through which storm water is admitted and conveyed to storm water sewer. They are located near the sides of the roads at 30 to 60 m centers. They are connected by pipes to the nearby manholes. They consist of concrete box with provision for admitting storm water.

They are classified as follows,

- a) Gutter inlet
- b) Curb inlet
- c) Combined inlet

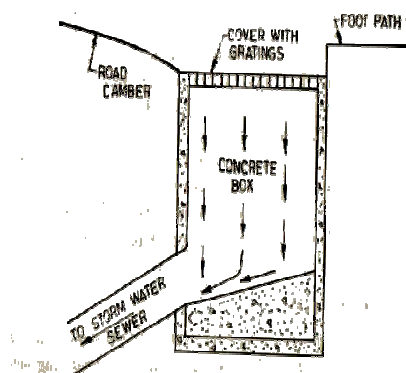

Gutter inlet

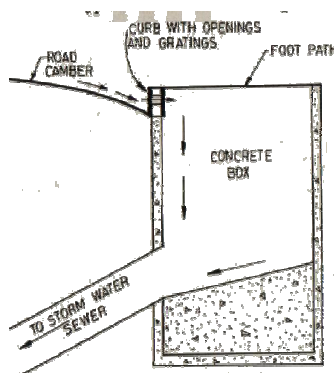

Curb inlet

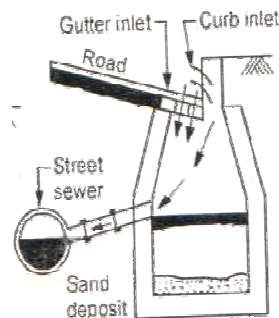

Combined inlet

Gutter inlet: In this type of inlet, a *horizontal grating* is provided at the top. These types of inlets are suitable for roads having steep slope. This inlet is also known as Horizontal inlet.

Curb inlet: In this type of inlet, a *vertical grating* is provided at the curb. It is also called vertical inlet.

Combined inlet: In this type of inlet, storm water can enter from both gutter and curb.

Grease and oil trap

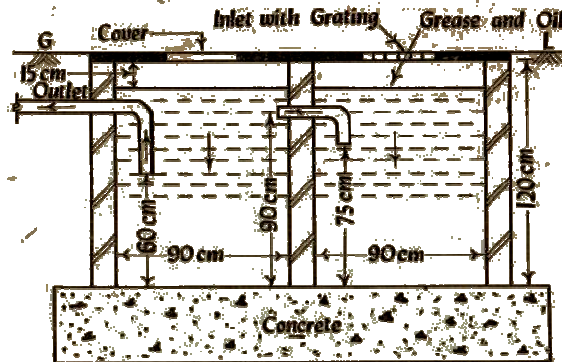

Grease and oil trap

These are chambers in sewer line to exclude grease and oil from sewage before it enters the sewer. These substances being light in weight float on the surface of sewage. If the outlet draws the sewage from lower level, oil and grease are excluded. Hence the outlet level is located near the bottom of chamber. Grease and oil traps are located near automobile workshops, grease and oil producing industries, garages, etc.

If grease and oil enter the sewers, they stick to the sides of sewer and may cause explosions. Also the suspended impurities stick to the grease. Consequently, the capacity of the sewer reduces.

Flushing tanks

These are devices used to store and throw water into the sewer to produce self cleaning velocity for flushing the sewer. Sometimes, sewage is to be stored for a short period before allowing into the sewer line. Flushing tanks are used to store sewage temporarily and then discharged at intervals to flush the sewers. They are provided at the dead end of the sewer. Their capacity is about 10% of the cubical contents of the sewer line served by it. It is classified as,

1. Hand operated flushing tanks
2. Automatic flushing tank

Hand operated flushing tank

In this case, flushing is done manually at intervals. Both outlet and inlet ends of the manhole is closed. The manhole is then opened and the water under pressure cleans or flushes the sewer line. The hand operated flushing tank is shown in Fig.

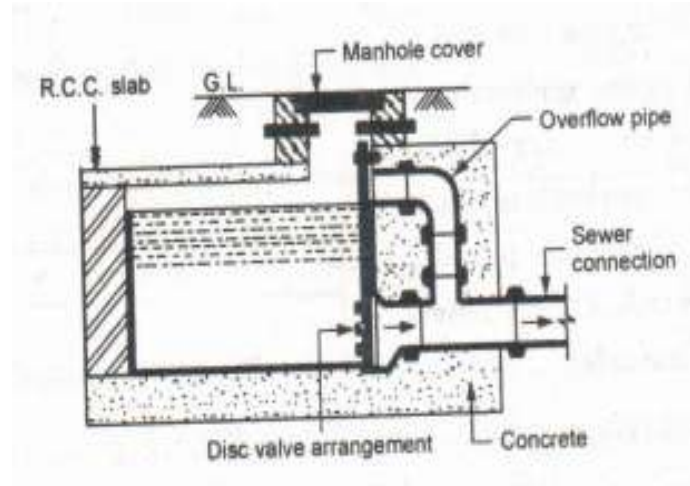

Hand operated flushing tank

Automatic flushing tank

The tank is like a manhole with a siphonic arrangement fixed at the bottom. Water supply is regulated to flow at a constant rate through a connection made in the side wall. When the tank is full, the siphon goes into operation and quickly discharges the water into the sewer.

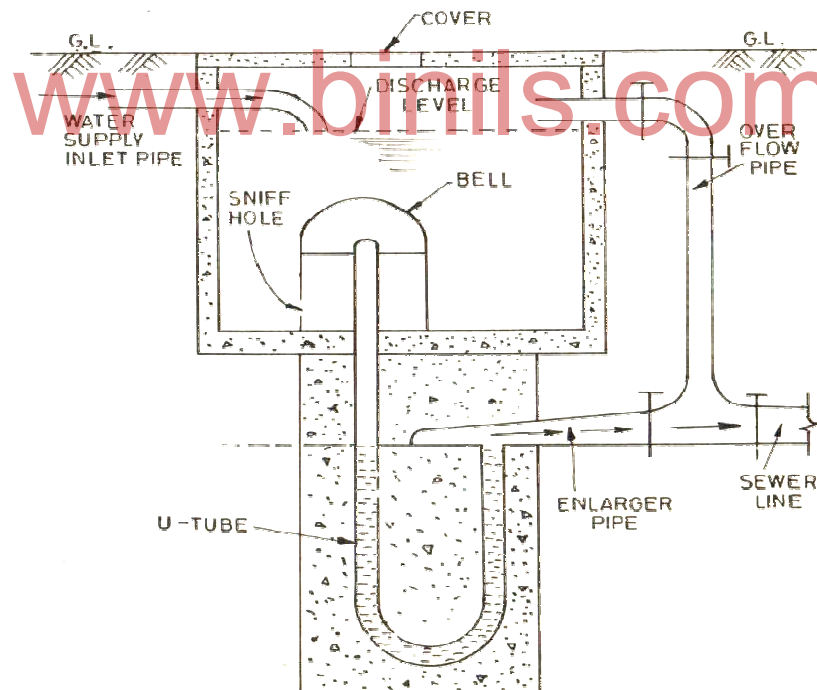

Automatic flushing tank

Working operation

The water rising above the level of the sniff hole entraps and compresses air in the bell. The compressed air of the bell presses down the water in the U-shaped trap. When the water level at the level of sniff hole goes down to the bottom of U-shaped trap, the air of the bell

bubbles out with violence. Also, water trickles out through the outer limb of the U-tube into the sewer. More water now rushes into the bell. When the water levels above the lib of the trap pipe in the bell, siphonic action begins. This action continues till water level in the tank falls below the level of sniff hole. Air again enters the bell and the siphonic action is stopped. Thus, the cycle is repeated.

3.2.2 Drainage arrangements in buildings

House drainage is the collection and conveyance of liquid refuse upto the public drain and sewers. Certain parts of the buildings are set apart for this purpose.

3.2.2.1 Principles of house drainage

1. The entrance to drains should be outside the building.
2. The drainage system has proper ventilation.
3. The drains should not pass through the building, but, should pass by the side of the building.
4. The drains should not be laid close to trees: since, they are subject to damage by their roots.
5. The drains should be laid at gradients for self cleaning. If this is not possible, automatic flushing system should be provided to them.
6. The drains should be laid straight between points of access. All changes of direction or gradient should be open for inspection.
7. Branch drain should be as small as possible.
8. The house drains should be connected to public sewer only, when the public sewer is deeper than the house drain.
9. The house drain should contain sufficient number of traps at suitable points.
10. The house drains should be separated from the public sewer by a trap to prevent the entry of foul gas into house.
11. It is preferable to provide a separate system of drains to take the rainwater.

3.2.2.2 Drainage plan of buildings

Before starting the plumbing work, it is necessary to prepare detailed plans of the proposed house drainage system for its approval from the competent authority as shown in Fig.

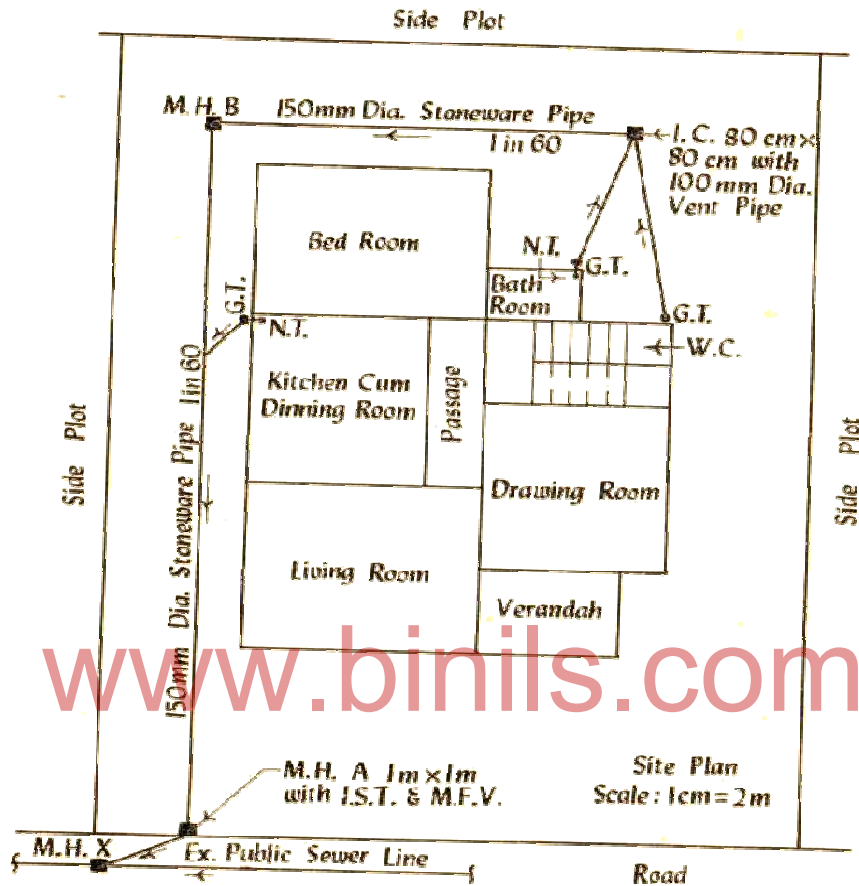

Drainage plan of buildings

The following points should be kept in mind while preparing the drainage plans.

1. The site plan of the building should be drawn to convenient scale. The positions of gully traps should be marked on it.
2. The longitudinal section of the proposed sewer line should be drawn to a convenient scale.
3. The particulars regarding distances, ground levels, invert levels, depths of cutting, sizes of chamber and manholes, size and gradients of pipes, etc., should be marked in the longitudinal sections of drains.
4. The position and level of public sewer should be clearly shown on the site plan and in the longitudinal section of drains.
5. The position of floor traps and sanitary fittings of different floors of building should be shown in the plan.

6. The house drains are laid as per the details of the approved drainage plan of the buildings.

3.2.3 Sanitary fittings

These are the sanitary appliances used to receive and discharge water, liquid or water borne waste into drainage system. The following are some of the sanitary fittings.

A) Soil fitting

1. Water closets
2. Urinals

B) Ablution fitting or Waste fittings

1. Bath tubs
2. Flushing cisterns
3. Sinks
4. Drinking fountain
5. Wash basin
6. Water closets

Bath tubs

Bath tubs may be precast or cast in situ. They are made of various materials such as enameled iron, plastic, cast iron, porcelain enameled and cement concrete or steel. They may have parallel sides or tapering sides. Figure shows the details of bath tub.

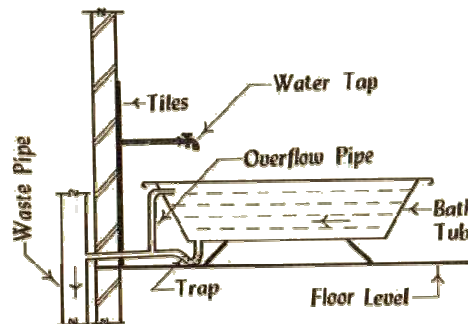

Bath tubs

It is provided with outlet pipe of 40 to 80 mm diameter and an inlet pipe for filling it. It is a height 0.9 m from the floor. In some cases, two taps are provided, one for hot water and another one is for cold water supply. The bath tubs are always provided with one over flow pipe. The waste pipe of the bath is provided with a trap.

Flushing cisterns

These are used for flushing water closets and urinals. They are made of cast iron for superior work; porcelain flushing cisterns may be used. High level cisterns are intended to operate with maximum height of 1.25 m. The height is measured between top of the pan and

underside of cistern. Low level cisterns are intended to operate at a height not more than 0.30 m. The types are,

- Bell type without valve
- Flat bottom type fitted with valve

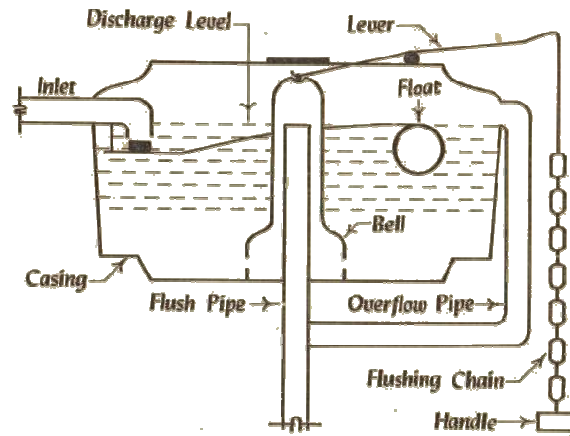

Flushing cisterns

The flushing cistern works on the principle of siphon. Fig shows the bell type flushing cistern. It consists of the following parts.

- i) A bell connected to flushing chain through lever
- ii) A float connected to inlet
- iii) Inlet, overflow and flush pipes
- iv) A casing

This type of cisterns operates on valveless siphon principle. It has a central siphon arrangement. It is actuated by pulling handle. Water from the cistern is discharged into the basin of the closet. The bell of the siphon covers the outlet pipe attached to the handle. When the flushing chain is pulled, the bell inside the cistern is lifted up by lever action. As a result of this action, partial vacuum is created at the crown of the bell. It causes water to spill over the top of the flush pipe. Siphonic action thus starts and water enters the bell through holes provided near its bottom portion. When the tank is emptied out, the float is lowered and water from inlet starts to accumulate the tank.

The discharge capacities of flushing cisterns for water closets and urinals are, 5, 10, 12.5 and 15 liters. They should discharge at an average rate of 5 liters in 3 seconds.

Sinks

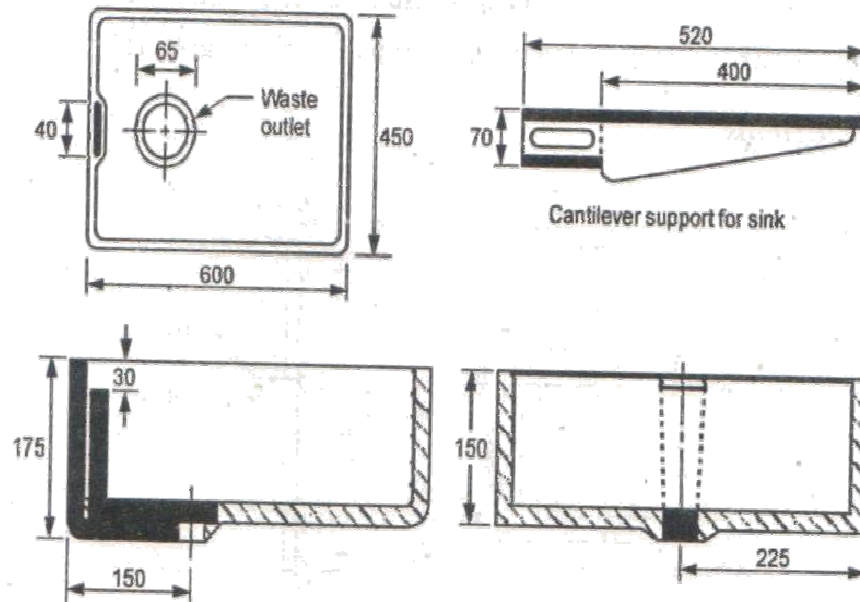

Sinks

The sinks are rectangular in shape as shown in Fig. They are used in kitchen, laboratories, canteen, hospitals, etc. They are made of glazed earthenware. They have flat bottom. Their internal corners are rounded off for easy cleaning. The usual size of kitchen sink is $0.6 \times 0.45 \times 0.15$ m and laboratory sink is $0.45 \times 0.30 \times 0.15$ m in size. They are located so that the light from the window may fall directly on them. The height of the front top edge of sink from floor should preferably 0.90 m.

Drinking fountain

In schools, public buildings, factories, etc drinking fountains are provided to supply drinking water. This is a simple arrangement and wastage of water is avoided. When the valve is pushed, the water comes from the top. After part being consumed, the remaining falls on the platform. It is conveyed to the floor trap through the grating.

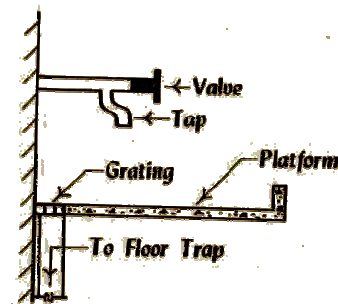

Drinking fountain

Urinals

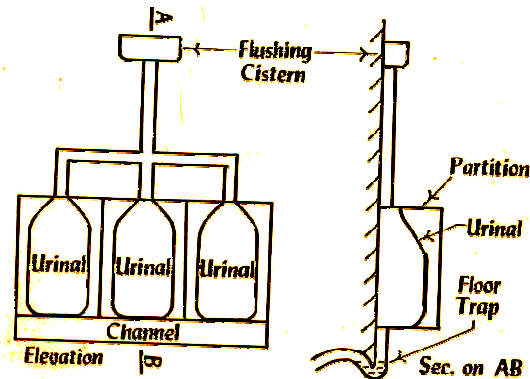

Urinals

Urinals are two types, namely stall type and bowl type. The stall type is adopted for public buildings and the bowl type is adopted for private buildings. The stall type urinals are manufactured either a urinal or as a range of two or more and are used in public places. Figure shows the details of a stall type urinal with 3 units.

The bowl type urinals are of one piece construction. Each urinal is provided with two fixing holes on the sided for fixing in the wall. At the bottom, an outlet horn is provided. It is connected to the trap.

Wash basin

A wash basin is generally made of ceramic ware, glazed earthenware or other suitable material. It is available in different shapes and shades. It is made as one piece. It may be fixed on wall with cast iron bracket or may directly rest on wall. The pedestal type of wash basin rests independently on the floor. Usually there are two taps, one is for cold water and another one is for hot water. Sometimes, it may also have only one tap. The wash basins are usually of two types namely flat back and angle back.

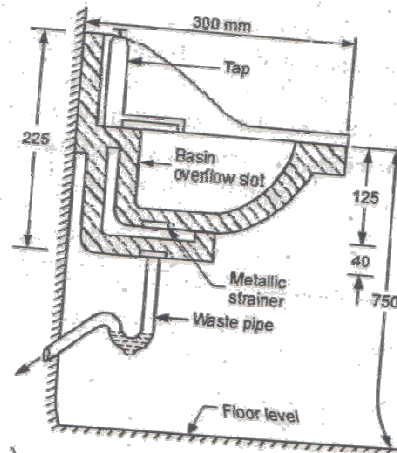

Wash basin

Water closets

It is a sanitary fitting, designed to receive human excreta directly from its user. There are two types, namely Indian type and European type.

Indian type

Figure shows the Indian type water closet. It is manufactured in two pieces, as squatting pan and trap. The pan is provided with an integral flushing cistern of suitable type. The inside bottom of the pan has sufficient slope towards the outlet for quick disposal during flushing. It is usually made of porcelain. It is connected to the flushing cistern by means of flushing pipe. The top of the trap is connected to the antisiphon or vent pipe.

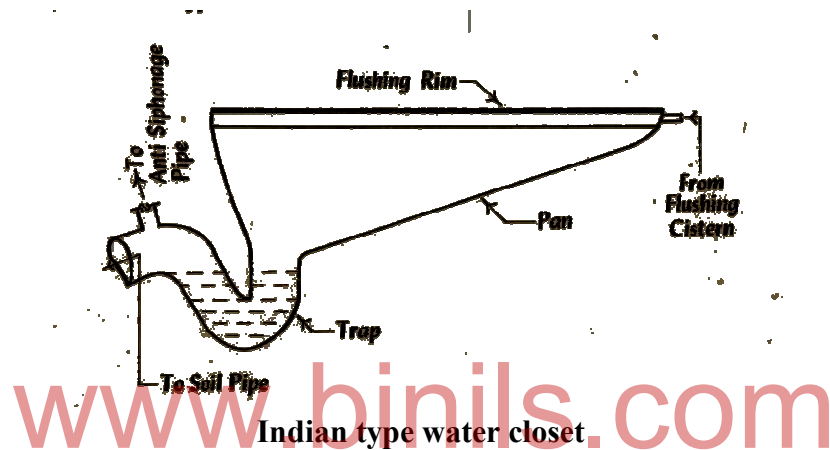

The overall length of Indian type water closet varies from 450 mm to 675 mm. The width at one end is about 150 mm. It is increased about 225 mm to 280 mm at the other end. The overall height including the trap is about 400 to 500 mm.

European type

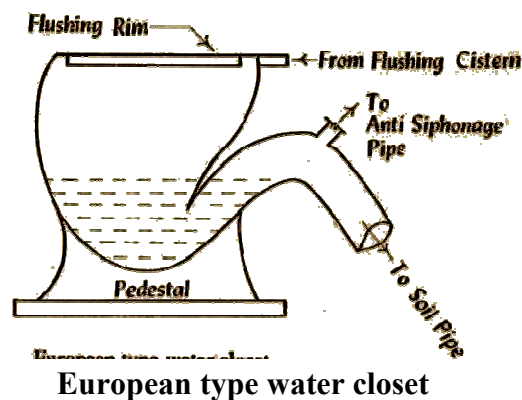

Figure shows the details of European type water closet. It is usually made of porcelain. The pan has a flushing rim to spread the flush water. At the top of water closet, a cover is provided. The overall length varies from 500 mm to 600 mm. The height varies from 350 mm to 450 mm. The pedestal type European water closet is commonly used. It is also sometimes referred to as commode type water closet.

3.2.4 Sewage pumps

To lift the sewage to the required level for a purpose of treatment or disposal, the sewage pump is necessary.

3.2.4.1 Necessity of sewage pumps

1. To assist the treatment process.
2. To lift the sewage from low lying areas to main sewer.
3. To lift the sewage from interceptors to treatment plants.
4. To lift the sewage from low lying outfall sewer to treatment works.
5. To cross the obstacles such as streams etc.,. Instead of inverted siphon.
6. To transfer the sludge from settling tank to disposal processes.
7. To recirculate the contents of the sludge digestion tanks.
8. To return the activated sludge to aeration process.
9. To drain off low lying and sub basements.

3.2.4.2 Types of sewage pumps

The types of pumps available for handling sewage may be divided into the following groups.

1. Air lift pumps
2. Centrifugal pumps
3. Pneumatic pumps or ejectors
4. Propeller pumps
5. Reciprocating pumps.

PART II
Review Questions

UNIT - III

PART – A (Two Marks)

1. Define sanitation.
2. What is the purpose of sanitation?
3. What do you mean by sanitation and what are the system of sanitation?(Oct'2017)
4. Define sewage
5. Define sewer
6. What is storm water?
7. Define sewerage
8. Define Sullage.
9. Mention the methods of sanitation.
10. Write any two advantages of water carriage system.
11. What do you mean by dry whether flow?
12. Name any two shapes of sewer.
13. Name any two material used for sewer pipe.
14. Name any two types of sewer joints.
15. Write any two advantages of cement concrete sewer pipes.
16. Write any two tests for new sewer line.
17. Write any two purpose for providing ventilating in sewers.
18. What do you mean by Manhole
19. What do you mean by flushing tank?
20. Define trap.
21. What are the types of trap?
22. Name any two types of sewer pumps.
23. Name any four sanitary fittings.
24. What is grease and oil trap?
25. What is street inlet?
26. What is lamp hole?
27. What is catch basin?
28. What are the methods of cleaning the sewer?

29. Give the reasons for selecting circular shape of sewer.
30. What are the methods for estimating of storm water?
31. What is meant by self cleaning velocity of sewage?
32. Distinguish manhole and lamphole. (Oct'2017)

PART – B (Three Marks)

1. What are the principles of sanitation?
2. Define the terms
 - a. Sewage
 - b. Sewer
 - c. sewerage
3. Define the terms
 - a. Sullage
 - b. Refuse
 - c. Garbage
4. What do you mean by D.W.F and W.W.F?
5. List out the materials used for sewers.
6. Write the different shapes of sewer. (Any three)
7. What are the requirements of a good sewer joint?
8. Why are sewers to be ventilated?
9. Why do we need ventilation of sewers? Explain any one method of ventilation.(Oct'2017)
10. Mention the methods of ventilation of sewers.
11. Why is cleaning of sewers required?
12. What is the necessity of cleaning of sewers?
13. List out the sewer appurtenances.
14. What are the principles of house drainage?
15. What are the types of traps?
16. What are the requirement of good trap?
17. What are the requirement of sewer pumps?
18. Write about lamp hole.
19. Write a note on water carriage system.
20. Give the advantages of water carriage system.
21. Explain street inlet with suitable sketch.(Oct'2017)

PART – C (Ten Marks)

1. What do you mean by water carriage sewerage system and write its advantages.
2. Explain water carriage system of carrying sewage
3. Compare the conservancy system and water carriage system.
4. Explain any two empirical formulae to determine the storm water.
5. Explain briefly concrete sewer and cast iron sewers.
6. Explain the procedure for laying and testing of sewer line.(Oct'2017)
7. Explain with neat sketches, laying jointing and testing of a new sewer line.
8. Explain with suitable sketch the jointing of a new sewer line.
9. Explain with suitable sketch the laying of a new sewer line.
10. Explain briefly the various method of ventilation of sewer.
11. Explain the drainage arrangement in building with necessary sketches.(Oct'2017)
12. Why is cleaning of sewer required? Explain the various methods of cleaning of sewers.
13. Describe with neat sketches the following
 - a. Man hole
 - b. Lamp hole
 - c. Oil & grease trap
14. Write short notes on maintenance of house drainage system.
15. Explain bath tubs and urinals with neat sketches.
16. State the necessity of sewer pumps.
17. Write short notes on
 - a. Water closet
 - b. Flushing cistern
18. Write short notes on
 - a. Collar joint
 - b. Cement mortar joint.
19. Write short notes on
 - a. Traps
 - b. Sinks.

UNIT IV

4.1 TREATMENT AND DISPOSAL OF SEWAGE

(4.1: Objectives of sewage treatment - flow diagram of sewage treatment plants - treatment of sewage - primary and secondary treatments - screens - skimming tanks - grit chambers - sedimentation tanks – filters - types and description of filters - activated sludge process - septic tanks for isolated buildings - construction and working of septic tanks - disposal of septic tank effluent – soak pits, dispersion trenches - oxidation ponds – sludge – types - methods of sludge disposal.)

GENERAL

Sewage is a dilute mixture of various types of wastes from residential, public and industrial places. Sewage contains organic and inorganic matters in dissolved, suspension and colloidal matters and also contains various types of bacteria, virus, algae, fungi etc. This sewage requires treatment in order to make it less offensive and dangerous before for its disposal. Sewage treatment is very important part of sanitary engineering because it helps in maintaining good living condition in city or town.

4.1.1 Objectives of sewage treatment

1. To protect the environment.
2. To remove contaminates present in the sewage.
3. To avoid water pollution.
4. To avoid land pollution.
5. To get fertilizers and combustible gases.

4.1.2 Flow diagram of sewage treatment plants

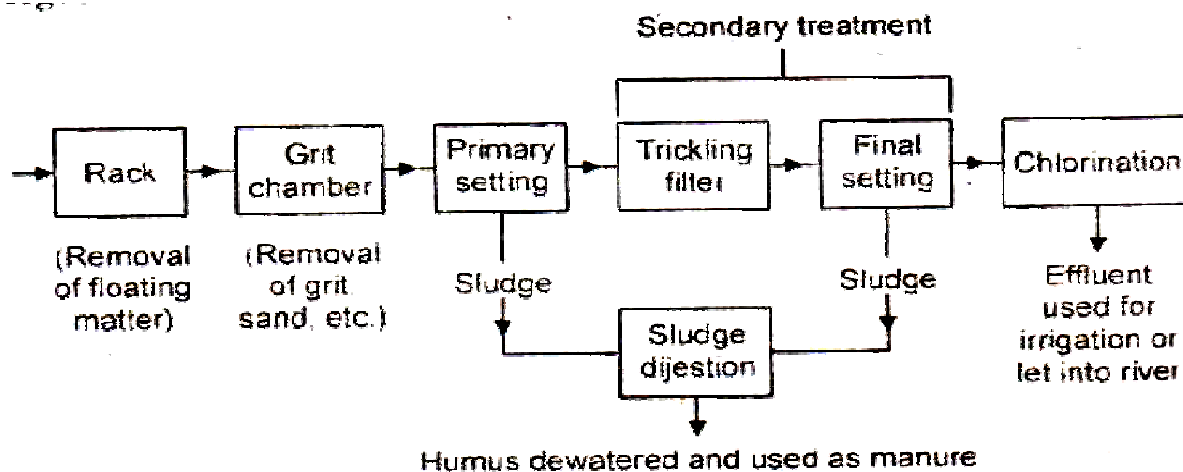

4.1.3 Treatment of sewage

Sewage can be treated in different ways. Treatment processes are often classified as:

- Primary treatment
- Secondary treatment
- Tertiary treatment

4.1.3.1 Primary treatment

This is also known as simple treatment. In this treatment, large solids and settleable organic matters from sewage are removed. In this case about 40% of total solids gets removed. The BOD reduction varies from 30 to 40%, but the dissolved solids including organic matters escape along with the effluent.

Screening, grit chamber, skimming tank, plain sedimentation tank, sedimentation aided with coagulation tank are included in this treatment.

4.1.3.2 Secondary treatment

This is essentially of biological treatment (i.e. degradation of organic matter by the agency of living organisms). In this treatment non settleable and dissolved organic matter gets removed. In this case, about 90% of total solids and 85% of BOD gets removed from the sewage after this treatment.

Contact beds, intermittent sand filter, trickling filter, activated sludge process, etc. are included in this treatment. Normally any one of the above treatment plants is adopted in a treatment process.

4.1.3.3 Tertiary treatment

This treatment removes the organic load left after the secondary treatment, and particularly kills the pathogenic bacteria. For this purpose, chlorination tank is generally used in sequence of treatment process.

4.1.4 Screens

Purpose

The main purpose of installation of screens is to remove floating or suspended matter of comparatively large size. If such materials are not removed, they will choke up the small pipes or affect seriously the working of sewage pumps.

Location

Screens should preferably be located just before the grit chamber. Screens are usually placed in an inclined position with an angle of about 30° to 60° with the direction of flow.

Types

Screens are mainly classified into two ways.

- According to size of **opening**, screens are further classified as,
 - a. **Coarse screens**– In this screens, the spacing between the bars is 40 mm or more.
 - b. **Medium screens**– In this screens, the spacing between the bars is 6 mm to 40 mm
 - c. **Fine screens**– In this screens, the spacing between the bars is 1.5 mm to 6 mm

- According to the *condition of screens*, they are further classified as,
 - a. **Fixed screens** – These screens are permanently fixed in position.
 - b. **Movable screens**– These screens are stationary in operating periods. But they can be lifted up bodily and removed from their positions for the purpose of cleaning.
 - c. **Moving screens**– These screens are moving during their operating periods and they are automatically cleaned while they are in motion.

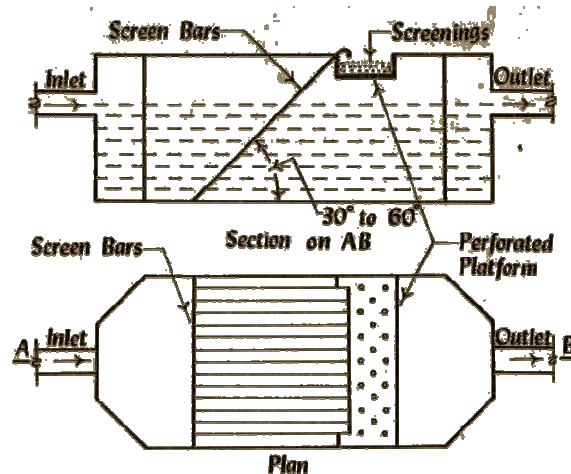

Screens

Cleaning of screens

A screen requires periodical cleaning which can either be done by hand-rakes or by mechanically operated rakes. A rake is a toothed bar. In case of hand operated rakes, laborers clean the opening of screen with rakes, twice or thrice a day. In case of mechanically operated rakes, cleaning of screening is carried out at fixed regular intervals. If the screens are continuously cleaned automatically, clogging on screens will be reduced and the screens will work with more efficiency. The cleaning of screens can also be achieved with the help of brushes, scrapers or jets of air, steam or water.

Design factors

1. The velocity of flow should be kept about 1.0m/s at an average flow of sewage.
2. The slope of screens should be at 30° to 60° in the direction of flow.
3. The maximum depth of the screen should be about 1m.
4. The detention period should be assumed as zero.

Disposal of screenings

Screenings can be disposed of easily either by burials or burnings.

4.1.5 Skimming tank

The objective of installing skimming tank is to remove lighter floating substances such as oil, grease, piece of cork, wood, fruit skins etc., from waste water. If the substances are not removed, the working of various treatment units are seriously affected.

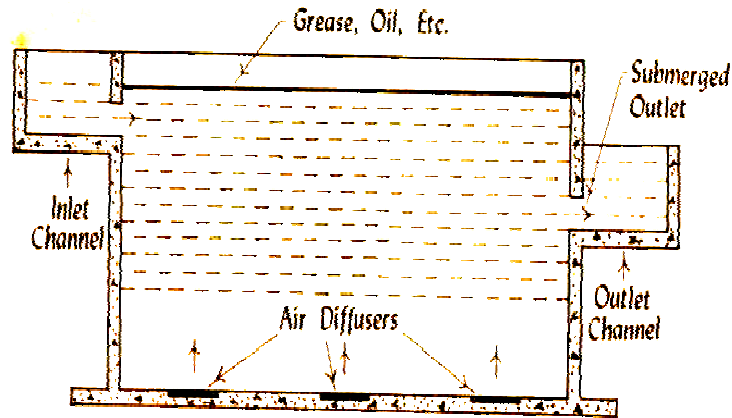

Skimming tank

Design aspects

- The detention period should be 3 to 5 minutes.
- The shape of tank is generally elliptical or circular.
- The depth of tank is about 1m.
- For efficient working, air diffusers are provided at the bottom of tank.
- Floated substances are collected in the top of tank.
- Generally submerged outlet is provided in this tank.

Disposal

Usual methods adopted for the disposal of floating substances are buried in low lying areas and burning or digestion together with sludge.

4.1.6 Grit chamber

The purpose of providing grit chamber is to remove grit such as sand, gravel and other heavy solid materials from sewage. To achieve this purpose, velocity of flow in the chamber is decreased to such an extent that the heavier inorganic materials settle down at bottom of grit chamber.

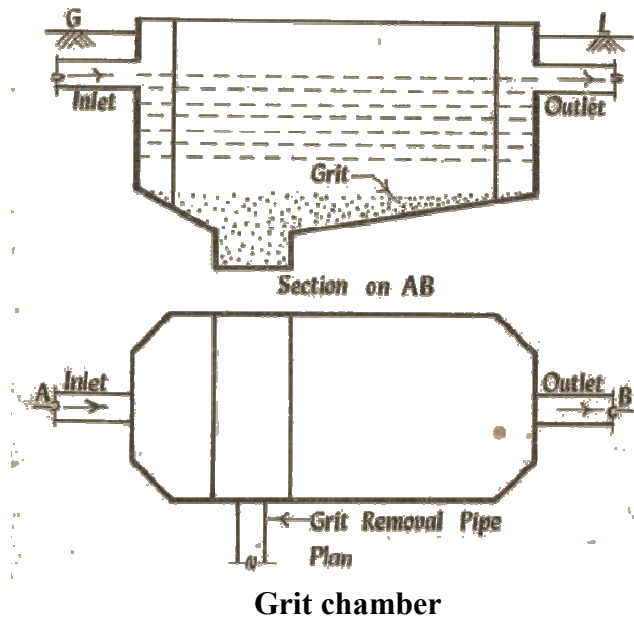

Grit chamber

Location

In general, grit chambers are placed after the pumping station and before the screens.

Number

Grit chambers are usually provided in duplicates so that anyone can be stopped from working for the purpose of cleaning.

Types

They may be,

- **Horizontal** flow type: - In this type, sewage enters and leaves the chamber in horizontal direction.
- **Vertical** flow type: - In this type, sewage enters upward direction and leaves at the periphery of chamber.

Cleaning

Grit accumulated in the bottom of the chamber is to be periodically cleaned either manually or mechanically.

Disposal of grit

Grit is generally used to reclaim the low lying land. It can be also mixed with poor soil to condition it. Soil mixed with grit work as good manure for garden crops.

Design aspects

- The detention period is about 1 minute.
- It is designed for maximum daily flow.
- The minimum depth of 30 cm should be provided below the invert level of sewer.
- The ratio of depth to length should be about 1/16.
- Velocity of flow in the chamber is kept between 20 to 30 cm/s.
- Cleaning interval of grit should vary from 1 to 2 weeks.

4.1.6.1 Detritus tanks

The purpose of this tank is same as a top grit chamber. The main idea of installing this tank is to remove fine particles then those removed by grit chamber.

Design aspects

- They are rectangular in shape, their sides are vertical and they are tapered at bottom so as to form trough for the collection of detritus.
- The overall depth varies from 2.5 to 3.5 m.
- Detention period is above 3 to 4 minutes.
- The velocity of flow is kept between 20 to 40 cm/s.

4.1.7 Sedimentation tanks

The settleable solids are separated from the sewage by allowing it to remain quiescent in large holding tanks. This operation is called sedimentation. The basin in which the flow of sewage is retarded or placed in relatively quiescent is called sedimentation tanks or settling tanks or clarifiers.

In complete sewage treatment, sedimentation is carried out at least before and after biological treatment. Sedimentation before biological treatment is called *primary settling* and that after biological treatment is called *secondary settling*.

The process of settleable solids separated from sewage by gravity is called *plain sedimentation*. If sedimentation is carried out after adding some chemicals with the sewage, the process is called *sedimentation aided with coagulation*.

4.1.7.1 Purpose of sedimentation tank

- To reduce settleable solids in the sewage by about 80 to 90%.
- To reduce the BOD in diluting water by about 30 to 35 %.
- To prepare sewage for subsequent treatment or for final disposal into water or on land.
- To reduce the strength of sewage by about 30 to 35%.

4.1.7.2 Principles of sedimentation

The principle of sedimentation tank is that particles having specific gravity more than the water will settle down and those less specific with gravity will float.

The theory based on settling velocity of spherical particle in still water is generally expressed by stokes law. It is applicable to the discrete particles. The particles which does not change in size, shape or mass during settling are known as discrete particles.

Based on the *stoke's law* the settling velocity (V_s) is expressed as,

$$V_s = 418(S_s - 1) \left(\frac{9T+70}{100} \right) d^2 \quad (\text{for particles } < 0.1 \text{ mm in dia})$$

$$V_s = 418(S_s - 1) \left(\frac{9T+70}{100} \right) d \quad (\text{for particles between } 0.1 \text{ mm and } 1 \text{ mm in dia})$$

Where,

- Vs - Settling velocity in mm/sec
- d - Diameter of particles in mm
- T - Temperature in $^{\circ}\text{C}$.
- Ss - Specific gravity of particles.

4.1.7.3 Factors affecting sedimentation

1. The size, shape and specific gravity of sewage particles.
2. Temperature of sewage.
3. Detention period.
4. Velocity and length of flow through basin.
5. Wind blowing on the surface of the liquid in the basin.
6. Depth, shape, baffling and operation of sedimentation tank.
7. Concentration of suspended matter in sewage.

4.1.7.4 Types of sedimentation tank

4.1.7.4.1 Plain sedimentation tank

Process

When the sewage velocity of flow is decreased or when the sewage is allowed to stand at rest, the suspended particles carried by the sewage tend to settle at the bottom of tanks. Material collected at the bottom of sedimentation tanks is known as sludge and the partially treated sewage is known as effluent. Sludge and effluent both require further additional treatment to make them unobjectionable.

Classification of plain sedimentation tank

I. According to nature of working

- a. **Fill and draw type:** In these tanks, sewage is filled and then allowed to rest for a certain period (usually 24 hours). During their rest period, the suspended particles settle down. The clear sewage is drawn off from the top of tank and then the tank is cleaned. The tank is refilled raw sewage to continue the operation.
- b. **Continuous flow type:** In this tank, only flow velocity is reduced. The waste water enters from one end and the effluent comes out from the other end. The detention period is increased by providing sufficient length of travel. The velocity is so adjusted that it will cause settlement of particles.

II. According to direction of flow

- a. **Horizontal flow sedimentation tanks:** In these tanks, the direction of flow of sewage is horizontal and longitudinal.
- b. **Vertical or upward flow sedimentation tanks:** In these tanks, the direction of flow of sewage is vertical.
- c. **Radial flow sedimentation tanks:** In these tanks, the direction of flow of sewage is always radial.

III. According to shape

- a. **Rectangular**
- b. **Circular**
- c. **Hopper bottom**

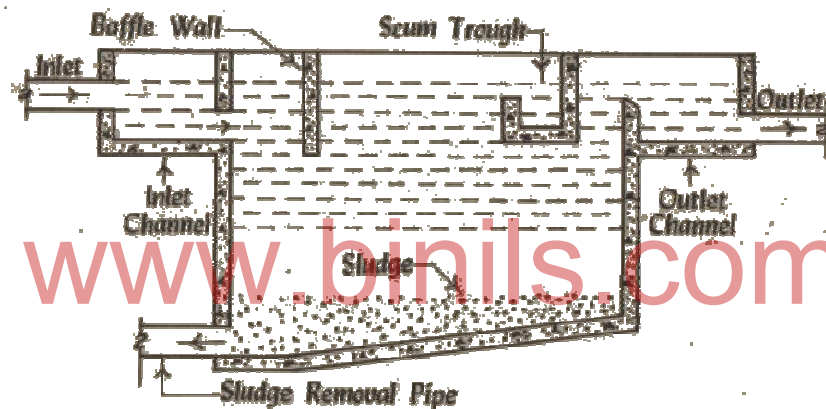

Rectangular sedimentation tank

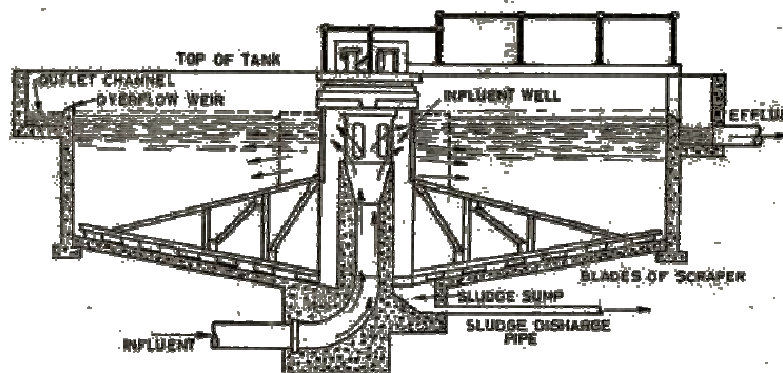

Circular sedimentation tank

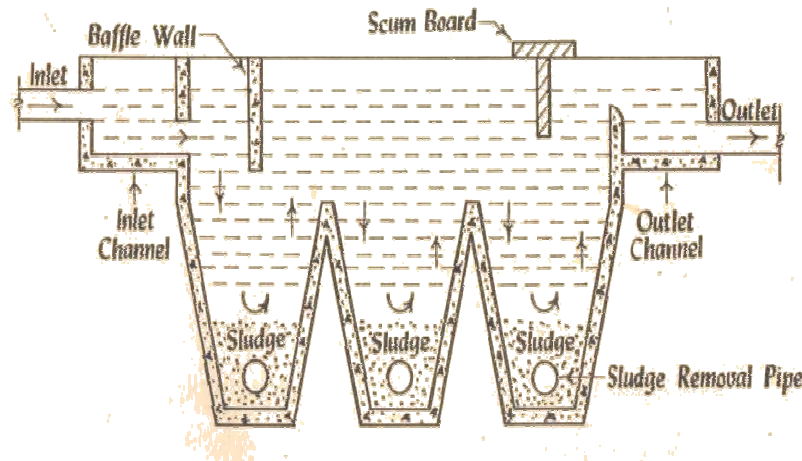

Hooper bottom sedimentation tank

IV. According to location

- a. **Primary clarifiers** - Primary clarifiers are located just after the grit chambers and they are thus provided to treat raw sewage.
- b. **Secondary clarifiers** - They are located after the units of sedimentary treatment such as filters or activated sludge process unit. They are thus provided to treat the treated sewage. They generally treat the sewage to such an extent that the effluent can directly be discharged into natural water. They are also known as final clarifiers.

Design aspects

1. Depth of tank is 2 to 2.5 m.
2. For rectangular tank, the length should be 40 to 100 m and breadth should be 6 to 7.5 m. If circular tank diameter varies from 40 to 60 m. If the tank is square, the size of tank is 25 m × 25 m.
3. Detention period is about 1 to 3 hours.
4. Velocity of flow is 0.3 m/min.
5. Overflow rate is about 40000 to 50000 lit/m²/day.
6. If secondary clarifier, the overflow rate is varied from 25000 to 35000 lit/m²/day.

4.1.7.4.2 Chemical sedimentation or sedimentation aided with coagulation

Sedimentation of sewage can be assisted by adding certain chemicals, known as coagulants. Coagulants react with colloidal matter in sewage and form the floc. The floc is nothing but insoluble gelatinous flocculent precipitation. This floc is observing and entraining with suspended and colloidal matter to help in removing fine particles completely and rapidly from the sewage. Coagulants commonly used in sewage are alum, chlorinated copperas, lime,

ferric chloride, sodium silicate and sulphur dioxide. The widely used coagulant in sewage treatment is ferric chloride, because it removes suspended solids 90 to 95% and BOD 80 to 90%.

4.1.8 Secondary treatment

The effluent from the primary sedimentation tank contains about 60 to 80 % of unstable organic matter. These organic matters that are not removed by primary treatment can be removed by biological treatment or secondary treatment. The biological treatment process includes,

- Filtration
- Activated sludge process

4.1.8.1 Filters

The filters which are commonly employed in secondary treatment of sewage are of the following four types:

- a. Contact beds
- b. Intermittent sand filters
- c. Trickling filters
- d. Miscellaneous filters

Contact beds

Theory

In contact bed sewage is kept in contact with filter media for some period. During this period, organic film produced around the particles is filter media. A large number of aerobic bacteria present in this film carry out oxidation of organic matter. In the second contact period i.e. when the bed is standing empty, filter obtains oxygen from atmosphere and organic matter caught in the voids of filtering media gets oxidized.

Construction details

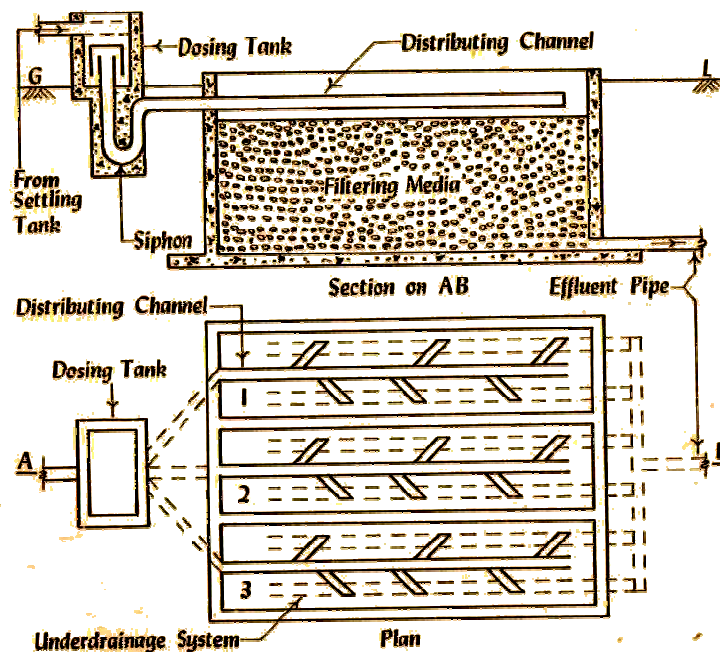

Contact beds

It is a water tight concrete tank provided with concrete lining built below ground level and the tank is filled with coarser filter media of broken stones or bricks of size 20 to 40 mm. The depth of the filter media varies from 1 to 1.8 m. A siphonic dosing tank is provided to serve two or three contact beds. The dosing tank will receive the sewage from the primary clarifiers. Sewage after passing through the filter media is collected and conveyed through the under drainage system to the effluent system. The effluent from the tank is taken to secondary clarifier for further treatment.

Generally the area of each bed does not exceed 2000 m².

Working

A complete cycle of operating a contact bed is usually carried out in the following four stages.

1. The tank is slowly filled with sewage which may take about 1 to 2 hours.
2. It is retained in the tank for about 2 hours. (i.e. first contact period)
3. Tank is then emptied by allowing the sewage to flow through effluent pipe without disturbing the organic film of bed, which may require about 3 hours.
4. The contact bed is then rested for about 6 hours. (i.e. second contact period)
5. The tank is then refilled and operations repeated. Generally one cycle of operation takes about 12 hours.

The filter media goes on clogging more and more with passage of time. Hence after 4 to 5 years, the bed becomes almost fully clogged. Therefore, the bed is removed washed and dried. Then the bed is reinstated.

Efficiency

The effluent received from the contact bed is turbid and odorless as it removes about 80% of suspended solids and 60 to 75% of BOD.

Uses

1. It can be adopted for treating sewage from small institutions.
2. It can be adopted at places where pumping of sewage is undesirable.

Advantages

1. No nuisance of filter flies.
2. No nuisance of undesirable odour.

Disadvantages

1. Primary treatment of sewage is essential.
2. Operation requires skilled supervision.

Intermittent sand filter

Theory

In intermittent sand filter, sewage is applied over the bed of finer filter media (i.e. sand filter) at regular intervals. The effluent is collected by a system of under drains. Purification of sewage effluent is effected by two actions.

1. Mechanical straining action.
2. Bacterial action takes place in the voids of sand particles.

It is more or less contact bed, the little differences are,

1. The filter media of contact bed is coarser but the filter media of intermittent sand filter is finer.
2. In contact bed concrete lining is essential around the filter media but no concrete lining is required in intermittent sand filter.

Construction details

Generally the intermittent sand filters are rectangular in shape, built below ground level and the ratio of length to width of about 3 to 4. The area of each unit varies from 20000 to 40000 m² in plan and the depth tank varies from 1 to 1.5 m. It has no lining on sides and bottom. In this tank the depth of filter media is about 0.7 to 1.05 m. The bottom of tank is given a gentle slope towards the under drains. The under drains are laid below sand bed at about 9 m spacing. Generally 3 to 4 beds are provided in each treatment plant.

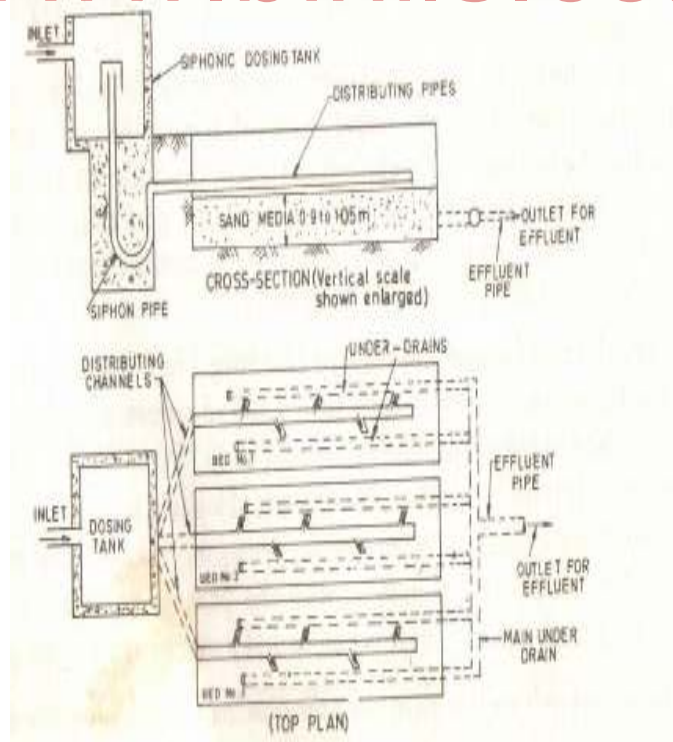

Intermittent sand filters

Working

The sewage is applied by means of dosing tank and siphon. The sewage flows into the troughs and then on sand bed through the side openings of the trough. To prevent any scouring and displacement of sand, concrete beds are also used underneath the sewage streams. The filtered sewage is collected through under drains. When septic condition occurs in the filter media, the filter is at rest about 1 to 4 weeks. For cleaning, the sand is scraped at intervals and is refilled with fresh sand.

Efficiency

The effluent from the intermittent sand filters is very clear. It contains suspended solids (less than 10 ppm) which are well nitrified and stabilised. It also has BOD less than 5 and is free from odours.

Uses

They are best suited to treat sewage of tuberculosis (TB) hospitals and hotels to give highly nitrified and polished effluent.

Advantages

1. There is no secondary sludge formed.
2. There is no odor nuisance.
3. The effluent is very clear and can be directly disposed into water courses without any further treatment.

Disadvantages

1. The construction requires larger area and much quantity of sand.
2. It cannot be used to treat the sewage for big cities.

Trickling filter

Theory

It is also called percolating filter or sprinkling filter. Sewage is allowed to sprinkle or to trickle over a bed of coarser, rough and hard material by means of spray nozzles or rotary distributors and it is then collected through the under drainage system. The purification of sewage is done by aerobic bacteria. The effluent from the filter is taken to secondary clarifier for settling out of organic matter.

Based on hydraulic and organic loadings, the trickling filters may be classified as,

1. Low rate trickling filter or standard rate trickling filters
2. High rate trickling filters or high capacity trickling filters.

Standard rate trickling filters

Construction details

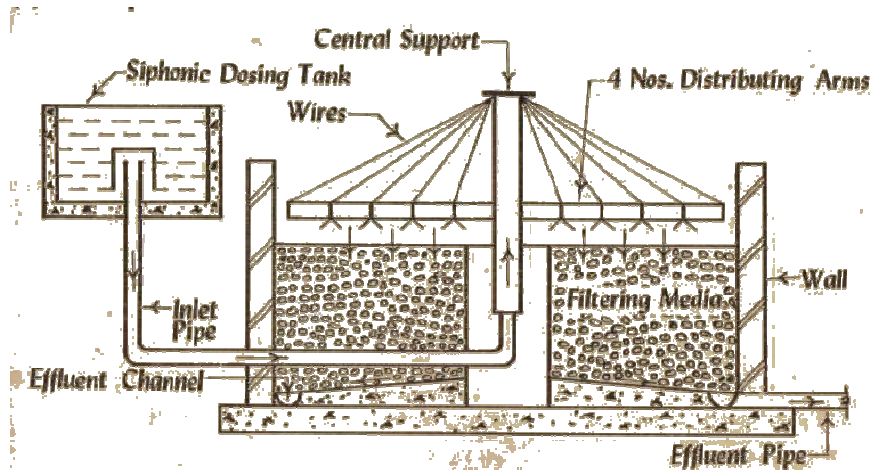

Trickling filter

- The Trickling filter constructed may be circular, square or rectangular in shape.
- The filter media used in this filter consists of coarser materials such as, crushed rock or blast furnace slag. The size of material should be between 25 to 100 mm. The filter depth for high rate trickling filters is 0.9 to 1.5 m, for low rate trickling filters is 1.8 to 2.4 m and for trickling filters that use plastic media is 9 to 12 m.
- The under drainage system consists of U-shaped half round channels, having slope of about 1 in 100 to 1 in 50 towards the drains to collect the treated sewage and for self cleaning.. Compressed air is supplied at a velocity of 0.6 m/s to the under drainage system through vertical pipes during working.
- For successful working of trickling filter, natural draft ventilation should be provided by means of providing vent pipes at the periphery of the filter or by keeping the ends of under drains open.
- Sewage is sprayed on the surface of trickling filter either by means of rotary distributor (suitable for circular filter) or rectilinear distributor (suitable for rectangular filter) or fixed distributor (suitable for small installations) through nozzles.
- Sewage is applied on the surface of filter either intermittently (2 to 2.5 minutes) or continuously by automatic siphonic dosing tanks. They receive sewage from the primary clarifiers.

Working

The sewage after primary treatment trickles over the filtering media by means of moving arms. While it moves down through the contact media, it is acted upon by bacteria. The dissolved and colloidal organic matters are precipitated and flocculated by the action of bacteria. A gelatinous film or slime layer called **zoogeal film** is formed at the surface of the contact media. The aerobic bacteria's eat up this gelatinous layer. They oxidize it and convert it to sulphates, phosphates, nitrates, etc. With passage of time, the slime layer becomes thicker and heavier. It moves towards the bottom of the trickling filter and passes out with the effluent. The

phenomenon of losing this slime layer is referred to as **sloughing**. Then, it settles in the secondary settling tank.

Loading

The following on the filter may be expressed in two ways.

- By the quantity of sewage applied per unit surface area of the filter per day. This is called **hydraulic loading** and is expressed in million liters per hectare per day. The value of hydraulic loading for *standard rate filters* may vary from 20 to 40 ML/ha/day and that for *high rate trickling filters* is 110 to 330 ML/ha/day.
- By the weight of BOD per unit volume of the filtering media per day. This is called **organic loading** and expressed in Newton of 5-day BOD per hectare-meter of the filter media per day. The organic loading for *standard rate filters* may vary from 9000 to 22000 N of 5-day BOD per hectare-meter per day and that for *high rate trickling filter* is 60000 to 180000 N of 5-days BOD per hectare-meter per day.

Efficiency

The effluent obtained from a standard trickling filter plant is highly nitrified and stabilized. The removal; of BOD is 75% and suspended solid is 80%. The sludge obtained in the secondary settling tank is thick with 92% moisture content.

The efficiency of standard rate trickling filter plant can be expressed by the expression as,

$$\eta (\%) = \frac{100}{1+0.0014\sqrt{U}}$$

Where,

- η - Efficiency of filter (In terms of % of applied BOD removed)
 U - Organic loading in N 5-days BOD per hectare-metre per day applied to the filter

Uses

It is very useful to treat the sewage in medium towns and industrial cities.

Advantages

- The effluent is highly nitrified and stabilized.
- Moisture content of sludge obtained is 92%.
- It is self cleaning.
- It is simple in operation.

Disadvantages

- Nuisance due to odour.
- Nuisance due to psychoda fly.
- It requires larger land area.
- It can't treat raw sewage. Primary treatment is essential.

High rate trickling filter

It is similar to standard rate trickling filter except that the rate of loading of high rate trickling filter is more. In this filter, recirculation system is always provided for increasing hydraulic loading of sewage.

COMPARISON OF STANDARD RATE AND HIGH RATE TRICKLING FILTER

S.No	Characteristics	Standard rate filter	High rate filter
1	Depth of filter media	1.6 – 2.4 m	1.2 – 1.8 m
2	Size of filter media	25 – 75 mm	25 – 60 mm
3	Area of land required	More	Less
4	Dosing interval	3 – 10 minutes	<15 secs
5	Interval of application of sewage	Applied at intervals	Applied continuously
6	Recirculation system	Not provided	Always provided
7	Quality of effluent	Highly nitrified and stabilized, with BOD in effluent ≤ 20 ppm	The effluent is is nitrified upto nitrite stage only and BOD in effluent ≥ 30 ppm
8	Hydraulic loading	20 to 40 ML/ha/day	110 to 330 ML/ha/day
9	Organic loading	9000 to 22000 N of 5-day BOD per hectare-meter per day	60000 to 180000 N of 5-days BOD per hectare-meter per day.
10	Quality of secondary sludge is produced	Black and highly oxidized with light fine particles.	Brown with fine particles and not fully oxidized.

Miscellaneous filters

Under special circumstances, the following filters are used.

1. Dunbar filters
2. Magnetite filter
3. Rapid sand filter

4.1.8.2 Activated Sludge Process (ASP)

Theory

The activated sludge process is an excellent method of treating raw sewage or settled sewage. The effluent from the primary sedimentation tank is mixed with 20 to 30% of own volume of activated sludge, containing a large concentration of highly active aerobic micro-organisms and sewage and with large quantity of air for about 4 to 8 hours.

The term activated sludge is the sludge which settles down after the sewage has been freely aerated and agitated for certain time. It is biologically active. It contains 95 to 97% of water. It is musty earthy in color.

Flow diagram of activated sludge process

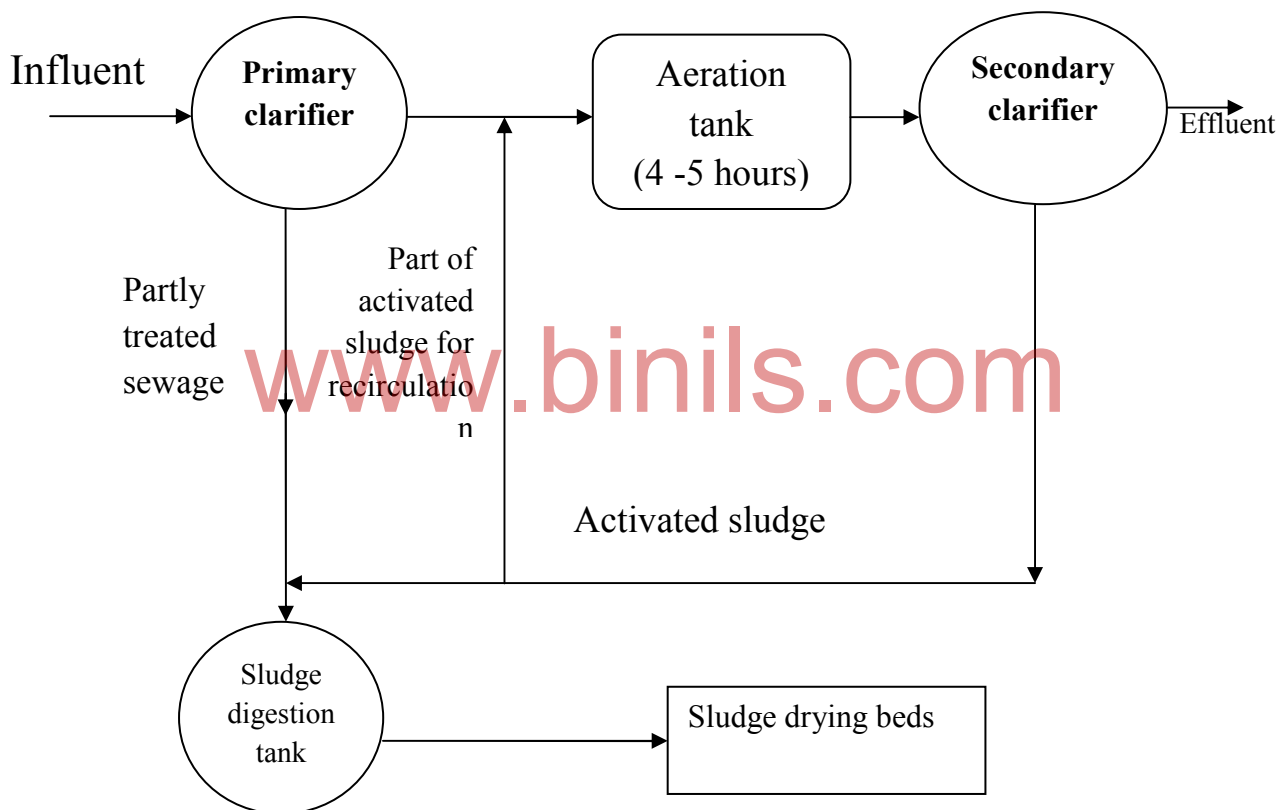

Operations

The operations involved in the activated sludge process are given below.

1. The partly treated sewage from primary clarifier is mixed with small quantity (20 -35% by volume) of activated sludge from the secondary clarifier. The mixture is known as mixed liquor.
2. The mixer liquor containing activated sludge and effluent is passed and kept agitated and aerated in the aeration tank for several hours to get stabilized biologically under aerobic conditions.

3. Aeration is achieved by diffused or mechanical aeration. Aeration helps in driving out gases from sewage. At the same time, oxygen is absorbed. This oxidizes organic matter. This produces biological mass.
4. This biological mass passes and settles in the secondary clarifier. The effluent from the secondary clarifier is clear liquid. It can be disposed of any further treatment.
5. A portion of the settled biological mass containing active micro organisms is recirculated. The rest of mass is treated and disposed of in a suitable manner. Usually, it is taken to the sludge digestion units. After digestion, it is sent to the sludge drying beds for final disposal.

Design aspects

1. Generally aeration tank is narrow rectangular in shape and has length lies between 20-200 m, breadth lies between 4 – 6 m and depth lies between 3 - 4.5 m.
2. Detention period is 4 – 8 hours
3. For supplying compressed air in the aeration tank tube, diffusers are mostly used.

Efficiency

1. BOD removal 80 – 85%.
2. Bacteria removal 90 – 95%.
3. Colloidal, dissolved and suspended solids removal 95%.

Uses

It is suitable for big cities for treating the sewage.

Advantages

1. No fly nuisance.
2. It requires smaller area.
3. The effluent is very clear and free from odour.

Disadvantages

1. Large quantity of sludge is produced.
2. Operation cost is high.
3. Skilled supervision is required.

4.1.8.3 Humus tank

These are also known as secondary clarifiers and similar to sedimentation tank. The effluent from trickling filter or activated sludge process is passed in humus tank in which all the suspended matters settle and are rapidly removed and sent to digestion tanks, either directly or through primary clarifiers.

4.1.9 Septic tank for isolated footings

In order to provide the satisfactory disposal of sewage received or obtained from isolated buildings, small institutions, big hotels, camps, etc. septic tanks may be adopted. Thus, they are suitable for isolated or undeveloped areas of the locality where municipal sewers are not laid and there is no facility to convey and treat the sewage in the public sewage treatment units or plants.

4.1.9.1 Principle

Septic tank works on the principle of horizontal continuous flow plain sedimentation tank.

4.1.9.2 Working

The raw sewage is admitted into the septic tank which moves very slowly. The flow is continuous from the inlet to the outlet. During the retention period, the solids settle down in the tank as sludge. The lighter solids such as grease, fat, etc., rise to the surface as scum. The baffle wall prevents the scum from leaving the tank with the effluent. The solids are attacked by the anaerobic bacteria and fungi. They are broken down into simpler chemical compounds. This is the first stage of purification called **anaerobic digestion**. Anaerobic digestion renders sludge stable inoffensive. The digested sludge from the tank is periodically removed and disposed off in a suitable manner. A portion of the solids is transferred into liquids and gases. The gases rise to the surface in the form of bubbles causing bad smell. Hence septic tanks are covered at the top. They are provided with a high vent shaft for the escape of gases.

The liquid which passes out of the outlet pipe is called the effluent. It is highly odorous and rich in BOD. It has finely divided solid contents with numerous highly infectious pathogenic bacteria. Therefore, the effluent requires further treatment. The effluent is allowed to percolate into the subsoil either through soak pit or dispersion trench. The aerobic bacteria present in the upper layers of the soil, attack the organic matter. The organic matter is oxidized into stable end-products i.e., nitrates, carbon-di-oxide and water. This stage of purification is called **aerobic oxidation**.

4.1.9.3 Construction details

1. The tank is rectangular in plan and the length is usually 2 to 4 times the breadth.
2. Liquid depth 1 to 2 m and free board of 0.3 to 0.45 m are provided.
3. An elbow pipe of T-shaped pipe, submerged to a depth of 150 to 225 mm below the liquid level, is provided, as inlet.
4. T- Shaped outlet pipe is provided to a depth of 150 mm below the liquid level.

5. Inlet baffle is placed at $1/5^{\text{th}}$ the length of tank from the inlet pipe. The tank is divided into two compartments. The first one serves as the stilling compartment and the second one serves as the settling compartment.
6. The floor is provided with all sides slope 1 in 7.
7. The sludging pipe of 100 to 150 mm in diameter, is provided.
8. RCC roof slab, with manhole cover is provided for inspection and maintenance.
9. Ventilation is provided by a pipe of 40 – 50 mm diameter and is taken well above the roof level and at the top, a cover is provided to prevent birds from nesting.

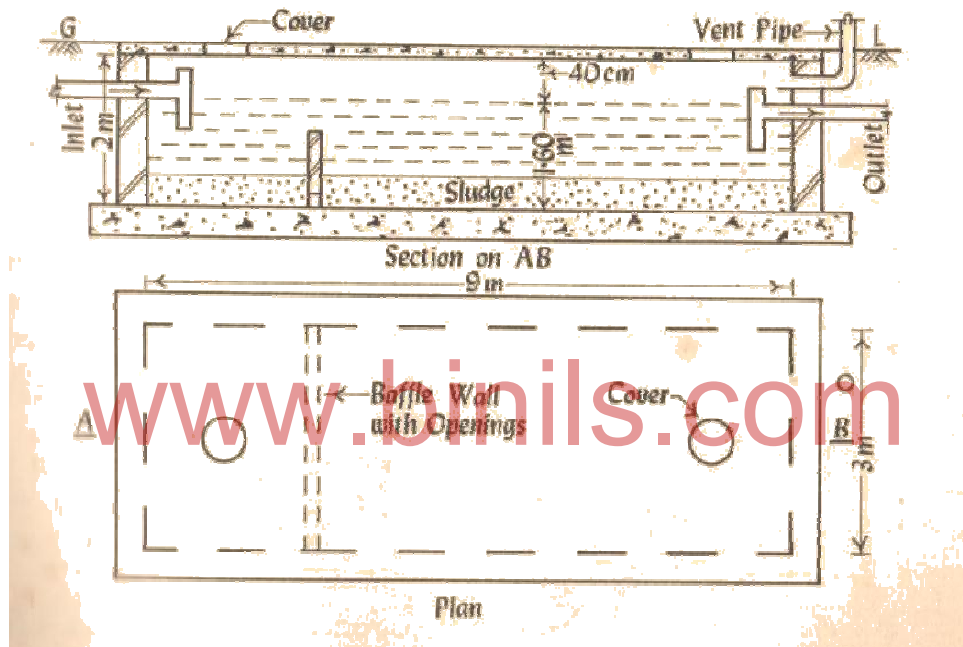

Septic tank

4.1.9.4 Operation and maintenance

1. The use of soap water and phenol should be avoided.
2. The accumulated sludge in the septic tank should be removed periodically for proper working.
3. Newly built septic tanks are first filled with water upto outlet level and seeded with digested sludge or digested cow dung to carry out decomposition process.

4.1.9.5 Design aspects

1. The clear space between upper level of sludge and lower level of tank may vary from 0.23 to 0.3 m. This clear space multiplied by plan area gives the minimum tank volume for settling.

2. The sludge digestion capacity of $0.028 - 0.056 \text{ m}^3$ per capita is made.
3. The space for storage of digested sludge is designed on the basis of period of cleaning and the number of persons using the tank.
4. For scum storage, allowances of 0.001 m^3 per capita is made.
5. Detention period generally varies from 12 to 36 hours, common being 24 hours.

4.1.10 Disposal of septic tank effluent

The effluent of septic tank is highly odorous and contains large amount of putrescible organic matter (200 to 250 ppm) and high amount of BOD (100 to 200 ppm). Therefore it should be disposed off carefully so as to cause minimum nuisance to public health. The common methods adopted for disposal of septic tank effluent are,

- a. Soak pit
- b. Dispersion trench

Soak pit

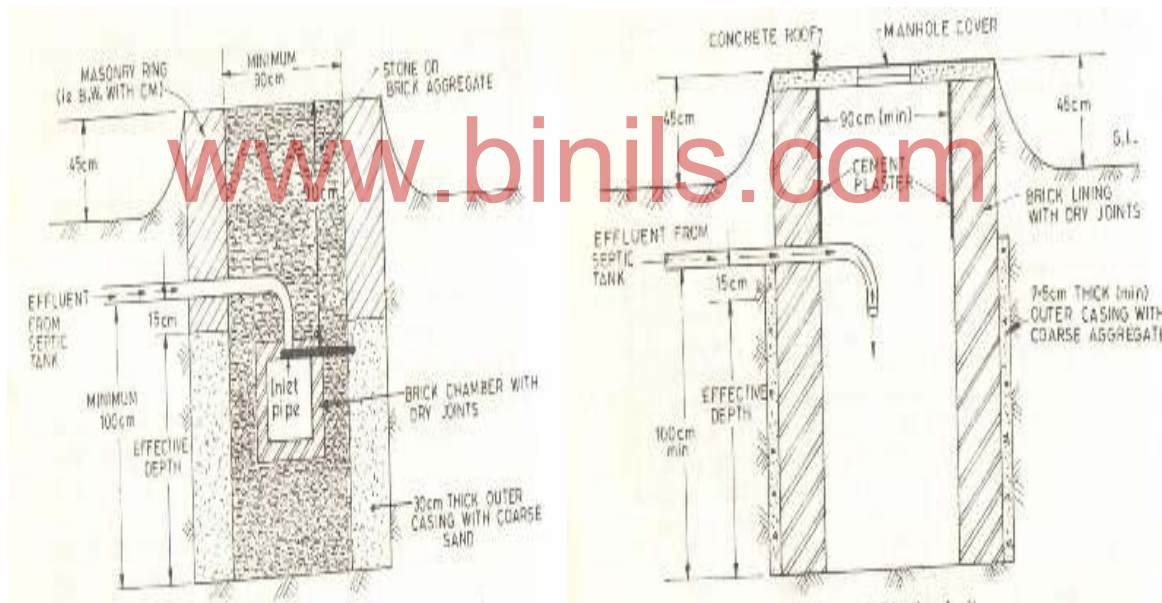

Unlined soak pit

lined soak pit

It is a hollow circular pit having depth of 1.2 to 1.8 m. The effluent is allowed into it. It gets soaked or absorbed into the surrounding soil. The pit may be kept either empty or filled up with brick bats or stone aggregates.

When empty, the pit is lined with bricks, stones or concrete blocks with dry open joints. It is provided with at least, 75 mm backing of coarse aggregate below the inlet level to support the lining.

When filled, no lining is required except for top masonry ring. Masonry lining is constructed to prevent damage by flooding of the pit by surface run off.

Dispersion trench

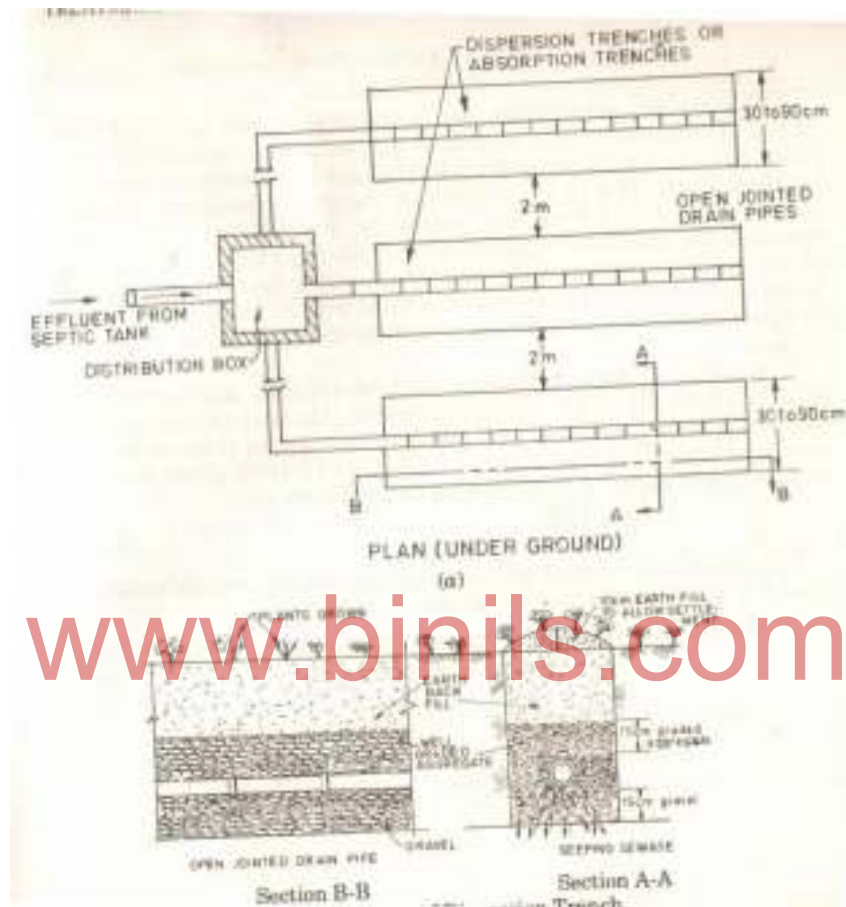

Dispersion trench

The dispersion trenches are about 1m deep and 1m wide excavated with slight gradient. The trenches are then filled with gravel, well graded aggregate and ordinary soil. The effluent from septic tank is dispersed by means of open jointed pipes laid in trenches. The effluent percolates in the surrounding media. The organic matter present in the effluent is oxidized by the bacteria present in the upper layer of soil. The clearer water gets dispersed into the surrounding soil.

Efficiency

It removes 90% of BOD and 80 % of suspended solids from the sewage.

Advantages of septic tanks

1. Easily constructed.
2. It does not require skilled supervisor.
3. The effluent is disposed on land through soak pit or cess-pool or dispersion trench.

Disadvantages of septic tanks

1. The working of septic tank is unpredictable and non uniform.
2. If the tank is not properly functioning, then the effluent is dark and fowls smelling.
3. Leakage of gases through the top of septic tanks leads to air pollution.

4.1.11 Oxidation pond

An artificial pond of shallow depth formed for the retention of sewage for sufficient time is known as oxidation pond or oxidation ditch or sewage stabilization pond or lagoon. These ponds may be used to treat raw sewage or partially treated sewage. The treatment of the latter is more popular with these ponds.

Action

Oxidation ponds purify the sewage by dual action of aerobic bacteria and algae. Sewage is stored under climatic conditions which are favorable for the growth of algae, namely, sunshine and warmth.

Working

Sewage is allowed to stay in this pond for sufficient time. The organic matter contained in the sewage is decomposed by the bacteria to simple chemical compounds like CO_2 , NH_3 and H_2O . The algae, with the help of sunlight, utilize the CO_2 , water and inorganic minerals for their growth. Thus, there is a mutually beneficial biological balance between the algae and the bacteria in these ponds. Oxygen needed for oxidation is derived by small extent from the atmosphere, but mostly from the algae which liberate oxygen under the influence of sunlight.

Construction

Oxidation ponds are constructed with shallow depth of about 90 to 150 cm. The shallow depth permits the penetration of sunlight into the body of sewage and it thus encourages the growth of algae. It is desirable to provide a free board of about one meter or so. The pond is constructed into compartments of suitable sizes and the sewage is allowed to flow in zigzag manner through these compartments.

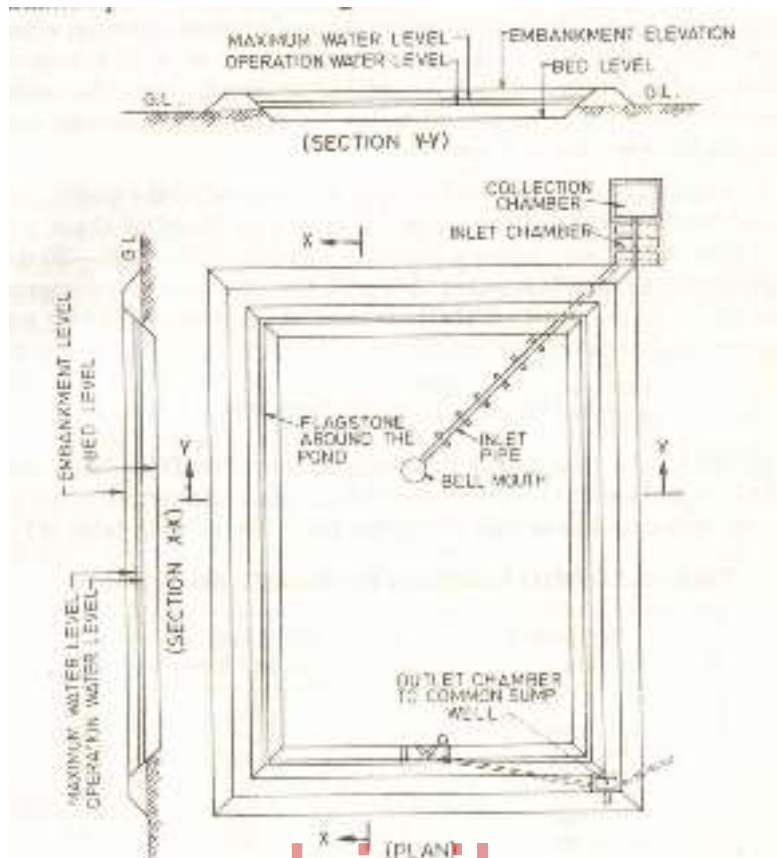

www.binils.com Oxidation pond

Design aspects

1. Length of the tank may be kept twice the width.
2. Depth may be 1 to 1.5 m and free board about 0.6 to 1 m.
3. Organic loading in hot climates is 3000 N/ha/day and in cold climates is 600 N/ha/day.
4. Area is about 1 ha/1000 persons.
5. The area of each unit may be 500 to 10000 m².

Efficiency

1. 90% of BOD is removed in this process.
2. 99% of coli forms is removed in this process.

Uses

It is suitable for small towns situated in tropical and semi tropical regions, where large areas of suitable lands are available at moderate cost.

Advantages

1. It is very cheap.
2. Maintenance cost is low.
3. Suitable for dry climates.
4. No skilled supervision.
5. Algae can be harvested and processed suitably to meet with the increased demand of proteins.

Disadvantages

1. It gives objectionable odour.
2. Nuisance of mosquitoes.
3. It is unfavorable in cloudy season.

4.1.12 Sludge

Sludge is the solid mater which is retained from sewage in both primary and secondary treatment units. It is the combination of sewage solids with different proportions of water.

4.1.12.1 Types of sludge

- Primary sludge
- Chemical precipitation sludge
- Trickling filter sludge
- Activated sludge

4.1.12.2 Methods of sludge disposal

- Disposal on land
- Distribution by pipe lines
- Drying on drying beds
- Dumping into the sea
- Heat drying
- Incineration
- Lagooning or ponding

Disposal on land

Sludge can be disposed on land by the following two methods.

1. Ploughing
2. Trenching

Ploughing

In this method, the sludge is mixed with lime water or powder and is spread on the land. When the sludge dries out, the field is ploughed. The crops can be raised on such fields.

Trenching

In this method about 600 mm deep and 900 mm wide parallel trenches are made in the field at 1.5 mc/c. The trenches are filled with sludge and covered with a thin layer of excavated earth. The process is repeated by digging new trenches between the old ones and then at right angles to the previous ones.

Distribution by pipe lines

In this method, the sludge is conveyed through pipe lines to the nearby farm and it is used as fertilizer.

Drying on drying beds

Drying of digested sludge on open beds of land called sludge drying beds is more suitable for hot and dry countries like India.

Construction

They are open beds of lands 450 to 600 mm deep. The bed consists of 300 to 450 mm thick layer of gravel varying in size from 150 mm at bottom and 12.5 mm at top. Above the layer of gravel, coarse sand layer is provided to a thickness of about 100 to 150 mm. Open jointed under drains pipes, 150 mm diameter at 5 to 7 mc/c spacing are laid below the gravel layers in valleys. The drain pipes are laid at a longitudinal slope of 1 in 100. The beds are about 15 m × 30 m in plan. They are surrounded by brick walls of height 1 m above the sand surface.

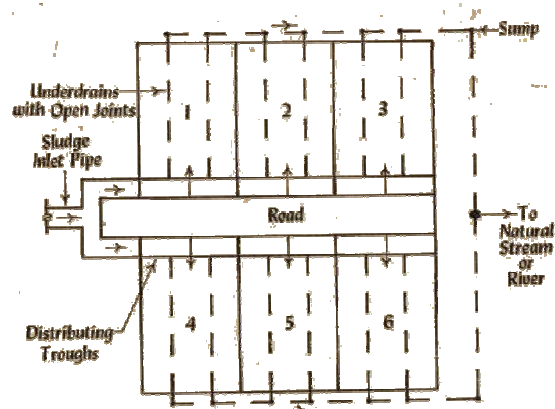

Plan of drying beds
FIG. 14-1

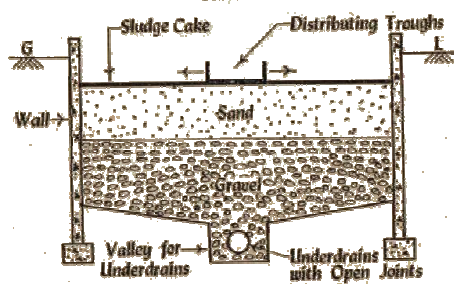

Drying beds

Operation

www.binils.com

The sludge is spread over the drying beds to a depth of about 200 to 300 mm through distribution troughs having opening of about 150 mm × 200 mm at a distance of about 2 m. A portion of moisture drains through the beds, while most of it is evaporated to the atmosphere. In some instances, a glass roof is built over the beds to give protection against rain and snow. Sludge should never be applied to a bed until preceding dose has been removed. Normally dried sludge is removed from the beds after a period of about 7 to 10 days. Within this period, about 30 % of moisture goes away and surface of sludge gets cracked. Then the sludge cakes are removed by spades and or dumped into a pit for further drying. The dried sludge is generally used as manure. It may also be used for filling up low lying areas.

Dumping into sea

In this method, sludge is conveyed and discharged into the sea. The sludge should be taken sufficiently far away from the shore so as to avoid any chances of possible nuisance by the

sludge being washed back to the shore. This method is suitable in the case of cities situated on sea shores.

Heat drying

In this method, sludge is heated and gets converted into manure. This method is commonly adopted in developed countries for producing fertilizers from the sludge obtained from ASP.

Incineration

The sludge may be incinerated, where fertilizing value of sludge is not to be preserved. In this method, first the sludge is heat dried and then kept in furnace. The sludge is ignited and burnt to ash.

Lagooning or ponding

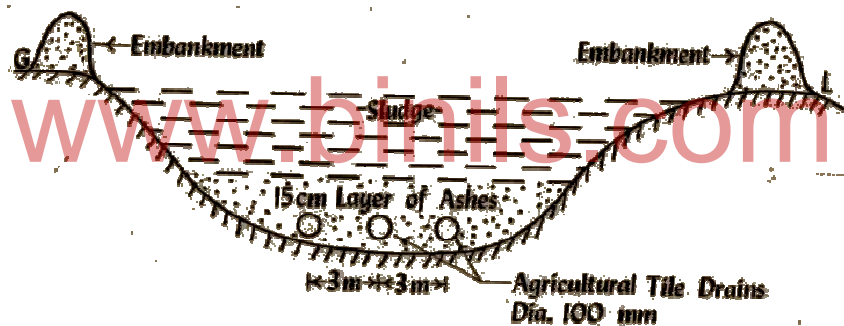

Lagooning or ponding

Lagoon is a shallow pit, 0.6 to 1.2 m deep, formed by excavating the ground. At the bottom of lagoon, a 150 mm thick layer of ash is placed. The agricultural tiles under drains of 100 mm diameter are placed at a spacing of 3 m in the ash layer. Embankments are formed from the excavated materials. The untreated and digested sludge is deposited in Lagoon. It may stay there for 1 to 2 months or even upto 6 months. The sludge undergoes anaerobic and aerobic digestion and gets stabilized. Due to the decomposition, foul gases are evolved from lagoon. Hence lagoon should be located away from highways and dwellings at leeward side to minimize possible odour nuisance.

4.2 SOLID WASTE MANAGEMENT

(4.2:Solid waste – classification - collection and conveyance of solid waste - disposal of solid waste – necessity - reduction and reuse of solid wastes - methods of solid waste disposal - incineration, dumping, sanitary landfill , composting - energy from waste.)

4.2.1 Solid waste

Solid waste means unwanted waste materials from houses, hospitals, commercial, industrial and agricultural operations and others arising from man's activities.

The constituents of an average solid waste are given below:

Paper	-	31.3%	Textiles	-	1.4%
Glass	-	9.7%	Wood	-	3.7%
Metals	-	9.5%	Food	-	17.6%
Plastic	-	3.4%	Yard waste	-	19.3%
Rubber	-	2.6%	Other organic waste	-	1.5%

4.2.2 Classification of solid waste

S.No	Source	Types of solid waste produced
1	Residential buildings	Food wastes, rubbish, ashes, vegetables wastes, etc
2	Commercial building	Food wastes, rubbish, ashes, demolition and construction wastes, etc.
3	Municipal building	Same as above
4	Industries	Same as above
5	Treatment plant	Essentially residual sludge
6	Agriculture area	Agricultural wastes, pesticides, chemicals, fertilizers, spoiled food waste, etc.
7	Hospitals	Contaminated needles, bandages and expired drugs
8	Nuclear power plant	Radioactive waste

4.2.3 Collection and Conveyance of solid waste

Collection includes gathering of solid wastes and hauling wastes to the location where the waste is emptied.

Proper planning of collection systems and routes, training of workers and maintenance of equipment are necessary for the satisfactory collection of refuse. While transporting the waste, care should be taken to avoid the physical contact between the labour and the waste matter.

Usually, the refuse is collected in closed water tight trucks or tractor trailers and taken out of the town for disposal. Now-a-days, hydraulically back unloading type dumpers are commonly employed for refuse transportation. The route of refuse collection should be decided, so that the distance hauled by the fully loaded vehicle to the point should be as short as possible. Frequency of collection is kept such that the refuse may not start giving nuisance by odour and fly breeding. From cities, the refuse should be collected daily except holidays. The collection of refuse from business areas should be done in non working hours, preferably in the nights to avoid nuisance. In case of residential areas, it may be done in daytime to avoid noise nuisance and difficulty in the location of refuse bins.

www.binils.com

4.2.4 Disposal of solid waste

The disposal should be done far away from cities, using engineering principles to confine the wastes to the smallest possible area to reduce them to lower practical volume and to prevent them from attack from rodents and vermins.

4.2.4.1 Necessity of solid waste disposal

- The organic portion of solid wastes ferments and favours fly breeding.
- The garbage in the refuse attracts rats.
- The pathogens may be conveyed to man through files and dust.
- There is possibility of water pollution, if rain water passes through deposits of fermenting refuse.
- There is risk of air pollution or fire accident, if there is accidental or spontaneous combustion of refuse

4.2.4 Reduction and Reuse of solid waste

REDUCE

Reducing the amount you buy is the most significant of all the options to manage waste. The key is to only purchase goods that we need and in the right amount. If we never generate products in the first place, we do not have to extract raw resources, manufacture goods from scratch, come up with shipping materials, utilize additional resources for shipping, and then devise ways to dispose of them

Reduce: What Can We Do?

Each person adds to the waste management problem. If each household reduces its waste, the problem will be reduced. You can start by analyzing what you throw away and what goods are needed at home. The main steps consumers can take to reduce waste are:

- Choosing items that you need, not want
- Shopping for high-quality items
- Using minimum packaging: Packaging materials like plastic bags
- Buying local products

REUSE

The idea of being wasteful makes many people uncomfortable. How long does it take to decompose (EPA, 2013a)? Paper towel 2–4 weeks, Plastic bag 10–20 years, Newspaper 6 weeks, Plastic film container 20–30 years, Apple core 2 months, Tin can 50 years, Waxed milk carton 3 months, Rubber boot sole 50–80 years, Plywood 1–3 years, Styrofoam plastic cup 50 years, Wool sock 1–5 years, Aluminum can 80–200 years, Cigarette butt 1–5 years, Disposable diaper 450 years, Plastic beverage bottle 450 years, Monofilament fishing line 600 years, Glass bottle 1 million years, door that was scratched by a favorite pet. We are conditioned to think of things that are old, empty, worn, broken, ugly or marred as useless, so we throw them away without much thought about the consequences. The process of reusing starts with the assumption that the used materials that flow through our lives can be a resource rather than refuse.

Reuse: What Can We Do?

The following are some examples of reuse.

- Containers can be reused at home or for school projects.
- Reuse wrapping paper, plastic bags, boxes and lumber.
- Give outgrown clothing to friends or charity.
- Buy beverages in returnable containers.
- Donate broken appliances to charity or a local vocational school, which can use them for art classes or for students to practice repairing.
- Offer furniture and household items that are no longer needed to people in need, friends, or charity.
- Sheets of paper that have been used on only one side can be used for note-taking or rough drafts.
- Old, outdated furniture can be reupholstered or slipcovered. Have padding added to the furniture to give it a new look. Often the frame can be modified slightly to change the way it looks.
- Old towels and sheets can be cut in small pieces and used for dust cloths.
- Books and magazines can be donated to schools, public libraries or nursing homes.
- Newspapers can be donated to pet stores.
- Packing materials such as polystyrene, plastic quilting and similar materials can be saved and reused again for packing.

- Carry a reusable tote bag or take bags to the store when you go shopping. There are attractive nylon mesh bags available that can be stored easily in the glove compartment of your car. Durable canvas bags, which take very little space to tuck away when not in use, can also be used.

- If you buy prepared microwaveable dinners, save the plates for outdoor parties or for children.

- Old tires can be used in the garden and in the play yard.

4.2.5 Methods of solid waste disposal

The principal methods of refuse disposal are the following,

- Dumping
- Sanitary land filling
- Incineration
- Compositing
- Ploughing in fields
- Salvaging
- Grinding and discharging into sewers
- Fermentation or biological digestion

The choice of particular method is governed by local factors such as cost, availability of land and labour.

4.2.5.1 Incineration

It involves burning of combustible refuse in an incinerator. All sorts of bacteria, insects, etc., are destroyed and the remaining non combustible ashes, metals, etc., have little sanitation problems. The heat produced during burning of the refuse can be utilised for the production of steam and other purposes. It is the most sanitary method of disposal of refuse. It is recommended for crowded cities and populated areas due to lack of suitable land. However, because of the larger amount of smoke and gas emitted in this process, it adds considerably to the air pollution problem.

4.2.5.2 Dumping

In this method, the refuse is dumped in low lying areas partly as a method of reclamation of land. As a result of bacterial action, refuse decreases considerably in volume and is converted into humus.

The method though popular in cities, is not quite satisfactory because of the following drawbacks.

- The refuse is exposed to flies and rodents.
- It is a source of nuisance from smell and unsightly appearance
- The loose refuse is dispersed by the action of wind
- Drainage from dumps contributes to the pollution of surface and ground water.

4.2.5.3 Sanitary landfill

This is simple, effective and cheap method of refuse disposal. In this method, 3 to 5 m deep and 6m wide trench is excavated. It is filled up with refuse to a depth of about 2 to 2.5 m. The refuse is compacted and covered with 1 to 2 m layer of excavated earth. Such earth sealing prevents infestation by flies and rodents and suppresses the nuisance of smell and dust. The micro organisms slowly start the decomposition of the organic matters of refuse and convert them into stable compounds.

4.2.5.4 Compositing

Compositing is a method of combined disposal of refuse and night soil or sludge. It is the process of nature. In this, organic matter breaks down under bacterial action. This results in the

formation of a relatively stable humus like material called compost. This method is popular in India. The following are the composting methods now in use.

1. Bangalore method
2. Indore method
3. Mechanical compositing

Bangalore method (Anaerobic composting)

Compositing is carried out by anaerobic method popularly known as Bangalore method. In this method, trenches of 4.5 to 10 m long, 1.5 to 2.5 m wide and 0.9 m deep are dug. The pits should be located on the leeward side by not less than 800 m away from the city limits. The trenches are alternatively filled with layers of refuse (150 mm) and night soil (50 mm) till the heap rises to 300 mm above ground level.

The top layer should be of refuse, at least 250 mm thickness. Then the heap is covered with excavated earth. Within 7 days, as a result of bacterial action, considerable heat (upto 70⁰C) is generated in the compost mass. This intense heat persists over 2 to 3 weeks. This serves to decompose the refuse and night soil and destroy all pathogenic and parasitic organisms. At the end of 4 to 6 months, decomposition is completed. This resulting manure is high manorial value.

Indore method (Aerobic composting)

A modification of Bangalore method is the aerobic method called Indore method. In this method, trenches of 4.5 to 10 m long, 1.5 to 2.5 m wide and 0.9 m deep are dug.

The pits should be located on the leeward side by not less than 800 m away from the city limits. The trenches are alternatively filled with layers of refuse (150 mm) and night soil (50 mm) except that top 600 mm portion of trench is left unfilled. Turning of the mass is done at an interval of 5 to 7 days twice or thrice thereby enabling material both outside and inside to be fully decomposed aerobically under the action of atmospheric oxygen. Also, the pathogenic organism and fly larvae are thoroughly destroyed. The composted mass may be converted into humus in a period of 15 to 20 days.

Mechanical compositing

In this method, the refuses are first cleared of solvable materials such as rags, bones, metal, glass and items which are likely to interfere with the grinding operation. It is then pulverized in order to reduce the size of particles to less than 40 mm. The pulverized reuse is then mixed with sewage in a rotating machine and incubated. The factors which are controlled in the operation are a certain carbon- nitrogen ratio, temperature, moisture, pH and aeration. The entire period of composting is completed in 4 to 6 weeks.

4.2.6 Energy from waste

Energy can be recovered from waste by various (very different) technologies. It is important that recyclable material is removed first and that energy is recovered from what remains, i.e. from the residual waste. This leaflet covers the following energy from waste (EfW) technologies:

- **Combustion**, in which the residual waste is burned at 850⁰ C and the energy recovered as electricity or heat.
- **Pyrolysis** and gasification, where the fuel is heated with little or no oxygen to produce “syngas” which can be used to generate energy or as a feedstock for producing methane, chemicals, bio fuels or hydrogen.
- **Anaerobic digestion** uses microorganisms to convert organic waste into a methane-rich biogas that can be combusted to generate electricity and heat or converted to bio methane. This technology is most suitable for wet organic wastes or food waste. The other output is a bio fertilizer.

Combustion

Combustion plants are often referred simply as EfW plants. They have a boiler to capture and convert the released heat into electricity and steam and extensive air pollution control systems that clean the combustion gases to comply with regulatory emission limits before they are released to atmosphere through a chimney. These plants typically use between 50 – 300 thousand tonnes per year of fuel.

Typical fuels

- Municipal Solid Waste (MSW)
- Commercial & Industrial Waste (C&I)
- Refuse derived fuel (RDF) or Solid Recovered Fuel (SRF)

Outputs

- Electricity or Heat – or both together if a Combined Heat and Power Plant (CHP)
- Bottom ash - This is what is left after combustion and it can be used as an aggregate or road bed material. If metal was not removed pre-combustion, it is recycled at this point.
- Fly ash - This is the material collected by the pollution control equipment.

Gasification & Pyrolysis

Sometimes referred to as ATTs (Advanced Thermal Treatments), gasification and pyrolysis plants thermally treat fuels without allowing enough oxygen for complete combustion. They are typically smaller and more flexible than combustion plants and typically consume between 25 and 150 thousand tonnes of waste per year, although some variations can consume up to 350 thousand tonnes per year.

Typical fuels

- Municipal Solid Waste (MSW)
- Commercial & Industrial Waste (C&I)
- Refuse derived fuel (RDF) or Solid Recovered Fuel (SRF)
- (non-waste fuels, e.g. wood / other forms of biomass)

Outputs

- Electricity or Heat – or both together if a Combined Heat and Power Plant (CHP)
- Syngas can be purified to produce “bio methane”, bio fuels, chemicals, or hydrogen
- Pyrolysis oils – these can be used to fuel engines, or turned into diesel substitute
- Feedstock’s for the chemical industry – allowing biomass to substitute for oil in the production of plastics for example
- Bottom ash, Char, or Slag – by-products which can be used for beneficial purposes such as aggregates or road bed material
- (Fly ash produced by some but not all plants)

Anaerobic Digestion (AD) / Biogas

Biogas/AD plants operate at low temperature, allowing microorganisms to work on the feedstock, turning it into biogas, which is a mixture of carbon dioxide and methane. They are typically much smaller than the combustion or gasification plants. A biogas plant is most appropriate for wet organic wastes such as food waste, sewage sludge, agricultural residues or energy crops.

Typical fuels

- Food wastes
- Some forms of industrial and commercial wastes, e.g. abattoir waste
- Agricultural materials and sewage sludge.

Outputs

- Biogas, which can be used to generate electricity and heat – CHP is the norm for such plants
- Biomethane for the gas grid, with the appropriate gas scrubbing and injection technologies
- Digestate - a material which can be used as a useful fertiliser / soil conditioner on agricultural land in lieu of chemical fertiliser

Review Questions

UNIT - IV

PART – A (Two Marks)

1. Write any two objects of sewage treatment.
2. What are the processes adopted in sewage treatment?
3. What is the purpose of providing screens?
4. Name any two types of Screens according to size of opening.(April 2011)
5. Name any two types of Screens according to shape.
6. What are the various primary treatment process?
7. Mention the secondary treatment units of sewage.
8. Define skimming Tank.
9. Where grit chambers are located?
10. Define grit chamber.
11. Write any two object of sedimentation tank.
12. What do you mean by sedimentation tank?\
13. Write any two types of sedimentation tank according to shape.
14. Mention any two types of filters.
15. Write any two advantages of trickling filter.
16. What do you mean by activated sludge?
17. Write any two properties of activated sludge.
18. Mention any two advantages of activated sludge process.
19. Define septic tank.
20. What is the function of septic tank?
21. Define solid waste.
22. Mention the types of solid wastes.
23. Define sludge. Mention its types.
24. Write any two necessities of solid waste disposal.
25. What do you mean by dumping of solid waste?
26. Differentiate reduction and reuse of solid waste. (Oct'2017)

PART – B (Three Marks)

1. What is grit chamber? Mention the purpose of grit chamber.
2. What are the advantages and disadvantages of contact beds?
3. What are the advantages and disadvantages of intermittent sand filter?
4. Write short notes on oxidation pond.
5. Mention the methods of sludge disposal.
6. Write about the collection and conveyance of solid waste.
7. Explain with example how energy is recovered from waste.
8. Write short notes on primary treatment.
9. Write short notes on secondary treatment.
10. Write about screens according to its conditions.
11. Write down the different methods of disposal of screens.
12. Explain the principles of sedimentation.
13. Distinguish between primary and secondary treatment of waste water. (Oct'2017)
14. Write short notes on energy waste from waste.(Oct'2017)

PART – C (Ten Marks)

1. Draw the schematic diagram of a sewage treatment plant and explain each Treatment unit briefly.
2. Explain briefly various types of screens used in sewage treatment.
3. Explain briefly the construction and operation of a primary clarifier.
4. Discuss briefly the construction and working of a standard rate trickling filter with a neat sketch.
5. What are trickling filters? Compare standard rate trickling filter and high rate Trickling filter.
6. What are the advantages and disadvantages of trickling filter?
7. Explain the working of skimming tank with neat sketch and state where it is commonly used.
8. Write short notes on
 - a. Soak pit
 - b. Dispersion trench
9. Write short notes on
 - a. Skimming tank

b. Dispersion trench

10. Explain briefly the construction details and working of a septic tank with a neat Sketch.
11. Explain briefly the disposal of septic tank with soak pits.
12. Explain with a flow diagram the treatment of Sullage water and write its advantages.
13. What do you mean by activated sludge? Explain in detail the activated sludge process. (Oct2017)
14. State the advantages and disadvantages of activated sludge of process.
15. Explain the construction and operation of oxidation pond.
16. Explain the different methods of sludge waste disposal.(Oct'2017)
17. Explain the various methods of solid waste disposal
18. Explain the process of reduction and reuse of solid waste.

www.binils.com

PART – III

UNIT – V

POLLUTION CONTROL

(5.1:Environmental – definition – water pollution – sources of water pollution – effects of water pollution – control of water pollution – soil pollution – sources of soil pollution – effects of soil pollution – control of soil pollution - noise pollution - sources of noise pollution –effects of noise pollution - control of noise pollution - air pollution – sources of air pollution – effects of air pollution on human beings, plants, animals, materials – air pollution control equipment – control devices for particulate contaminants – environmental degradation - ozone layer depletion Green house effect – Acid Rain)

5.1- ENVIRONMENTAL POLLUTION

5.1.1. General

The term environment is used to **mean the surroundings or region in which anything exists**. It is derived from an old French word environ meaning encircle. As far as pollution is concerned, it includes the air, the water, the soil, the noise, the building, the landscape, the oceans, the lakes, the parks, the vehicles and many other things.

5.1.2. Definitions:

Environment:

1. It can be defined in a number of ways
2. Sum of all social, biological and physical or chemical factors which compose the surrounding of man.
3. Environment is the representative of physical and chemical components of the earth wherein man is the important factor influencing the surroundings.
4. The sum of all living and non living factors makes the environment of an organism.

The **four major elements namely land, water, air and living organisms** together constitute what is known as environment or ecosystem. Environment can be further subdivided into

1. **Physical environment and**
2. **Organic or biological environment**

Environmentalist:

Environmentalist is a person who solves the environmental problems such as air, water, soil and noise pollution.

Pollution:

Pollution really originates from the human activities. If a pollutant is found to be potentially hazardous, its control should genuinely be attempted. A systematic pollution control would begin with “find an alternate” i.e., use of less polluting substance in place of highly polluting substance.

Pollution is **defined as the addition of the constituents to water, air or land, which adversely alter the natural quality of the environment.** Pollution is the unfavorable alteration of our environment largely because of human activities..

Pollution is injurious to health, therefore, pollution in any form is to be completely controlled. The aim of pollution control is to reduce the harms of a potential pollutant. This is a multi- step process.

5.1.3. Water pollution

Water is said to be polluted when it contains infective and parasitic agents, poisonous chemical substances, industrial or other wastes or sewage. Practically, all the water that appears in public or private supplies have been exposed to pollution.

Water, while falling as rain, while running over the ground surface or in streams, or while percolating through the soil gets polluted. Water pollution may be **natural or artificial.**

Natural pollution:

Natural pollution is **due to the impurities derived from the atmosphere, catchment area and the soil.**

Artificial pollution:

Artificial pollution is from the most serious aspect of water pollution. It is due to the introduction of the following wastes of water.

- Sewage, which contains decomposable organic matter and pathogenic agents.
- Industrial and trade wastes, which contain toxic agents ranging from metal salts to complex synthetic organic chemicals.
- Agricultural pollutants, which comprise fertilizer and pesticides.
- Physical pollutants viz. heat and radioactive substances. Most of the cities in India rely on river water for their needs. The chief drawback of river water is that it is always grossly polluted and is quite unfit for drinking. Nowadays, people everywhere are

becoming increasingly conscious of the hazards of water pollution. Therefore, it is necessary to control the degree of pollution of natural water bodies.

5.1.4 Sources of water pollution

There are two chief sources of water pollution

1. **Natural pollution**
2. **Artificial or manmade pollution.**

1. NATURAL POLLUTION

It is caused by the adverse weather conditions.

- Storm water bringing with it the surface wastes, silt, vegetable matter, mineral matter, bacteria, etc.
- Storage reservoir containing sand, silt, etc.
- Properties of ground surface through which water travels.
- Natural water pollution is occasional. Its consequential effects are little.

2. ARTIFICIAL POLLUTION

It is caused as the result of manmade activities.

- **Wastes from human habitation** such as human excreta, urine washing, kitchen and laundry wastes.
- **Wastes from industries** such as grease, oil, explosives, radioactive substances, chemicals alkalies, acids, lime starch highly odourous substances, coal washings, vegetable oil and soap, pulp-paper, etc.
- **Agricultural wastes** like barnyard drainage, washings of insecticides, pesticides, manure, etc.
- **Infiltration of surrounding substances** into the water distribution pipes through cracks or leaks joints.

5.1.5. EFFECTS OF WATER POLLUTION

Water pollution has the following adverse effects:

1. Polluted ground water is the major cause for the spread of epidemics and diseases in man. It causes **typhoid, jaundice, dysentery and diarrhea**.
2. Water contaminated by fibres causes fatal diseases like **lung cancer**.
3. Industrial effluents cause dietarian's effects on living organisms and may bring about **death and pathology of kidneys, liver, lungs, brain** and reproductive system.

4. Aquatic organism is adversely affected by a sudden change in pH conditions of river water.
5. Contaminated ground water **increases alkalinity in the soil.**
6. The protozoa, bacteria and virus may begin to grow on sewage under anaerobic conditions. This may cause or spread of water borne diseases like **polio, cholera, dysentery, typhoid, amoebia etc.**
7. The use of polluted ground water for irrigating agricultural field severely **damages crops and decreases grain production.**
8. Effluents containing acids and alkalies make the **water corrosive.**
9. High mineral constituents can be responsible for excessive hardness of water which then becomes **unsuitable for domestic and industrial purposes.**
10. Sulphate present in water, **causes intestinal problems.**
11. Acid pollution in water causes **damage to concrete structures** and water pipes due to their **corrosive reaction.**
12. Radioactive elements destroy biological immune systems, body becomes **less resistant towards a variety of diseases.**
13. River pollutant makes the water aesthetically **unfit for bathing** and other recreational purposes.
14. The **fish and other aquatic life are destroyed** due to de oxy generation.
15. In **sanitation is caused by suspended soil.**
16. **Evil smelling and unsightly sludge** is caused due to decomposed floating matter.

5.1.6. CONTROL OF WATER POLLUTION /PREVENTIVE MEASURES OF WATER POLLUTION

The following preventive steps may be taken to effectively control water pollution

1. The people **should be educated** to avoid water pollution.
2. All the wastes from industry and domestic must be **dumped with proper treatment.**
3. The industrial waste should be **treated well before discharging** them into natural water bodies.
4. Soil erosion must be prevented or controlled by proper **tree plantation.**
5. **Toxic and non-degradable materials** must be totally **banned.**
6. By **legislative control , rules and regulations** should be enforced for the preventive of water pollution.

7. **Scientific techniques** should be adopted for the environmental **control of catchment areas of streams and rivers**.
8. **Discharging any type of wastes**, treated or untreated, into natural water bodies **should be avoided**.
9. **Conservation of forest** is necessary as they act as natural air conditioners and control water pollution. In this regard, India has rightly raised the slogan, one family, one tree.
10. Developing **economic method of water treatment**.
11. Affluent **funds should be raised** for the construction and development of treatment plants for all kinds of wastes.
12. The **local authority and management** of various industries should jointly share the responsibility to **assure an effective water pollution control**.
13. **State and central** government should take **necessary steps** to prevent water pollution.
14. **Highly qualified persons** with rich experience should be utilized to **achieve effective water pollution control**.
15. Keeping in view the availability of water resources, **new towns, industrial plants and agricultural farms** should be **planned and located suitably**. So, rivers, streams, lakes and other water reservoirs must be well protected from being polluted.
16. **Continuous monitoring** of water pollution at different places is to be done.
17. **Recycling of water** must be encouraged.

5.1.7 SOIL POLLUTION

Soil pollution is defined as the **contamination of soil of a particular region**. Soil pollution is mainly due to the penetration of harmless pesticides and insecticides. One of the major pollution problems of large cities are the disposal of solid waste materials, crop residual, chemical, garbage, paper, plastics, rubber, cloth, leather, brick, metal, dead animals like cattle, dogs and birds.

5.1.8. SOURCES OF SOIL POLLUTION

The following are the main sources of soil pollution:

1. Chemical pollutant
2. Metallic pollutant
3. Industrial effluents

4. Pesticides
5. Radioactive pollutants
6. Agricultural wastes
7. Domestic effluents
8. Biological agents.

1. Chemical Pollutant

1. A number of industries textiles, pesticides, pharma, fertilizers, tanneries, batteries, petroleum, paper, sugar, steel, glass and metal industries pour their hazardous effluents in soil and water that has dangerous effects on living organism.
2. Salts and chemicals deposited on the upper layer make the soil harder and unfit for cultivation.
3. Toxic organic compounds and phenol destroy the fertility of the soil.
4. The chemicals retard the growth of plants and retard reproduction process.

2. Metallic Pollutants

1. Heavy metals like mercury, cadmium, lead are more toxic. Mercury compounds affect the nerves and brain.
2. Lead and cadmium cause abdominal pain, mental and nervous disorder.
3. Presence of high levels of Na, Mg, and K cause deficiency in soil.
4. The excess of sulphur is released in nature by chemical as sulphur dioxide.

3. Industrial effluents

Industries are the major causes for soil pollution nowadays. Textiles, steel, paper, pharma, chemical, cement, oil, dyeing and other industries are responsible for soil pollution.

4. Pesticides

1. Pesticides pollute soil. Pesticides are of two types.
 - a. **Chlorinated hydrocarbon insecticides**
 - b. **Organic phosphorus insecticides.**
2. The three most common chlorinated hydrocarbon insecticides are DDT, BHC, and cyclodine compounds.
3. The organic phosphorous insecticides are synthetic chemicals like Malathion, Parathion.
4. DDT reduces the activity of sex hormones of both male and female. The land consists of fungicides, insecticides, herbicides which create diseases to human beings.

5. Radioactive pollutants.

Atomic reactor and nuclear radioactive devices release the radioactive wastes enter the land and accumulate there creating land pollution.

Sr^{90} , Cs^{137} , Ba^{140} isotopes are very dangerous for man and animals. Some radioactive waste materials deposited to the land continuously emit gamma radiations which are harmful to plants, aquatic life and human beings.

6. Agricultural wastes.

Fertilizers discharge nitrogen, sodium, potassium, sulphate, nitrate, etc. in the soil. The nitrate creates diseases such as cancer. Cancer has been associated with nitrate through the formulation of N- nitrosamines and nitrosomides which are extremely powerful carcinogenic agents.

7. Domestic effluents

It has been found that the use of municipal waste water for irrigation purpose leads to substantial increase in accumulation of available Zn, Cu, Pb, and Cd in soil.

8. Biological Agents

The biological agents pollute soils. Lately, fungi, protozoa and bacteria are important biological agents for soil pollution. The human and animal wastes, garbage, waste water generate heavy soil pollution.

5.1.9 EFFECTS OF SOIL POLLUTION

1. Pollution runs off into rivers and **kills the fish, plants and other aquatic life.**
2. Crops and fodder grown on polluted soil **may pass the pollutants on to the consumers.**
3. **Crops and fodder may no longer grow** in polluted soil.
4. Toxic compounds **affect plant growth and human life** also.
5. Water logging and salinity **makes soil infertile.**
6. Hazardous chemicals enter into food chain from soil **disturbing the biochemical process.**
7. **Nervous disorders, gastro intestinal disorders, joint pain, respiratory problems** are the effects seen on human beings.

Effects seen on Human Beings.

S.No	Source	pollutants	Effects
1.	Nuclear reactors	Sr^{90} , I^{120} , Cs^{144} and other radioactive wastes.	Affects C,N,S brain and disorders of genetics.
2.	Industries	Toxic organic compounds, phenols, phosphorus, nitrogen	Spoil fertility of the land.
3.	Metallic Pollutants	Cu, Fe, Cd, Zn, Ni, Mn, Pb	Decrease the fertility of the soil.
4.	Agricultural wastes	Fungicides Hg, Co, Pb, Cd	Kidney, skin, lungs, diseases.
5.	Pesticides and fertilizers	DDT,BHC,Parathion	Skin, affect blood, kidney and heart.

5.1.10 CONTROL OF SOIL POLLUTION

- Soil erosion must be prevented or controlled by **proper tree** plantation.
- All the wastes from industry, domestic must be **dumped with proper treatment**.
- Use of synthetic fertilizers must be avoided. Instead **natural fertilizers must be preferred**.
- **Educate people** regarding the consequences of soil pollution and prevention soil pollution.
- Strict enforcement of **environment protection law**.
- **Toxic and non-degradable** materials must be **totally banned**.
- **Recycling and reuse of industrial** and domestic wastes can minimize soil pollution considerably.
- **Agricultural land** in the world is spoiled by soluble salts. In this case **modern scientific techniques** can be used to reduce salts flow to soil.
- In **Incineration and burning process**, **compact waste may be used as fuels**. This provides energy and also saves space.

5.1.11 NOISE POLLUTION

Noise Definition:

Noise is defined as “unwanted **sound**” or “**wrong sound**”, in the wrong place, at the wrong time. The noise is measured in terms of “**decibel**”- (**dB**).

Properties:

Noise has **two** important properties.

1. Loudness

2. Frequency

1. Loudness

It depends upon the amplitude of the vibrations which initiated the noise. The loudness of the noise is measured in decibel (dB). When we say that a sound is 60 dB, it means that it is 60 dB more intense than the smallest distinguishable noise.

Acceptable noise levels (dB).

Building Type	Room Details	Noise Level (dB).
Residential	Bed Room	25
Commercial	Living Room	40
	Office	35-45
	Conference	40-45
	Restaurance	40-60
Industrial	Workshop	40-60
	Laboratory	40-50
Educational	Class Room	30-40
	Library	35-45
Hospitals	Wards	20-30

2. Frequency

It is denoted as **hertz(Hz)**, One Hz is equal to **one wave per second**. The human ear can bear frequencies from about 20 to 20,000 Hz, but this range is reduced with age and other subjective factors. The range of vibrations below 20 Hz is infra-audible and those above 20,000 Hz are ultra-sonic. Many animals (e.gogs) can hear sounds inaudible to the human ear.

Sometimes noise is expressed in psycho-acoustic terms the phon. The phon is a psycho-acoustic index of loudness.

The base **instruments** used in studies on noise are

1. The **sound level meter** which measures the intensity of sound in dB or dB (A)
2. The “**octave band frequency analyzer**” which measures the noise in octave bands. The resulting plot shows the “sound spectrum” and indicates the characteristics of the noise, whether it is mainly high – pitched or of variably pitched.
3. The **audiometer** which measures the hearing ability. The zero line at the top in the audiogram represents normal hearing. Noise-induced hearing loss shows a characteristics dip in the curve at the 4000 Hz frequency.

5.1.12 SOURCES OF NOISE:

The sources of noise may be divided into the following groups.

1. Domestic Noise

It includes the operating of radio, television, record player, etc. with high volume. It may also include the use of vacuum cleaner for a long time.

2. Public Noise.

It includes the operation of loud speakers with high volume during the festivals, social functions, religious functions, etc.

3. Traffic Noise.

It includes the movements and horns of vehicle like buses, trucks, cars, etc. with high speed along the roads of the towns or cities.

4. Construction Noise.

It includes the sound created by the concrete mixer machine, mosaic polishing machine, vibrator, etc.

5. Industrial Noise.

It includes the sound created by stone crushing factory, glass factory, aluminum factory, motor garage, etc.

5.1.13 EFFECTS OF NOISE POLLUTION

Due to increase in population, number of vehicles and other sound articles, the noise is increasing day by day in the cities.

The following are the adverse effects of noise:

1. It decreases the efficiency of the worker.
2. The continuous noise of intensity 120 dB to 150 dB may cause permanent deafness.
3. The noise above 60 dB may cause nausea, headache, etc.
4. It may cause loss of sleep.
5. It may increase blood pressure.
6. It may cause irritation of mind.
7. It may cause digestive disorder.
8. It may develop hypertension.
9. Sudden loud noise may cause heart failure.
10. It increases strain in the nervous system of the people.
11. It may adversely affect the overall mental and physical health.

5.1.14 CONTROL OF NOISE POLLUTION

While noise cannot, of course be totally eliminated, efforts can be done to reduce it. The basic principles of noise control are :-

1. Control of noise at source

This may be achieved by segregating the noisy machines, application of mufflers or other noise reducers to the machine.

2. Control of transmission

This may be achieved by building enclosures and covering the room walls with sound absorbing materials.

3. Protection of exposed persons

Hearing protection is recommended for all workers who are consistently exposed to noise louder than 85 decibels in the frequency bands above 150 Hz. Workers from noisy areas must be regularly checked comparatively to quiet posts in factories. Periodical audiogram check-ups and use of ear plugs, ear muffs are also essential.

4. Legislation

Many states have adopted legislations provided for controls which are applicable to a wide variety of sources. Workers have the right to claim compensation if they have suffered a loss of ability to understand speech.

5. Education

No noise abatement programme can succeed without people's participation. Therefore, their education through all available media is needed to highlight the importance of noise as a community hazard.

5.1.15 AIR POLLUTION

Air pollution may be defined as “Addition of **harmful materials** into the air which alters its original nature and thereby air becomes unfit for all the living organisms existing on earth”.

So, the **accumulation of destructive elements** in the air from the natural or unnatural sources is termed as Air Pollution.

Air Pollution may also be defined as the **presence of one or more contaminants** like dust, smoke and odour in the atmosphere which are injurious to human beings, plants and animals.

The following are the causes of air pollution

1. Increase in population and traffic
2. Development of industries.
3. Development of automobile engineering
4. Development of agricultural.
5. Worldwide arms race.
6. Thermal and nuclear power generation.

5.1.16 SOURCES OF AIR POLLUTION:

Sources of air pollution may be classified into two groups

- **Natural Sources**
- **Man made sources**

1. Natural Sources:

Dust Storm:

Dust storms are produced due to wind circulation around the planet Earth. Global metrological processes make the environmental with dust pollution in some areas.

Forest Fire:

Huge quantities of smoke (Carbon particles) are liberated during forest fires.

Volcanoes:

Volcanoes (eruption of lava from earth's core) release lot of solid particles, gases like sulphur – di- oxide and radiation. Heat waves may be spread up to several kilometers.

The surrounding areas are greatly affected with heavy dust and heat pollution.

Sea Spray:

Sea spray is a continuous phenomena, which is a major source of particulate (liquid droplets) pollution in the atmosphere.

Plant Pollen:

During spring season, lot of plant pollen is produced and due to wind motion, it is spread very fastly, which makes the atmosphere with dust pollution. Many gaseous carbon compounds such as methane, carbon dioxide, carbon monoxide, etc are emitted into atmosphere through biological processes, volcanic eruptions, forest fires and natural gas seepage.

2. Man made sources

These may be classified into the following **four broad categories**.

- Industrial processes
- Combustion
- Motor vehicles
- Miscellaneous.

a. Industrial processes

In recent years, many types of industries such as chemical industries, metallurgical industries, oil refineries, fertilizer factories, etc. have sprung up. All these have contributed their might to air pollution.

b. Combustion

Industrial and domestic combustion of coal, oil and other fuels is another source of smoke, dust and sulphur-dioxide.

c. Motor vehicles

Motor vehicles are a major source of air pollution throughout the urban areas. Motor vehicles, ships, trains, air crafts and other forms of transports contribute to air pollution.

They emit hydro – carbons, carbon- monoxide, lead, nitrogen – oxides and particulate

matters. In strong sunlight, certain of these hydrocarbons and oxides of nitrogen may be converted into a photochemical pollutant of oxidizing nature. In addition, diesel engines, when misused or badly adjusted are capable of emitting black smoke and malodourous fumes.

d. Miscellaneous.

Burning of refuse, agricultural activities like crop spraying, pest control and nuclear energy programmes also contribute to air pollution.

5.1.17 Effects of Air Pollution:

Effects of air pollution are grouped as below.

- 1. Effects on human being**
- 2. Effects on animals**
- 3. Effects on plants**
- 4. Effects on materials**

1. Effects of air pollution on human beings

Air pollutants cause acute as well as chronic effect on human health. There is,

1. Irritation of the respiratory tract.
2. Irritation of eyes, nose and throat.
3. Lead Particles,(from automobile exhaust) cause lead poisoning in convulsion, delirium, coma and even death.
4. Cadmium particles (through cigarette smoking) cause cardio vascular disease, kidney and liver damage and even death.
5. Nickel particles (in tobacco smoke) result in respiratory damage.
6. Mercury (combustion of fossil fuels, plants) result in nerve, brain and kidney damage.
7. Radio-active fallout has some genetic effects on future generations

Table 5.1 Air Pollution Effect on Human Being

S. No	Pollutant	Health Effect
1	Lead	Bone troubles, liver and kidney damage, gastro intestinal damage, mental health effect in children and abnormalities in fertility and pregnancy.
2	Particulates and sulphur oxides	Severity of respiratory disease, chronic bronchitis and lung cancer.
3	Carbon mono oxide	It inhibits oxygen uptake of hemoglobin in the blood and is dangerous. Head ache and nousia..
4	Nitrogen compounds	Severely irritating and excess illness in all family.
5	Photochemical	Aggravation of asthma attacks and eye irrigation.
6	Ozone	Irritation of nose and throat, Headache and dryness of mouth and throat.

2. Effects of air pollution on animals:

1. Animals, particularly the farm animals, get poisoned when they eat contaminated vegetation.
2. Plants sprayed with insecticides containing arsenic can lead to the poisoning of cattle.
3. Pet animals are found to suffering from bronchitis, asthma and lack of appetite.

Table 5.2 Air pollution effect on animals

S. No	Pollutant	Effect on animal
1	Hydrogen sulphide	Respiratory, directory and pulmonary diseases.
2	Fog and smog	Respiratory track affected and lassitude
3	Ozone and photo chemical oxidants	Skin troubles, cancer and tumor on animals, ozone alone produce pulmonary troubles.
4	Fluoride (produces from cement zinc and aluminum industries.). It is also found in soil dust.	Pulmonary disturbances, decay of bones, diarrhea, loss of weight, loss in milk production, fertility and tooth of animals get affected.
5	Radio – active pollutants	Decrease the life span, genetic effect and blood cancer (leukemia)
6	Fluorine, arsenic, Lead	Affect livestock

3. Effects of air pollution on plants

The following are the effects of air pollution on plants :

1. Necrosis
 2. Chlorosis
 3. Leaves abscission
 4. Epinastly.
 5. Acute injury
 6. Chronic injury
- **Necrosis** is the death of internal cells of plants due to high concentration of pollutants of plants for short time.
 - **Chlorosis** is the loss of pigment causing colour due to low concentration of pollutants on plants for long time.
 - **Leaves abscissan** is falling down of leaves. This is due to necrosis and chlorosis.
 - **Epinastly** is the bending down of leaves. This is due to necrosis and chlorosis.
 - **Acute injury** is the severe visible damage to leaf tissues. It results due to short time exposure of pollutants of relatively high concentrations.
 - **Chronic injury** is the injury due to long term exposure of pollutants of low concentration

Table 5.3 Air pollution effect on plants.

S.no	Pollutant	Effect on plants
1.	Ozone	Affect the growth of tobacco plant.
2.	Ethylene	Affect orchide.
3.	Photochemical oxidants	A variety of tobacco is highly sensitive to this pollutant and get affected.
4.	Fluoride	Tobacco and gladiola plants are affected by fluoride.
5.	Smoke, smog, fog, etc	Affect forest
6	Sulphur – di – oxide	Even short time exposure give great damages to plants

4. Effects of air pollution on materials

Materials are affected by air pollutants in the following five ways.

1. Corrosion
2. Abrasion
3. Direct Chemical attack
4. Indirect chemical attack
5. Deposition and removal

These actions are added by temperature, moisture, wind, sunlight and position of materials.

Table 5.4 Air pollution effect on various materials

S.No	Materials	Pollutant	Effect on materials	Other aiding factors
1	Building Materials	SO ₂ acid, gases and adhering particulates	Discolorations	Moisture
2.	Metals	SO ₂ acid, gases	Tarnishing of surface, loss of metal	Moisture and temperature
3.	Paints	SO ₂ , H ₂ and particulates	Discoloration, inhibits dyeing	Moisture and fungus
4.	Ceramics	SO ₂ acid, gases	Discoloration material removal	Moisture
5.	Textiles	SO ₂ acid, gases air borne particulates	Dye-fading reduction in tensile strength, additional cleaning is necessary in laundry.	Moisture, sunlight and wind
6.	Paper	SO ₂ acid, gases	Embrittlement	Sunlight
7.	Rubber	Oxidants	Cracking	Sunlight
8.	Electric & electronic parts, microfilm	Air – borne ozone	Degradation	Wind

5.1.18. CONTROL OF AIR POLLUTION

The following are the **objectives of air pollution control**.

- Prevention of detrimental effect on public control.
- Protection of plant and animal life

- Protection of soiling and damage to property.
- Provision of visibility requirement for safe air and ground transportation.
- Maintenance of an aesthetically acceptable and enjoyable environment.

5.1.18.1 Prevention and control of air pollution.

The control of air pollution is ultimately an engineering problem. The World Health Organization (WHO -1968), in its publication research into environmental pollution recommended the following procedures for the prevention and control of air pollution.

2. Containment

The prevention of escape of toxic substances into the ambient air containment can be achieved by a variety of engineering methods such as enclosures, ventilation and air cleaning. A major contribution in this field is the development of arrestors for the removal of contaminants.

3. Replacement

Replacing the technological process causing air pollution by a new process that does not cause air pollution. Increased use of electricity and natural gas in place of coal is a new process of replacement.

4. Pollution dilution

It is dilution within the self-cleaning capacity of the environment. Some air pollutants are readily diluted by vegetation. The establishment of green belts between residential areas is a method of dilution. The dilution becomes very difficult when the atmosphere is over – burdened with pollutants.

5.1.19 AIR POLLUTION CONTROL EQUIPMENT

The following are the **common types of control equipment**

- Settling chamber
- Inertial separator (other than cyclones)
- Cyclones
- Electrostatic precipitators.
- Scrubbers (or) wet collectors.

5.1.19.1 CONTROL DEVICES FOR PARTICULATE CONTAMINANTS:-

Depending upon the collection efficiency, capacity and operation mode, the particulate collection equipments are divided into three types. They are

- A. Internal separator
- B. Wet collectors or scrubbers and
- C. Electrostatic precipitators.

A. Internal separator

Internal separators are manufactures in various shapes and sizes. The following are the most common types.

- 1. Gravity settling chambers
- 2. Cyclone filters
- 3. Fabric filters.

1. Gravity settling chambers

Gravity settling chamber mainly consists of an enclosed chamber as in fig. The velocity of the gaseous matter is considerably decreased. Thus, the dust particles settle down by gravity. In these chambers, the horizontal gas velocity should be kept as low as possible. The condition allows stream line flow and surely creates optimum settling conditions. Practically, the gas velocities are kept between 0.3 to 3 m/s in the chambers. Such velocities allow only large particles of size 40 micron and above to be removed effectively. The settling time required for smaller particles is very long. Therefore , the use of this type of equipment is impractical in such cases.

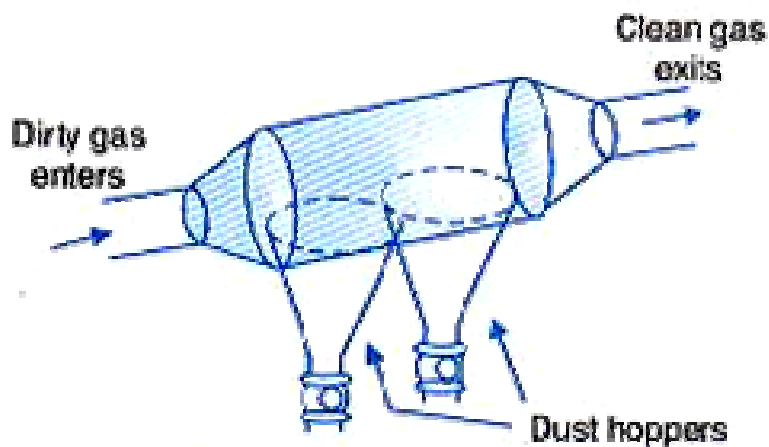

Fig. Gravity Settling Chamber

Advantages:

1. Simple in construction.
2. Low initial cost and low maintenance cost.
3. Dry and continuous disposal of solid particles is possible.
4. Low pressure drop.
5. Efficiency is high for coarse particle.
6. No moving parts involved.

Disadvantages:

1. Equipment may be subjected.
2. Low efficiency for particles of size range 5 to 10 microns.
3. Low efficiency for low concentration suspensions.

Application:

Settling chambers are used to remove particulates above 40 micron in diameter. They are used in

1. Food process industries
2. Metallurgical industries.

2. Cyclone filters

The cyclone filters works on the principle of separating the particles from the gas by transforming the inlet gas velocity into a double vortex motion inside the chamber. The entering gas spirals down at the inner surface of the cyclone. Then it spirals upward the central portion of the cyclone. This vortex separates the particulate matter which either falls down into the receiver or tends to concentrate on the surface of the cyclone wall. The clean gas then leaves the top portion of cyclone. These filters are cheaper in cost and best suited to dry dust particles of size 10 to 40 microns.

The efficiency of the cyclone filter increases with the increase of the following :

1. Inlet velocity of the dust laden gas.
2. Diameter of the dust particle.
3. Density of the dust particle.
4. Dust concentration in the carrier gas.
5. Smoothness of the inner cyclone wall.

If the quantity of gas treated is large, multi cyclone separators can be used. In this cyclone, the gas enters at the top and is given a twisting or vortex motion by a number of stationary vanes provided in its path. The efficiency is about 90 % for particulates of size 5 to 10 microns.

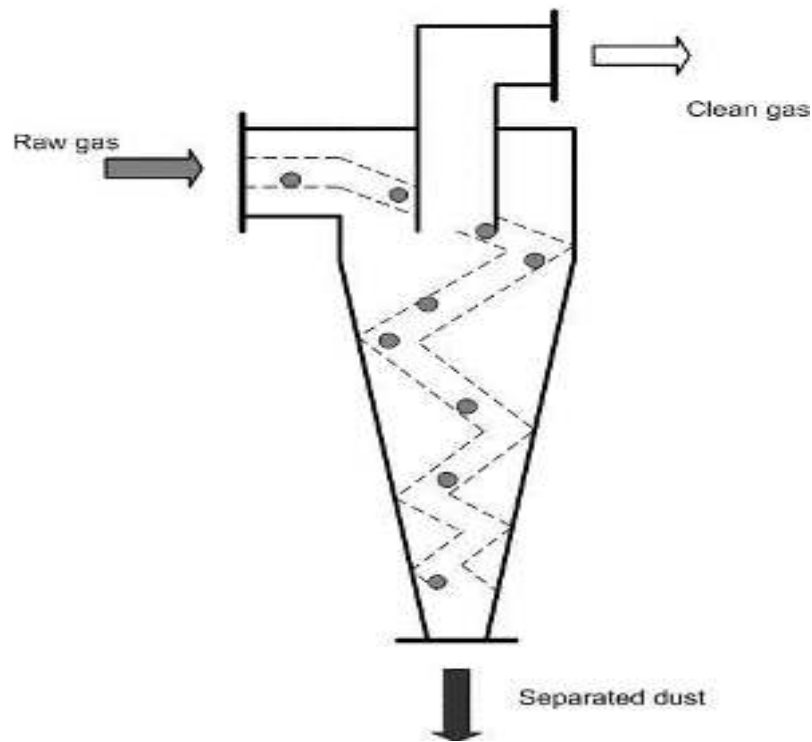

Fig. Cyclone Filter

Advantages:

www.binils.com

1. It is simple in construction and design.
2. Low initial cost and low maintenance cost.
3. No moving parts.
4. Pressure drop is less (25 mm to 200 mm)
5. It can be constructed with different types of materials to meet high temperature and pressure.
6. Dry and continuous disposal of solid particles is possible in the size range of 5 to 40 microns.

Disadvantages:

1. Equipment may be subjected to abrasion.
2. Low efficiency for particles of size range 5 to 10 microns.
3. Low efficiency for low concentration suspensions.

Application:

Cyclones are used to control the gas borne particulates. They are used in

1. Cement industry,
2. Grain processing,
3. Mineral processing, paper and
4. Textiles industries

3. Fabric filters. (Bag filters)

Bag filters are used for the removal of particles of size range of less than 10 microns. These are reliable and efficient system for particulate removals. These are arranged in an enclosure called as “**bag house**”. The size of each bag is 120 to 400 mm in diameter and 2 to 10 m long which are suspended. The outlet ends of the bags are open alternatively and attached to a manifold. The polluted gas enters through the inlet pipe. The large particles will fall into hopper by gravity. The gas flows into the bags and leaves through the outlet pipe. The particulate matter is retained on the inside of the bag and forms a cake. The cake will be cleaned with the help of the shaking mechanism, causing the filter cake to be loosened. The loosened cake will fall into the hopper which is provided at the bottom of the bag house.

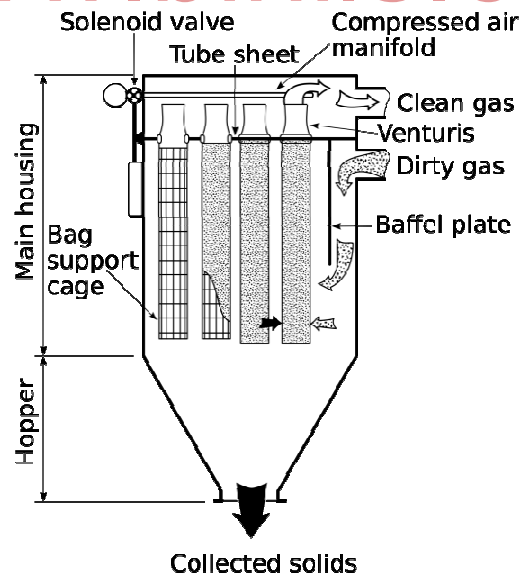

Fig. Fabric Filter

A wide variety of filter cloths are available commercially, which are given below.

Materials	Temperature range °C
Cotton (Cellulose Fiber)	80 - 85
Wool (animal fiber)	90 – 95
Nylon (Synthetic polyamide)	100-105
Darcon (poly ester fiber)	125 – 135
Fibre glass (Inorganic polymer)	250
Teflon	250

Advantages:

1. High collection efficiencies for all particle size.
Particles of even 0.01 microns can be effectively removed (high efficiency for small particles)
2. Disposal of collected materials is done in dry condition.
3. Nominal power consumption.
4. Simple construction and operation.

Disadvantages:

1. High pressure drop and high maintenance cost.
2. Clogging of filters takes place, hence required frequent cleaning.
3. Filters work up to moderate temperature.

Application:

1. Cement factory.
2. Brick industry.
3. Ceramic industry chalk and lime plants
4. Foundries.

B. Wet collectors or Scrubbers

The removal of dust particles from the gas streams is assisted by wetting the particles with liquid droplets or impinging the gas stream on a collecting surface.

Principle involved in collecting particles by wet scrubbers:

- **Movement**
The particles must move to the vicinity of the water droplets.
- **Collision**
The particle must collide with water droplets.
- **Adhesion**
It is promoted by the property of surface tension.
- **Precipitation**
Removal of the droplet containing the dust particle from gas phase.

The following are the **common wet collection devices**.

1. **Cyclone scrubbers or wet cyclones**
2. **Spray chambers**
3. **Venture scrubbers**
4. **Packed towers**

1. Cyclone scrubbers or wet cyclones

These are also known as wet cyclones. The principle of operation is exactly the same as that of dry cyclone. The difference being moisture conditions are prevalent inside the cylinder scrubber because of the water spray introduced at the entrance.

The efficiency of collection is more than the dry cyclone. These scrubbers are designed for an air velocity of 2000 litres/minute and the water requirement ranging from 10 to 50 litres for every 40 litres of gas treated. The particles removal efficiency is 90%.

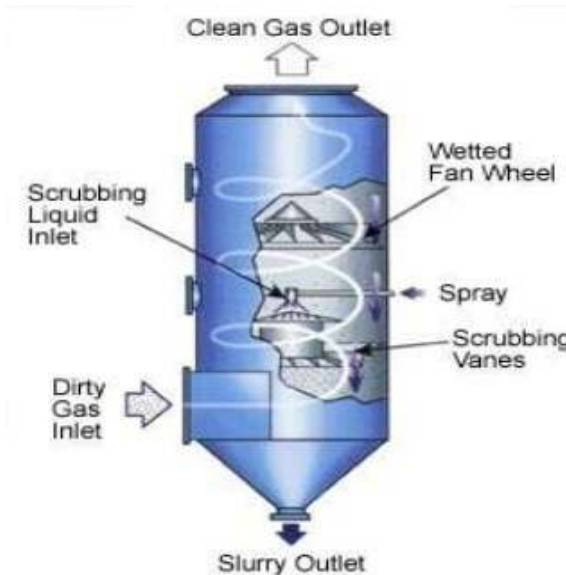

Fig. Cyclone Scrubber

2. Spray Chambers

This is a simple gravity settling chamber with liquid sprays. Here, the fine water spray washes the gas stream with water and settles the dust as sludge in the bottom of the chamber. The liquid droplets entangle the dust particles within them and fall down.,

Afterwards the dust particles are separated from the water by required sedimentation, flocculation, thickening and chemical treatments.

3. Venturi Scrubbers.

Venturi scrubber shown in Fig. can clean about 4000 litres of gas/minutes. To remove mist, usually the venturi scrubbers are followed by cyclonic separators. The gas is passed through the venturi portion at a very high velocity (3400 to 12600 m/minute). At the throat portion, water is introduced through the nozzle at 15 to 50 litres for every 40 litres of gas at very high velocity of the air stream. The water droplets are converted into fine sprays and droplets enclosed within itself. Smallest size particles fall down at the bottom of the separators. The efficiency is as high as 99%. It is suitable even for submicron range particles.

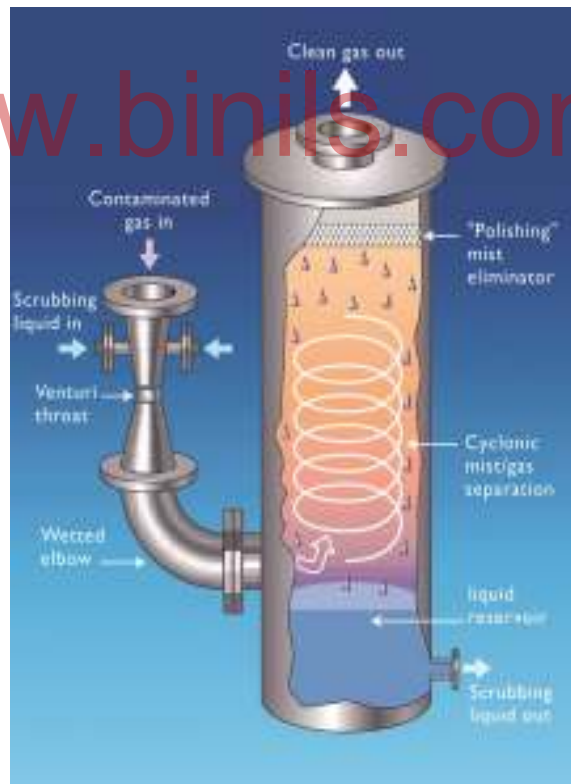

Fig. Venturi Scrubber

It is particularly suitable for very abrasive, corrosive and high temperature gases.

- The contaminated air enters the venturi and is accelerated in the converging section.
- The scrubbing liquid is introduced uniformly at the top of the converging section and it cascades by gravity and velocity towards the throat.
- The contaminated gas and scrubbing liquid enters the venturi throat where they are mixed at high energy and extreme turbulence.
- The scrubbed gas and the entrained droplets enter the diverging section where further collision takes place creating larger drops.
- The gas, then proceeds to the separator where the liquid droplets are easily removed and collected at the bottom, leaving the purified air to travel upward.

Advantages

1. Simultaneous gas absorption and particle removal.
2. Ability to cool and clean high temperature gas.
3. Efficiency can be varied.
4. Ability to collect high collection efficiency on fine particles.
5. Low initial cost.

Application

- 1) Iron and steel industry
- 2) Paper mills
- 3) Metallurgical furnaces

4. Packed Towers



Fig. Packed Tower

In a container, suitable packing materials are arranged (ceramic particles, coke, stone, etc). Through this obstruction, dust laden gas is passed from below upwards at a velocity of 18 to 20 litres/minute (for the fine packing) or 18 to 100 litres / minute (for coarse packing). From the opposite direction, water is allowed to pass through the bed. This water flow passing through the bed removes the dust particles retains in the bed. This water flow passing through the bed removes the dust particles retains in the beds. The quantity of water is so adjusted that all the dust particles are removed and settles down at the bottom of sludge.

C. Electrostatic precipitators (E.S.P)

Electrostatic precipitator (ESP) is a particulate collection device. They use electric energy directly to assist the removal of particulate matter. Advantages of this device are the removal of fine dusts from all kinds of waste gases.

General System Requirements:

- A source of high voltage
- Discharge and collecting electrodes
- Inlet and outlet for the gas
- Way for the disposal of collected materials (hopper)

Principle:

- Generation of electric field
- Generation of electric charge
- Transfer of electric charge on dust.
- Movement of charged particles in the electric field towards the collecting electrodes.
- Adhesion of particle on collecting electrode.
- Neutralise the charges of collector and dislodgement of particles.
- Collection

Types:

1) Pipe type

2) Plate type

Low voltage (40 to 60 kilovolts) precipitators are designed to handle $10 \text{ m}^3/\text{sec}$ with velocity 0.5 m/sec . High voltage (100 Kilovolts) precipitators are designed to handle huge volumes.

1) Pipe type precipitator

In this, the pipe is generally 300 mm in diameter (or) less. It acts as a collecting electrode. The discharge electrode is a wire. The gas flow is axial from bottom to top. Pipe electrode may be 2 to 3 m high.

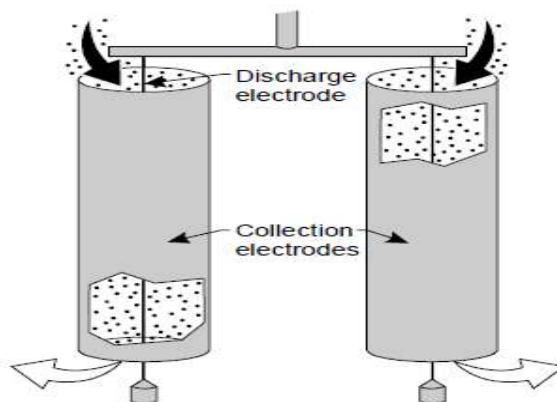

Fig. Pipe Type Precipitator

2) Plate type precipitator

In this type precipitator, the collecting electrodes consist of paneled plates. Discharge electrodes are wires or sometimes square rods of 4.8 mm are used. The wires are suspended midway between the parallel collecting electrodes and hung free, with a weight suspended at the bottom to keep them straight. Plants may be to 2 m wide and 3 to 6 m high. The dust material collected can be removed by rapping periodically or continuously. The efficiency of removal is 95 to 99%. The size of the particle removal is upto 0.1 micron.

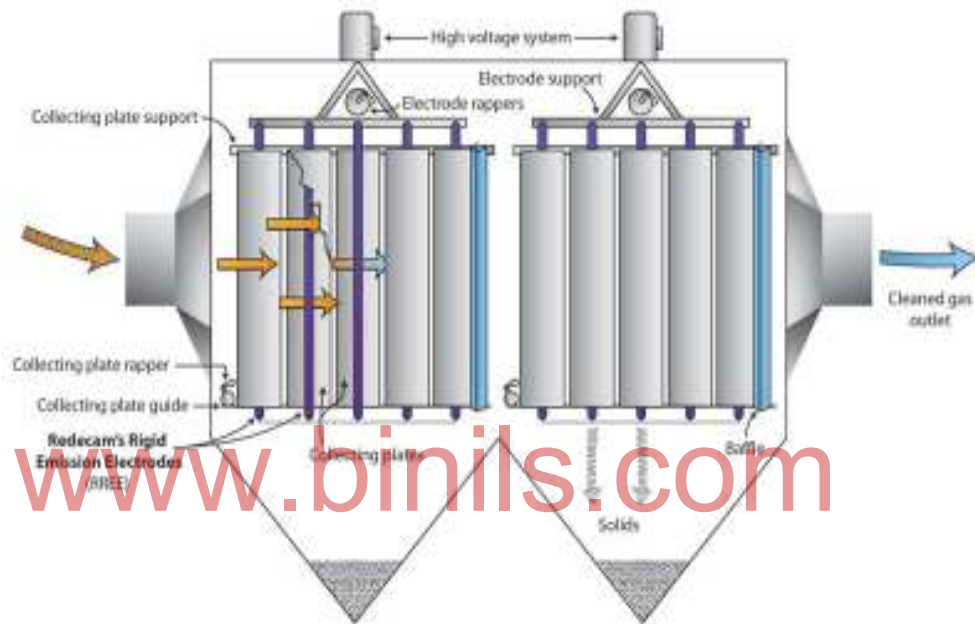

Fig. Plate Type Precipitator

Advantages

1. High collecting efficiency (up to 99 % obtainable)
2. Particulate removal up to 0.1 micron.
3. High gas holding capacity.
4. Low pressure drop.
5. Capable of operating at high temperature (upto 750°C)
6. Low Maintenance and operation cost.
7. Space for installation is less.
8. Treatment time is negligible (0.1 to 10 seconds)

Disadvantages:

1. High initial cost.

2. Skilled persons are required for operation.
3. Sensitive to variable dust loading
4. Possible explosion hazards.
5. Require pre cleaner like cyclones.

Application:

The important application of electro static precipitators in industries are

- Cement factories
- Pulp and paper mills
- Steel plants
- Chemical industries
- Petroleum industry.
- Thermal power plants.

5.1.20 ENVIRONMENTAL DEGRADATION:

Environmental degradation is the deterioration of the environment through depletion of resources such as air, water and soil.

Definition:

www.binils.com

It is defined as any **change or disturbance to the environment**. It is the **destruction of eco systems** and the extinction of wildlife.

Environmental changes are based on many factors including :

1. Urbanization
2. Population growth
3. Economic growth
4. Intensification of agriculture
5. Increase in energy use
6. Increase in transportation.

The following are the ways by which environmental degradation can be decreased.

1. By using recycled products
2. By conserving energy
3. By conducting awareness programmes
4. By conserving water

5.1.21. OZONE LAYER DEPLETION

Ozone layer:

Ozone layer is present in the atmosphere mainly in the stratosphere extending from 12 km to 35 km (maximum ozone at 25 km and above 50 km reduces to negligible). This upper layer of the atmosphere enveloped by ozone is known as **ozone layer**. Ozone concentration is 10 ppm in stratosphere and 0.5 ppm in the troposphere.

This layer is vital for life on the earth. It acts as a filter against the ultraviolet radiation. Ozone (O_3) is different from oxygen. The ozone is an unstable gas. It breaks down into O_2 and O and again it will form as O_3 with other O and O_2 .

5.1.21.1 DEPLETION OF OZONE LAYER

Ozone is produced naturally in the middle of upper stratosphere through the dissociation of molecular oxygen by sunlight. In the present day in stratosphere, this natural balance has been disturbed, mainly due to CFC, CH_4 , CO_2 , etc. Now, the concentration and thickness of ozone layer is reduced. This is known as depletion of ozone layer. It has been estimated that one molecule of chlorofluorocarbon can destroy 10000 molecule of ozone. A large area of intense ozone depletion over the Antarctic continent results in holes in ozone layer.

Effects of ozone layer depletion

- Damage immune system
- Disturbance in eco-system
- Increase of skin cancer
- Effect on crop result in reduction of crop yield.
- Shorter life of paints and plastics.
- Eye damage from cataracts including tumors of the conjunctive and cornea. Cataracts and retinal damage may be enhanced
- Acceleration of smog in cities
- Increase in heat absorption power than oxygen.
- Ultra violet causes Leukemia and breast cancer
- UV radiation makes the skin hot, swollen and red causing sun burns.

5.1.22 GREEN HOUSE EFFECT

Definition:

The progressive warming up of the earth's surface due to blanketing effect of man made green house gases in the atmosphere.

Green house gases include carbon dioxide, carbon mono oxide, methane, nitrous oxide, chlorofluorocarbons, ozone, and water vapour.

Green house is used to mean a building mainly made of glass, with heat and humidity regulated for growing plants.

The atmosphere is like a glass in a green house. Under normal concentration of CO₂, the temperature of the earth's surface is maintained by the energy balance of the sun rays. The rays that strike the plant and the heat is radiated back into the space. The atmosphere contains green house gases. These gas concentrations are increased by rapid industrialization and urbanization etc.

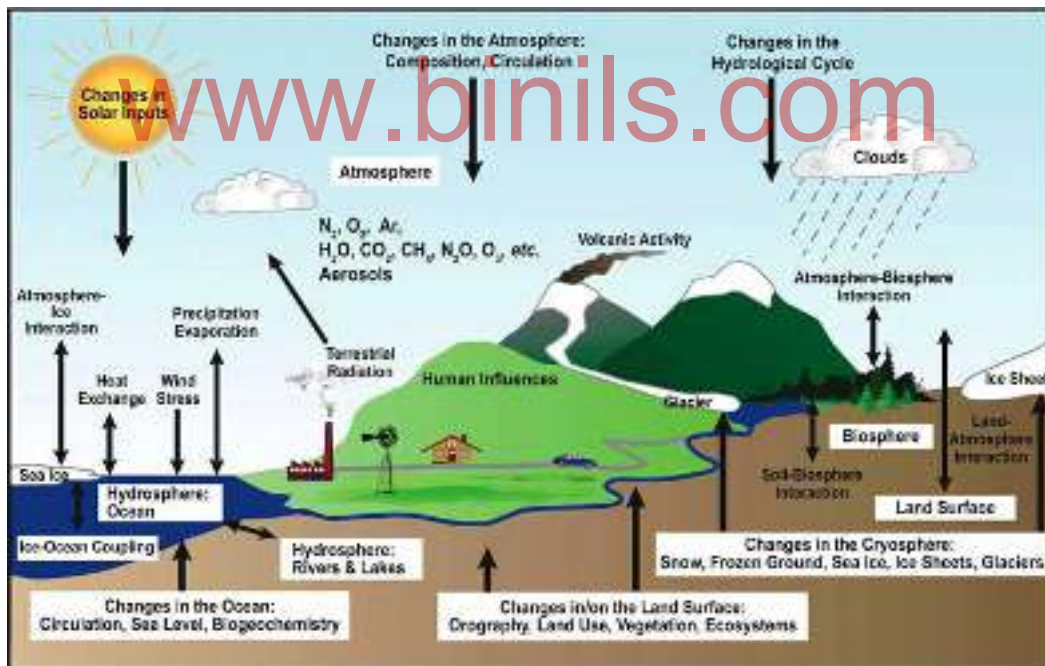

The thick envelop of this gas prevents the heat from being re-radiated out, resulting rise in the temperature of the earth. This phenomenon is known as green house effect. It is also called as Global warming.

5.1.22.1 Consequences of Green House effect

1. The Global temperature may be raised.
2. Climate changes may occur across countries.
3. Agriculture and livestock may be affected.
4. In sea, coral island and coral reef will die.
5. Forest and other natural ecosystems may be threatened.
6. Rise in sea level may flood agricultural lands in heavily populated coastal low lands.
7. Human settlement may be severely affected due to flooding, droughts, landslides and several wind storms.
8. There may increase in desert area.
9. In temperature region (like India) winter will be shorter and summer will be longer.
10. A slight increase in global temperature can adversely affect the world food production. Biological productivity also decreases due to warming of earth's surface layer.
11. Vector-borne and viral diseases may shift to higher latitudes, putting new population at risk.
12. The increased concentration of CO₂ results in more cyclones and hurricanes and leads to more floods during monsoon.

5.1.22.2 Remedial measures of Green House effect

1. Reducing the amount of energy used.
2. Increasing alternate energy sources.
3. Implementing forestation projects. Growing extra trees can slow the increase in net emissions by fixing carbon.
4. Countries should check their emissions of green house gases so that the cumulative addition of green house gases does not exceed a safe level.

5.1.23 ACID RAIN

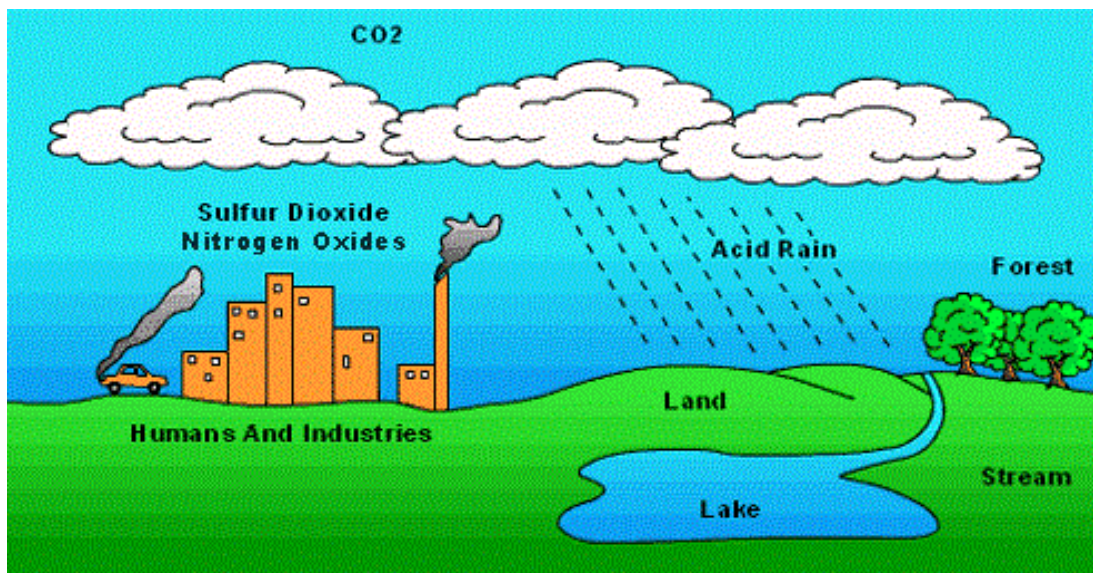

Acid rain is another type of air pollution which occurs when oxides of sulphur and nitrogen combine with moisture of atmosphere. i.e, it means the presence of excessive acids in rain water.

The sulphur di oxide and nitrogen oxide are released by the burning of fossil fuels like coal, petroleum and natural gas. It leads to the formation of sulphuric and nitric acids in air. They return to the ground by way of rain, snow, fog and as invisible dry forms. When it reaches earth, it can damage soil fertility, plant life, fresh water life in lakes etc.

The structure made by man also become victim of acid rain because it has the capacity of corrodes to corrode the hard surfaces. Air scrubbers and filters are fitted in the tall chimneys to control the pollution.

5.1.23.1 Effects of Acid Rain

1. Acidity affects soil.
2. It causes damage to leaves and accelerates leaf surface erosion.
3. It affects germination of seeds.
4. High acidity killing fish.
5. It affects the building materials.
6. It reuses growth and perhaps reproductive failure.
7. It affects human nervous system, respiratory system and digestive system.

Some of the historical monuments which are being **attacked by acid precipitation in India** are

- Tajmahal in Agra.
- Jama masjid in Delhi.
- Red fort in Delhi.
- Qutabminar in Delhi.
- GolGumbaz in Bijapur.
- Victoria memorial in Calcutta.
- Konark Temple in Orissa.
- Ellora caves in Aurangabad.

www.binils.com

5.2 ENVIRONMENTAL IMPACT ASSESMENT

(5.2: Environmental impact assessment (EIA) – methodology of EIA –organising the job – performing the assignment – preparation of environmental impact statement (EIS) – review of EIS – environmental risk assessment – limitation of EIA.)

5.2.1 General

The **Environmental impact assessment (EIA)** serves one or more of the purposes such as decision making, choosing among various alternatives and integrating environmental cost into project cost.

Objective

The main objective of EIA is to ensure the development to sustained with minimal environmental degradation.

Definition

- EIA can be defined as a study of the effects of a proposed project, plan or program on the environment.
- EIA is a process of identifying, predicting, evaluating and mitigating the bio- physical, social and other relevant effects of development proposals prior to major decisions being taken and commitments made.

EIA is a **valuable decision making tool** in following areas.

1. Alternate routes of development.
2. Alternate project sites.
3. Alternate process technology.
4. Quality of environment before, during and after the proposed developmental activity.

Purpose

The purpose of EIA is to help design projects.

Goal

The Goals of Environmental impact assessment are

1. Resource conservation
2. Waste minimization.
3. Recovery of by product.
4. Efficient equipment usage.

5.2.2 METHODOLOGY OF EIA

The process of EIA involves the major elements of identification, measurement, interpretation and communication of impact. A number of techniques have been developed for presentation of these impact results to decision makers and general public. These techniques include

- (i) **Adhoc method**
- (ii) **Overlays method**
- (iii) **Impact checklists**
- (iv) **Matrix method**
- (v) **Network methods**

(i) **Adhoc method**

- In the industrial locality, the experts review and identify the problem.
- In their observations reported, their observations are not usually based on any detailed investigations.
- They may not also go into various alternatives and remedies available in a systematic and comprehensive method.
- But this report may be considered initially useful in the preliminary evaluation of project set-up from the environmental considerations.
- This method provides minimal guidance for total impact assessment.
- In this method, the total impact of a project is considered and the nature of the impact upon it, such as no effect, problematic, short or long term and reversible or irreversible are identified.

Generalized EIA Process Flow chart

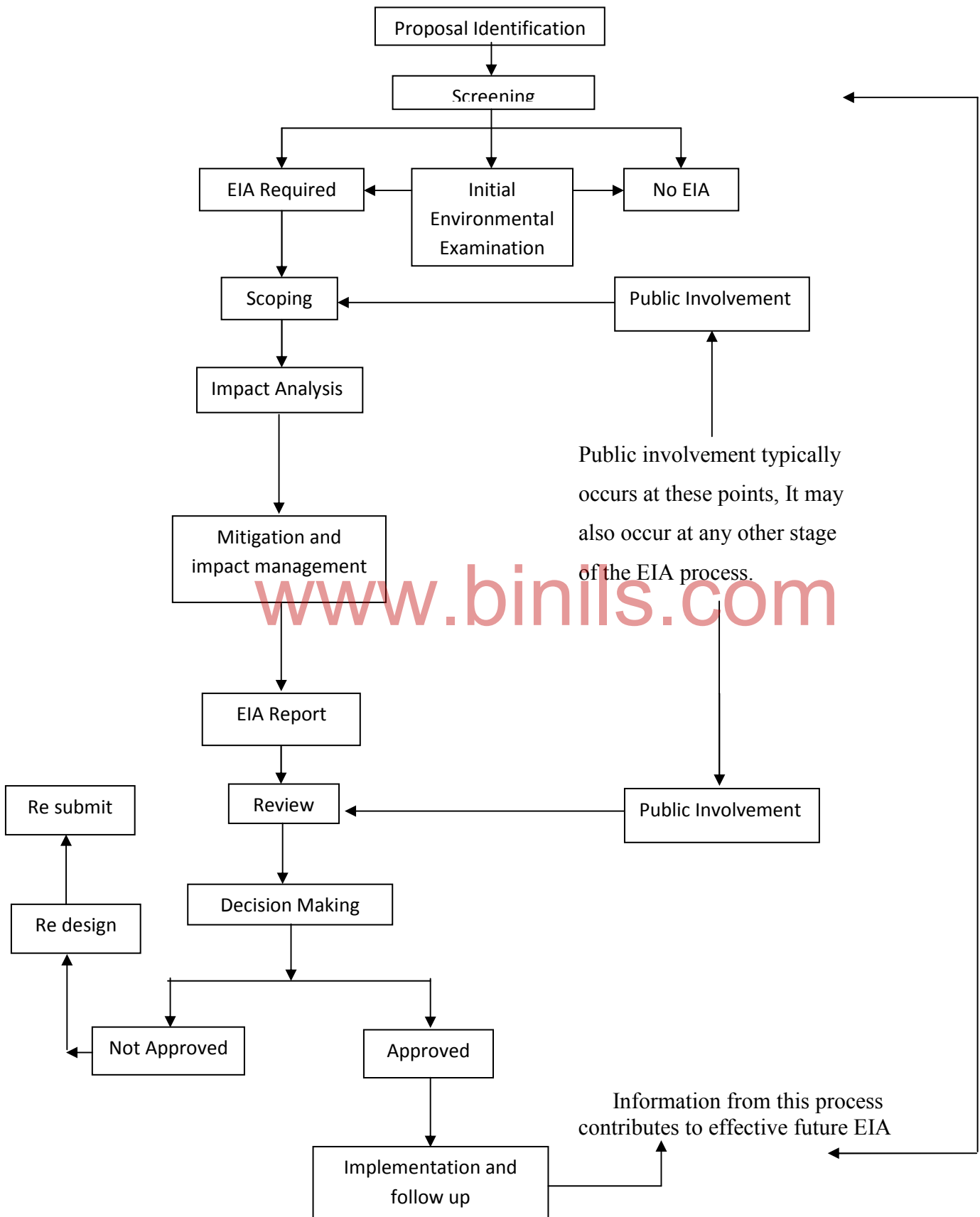

(ii) Overlays method

- Overlays method generally rely on a set of maps of project area's environmental characteristics.
- These maps are over laid to produce a composite characterization of the area's environment.
- Impacts are then identified by noting the environmental changes within the project or boundaries.
- This method is sometimes referred to as the McHarg method.

(iii) Impact checklists

- In this method, a list of potential impact areas that are needed to be noted in the EIA process are combined with an assessment of the individual impacts.
- This approach can be adopted by a number of public agencies.

(iv) Matrix method

- This method incorporates a list of projects, activities or actions with a checklist of environmental conditions or characteristics that might be affected.
- These lists are combined as horizontal and vertical axes for a matrix and the cause effect relationship between specific activities and impacts are identified.

(v) Network methods

In this method, a list of project activities or actions are selected and the cause – condition-effect networks are generated.

- This method provides a road map type of approach to the idea identification of second and third order effects.
- The idea is to start with a project activity and identify the types of impacts which would initially occur.
- The next step is to select each impact and identify the impacts which may be induced as a result.
- This process is repeated until all possible impacts have been identified.

EIA can identify major areas of environmental damage due to developmental activities in systematic and comprehensive manner.

EIA Consists of four phases.

- 1. Organising the job**
- 2. Performing the assessment**
- 3. Writing the environmental impact statement (EIS)**
- 4. Review of EIS.**

The environmental impact assessment process is described with the aid of a chart.

ENVIRONMENTAL IMPACT ASSESSMENT PROCESS

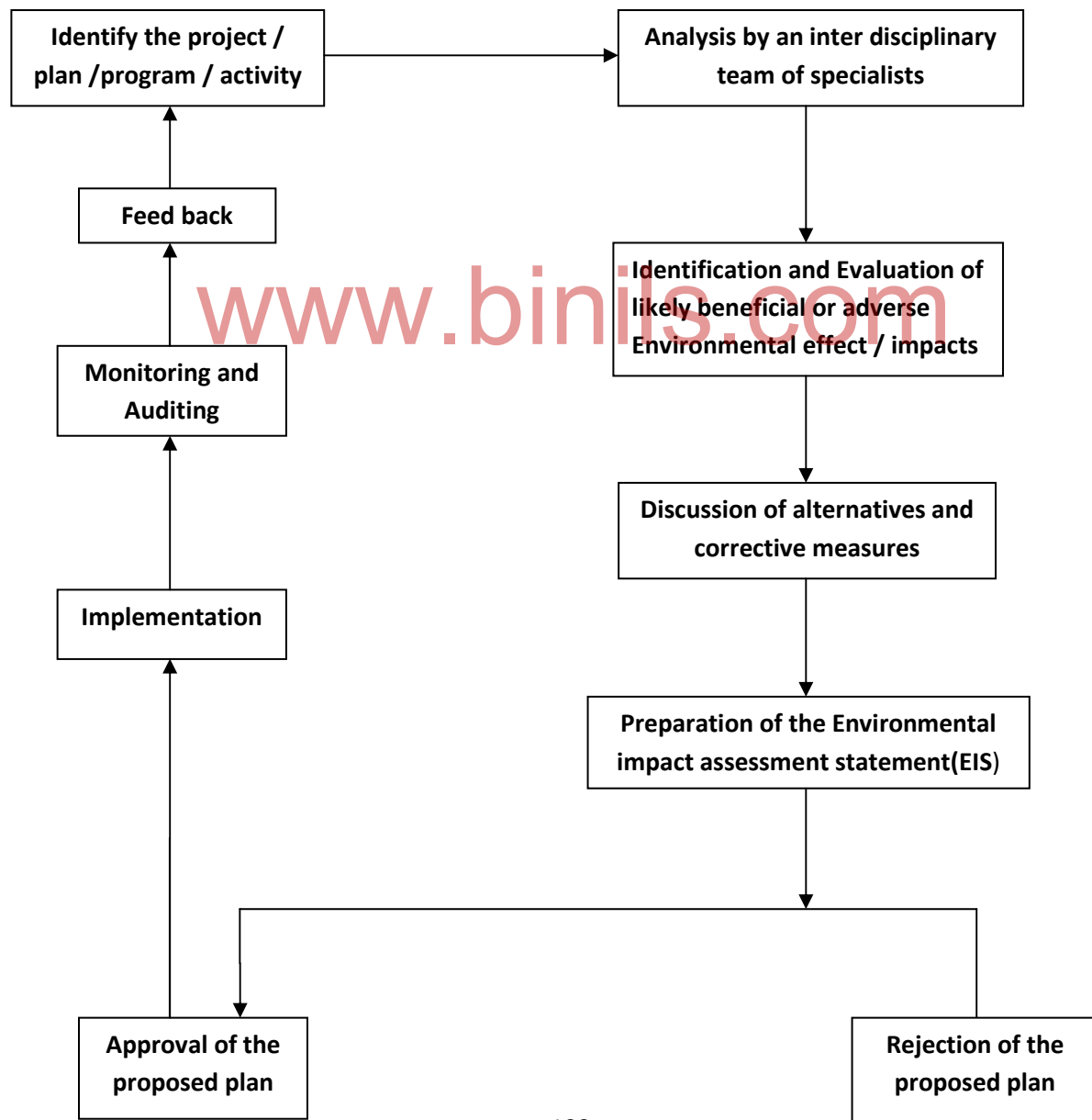

1.2.3 ORGANISING THE JOB

In this, the action is identified first. Then an interdisciplinary (ID) team is constituted to conduct the analysis. For the success of the analysis, an appropriate specialist in the interdisciplinary team (Geologists, Ogronomists, Hydrologists, Meteorologists, Biologists, Cultural scientists, etc) is included.

A time frame to conduct the analysis and knowledge of the relevant rules, regulations and limitations on the part of government are necessary. Finally a form is prepared to document the particulars concerning the project, the participants of the ID team, activities, responsibilities, time frame, cost estimate etc. This form is distributed to each member of the ID team.

5.2.4 PERFORMING THE ASSESSMENT

The following are the four steps of environmental impact assessment.

- A site visit by the inter-disciplinary team to determine the possible environmental impacts of the proposed project. They record the description of the environment as it exists prior to the proposed action.
- Identification and evaluation of the likely beneficial or adverse environmental effects of the proposed project.
- Discussion of alternatives.
- Preparation of check list for EIA.

5.2.5 PREPARATION OF ENVIRONMENTAL IMPACT STATEMENT (EIS)

The final EIA report is referred to as an Environmental Impact Statement (EIS). Ideally, the content of an EIS should have the following.

- Description of the site (or) environment where the proposed project is to take place.- (Executive summary)
- Description of the proposed project. It means the objectives and goals, magnitude, area, extent, equipments, man power and material requirements.
- The environmental impact of the proposed project (i.e on air, water land, ecology, sound, socio-economics).
- The industrial activity resulting unavoidable adverse.
- Alternate of the activity.

- Relationship of the proposed activity to the existing land use plan.
- Relationship between the local short term uses and long term productivity of the resources involved.
- Identifying the measures that can be taken in order to minimize the adverse effects.
- Appendices including
 1. Reference documents, photographs, un published data.
 2. Terms of reference
 3. Consulting team composition
 4. Notes of public consultation sessions.

The EIS should be written in a clear and comprehensive manner. It should be presented to component authority, public and independent experts. Then it is reviewed carefully before any decision is taken in favor or against passing the proposed project.

5.2.6 REVIEW OF EIS

After it has been written, the EIS is presented to the public for public participation. The EIS is presented to the public to make the role of public participation more effective in developmental planning progress

Public Participation is important to maintain safe and healthy environment. To upgrade the standard of living, advanced technology may be utilized without exploiting the environment.

The proposed project is made available for public inspection by publicity through the press This results in a discussion session of the government agency and the public, provides the opportunity for obtaining further information and comments from the public and component authorities.

The period of at least one month is given for public inspection and submission of comments to the EIS for final decision comments of the competent authority.

After the final review of beneficial and adverse environmental impact and cost benefit analysis etc., a decision is ultimately taken to either select or reject the project.

5.2.7 ENVIRONMENTAL RISK ASSESSMENT (ERA)

Risk assessment provides a systematic procedure for predicting potential risks to human health or the environment.

An Environmental Risk Assessment (ERA) is a process of predicting whether there may be a risk of adverse effects on the environment caused by a chemical substance.

Environmental exposure concentration of a chemical is predicted and compared to no effect concentration for different environmental compartments.

ERA can also reveal if measures are needed to limit the potential environmental consequences of a substance.

Eg. In a certain application, it can point out if further testing and knowledge about a substance is needed.

5.2.8 LIMITATION OF EIA

To maintain the quality environment EIA is the major instrument.

Limitations:

1. EIA is undertaken at the project level whereas it should be done at the policy and planning level.
2. If the EIA is implemented at the level of district planning, it helps to the local environment.
3. There is no criteria to decide what type and scale of projects are to undergo EIA.
4. Lack of comprehensive environmental information base, limitations of time, manpower, financial resources etc., make EIA very difficult to handle.
5. More research and development of improved methodologies is required to overcome limitations relating to the uncertainties in data.
6. The EIA reports are difficult for a common man to understand.
7. In practice, EIA ends immediately of the project clearance due to lack of compliance monitoring.
8. Lack of public acceptance of EIA.
9. EIA, as it is practiced at present is an art and not a science.
10. One of the conceptual limitations of EIA is that it does not incorporate the strategies of preventive environmental intervention.

Review Questions

UNIT - V

PART – A (Two Marks)

1. Define the term Environment.
2. State the types of pollution in environment.
3. Define the term water pollution.
4. Mention the sources of water pollution.
5. State any five points to prevent water pollution.
6. List out the industries producing harmful waste water.
7. Define the term Land or soil pollution.
8. Write the sources of soil pollution.
9. State any two effects of soil pollution.
10. What are the sources of noise pollution?
11. Define air pollution.
12. What are the sources of air pollution?
13. Write any two air pollution control equipments.
14. What is meant by Ozone layer depletion?
15. Define the term Green house effect? (Oct '2017)
16. Write any two consequences of Green house effect.
17. List any four green house gases.
18. Define acid rain.
19. What do you mean by EIA?
20. State any two limitations of EIA.
21. Define EIS.
22. Expand : EIA and EIS.

PART –B (Three Marks)

1. What are the effects of noise pollution?
2. Mention the equipments used to control air pollution.
3. What are the consequences of Ozone layer depletion?
4. Write about manmade sources of air pollution.
5. Write the consequence of Green house effect.

6. Explain green house effect
7. Write the consequences of acid rain.
8. Explain the term ozone layer depletion and acid rain. (Oct'2017)

PART – C (Ten Marks)

1. Explain in detail about the causes and effects of water pollution.
2. What are the measures to be taken to prevent water pollution?
3. Explain in detail the causes, effects and preventive measures of soil pollution.
4. Explain briefly the prevention of land pollution.
5. Write short notes on
 - (i) Acid Rain
 - (ii) Ozone depletion
6. Explain the effects of air pollution on humans, animals, plants and materials.
7. What are the air pollution control equipments? Explain with neat sketches. (Oct '2017)
8. Explain briefly about Green House effect and depletion of Ozone Layer.
9. State the limitations of EIA.
10. Explain how the Environmental Impact Statement is prepared?
11. Explain the different methodology of EIA.(Oct'2017)

www.binils.com