

**GOVERNMENT OF TAMILNADU  
DIRECTORATE OF TECHNICAL EDUCATION  
CHENNAI – 600 025**

**STATE PROJECT COORDINATION UNIT  
Diploma in Electronics and Communication Engineering**

**Course Code: 1040**

**M – Scheme  
e-TEXTBOOK**

**on  
ELECTRONIC DEVICES AND CIRCUITS  
for  
III Semester DECE**

**Convenor for ECE Discipline:**

\_\_\_\_\_

**Dr.M.Jeganmohan M.E.,MBA.,Ph.D.,(Management),Ph.D.,(Engineering),M.I.S.T.E.,**  
Principal,  
Government Polytechnic College,  
Uthapanaickanoor,  
Usilampatti – 625 536.

**Team Members for Electronic Devices and Circuits:**

**Mrs.A.S.Venkatramani B.E., M.Tech.,**  
HOD (i/c)/ECE,  
226, P.A.C.Ramasamy Raja Polytechnic College,  
Rajapalayam - 626108.

**Mr.A.Balachandran M.E., PGDCA.,**  
Lecturer(Selection Grade)/ECE,  
215, Sakthi Polytechnic College,  
Erode - 638315.

**Mr.M.Muthukrishnan B.E.,**  
Lecturer/EEE,  
226, P.A.C.Ramasamy Raja Polytechnic College,  
Rajapalayam - 626108.

**Validated By**

**Dr.Vijayakumar M.E., Ph.D.,**  
Assistant Professor,  
Anna University Campus,  
Coimbatore - 641047.

# CONTENTS

UNIT NO	UNIT NAME	PAGE NO
UNIT – I	SEMICONDUCTOR AND DIODES	(4-18)
UNIT – II	BIPOLAR JUNCTION TRANSISTOR	(19-45)
UNIT – III	TRANSISTOR OSCILLATORS AND FET AND UJT	(46-62)
UNIT – IV	SCR, DIAC, TRIAC & MOSFET	(63-75)
UNIT – V	OPTO ELECTRONICS DEIVES AND WAVE SHAPING CIRCUITS	(76-88)

[www.binils.com](http://www.binils.com)

## SYLLABUS

### UNIT – I: Semiconductor and Diodes:

**Semiconductor**-Definition, classification, intrinsic and extrinsic N type & p type – drift current & diffusion current diodes – PN junction diode – forward and Reverse bias characteristics – specification – zener diode construction & working Principle-characteristics - zener break down-avalanche break down-zener Diode as a voltage regulator –applications- specifications

**Rectifier** – introduction-classification of rectifiers-half wave rectifier-full wave Rectifier(center tapped, bridge)-(no mathematical equations)-comparison- Applications-filters-C, LC and PI filters

### UNIT – II: Bipolar junction Transistor:

**Transistor** – NPN and PNP transistor – operation-transistor as an amplifier- transistor as a switch – transistor biasing – fixed bias, collector base bias, self bias – CB,CE,CC configurations – characteristics - comparison between three configurations in terms of input impedance, output impedance, current gain, voltage gain – classification of amplifiers- RC coupled amplifier – emitter follower and its application – negative feedback Concept, effect of negative feedback – types of negative feedback connections

### UNIT – III: Transistor Oscillators and FET and UJT:

**Transistor oscillator** – Classifications – Condition for oscillations (Barkhausen criterion) – General form of LC oscillator – Hartley Oscillator – Colpitts Oscillator – RC Phase shift oscillator- Crystal oscillator.

**Field Effect Transistor** – construction – working principle of FET – difference Between FET and BJT – classification of FET – characteristics of FET – Applications – FET amplifier (common source amplifier).

**Uni Junction Transistor** – construction – equivalent circuit – operation – Characteristics – UJT as a relaxation oscillator

### UNIT – IV: SCR, DIAC, TRIAC & MOSFET:

SCR – introduction – working – VI-characteristics -comparison between SCR and transistor – SCR as a switch, controlled rectifier. TRIAC working principle, Characteristics – DIAC – characteristics – DIAC as bi- directional switch. MOSFET – types & characteristics of N channel MOSFET and P channel MOSFET- Characteristics of enhancement and depletion mode MOSFET – MOSFET as a switch. Applications of SCR, TRIAC, DIAC and MOSFET.

### UNIT – V: Opto Electronics Devices and wave shaping circuits:

Classification of opto electronic devices – symbols, Characteristics, working of LDR, LED, 7 segment LED and LCD– opto coupler - Photo transistor. Clipper, Clamper Circuits and waveforms only – Solar Cell - Principles -Applications. Astable, Monostable and Bi-stable Multivibrators using Transistors - Schmitt Trigger using Transistors.

# UNIT - I

## SEMICONDUCTOR AND DIODES

### Introduction:

### Atomic theory

#### Atom:

It is the smallest particle of an element. It consists of positively charged protons, negatively charged electrons and neutral neutrons. The central part which consists of protons and neutrons is called nucleus. Electrons revolve around nucleus in various orbits. The maximum number of electrons in each orbit is limited by the formula  $2n^2$ .

#### Valence electrons:

The electrons in the last orbit are called valence electrons.

#### Free electrons:

The valence electrons which are loosely connected with the nucleus are called free electrons. They can move from atom to other.

#### Bounded electrons:

The electrons which are tightly attached with nucleus are called bounded electrons. They are the innermost orbit electrons.

### Atomic structure of Silicon & Germanium

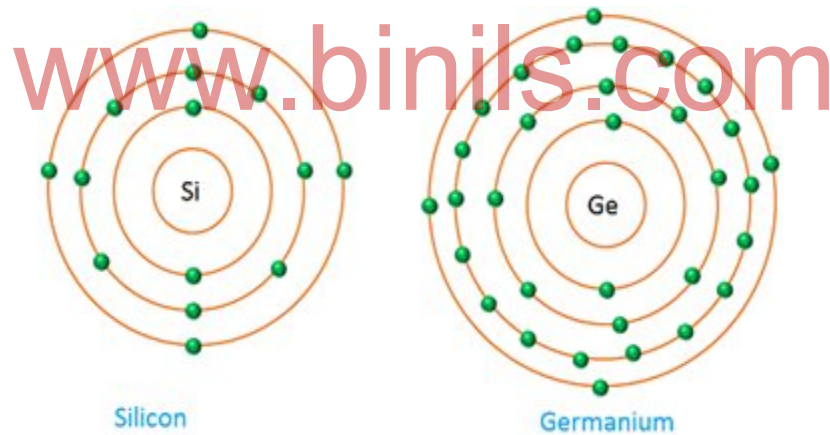

#### Silicon:

Its atomic number is 14. It consists of 14 protons & 14 electrons. The 1<sup>st</sup> orbit consists of 2 electrons. The 2<sup>nd</sup> orbit has 8 electrons. The 3<sup>rd</sup> has 4 electrons. The valence number is 4.

#### Germanium

Its atomic number is 32. It consists of 32 protons & 32 electrons. The 1<sup>st</sup> orbit consists of 2 electrons. The 2<sup>nd</sup> orbit has 8 electrons. The 3<sup>rd</sup> has 18 electrons. The 4<sup>th</sup> has 4 electrons. The valence number is 4. These elements are called semiconductors.

## Energy Band diagrams

The electrons moving in a particular orbit possess energy. The energies possessed by the electrons of the same orbit are not equal. The range of energies possessed by the electrons of the same orbit is called as energy band of that orbit.

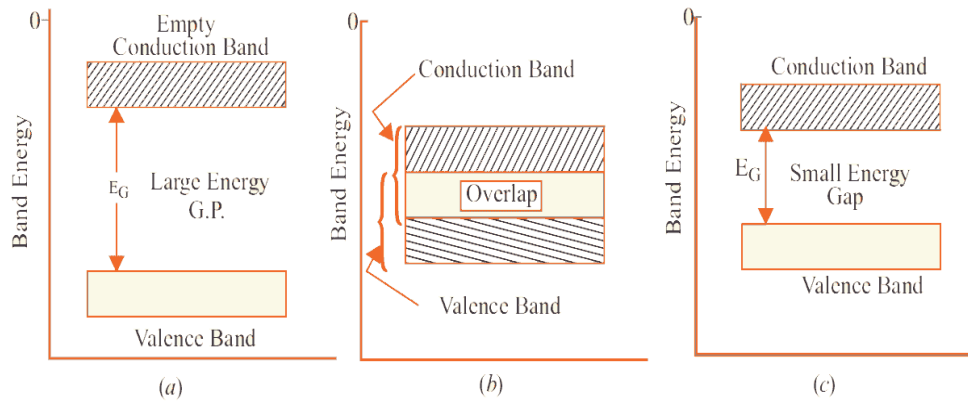

### Valance band:

It is the highest occupied energy band. It represents the range of energies possessed by valence electrons. The band may be completely or partially filled in.

### Conduction band:

It represents the range of energies possessed by free electrons. These electrons move freely and conduct electric current. This band may be empty or partially filled in.

### Forbidden energy gap:

The energy gap between the valence and conduction bands is called forbidden energy gap. There is no allowed energy state in this region. This gap indicates the amount of energy needed to push an electron from valence band to conduction band. It is represented by electron-volt (e-v).

### SEMICONDUCTORS:

It has conductivity much greater than that of an insulator and much smaller than that of conductor. At low temperature the valence band remains full and the conduction band is empty. So it acts as an insulator. The forbidden energy gap is very small about 1eV. By giving minimum external energy, the valence electrons move into conduction band. So the conductivity increases. It has negative temperature coefficient of resistance i.e. when the temperature increases, the resistance decreases.

### Note:

- When the number of valence electrons = 4, the element is semiconductor.
- When the number of valence electrons >4, the element is an insulator.
- When the number of valence electrons <4, the element is a conductor.

## Bonding in semiconductors:

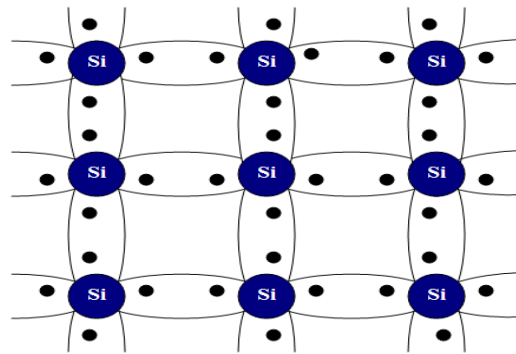

In semiconductors, to have atomic stability, co-valent bonds are formed. The semiconductor has 4 valence electrons. So each atom is forced to make bonding with other atoms. Bonds are formed by sharing valence electrons in such a way that each orbit gets 8 electrons.

## Electron – Hole pair generation:

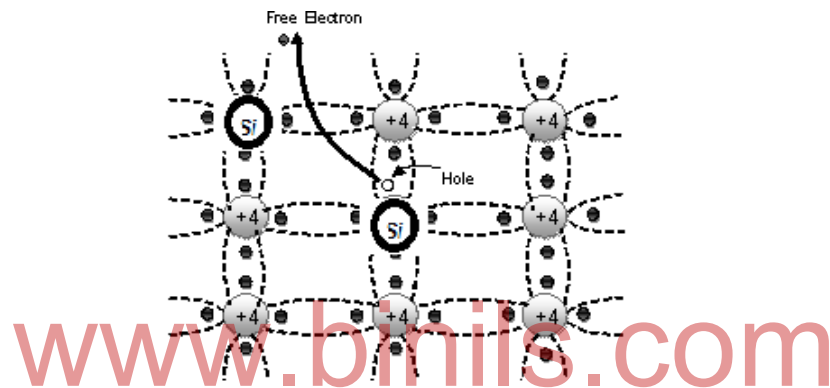

By breaking a co-valent bond, an electron-hole pair is created. This is done by giving external energy to the semiconductor. The valence band electrons get additional energy. When this energy exceeds the forbidden energy level, the valence electrons move to the conduction band. The missing electron in the valence band leaves a vacant space, which is known as a hole. In semiconductors even at room temperature electron-hole pairs are generated.

## Classification of semiconductors:

Semiconductors are classified as

1. Intrinsic or pure semiconductors
2. Extrinsic or impure semiconductors

## Intrinsic semiconductors:

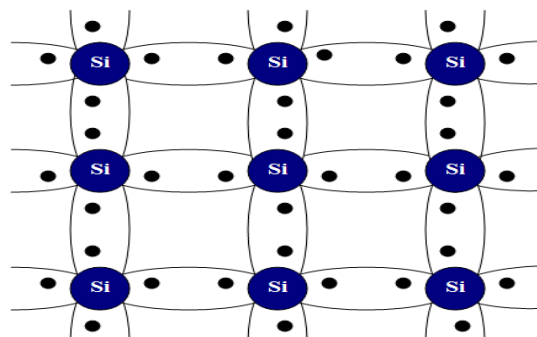

A pure semiconductor is called intrinsic semiconductor. At room temperature, some valence electrons get additional energy to break the co-valent bonds. So electron-hole pairs are created. When an electric field is applied, the current conduction takes place. The conduction is due to both electrons and holes. The total current is the sum of two currents due to free electrons and holes. It has poor conductivity. In intrinsic semiconductors, the total number of free electrons is always equal to the number of holes.

**Extrinsic semiconductor:**

To improve the conductivity, a small amount of impurity is added to the pure semiconductor. This type of semiconductor is known as impure or extrinsic semiconductor. The process of adding impurity is known as doping. 1 or 2 atoms are added to  $10^6$ . The extrinsic semiconductors are classified as n-type semiconductor & p-type semiconductor.

**N type semiconductor:**

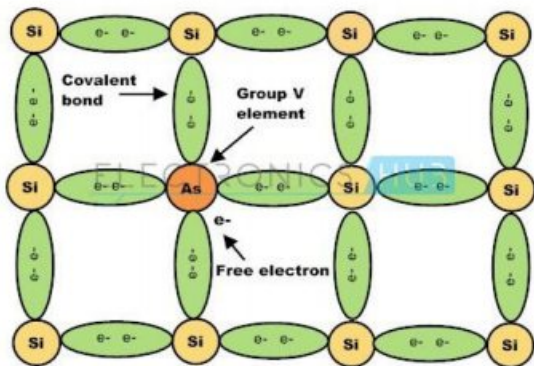

A small amount of pentavalent impurities (Arsenic, Antimony, and Phosphorous) are added to pure semiconductors. Silicon has 4 valence electrons and Arsenic has 5 valence electrons. Each atom forms a covalent bond with surrounding 4 Si atoms. 4 valence electrons of As is used for this bonding. The 5<sup>th</sup> electron is left free. This electron moves to the conduction band. So number of free electrons is increased. The conductivity is increased.

In addition to this electron-hole pairs are created due to room temperature. The pentavalent element is called donor impurity because it donates electrons for conduction. Here electrons are called majority carriers and holes are called minority carriers. The current conduction is mainly due to free electrons. In n-type semiconductors, number of free electrons is greater than number of holes.

**P type semiconductor:**

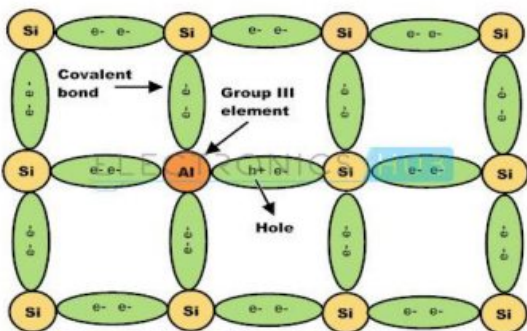

A small amount of trivalent impurities (Aluminium, Boron) are added to the pure semiconductors. Si has 4 valence electrons and Al has 3 valence electrons. 3 valence electrons in Al form co-valent bond with 4 surrounding atoms of Si. This leaves one bond incomplete which gives a hole. When a trivalent impurity is added to a pure semiconductor a large number of holes are created. These holes increase conductivity.

In addition electron-hole pairs are created due to room temperature. The trivalent impurity is called acceptor impurity because it accepts free electrons. Here holes are called majority carriers and electrons are called minority carriers. The current conduction is mainly due to holes. In p-type semiconductors, number of holes is greater than the number of free electrons.

**Drift current:**

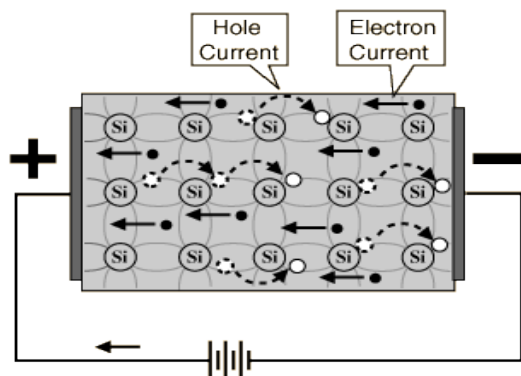

An electric field is applied across the semiconductor. The holes move towards the negative terminal of the battery. The electrons move towards the positive terminal of the battery. The effect of movement of charge carriers constitutes a current. This is called drift current. It can be defined as the flow of electric current due to the movement of the charge carriers under the influence of an external electric field.

**Diffusion current:**

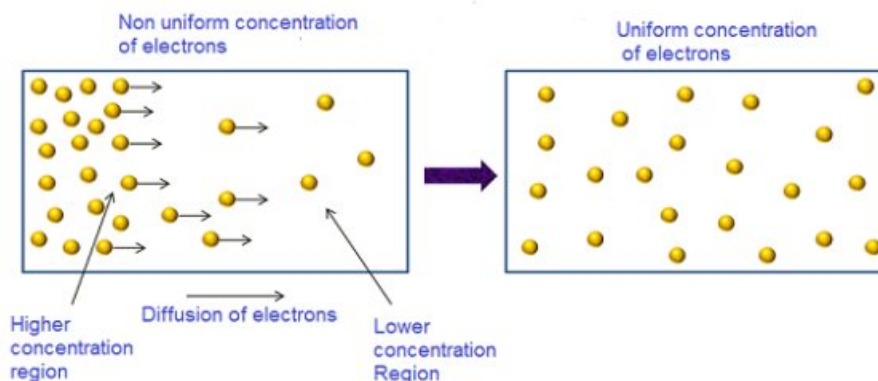

Copyright © 2013-2014, Physics and Radio-Electronics, All rights reserved

Let us assume that one type of charge carrier concentration is occurred at one end of semiconductor. There is a force of repulsion between the charge carriers. The result is that there is a tendency for the charge carriers to move gradually from the region of high concentration to one of low concentration. This movement continues until all the carriers are evenly distributed. This movement of carriers constitutes an electric current known as diffusion current.



## P-N Junction

In a piece of a semiconductor, if one half of is doped by p-type and the other half is doped by n-type impurities, P-N junction (diode) is formed. The n-type has high concentration of free electrons. The p-type has high concentration of holes. At the junction diffusion takes place.

### Open circuit:

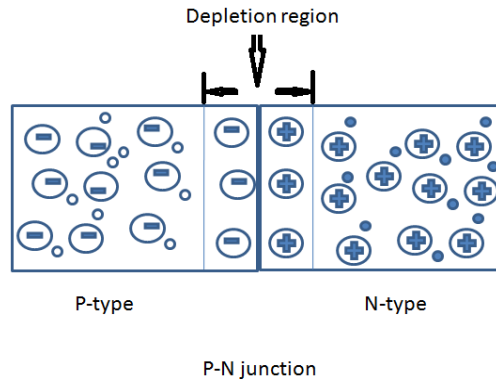

When free electrons move across the junction from n-type to p-type, the donor atoms becomes positively charged ions. The holes in p-type combined with free electrons. Therefore negative ions built on the p side of the junction. The net negative charge prevents further diffusion of electrons from n-side. These immobile ions set up a potential across the junction. This is called barrier potential, junction barrier, diffusion potential or contact potential. The region containing immobile ions is called depletion region or space charge region.

### Forward bias:

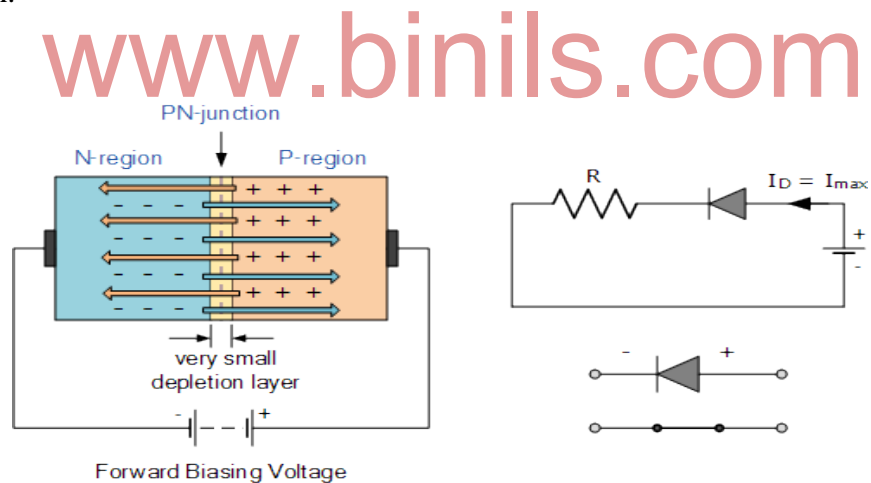

When positive terminal of the battery is connected to the p-type and negative terminal is connected to n-type, the bias is known as forward bias. The applied potential opposes barrier potential. The free electrons and holes move towards the junction. This reduces the width of the depletion region. Since the barrier potential is very small (0.7V for Si and 0.3V for Ge), a small forward voltage is enough to eliminate it. When the applied voltage is greater than the barrier potential, the electrons and holes cross the junction. These charges constitute current in forward direction. The junction offers very low resistance.

## Reverse bias:

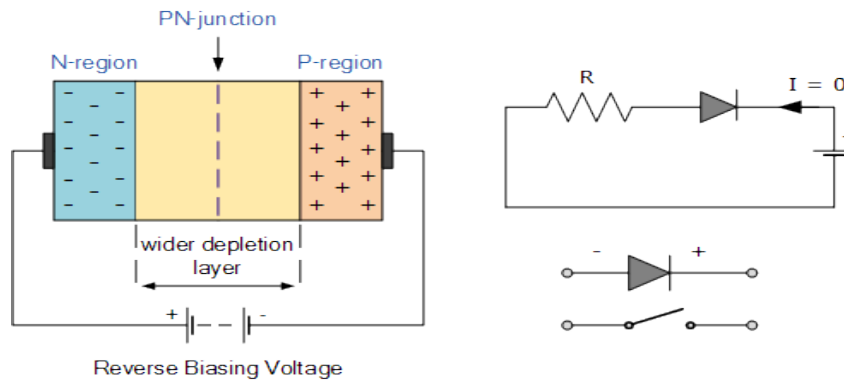

When negative terminal of the battery is connected to p-type and positive terminal is connected to n-type the bias is called reverse bias. Electrons in the n-side move towards the negative terminal. Holes in the p-side move towards the positive terminal. Now the barrier potential increases. The depletion region widens. No current flow in the external circuit. But in practice a very small current in the order of nano or micro ampere flows because of minority carriers. The junction offers very high resistance.

## V-I characteristics

It gives the relationship between voltage and current in the forward and reverse biases.

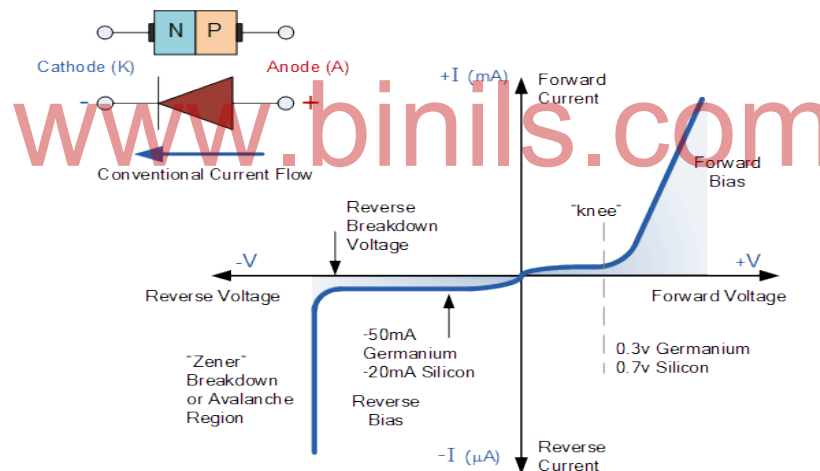

## Forward bias:

When supply voltage is increased, the current increases very slowly. The curve is non-linear (OA). The voltage is used to overcome the barrier potential. When this is removed, the current increases rapidly with the slight increase in applied voltage. The voltage at which the barrier potential is eliminated is called cut in voltage, knee voltage or threshold voltage. Its value is around 0.7V for Si and 0.3V for Ge. The region is almost linear (AB).

## Reverse bias:

Now minimum current flows because of minority carriers. This current is called reverse saturation current or reverse current  $I_0$ . This current increases slowly with the increase in supply voltage (OC). At one stage (point C), the break down occurs. The reverse current increases rapidly (CD). This may destroy the

junction permanently. The reverse voltage at which the junction breaks permanently is called breakdown voltage.

### Applications of the diodes:

1. Rectifier
2. Clippers
3. Clampers
4. Logic circuits
5. Modulation and demodulation circuits
6. Switch.

### Specifications of diode:

**Semiconductor material:** The semiconductor material used in the PN junction diode.

**Forward voltage drop ( $V_f$ ):** The voltage across a PN junction diode when it is ON.

**Peak inverse voltage (PIV):** It is the maximum reverse voltage that can be applied across the diode without breaking the junction.

**Junction capacitance:** All PN junction diodes exhibit a junction capacitance. The depletion region is the dielectric spacing between the two plates which are effectively formed at the edge of the depletion region and the area with majority carriers.

**Package type:** Diodes can be mounted in a variety of packages according to their applications.

### Zener diode:

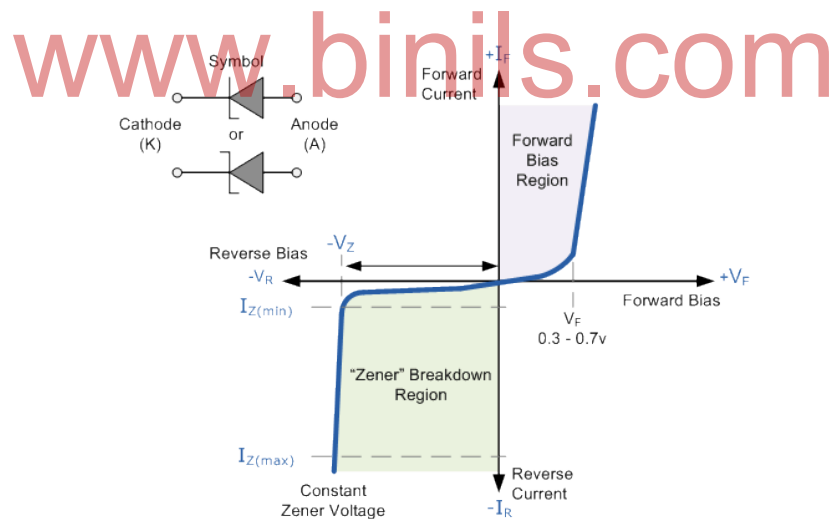

### Construction:

It is a specially designed p-n junction. It is a highly doped p-n junction. The doping ratio is  $1:10^3$ . It has a narrow depletion region. It is operated in the breakdown region. It is also called a voltage regulator diode or breakdown diode.

### Working:

In forward bias condition it acts as a normal p-n junction diode. In reverse bias, because of the high doping concentration, the breakdown occurs at a very low voltage. The breakdown is due to the strong electric field. Due to this field, direct rupture of co-valent bonds takes place.

## V-I characteristics:

The forward characteristics are similar to that of p-n junction diode. When the reverse voltage exceeds the break down voltage  $V_Z$ , the current increases very sharply. The voltage across the diode becomes constant. In break down region, it may be represented by a battery of voltage  $V_Z$  in series with the zener resistance  $R_Z$ .

## Breakdowns:

### Zener breakdown:

When the p and n regions are heavily doped, the depletion region width becomes very small. The doping ratio is about 1:  $10^3$ . Due to this, for an applied voltage of 6V or less, the field across the depletion region becomes very high in the order of  $10^7$  volts/meter. So direct rupture of co-valent bonds takes place.

### Avalanche breakdown:

It occurs in normally doped p-n junction. It occurs at large reverse voltage. Due to the electric field, thermally generated carriers acquire kinetic energy. The velocity of these carriers increases. They collide with the co-valent bonds and create new electron-hole pairs. The new carriers acquire additional energy from the field and collide with other atoms, thereby generating additional electron-hole pairs. This process is cumulative. This results in generation of large charge carriers. This process is known as avalanche multiplication. The junction breaks down and a large amount of reverse current flows.

### Difference between zener break down and avalanche break down:

S.No	Zener break down	Avalanche break down
1	Occurs in a heavily doped p-n junction	Occurs in a normally doped p-n junction
2	Occurs in low reverse voltage	Occurs in large reverse voltage
3	Because of high electric field, direct rupture of co-valent bonds takes place	Due to thermally generated carriers, ionization by collision takes place
4	Normally, the junction rebuilds again	Normally, the junction does not rebuild again

### Zener diode as a voltage regulator:

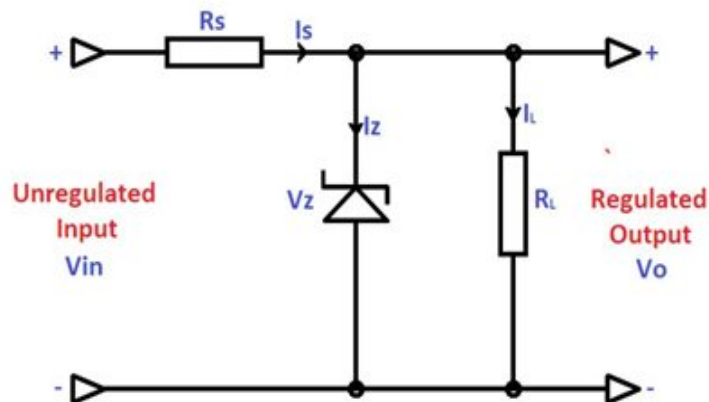

Here the zener diode Z is connected in reverse bias. The value of  $R_S$  is to be selected such that the zener current is above 50% of its maximum value. The current flowing through  $R_S$  is equal to the sum of the currents flowing through the diode and the load.

$$I = I_Z + I_L$$

When the load current remains constant and the UN regulated input voltage increases/decreases. The current drawn from the supply increases/decreases. Hence the zener current also increases/ decreases by the same amount. The supply current makes more/less voltage drops in  $R_S$ . This drop compensates the increase/ decrease in supply voltage. The output voltage remains constant.

$$V_O = V_{in} - I_S * R_S$$

When the input voltage is constant and the load current increases/ decreases. The zener diode current decreases/increases by the same amount. The total current through  $R_S$  remains the same. Therefore the voltage across  $R_S$  remains constant. Hence the output voltage remains constant. Thus the circuit keeps the output voltage constant irrespective of variations in supply voltage or load current.

### Disadvantages:

1. The output voltage depends upon zener voltage and cannot be varied.
2. Both  $I_L$  and  $I_Z$  flow through the series resistance, so there is a power loss in  $R_S$ .
3. Thus the efficiency will be low.

### Applications of zener diode:

1. Voltage regulator.
2. Peak clippers.
3. Fixed reference voltage source.

### Specifications of Zener diode:

**Voltage  $V_z$ :** The Zener voltage or reverse voltage at which the diode breaks down.

**Current:** The current,  $I_{ZM}$ , of a Zener diode is the maximum current that can flow through a Zener diode at its rated voltage,  $V_Z$ .

**Zener resistance  $R_z$ :** The IV characteristic of the Zener diode is not completely vertical in the breakdown region. The voltage change for a given change in current is the resistance of the diode. This value of resistance, often termed the resistance is designated  $R_z$ .

**Power rating:** This defines the maximum power that can be dissipated by the package.

**Package type:** Diodes can be mounted in a variety of packages according to their applications.

### RECTIFIERS:

#### Definition:

It is an electronic circuit which converts A.C in to D.C.(unidirectional current).

#### Types:

1. Half wave rectifier
2. Full wave rectifier with centre tapped transformer
3. Bridge rectifier.

**Ripple:** The A.C. components present in the rectified output is called ripple.

**Ripple factor:** It is defined as the ratio of the rms value of the A.C. component of voltage/current to the D.C. component of voltage/current.

$$R.F. = V_{rms} / V_{dc} \text{ or } I_{rms} / I_{dc}$$

**Rectification efficiency:** It is defined as the ratio of D.C. power output at the load to the A.C. power input to the rectifier.

$$\eta = \text{D.C. power output} / \text{A.C power input} \times 100\%$$

**Peak inverse voltage (PIV):** It is the maximum reverse voltage that can be applied across the diode without breaking the junction.

**Half wave rectifier:**

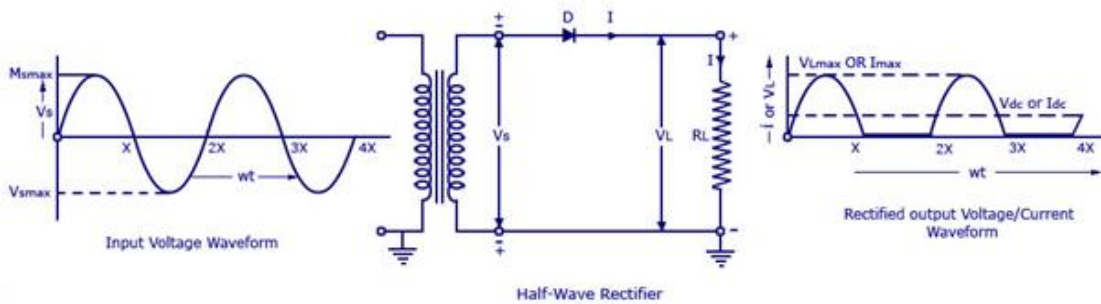

The circuit is shown in the figure. It uses one diode. When point A is positive w.r.to point B (1<sup>st</sup> half of the input), the diode is forward biased and conducts. The current flows from A through D, X, Y, B and back to A. X becomes positive w.r.to Y. During the 2<sup>nd</sup> half of the input, point A becomes negative. The diode becomes reverse biased. It does not conduct current. The output is zero. The wave forms are shown in the figure. So the circuit uses one half of the input and it is called half wave rectifier.

**Characteristics:**

- Ripple frequency = supply frequency
- Ripple factor = 1.21
- PIV =  $E_M$
- Rectification efficiency =  $40.6 / (1 + R_F / R_L) \%$
- Where,  $R_F$  is the resistance of the diode and  $R_L$  is the load resistance.

**Full wave rectifier with centre tapped transformer:**

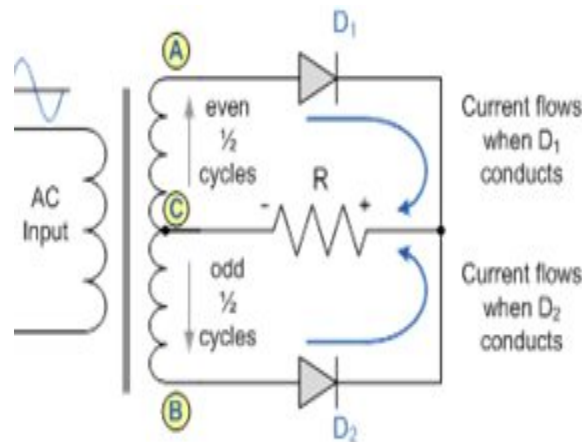

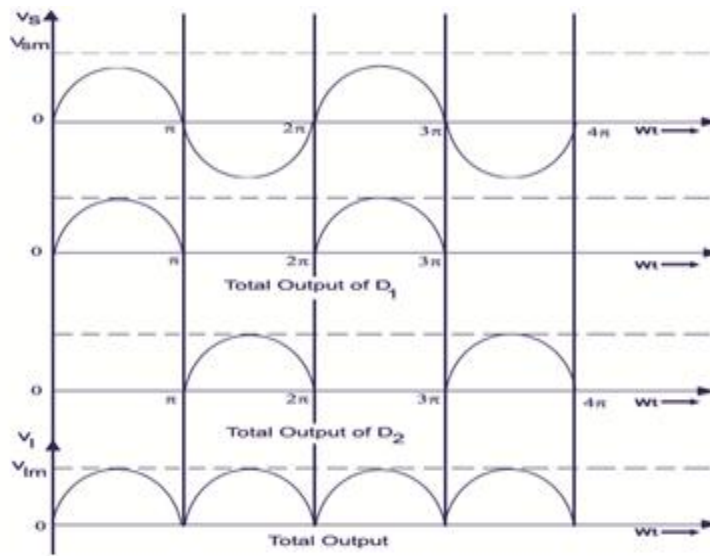

A full wave rectifier converts A.C. into D.C by using both the half cycles of the input. It uses 2 diodes. During the positive half cycle of the input, point A becomes positive w.r. to B. D1 is forward biased and conducts current  $I_1$ . This current flows from X to Y making X positive. During this period D2 is reverse biased. During the negative half cycle of the input, point B becomes positive w.r. to A. D2 is forward biased and conducts current  $I_2$ . This current flows from X to Y making X positive. During this period D1 is reverse biased. The direction of both the currents is same through load resistance.

#### Characteristics:

- Ripple frequency = twice the supply frequency
- Ripple factor = 0.4285
- $PIV = 2 E_M$
- Rectification efficiency =  $81.2 / (1 + R_F / R_L) \%$
- Where,  $R_F$  is the resistance of the diode and  $R_L$  is the load resistance.

#### Bridge rectifier:

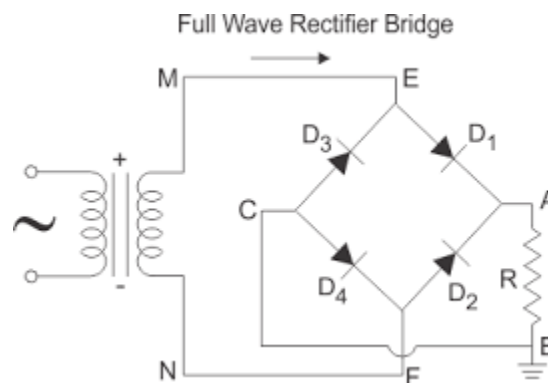

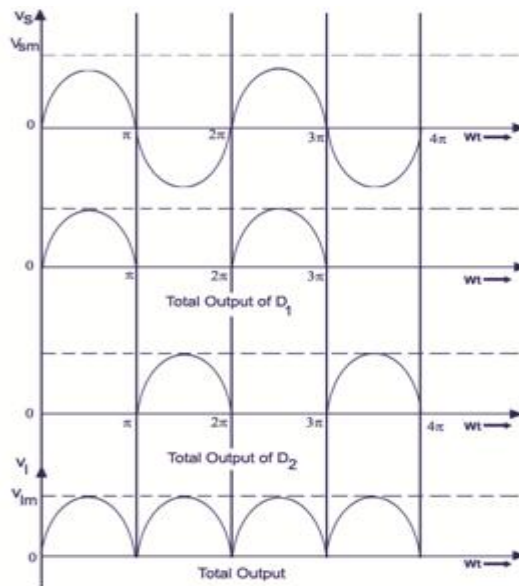

A full wave rectifier converts A.C. into D.C by using both the half cycles of the input. It uses 4 diodes. During the positive half cycle of the input, point A becomes positive w.r.to B. D1 and D4 are forward biased and conduct current  $I_1$ . This current flows from X to Y making X positive. During this period D2 and D3 are reverse biased. During the negative half cycle of the input, point B becomes positive w.r.to A. D2 and D3 are forward biased and conduct current  $I_2$ . This current flows from X to Y making X positive. During this period D1 and D4 are reverse biased. The direction of both the currents is same through load resistance.

**Characteristics:**

[www.binils.com](http://www.binils.com)

- Ripple frequency = twice the supply frequency
- Ripple factor = 0.4285
- $PIV = E_M$
- Rectification efficiency =  $81.2 / (1 + R_F / R_L) \%$
- Where,  $R_F$  is the resistance of the diode and  $R_L$  is the load resistance.

**COMPARISON BETWEEN RECTIFIERS:**

S.No	Parameter	Halfwave Rectifier	Fullwave Rectifier	Bridge Rectifier
1	Number of diodes	2	4	4
2	Ripple frequency	F	2F	2F
3	Ripple factor	1.21	0.48	0.48
4	Efficiency	40.8%	81.6%	81.6%
5	Peak Inverse Voltage	$V_m$	$2 V_m$	$V_m$



## FILTERS:

### Definition:

It is a circuit which eliminates unwanted frequencies present in the rectified output.

### Capacitor filter or C filter:

Fullwave Rectifier with Capacitor Filter

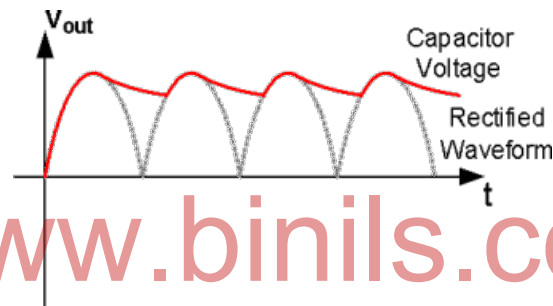
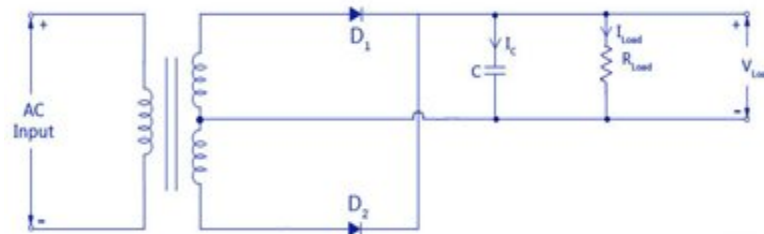

Here a capacitor is connected across the load resistor. The capacitive reactance  $X_C = 1 / 2\pi fC$ . For D.C.  $f = 0$ , so  $X_C = \text{infinity}$ ; it offers very high resistance. For A.C.  $f = \text{high}$ , so  $X_C = \text{low}$ ; it offers very low resistance. The ripples are removed and pure D.C. voltage appears in the output. The capacitor gets charged during the conduction period and energy is stored in it. During non conduction period, the capacitor discharges through the load resistance. Therefore throughout the A.C. cycle, current flows in the load resistance.

### Applications:

- This filter has poor voltage regulation and mainly used for low current applications.

### LC or L section filter:

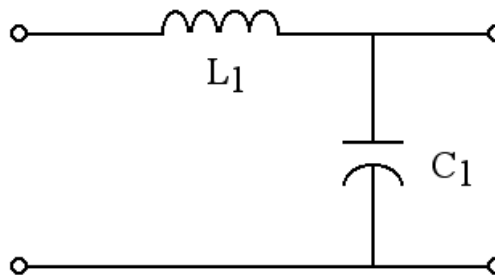

It is also called as choke coil input filter. The capacitive reactance  $X_C = 1 / 2\pi fC$ . For D.C.  $f = 0$ , so  $X_C = \text{infinity}$ ; it offers very high resistance. For A.C.  $f = \text{high}$ , so  $X_C = \text{low}$ ; it offers very low resistance. The inductive reactance  $X_L = 2\pi fL$ . For D.C.  $f = 0$ , so  $X_L = 0$ ; it offers very low resistance. For A.C.  $f = \text{high}$ , so  $X_L = \text{high}$ ; it offers very high resistance. The inductor blocks A.C. and allows D.C. The capacitor blocks D.C. and allows A.C. So, pure D.C. appears across the output.

**Applications:**

- It has very good voltage regulation. It is used for high current applications.

**Π Section filter:**

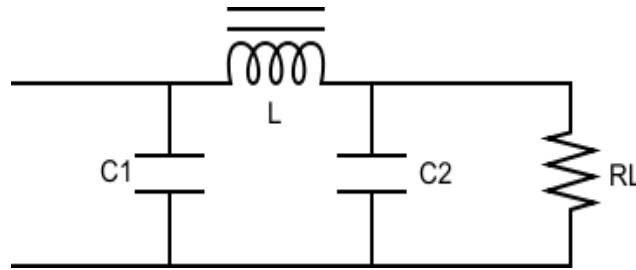

It is also called as capacitor input filter. The capacitive reactance  $X_C = 1 / 2\pi fC$ . For D.C.  $f = 0$ , so  $X_C = \text{infinity}$ ; it offers very high resistance. For A.C.  $f = \text{high}$ , so  $X_C = \text{low}$ ; it offers very low resistance. The inductive reactance  $X_L = 2\pi fL$ . For D.C.  $f = 0$ , so  $X_L = 0$ ; it offers very low resistance. For A.C.  $f = \text{high}$ , so  $X_L = \text{high}$ ; it offers very high resistance. C1 blocks D.C. and allows A.C. The remaining ripples are blocked by L. C2 blocks D.C. and allow A.C. So, pure D.C. appears across the output.

[www.binils.com](http://www.binils.com)

## UNIT – II

### BIPOLAR JUNCTION TRANSISTOR

#### Introduction:

#### Transistor:

A bipolar junction transistor (BJT) has two PN-junctions. It is a device which transforms current flow from a low resistance path to a high resistance path. This transfer of current through resistance has given the name to the device transfer resistor or transistor. Since this device is made up of two junction diodes. It is generally called junction transistor.

There are two types of junction transistors:

Uni-polar junction transistors	Bipolar junction transistors
Only majority carrier's transport the current.	Interaction of both the majority and minority carriers transport the current.

#### Constructional Details:

A bipolar junction transistor is simply a sandwich of one type of semiconductor material (p-type or n-type) between two layers of the other type. A block representation of a layer of n-type material between two layers of p-type is shown in Figure: (a). This is described as PNP transistor. Figure: (b). shows an NPN transistor, consisting of a layer of p-type material between two layers of n-type.

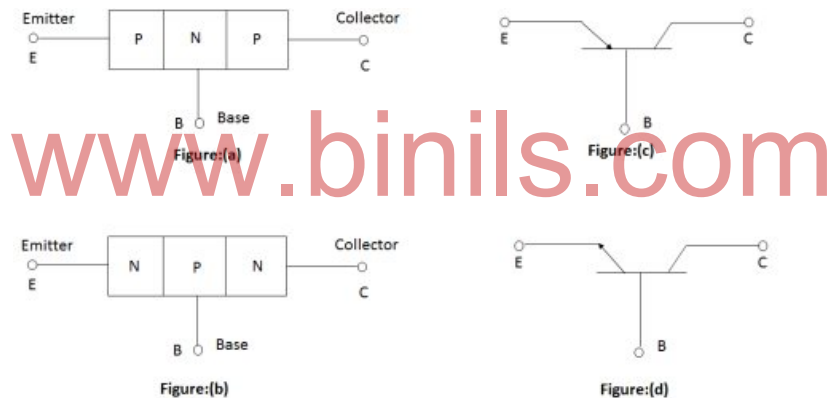

The center layer is called the base, one of the outer layers is termed the emitter, and the other outer layer is referred to as the collector. The emitter, base and collector are provided with terminals, which are appropriately labeled E, B, and C. Two PN junctions exist within each transistor: the collector-base junction and the emitter-base junction.

Circuit symbols for PNP and NPN transistors Figure: (c) and Figure: (d) together with the corresponding block representations. The arrowhead on each symbol always identifies the emitter terminal of the transistor. Also, in each case its direction indicates the conventional direction of current flow. For the NPN transistor, the arrowhead points from the p-type base to the n-type emitter. For the PNP transistor, it points from the p-type base. Thus, the arrowhead is always from p to n.

The center layer of the transistor is made very much narrower than the two outer layers. Also the outer layers are much more heavily doped than the center layer. This causes the depletion regions to penetrate deeply into the base, and thus the distance between the emitter-base (EB) and collector-base (CB) depletion regions is minimized.

## Transistor Biasing:

The application of a suitable D.C. voltage, across the transistor terminals is called Biasing.

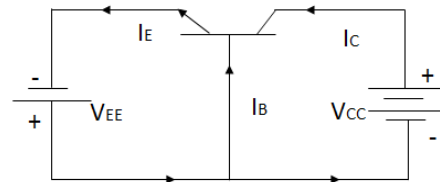
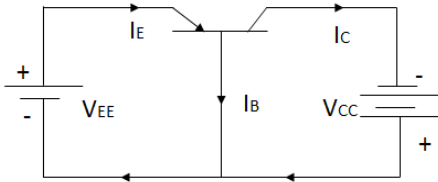
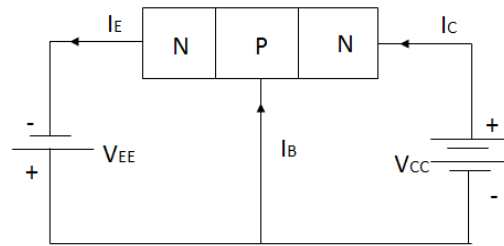
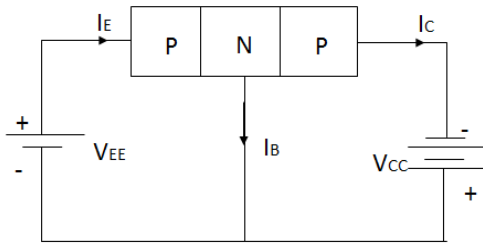

Figure (a) : PNP transistor

Figure (b) : NPN transistor

In order to have a normal function of transistor it is necessary to apply voltage of a correct polarity across its two junctions. This is called biasing. The bias and supply voltage polarities for NPN and PNP transistors are shown in fig (a) & (b). For NPN points from the (positive) base to the (negative) emitter. The collector is then biased to a higher positive level than the base. For a PNP device the base is negative with respect to the emitter. The arrowhead a point from the (positive) emitter to the (negative) base, and the collector is then more negative than the base. Typical base-emitter voltages for both NPN and PNP transistors are 0.7V for silicon and 0.3V for germanium.

## TRANSISTOR OPERATION:

### PNP Transistor:

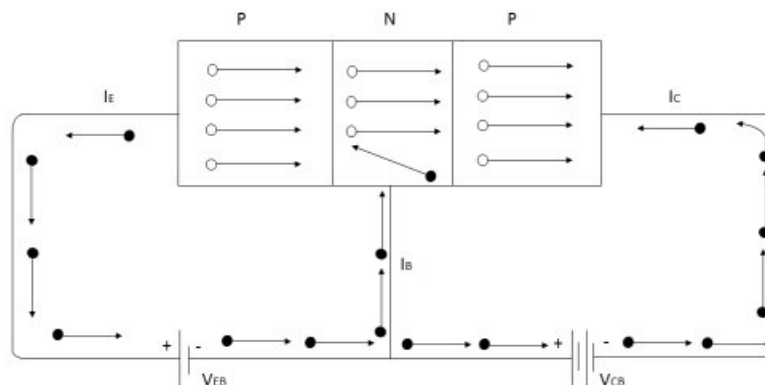

Fig shows the basic connection of a PNP transistor. A small value battery  $B_1$  forward biases the emitter-base junction of a PNP and the collector-base junction is reverse biased by a high value battery  $B_2$ . The positive terminal of the battery  $B_1$  repels the holes in the P-region on the left. These holes in the P-Type emitter to flow towards the base. This constitutes the emitter current  $I_E$ . As these holes cross into the N-Type base, they tend to combine with the electrons. As the base is lightly doped and very thin, therefore only a few holes (less than 5%) combine with the electrons. The remainders (more than 95%)

cross into the collector region. The negative terminal of the battery  $B_2$  attracts these holes. This constitutes the collector current  $I_C$ . In this way almost the entire emitter current flows in the collector circuit. It may be noted that current conduction with in PNP transistor is by holes. Therefore, the emitter current

$$I_E = I_B + I_C.$$

**NPN Transistor:**

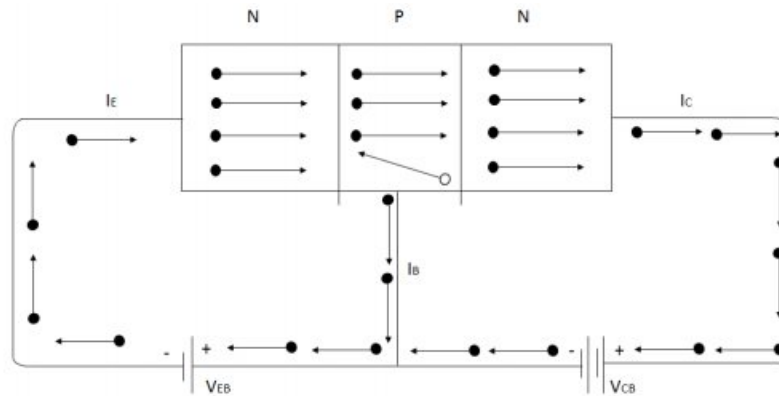

Fig shows the basic connection of a NPN Transistor. A small value battery  $B_1$  forward biases the emitter-base junction of a NPN and the collector–base junction is reverse biased by a high value battery  $B_2$ . The negative terminal of the battery  $B_1$  repels the electrons in the N-region on the left. This electron in the N-Type emitter to flow towards the base. This constitutes the emitter current  $I_E$ . As these electrons cross into the P-Type base, they tend to combine with the holes. As the base is lightly doped and very thin, therefore only a few electrons (less than 5%) combine with the holes. The remainder (more than 95%) crosses into the collector region. The positive terminal of the battery  $B_2$  attracts these electrons. This constitutes the collector current  $I_C$ . In this way almost the entire emitter current flows in the collector circuit. It may be noted that current conduction with in NPN transistor is by electrons. Therefore, the emitter current

$$I_E = I_B + I_C.$$

**Transistor as a switch:**

The transistor as a switch operates between two states namely saturation and cut off state. The typical transistor circuit is shown in figure. It consists of a transistor with collector load resistance  $R_c$ . The input is given at base terminal and output is taken at collector terminal.

When the input signal is negative, the emitter base junction will reverse biased and the transistor never comes to conduction state. The transistor will be in cut off and no current flows in the load resistance  $R_c$ . As a result, there is no voltage drop across  $R_c$ .

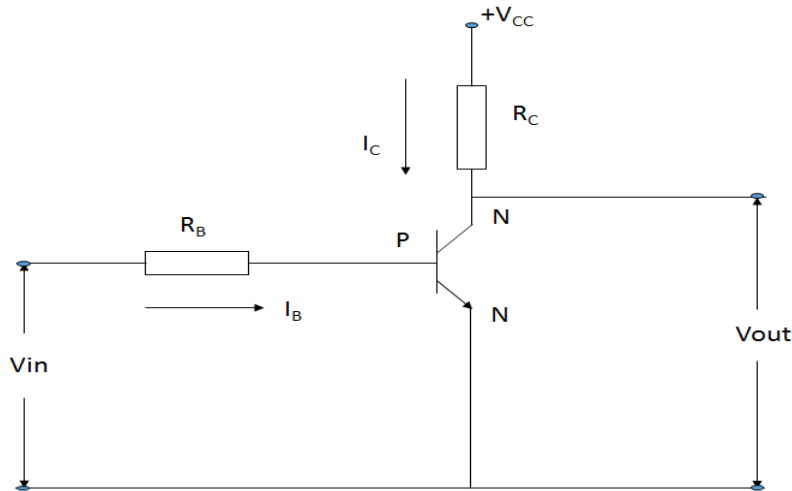

Hence the output voltage will be supply voltage i.e.  $V_o = V_{cc}$ . It is equal to open circuit voltage since the transistor is in cut off.

When the input voltage is positive, it forward biases the base-emitter junction and the transistor will come to conduction state. Now maximum current will be flowing from collector to emitter and all the  $V_{cc}$  is dropped across  $R_c$ . Thus the output voltage will be zero. i.e.  $V_o = 0$ . Hence the transistor is turned on and off depending upon whether the input bias voltage is positive or negative. Thus a transistor can act as a switch.

**Advantages:**

[www.binils.com](http://www.binils.com)

1. It has no moving point.
2. It gives noiseless operation.
3. It has smaller size and weight.
4. It gives trouble free service because of solid state.
5. It is cheaper than other switches.
6. It requires less maintenance.
7. It has a very fast speed of switching operation.

**TRANSISTOR AS AN AMPLIFIER:**

The operation of a transistor as an amplifier is based on the fact that base current,  $I_B$  in a transistor can control the collector current,  $I_C$ . The base current can be varied by variation of forward bias and this produce corresponding variation in the collector current.

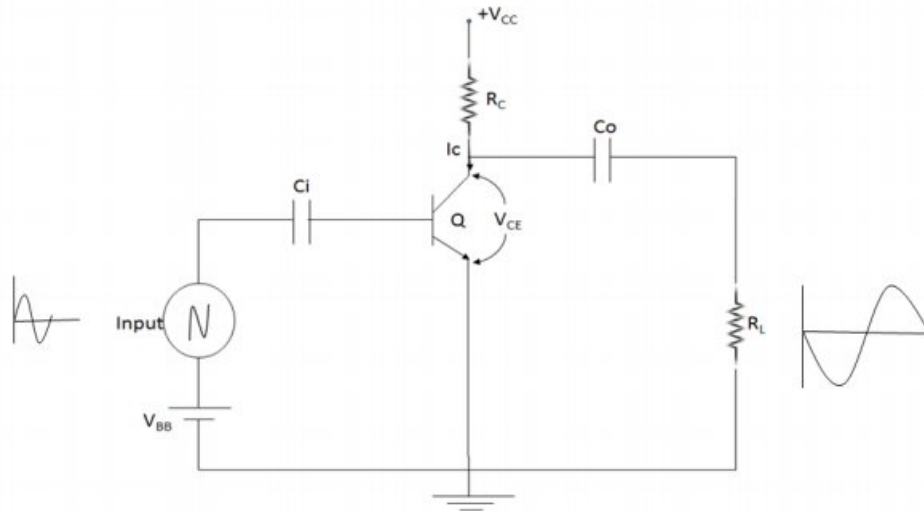

Figure : Transistor as an amplifier

The weak signal is applied between emitter-base junction and output is taken across the load  $R_L$  connected in the collector circuit. The emitter-base junction in a transistor is forward-biased and, as such the input impedance is low. On the other hand, the base-collector is reverse biased and hence the output impedance is very high. A D.C voltage  $V_{BE}$  is applied in the input circuit in addition to the signal. This D.C voltage magnitude is such that it always keeps the input forward biased regardless of the polarity of the signal.

Even a small change in signal voltage caused an appreciable change in emitter current, since the input circuit has low resistance. Due to transistor action the same change in collector current take place. The collector flows through a large load resistance ( $R_C$ ), which in turn produces a large voltage across it. Thus a weak signal applied in the input circuit appears in the amplified form in the collector circuit. In this way transistor acts as an amplifier.

### TRANSISTOR BIASING:

The amplifiers which are used to magnify the weak signal without change in its wave shape and frequency are called faithful amplifiers. For faithful amplifications, the transistor amplifier must satisfy three basic conditions. They are namely:

1. Proper zero signal collector current.
2. Proper base to emitter voltage at any instant.
3. Proper collector to emitter voltage at any instant.

The technique of transistor biasing is used to fulfill the above said three conditions. The Proper flow of zero signal collector current and the maintenance of proper collector-emitter voltage during the passage of signal is known as transistor biasing.

The basic purpose of transistor biasing is to keep the base-emitter junction properly forward biased and collector-emitter junction properly reverse biased during the application of signals. That means the transistor must operate only in active region. This can be achieved by using bias battery of resistor circuit with the transistor. The resistor method is more efficient and is frequently used. The circuit used for proper biasing of the transistor is called biasing circuit. This circuit used to fix the operating point at a particular level for satisfying the above said basic conditions.

In the interest of simplicity and economy, it is desirable that transistor circuit should have a single source of supply – the one in the output circuit (supply voltage  $V_{CC}$ ). The following are most commonly used methods of biasing circuits.

1. Fixed bias.
2. Collector to base bias.
3. Self bias.

**1.Fixed bias or Base resistor method:**

A common emitter amplifier using fixed bias circuit is shown in fig. In this method, a high resistance  $R_B$  is connected in between the base and positive end of supply voltage  $V_{CC}$ . The required zero signal base current is provided by  $V_{CC}$  and it flows through  $R_B$ .

$$\text{Let } \beta = \frac{I_C}{I_B}$$

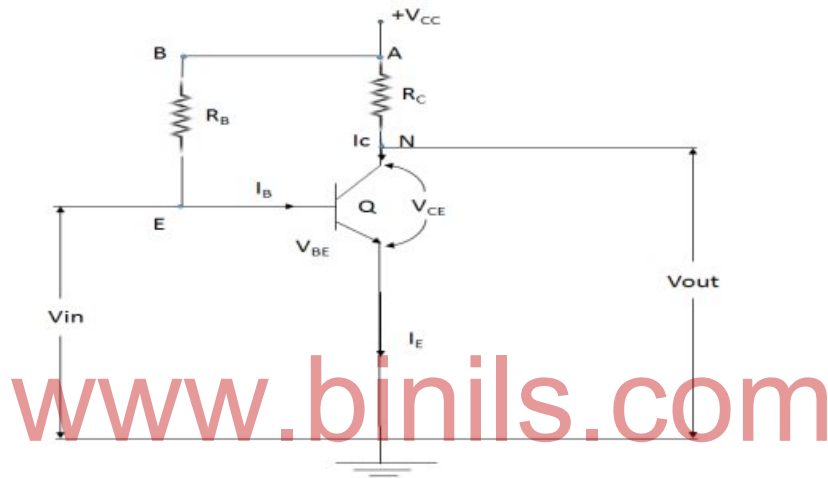

Figure: Fixed bias

Considering the closed circuit ABENA and applying kirchoff's voltage law, we get

$$\begin{aligned} V_{CC} &= I_B R_B + V_{BE} \\ \text{Therefore, } I_B R_B &= V_{CC} - V_{BE} \\ R_B &= \frac{V_{CC} - V_{BE}}{I_B} \end{aligned}$$

As  $V_{CC}$  and  $I_B$  are known and  $V_{BE}$  can be seen from the transistor manual. Therefore, the value of  $R_B$  can be easily calculated.

$$\text{Stability factor, } S = \frac{1 + \beta}{1 - \beta \frac{dI_B}{dI_C}}$$

In fixed bias,  $I_B$  is independent of  $I_C$ , so that  $dI_B / dI_C = 0$ . Hence stability factor,  $s = \beta + 1$ . Since  $\beta$  is a large quantity, this is a very poor bias stable circuit. The collector current  $I_C$  changes ( $\beta + 1$ ) times as much as any change in  $I_{C0}$ . Therefore, this circuit is not used for biasing the transistor.



**Advantages:**

1. Simplicity.
2. Less number of components
3. No loading of the source by biasing circuit.
4. Easily set the biasing conditions.

**Disadvantages:**

1. Poor stabilization.
2. Stability factor is very high. Therefore, there are strong chances of thermal runaway.

**2. Collector to base bias (Biasing with feedback resistor):**

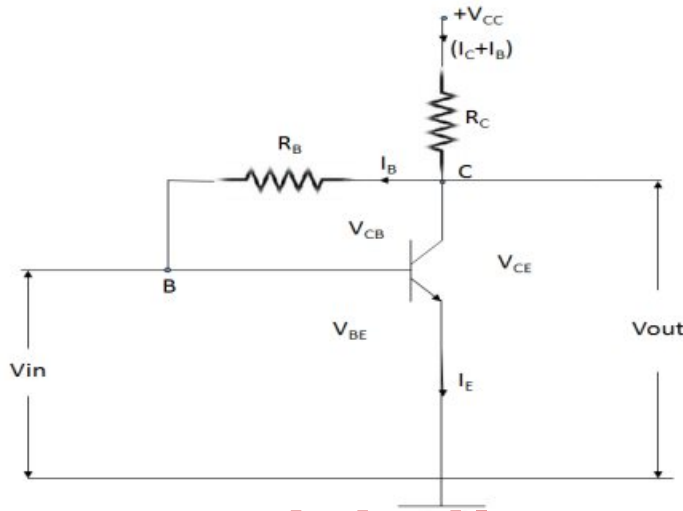

Figure : Collector to Base bias (Biasing with feedback resistor)

A common emitter amplifier using collector to base bias circuit is shown in the fig. In this method, a resistor  $R_B$  is connected in between collector and base determined by the collector-base voltage  $V_{CB}$ . The voltage  $V_{CB}$  forward biases the base-emitter junction and hence base current  $I_B$  flows through  $R_B$ . This caused zero signal collector current flow in the circuit.

The loop equation for this circuit is

$$V_{CC} = (I_C + I_B) R_C + I_B R_B + V_{BE}$$

$$V_{CC} - V_{BE} - I_C R_C$$

$$I_B = \frac{V_{CC} - V_{BE} - I_C R_C}{R_C + R_B}$$

Therefore

$$\frac{dI_B}{dI_C} = \frac{R_C}{R_C + R_B} \cdot \frac{1}{1 + \beta}$$

Stability factor,  $S = \frac{1}{1 - \beta \left( \frac{dI_B}{dI_C} \right)}$

$$\text{Hence } S = \frac{\beta + 1}{1 + \beta \left[ \frac{R_C}{R_C + R_E} \right]}$$

The stability can be improved by choosing low value of  $R_B$  and high value of  $R_C$ . If  $R_C$  is very small, then  $S = \beta + 1$  i.e. stability is very poor. Hence the value of  $R_C$  is quite large for good stabilization. This method provides better thermal stability than the fixed bias.

**Advantages**

1. Simple circuit
2. High stability compared with fixed bias

**Disadvantages**

1. The circuit provides negative feedback, which reduces the gain of the amplifier.

**3. Self bias (Emitter bias or Voltage divider bias):**

A common emitter amplifier using self bias circuit is shown in the fig. It is the most widely used method of providing biasing and stabilization to a transistor. In this method, two resistors  $R_1$  and  $R_2$  are connected across the supply voltage  $V_{CC}$ . A resistor  $R_E$  is connected to the emitter terminal provides for stabilization. The voltage drop across  $R_2$  forward biases the base-emitter junction. This causes the base current and collector current flow in zero signal conditions.

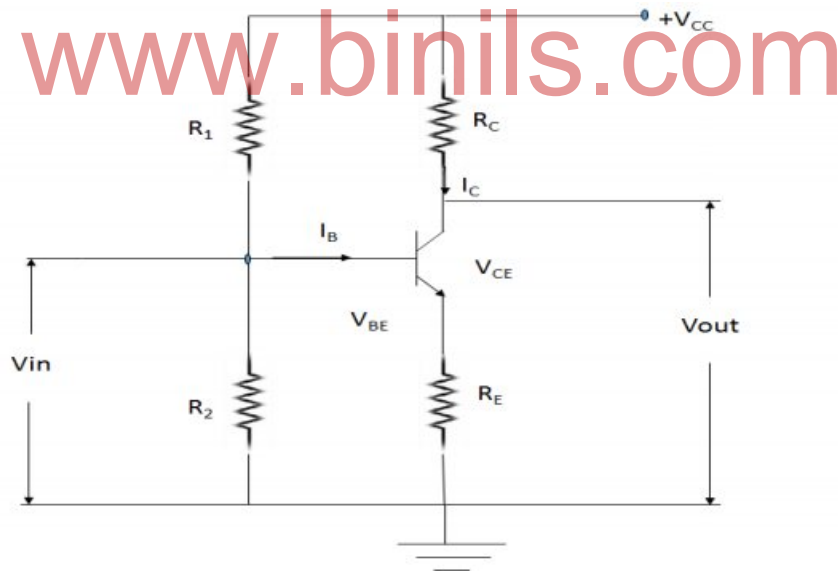

If  $I_{CO}$  tends to increase due to increase with temperature, the collector current  $I_C$  increases and also the current in  $R_E$  increases. Hence the voltage drops across  $R_E$  increases, thereby decreasing the base current. As a result,  $I_C$  is maintained almost constant. The current in emitter resistor  $R_E$  causes a voltage drop which is in the direction to reverse bias the base emitter junction. For this, the transistor is always in active region.

$$\text{Voltage drop across } R_2, V_2 = \frac{R_2 V_{CC}}{R_1 + R_2} \text{ and}$$

$$R_B = \frac{R_1 R_2 [R_B = R_1 // R_2]}{R_1 + R_2}$$

The loop equation around the base circuit can be written as.

$$\begin{aligned} V_{in} = V_2 &= I_B R_B + V_{BE} + I_E R_E \\ V_2 &= I_B R_B + V_{BE} + (I_B + I_C) R_E \quad [I_E = I_B + I_C] \\ I_B (R_B + R_E) &= V_2 - V_{BE} - I_C R_E \end{aligned}$$

$$I_B = \frac{V_2 - V_{BE} - I_C R_E}{R_B + R_E}$$

Differentiating the equation with respect to  $I_C$ , we get

$$\frac{dI_B}{dI_C} = \frac{R_E}{R_B + R_E}$$

$$\text{Stability factor, } S = \frac{\beta + 1}{1 - \beta \left[ \frac{dI_B}{dI_C} \right]}$$

www.binils.com

Substituting the value of  $\frac{dI_B}{dI_C}$  in the above equation, we get

$$S = \frac{\beta + 1}{1 + \beta \left[ \frac{R_E}{R_B + R_E} \right]}$$

Therefore,  $S = (\beta + 1) \frac{\beta + 1}{1 + \beta \left[ \frac{R_E}{R_B + R_E} \right]}$

$$1 + \beta \left[ \frac{R_E}{R_B + R_E} \right]$$

The ratio of  $(R_B / R_E)$  is very small, and then it can be neglected.

$$\text{Stability factor} = \frac{\cancel{(\beta + 1)}}{\cancel{(\beta + 1)}}$$

Stability factor = 1

This is the smallest possible value of S and gives maximum possible thermal stability.

### Transistor Configuration:

To investigate the characteristics of a two terminal device (a diode), several levels of forward or reverse bias voltage are applied and the corresponding currents that flow are measured. Plotting the graphs of current against voltage then derives the characteristics of the device. Since a transistor is a three terminal device, there are three possible configurations in which it may be connected to study its characteristics. From each of this configuration, three sets of characteristics may be derived. A transistor can be connected in a circuit in the following three ways (called configuration).

1. Common base (CB)
2. Common emitter(CE)
3. Common collector(CC)

The word common is used to mention the particular terminal which is common to both the input and output circuit. Since a transistor is a three terminal device, one of its terminal has to common to both the input and output circuits. Generally,the common terminal is grounded. Then the mode of operation can be called grounded base, grounded emitter and grounded collector configuration.

### COMMON BASE CHARACTERISTICS:

#### Common base connection:

In this configuration the input is applied between the emitter and base and the output is taken from the collector and the base. Here the base is common to both the input and the output circuits as shown in fig.

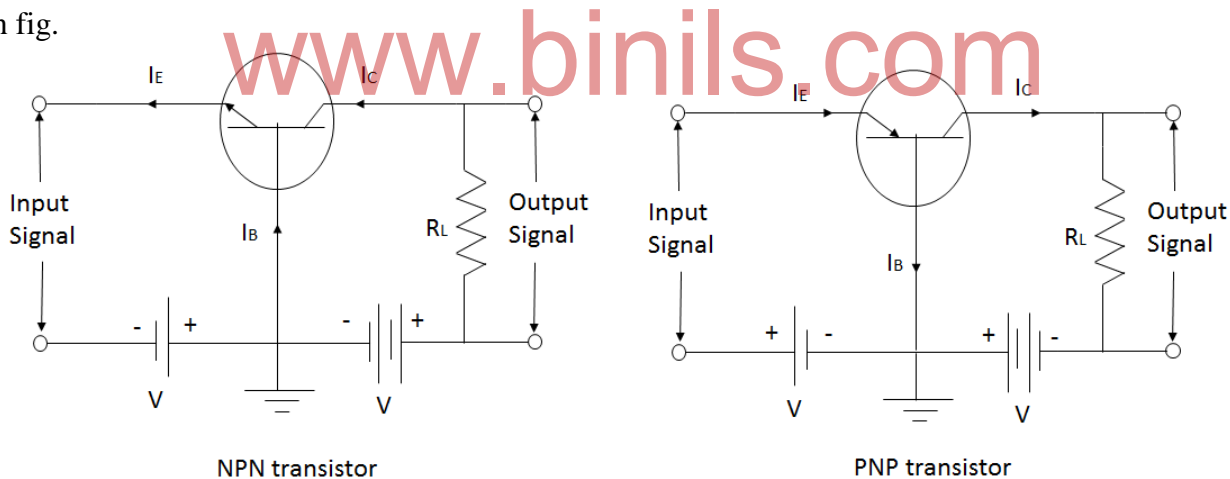

In a common base configuration, the input current is the emitter current  $I_E$  and the collector current  $I_C$ . The ratio of change in collector current to the change in emitter current at constant collector-base voltage is called current amplification factor.

$$\beta_{CB} = \frac{\Delta I_C}{\Delta I_E} \text{ at constant } V_{BC}$$

In a transistor  $V_{EB}$ ,  $I_E$ ,  $I_C$ ,  $V_{CB}$  are parameters. In the above connection voltmeters and ammeters are connected to measure input and output voltages and currents as shown in fig.

## Characteristics of Common Base Configuration:

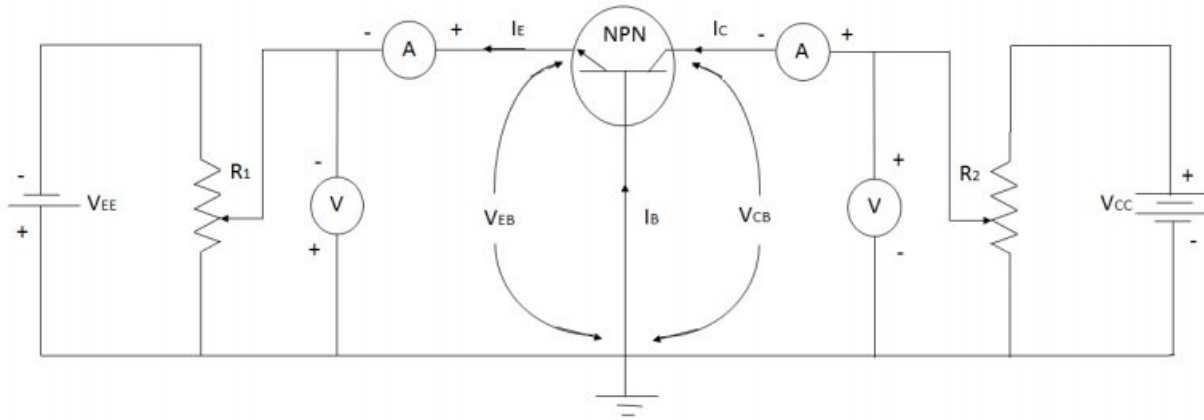

The circuit arrangement for determining the characteristics of a common base NPN transistor is shown in fig. In this circuit, the collector to base voltage ( $V_{CB}$ ) can be varied by adjusting the potentiometer  $R_2$ . The emitter to base voltage ( $V_{BE}$ ) can be varied by adjusting the potentiometer  $R_1$ . The DC voltmeters and DC millimeters are connected in the emitter and collector circuits to measure the voltages and currents.

### Input characteristics:

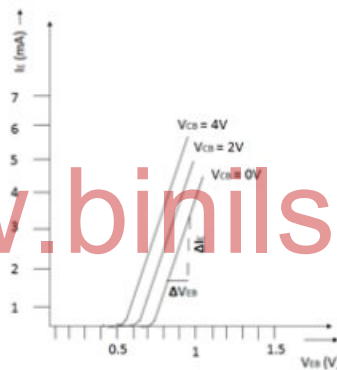

The curve plotted between the emitter current ( $I_E$ ) and the emitter to base voltage ( $V_{BE}$ ) at constant collector to base voltage ( $V_{CB}$ ) are known as input characteristics of a transistor in common base configuration.

### Output characteristics:

The emitter current  $I_E$  is held constant at each of several fixed levels. For each fixed level of  $I_E$ , the output voltage  $V_{CB}$  is adjusted in convenient steps, and the corresponding levels of collector current  $I_C$  are recorded. In this way a table of values is obtained from which a family of output characteristics may be plotted. In fig the corresponding  $I_C$  and  $V_{CB}$  levels obtained when  $I_E$  was held constant at 1mA are plotted, and the resultant characteristic is identified as  $I_E = 1\text{mA}$ . Similarly, other characteristics are plotted for  $I_E = 2\text{mA}$ ,  $3\text{mA}$ , etc.

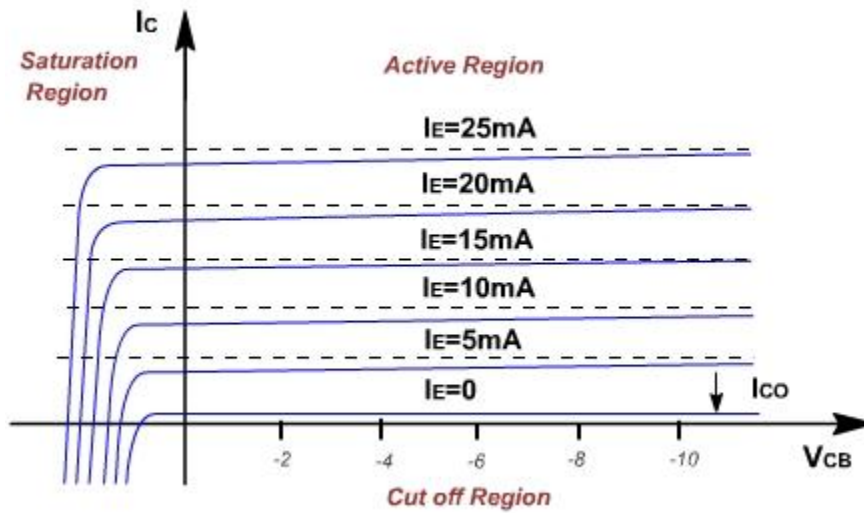

1. The common base output characteristics in fig. show that for each fixed level of  $I_E$ ,  $I_C$  is almost equal to  $I_E$  and appears to remain constant when  $V_{CB}$  is increased.
2. This characteristic may be used to find the output resistance ( $r_o$ ).

$$r_o = \frac{\Delta V_{CB}}{\Delta I_C} \text{ at constant } I_E$$

3. A very large change in collector-base voltage produces small change in collector current. It means that the output resistance is very high.

4. The collector is constant above certain values of collector-base voltage. It means that  $I_C$  is independent of  $V_{CB}$  and depends upon  $I_E$  only.

The output characteristics may be divided into three regions and these regions are plotted in the fig.

1. The active region
2. Cut-off region
3. Saturation region

#### Active region:

In this region the collector junction is reverse biased and the emitter junction is forward biased. In this region when  $I_E = 0$ ,  $I_C = I_{CO}$ . This reverse saturation current remains constant and is independent of collector voltage  $V_{CB}$  as long as  $V_{CD}$  is below the breakdown potential.

#### Saturation region:

The region to the left of ordinate  $V_{CB} = 0$  is called the saturation region. In this region both junction are forward biased.

#### Cut-off region:

The region below the  $I_E = 0$  characteristics, for which the emitter and collector junction both reverse biased is called cut-off region.

## COMMON EMITTER CHARACTERISTICS:

Fig. shows the circuit employed for determining transistor common emitter characteristics.

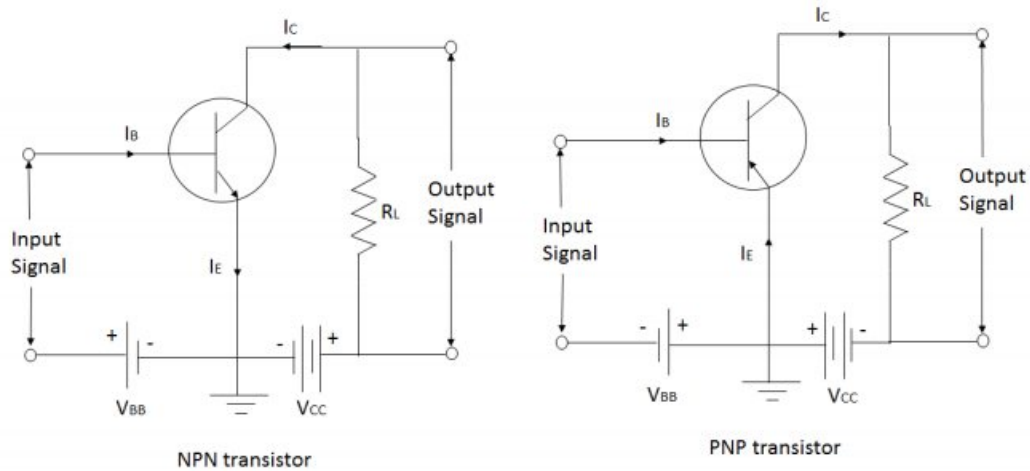

In this configuration, the input is applied between the base and the emitter and the output is taken from the collector and the emitter. In this connection, the common emitter is common to both the input and the output circuits as shown in fig. In the common emitter configuration, the input current is the base current  $I_B$  and the output current is the collector current  $I_C$ . The ratio of change in collector current to the change in base current at constant collector-emitter voltage is called current amplification factor ( $\beta$ ).

$$\beta = \frac{\Delta I_C}{\Delta I_B} \text{ at constant } V_{CE}$$

### Common Emitter Circuit:

A test circuit for determining the static characteristics of an NPN transistor is shown in fig. In this circuit emitter is common to both input and output circuits. To measure the base and collector current milli ammeters are connected in series with the base and the output circuits. Voltmeters are connected across the input and the output circuits to measure  $V_{BE}$  and  $V_{CE}$ . There are two potentiometers  $R_1$  and  $R_2$  to vary the supply voltages  $V_{CC}$  and  $V_{BB}$ .

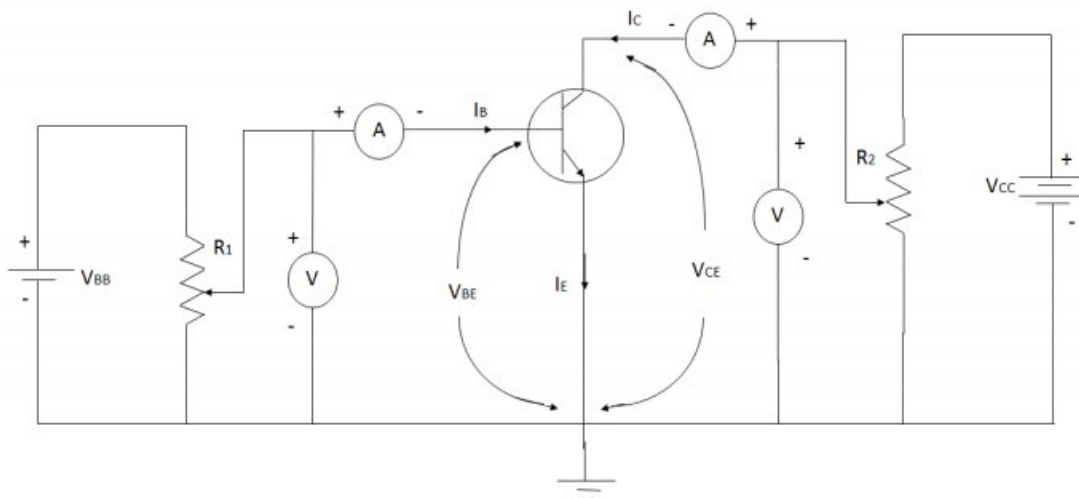

## Input Characteristics:

It is a curve, which shows the relationship between the base current  $I_B$  and the emitter-base voltage,  $V_{BE}$  at constant  $V_{CE}$ . The method of determining the characteristic is as follows.

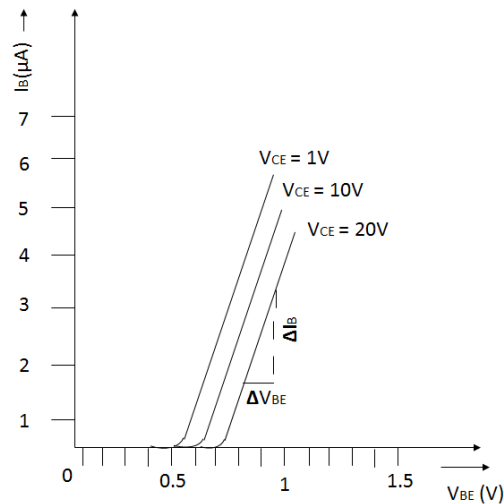

First, by means of R1 suitable voltage is applied from  $V_{CC}$ . Next, voltage  $V_{BE}$  is increased in number of steps and corresponding values of  $I_B$  are noted. The base shows the input characteristic for common emitter configuration. The following points may be noted from the characteristic.

1. The input resistance of the transistor is equal to the reciprocal of the slope of the input characteristic curve

$$r_i = \frac{\Delta V_{BE}}{\Delta I_B}$$

2. The initial portion of the curve is not linear
3. The input resistance varies considerable from a value of 4-Kilo ohm to a value of 600 ohms
4. In the case of silicon transistor, the curves break away from zero current for voltage in the range of 0.5 to 0.6 volt whereas for germanium transistor the breakaway point in the range 0.1 to 0.2V.

## Output Characteristics:

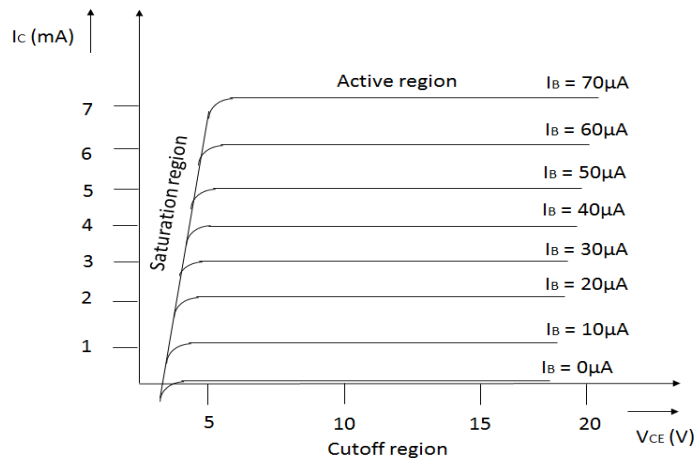



It is a curve that shows the relationship between the collector  $I_C$  and the collector-emitter voltage  $V_{CE}$ .

A suitable base current  $I_B$  is maintained.  $V_{CE}$  is increased in a number of steps from zero and the corresponding values of  $I_C$  are noted. It is repeated for different values of  $I_B$  then they are plotted as shown in the fig.

The output resistance is less than the common base configuration. It is equal to

$$r_o = \frac{\Delta V_{CE}}{\Delta I_C} \text{ at constant } I_B.$$

The following points may be noted from the family of characteristic curves.

1. The collector current  $I_C$  increases rapidly to a saturation level for fixed value of  $I_B$  but at the same time  $V_{CE}$  increases from zero.
2. A small amount of collector current flows even when  $I_B = 0$ . The current is called  $I_{CEO}$ . Now main collector current is zero and the transistor is cut-off.
3. The output characteristic may be divided into three regions.
  1. Active region
  2. Cut-off region
  3. Saturation region

**Active region:**

In this region the collector is reverse biased and the emitter is forward biased. The collector current,  $I_C$  response is the most sensitive for changes in  $I_B$ . Only in this region, the emitter acts as a linear one.

**Cut-off region:**

The region below the curve for  $I_B = 0$  is called cut-off region. In this region both junctions are reverse biased.

**Saturation region:**

The region curves to the left of line is called saturation region. In this region both the junctions are forward bias and incremental change in  $I_B$  do not produce corresponding large changes in  $I_C$ . The ratio of  $V_{CE}$  to  $I_C$  at any point in this region is called saturation region.

**COMMON COLLECTOR CONFIGURATION:**

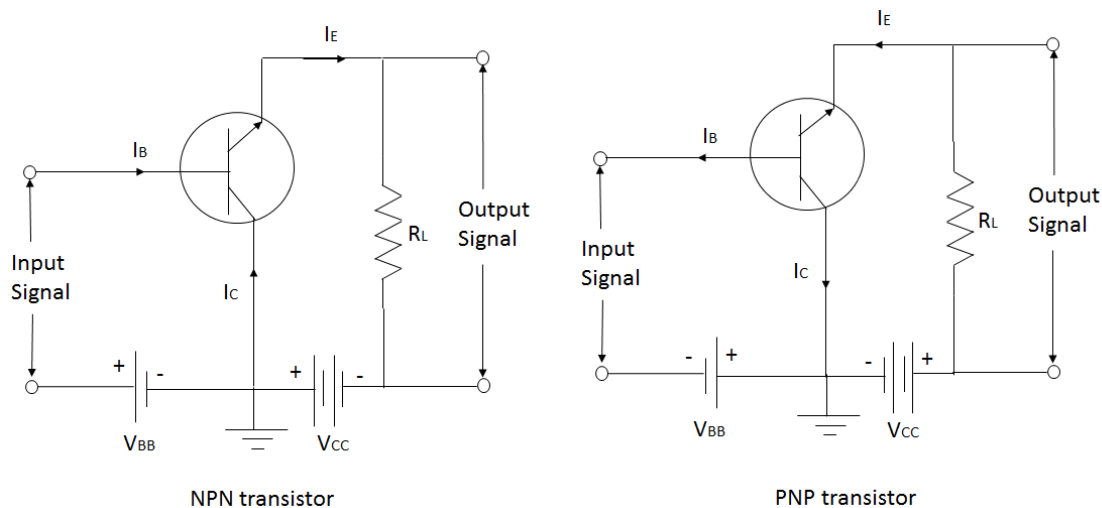

In this configuration the input is applied between the base and collector and the output is taken from the collector and the emitter and hence the collector is common to both input and the output circuits as shown in fig.

In common collector configuration, the ratio of change in output current (emitter current) to the change in the input current (base current) is called current amplification factor.

$$\Gamma = \frac{\Delta I_E}{\Delta I_B}$$

**COMMON COLLECTOR CIRCUIT:**

A test circuit for determining the static characteristic of an NPN transistor is shown in the fig. In this circuit the collector is common to both the input and the output. To measure the base and the emitter circuits, milli ammeters are connected series with the base and the emitter circuits. Voltmeters are connected across the input and the output circuits to measure  $V_{CB}$  and  $V_{CE}$ .

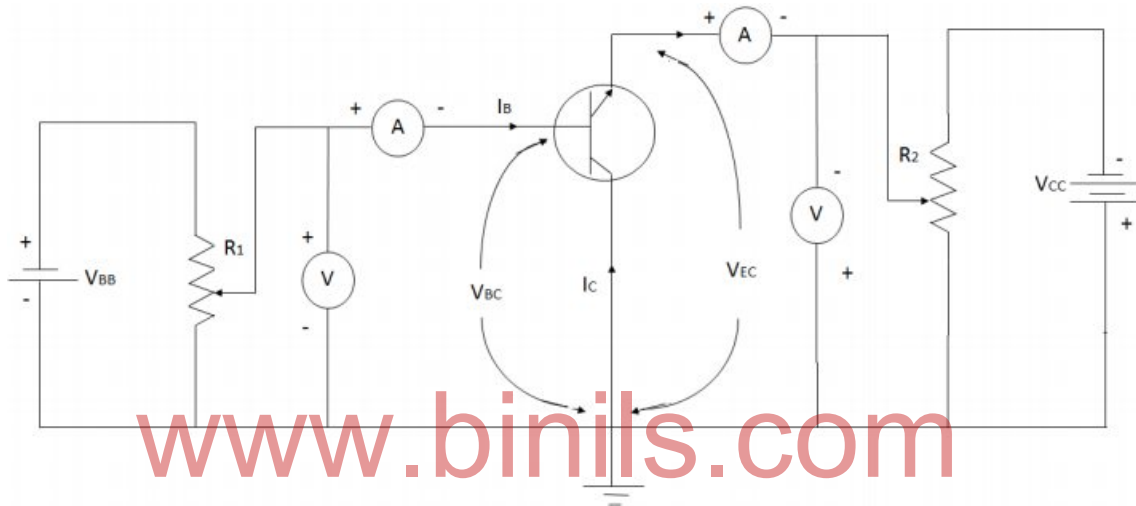

**Input characteristics:**

It is a curve, which shows the relationship between the base current,  $I_B$  and the collector base voltage  $V_{CB}$  at constant  $V_{CE}$ . This method of determining the characteristic is as follows.

First, a suitable voltage is applied between the emitter and the collector. Next the input voltage  $V_{CB}$  is increased in a number of steps and corresponding values of  $I_B$  are noted. The base current is taken on the Y-axis. Fig shows the family of the input characteristics at different collector-emitter voltages. The following points to be noted from the family of characteristics curves.

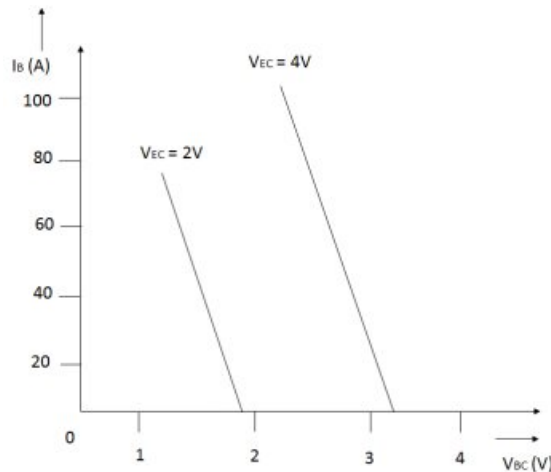

1. Its characteristics are quite different from those of common base and common emitter circuits.
2. When  $V_{CB}$  increases,  $I_B$  is decreased.

$$r_i = \frac{\Delta V_{CB}}{\Delta I_B} \text{ at constant } V_{CE}$$

### Output characteristics:

It is a curve, which shows the relationship between emitter current  $I_E$  and collector-emitter voltage,  $V_{CE}$ . The method of determining the output characteristics is as follows.

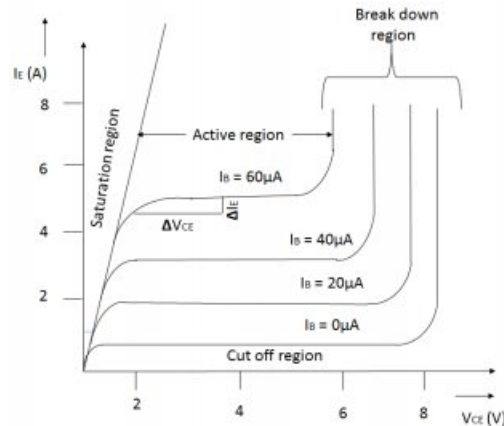

First, by adjusting the input a suitable current  $I_B$  is maintained. Next  $V_{CB}$  is increased in a number of zero and corresponding values of  $I_E$  are noted. The above whole procedure is repeated for different values of  $I_B$ . The emitter current is taken on the Y-axis and the collector-emitter voltage is taken on the X-axis. Fig shows the family of output characteristic at different base current values. The following point is noted from the family of characteristics curves.

1. This characteristic is practically identical to that of the common emitter circuit.
2. Its current gain characteristics for different identical values of  $V_{CE}$  are also similar to that of a common emitter circuit.

$$r_o = \frac{\Delta V_{CE}}{\Delta I_E} \text{ at constant } I_B$$

## IMPORTANT CHARACTERISTICS OF AN AMPLIFIER

### (i) Input impedance ( $Z_i$ ):

Input impedance of an amplifier is defined as the ratio of input voltage ( $V_i$ ) across the input terminals of the amplifiers to the input current ( $I_i$ ), keeping the output of the amplifier as open circuited.

$$Z_i = V_i / I_i$$

### (ii) Output impedance ( $Z_o$ )

Output impedance of an amplifier is defined as the ratio of output voltage ( $V_o$ ) to the output current ( $I_o$ ), keeping the input of the amplifier as open circuited.

$$Z_o = V_o / I_o$$

### (iii) Voltage gain ( $A_v$ )

Voltage gain of an amplifier is defined as the ratio of rate of output voltage ( $\Delta V_o$ ) to the rate of change of input voltage ( $\Delta V_i$ );

$$A_v = \Delta V_o / \Delta V_i$$

**(iv) Current gain (A<sub>i</sub>)**

Current gain of an amplifier is defined as the ratio of change of output current (ΔI<sub>o</sub>) to the rate of change of input current (ΔI<sub>i</sub>);

$$A_i = \Delta I_o / \Delta I_i$$

**(V) Power gain (A<sub>p</sub>)**

Power gain of an amplifier is defined as the ratio of rate of change outputpower (ΔP<sub>o</sub>) to the rate of change of input (ΔP<sub>i</sub>).

$$A_p = \frac{\Delta P_o}{\Delta P_i}$$

It is also equal to the product of voltage gain and current gain.

$$\text{Power gain, } A_p = A_v \times A_i.$$

**Comparison of CB, CE, CC Configurations:**

S.No	Characteristics	CB	CE	CC
1.	Input impedance	Low	Medium	High
2.	Output impedance	High	Medium	Low
3.	Current gain	Low	High	High
4.	Voltage gain	High	High	High
5.	Power gain	Medium	High	Low
6.	Phase reversal	No	Yes	No
7.	Application	AF Amplifiers	Voltage & Power amplifiers	Impedance matching

www.binils.com

**CLASSIFICATION OF AMPLIFIERS:**

Amplifiers may be classified in several ways such as:

1) On the basis of **Transistor configuration** used:-

CE, CB, CC amplifiers

2) On the basis of **active device** used:-

BJT & FET amplifiers

3) On the basis of **output of amplifiers**:-

Voltage amplifiers & Power amplifier

4) On the basis of **frequency range of operation**:-

DC amplifiers (0 to 10 Hz), Audio frequency amplifiers (20Hz to 20 KHz) & Radio frequency amplifiers (few KHz to hundred of Mhz)

5) On the basis of **input of amplifiers**:-

Small signal and large signal amplifiers

6) On the basis of **number of stages**:-

Single stage & Multistage amplifiers Multi Stage Amplifiers –(i)RC coupled (ii) Direct coupled (iii)LC coupled (iv)Transformer

7) On the basis of **mode of operation**:-

Class A, Class B, Class AB, Class C

8) On the basis of **Bandwidth**:-

Narrow band amplifiers (RF or Tuned), Wide band amplifiers (Video amplifiers)

### RC COUPLED AMPLIFIER:

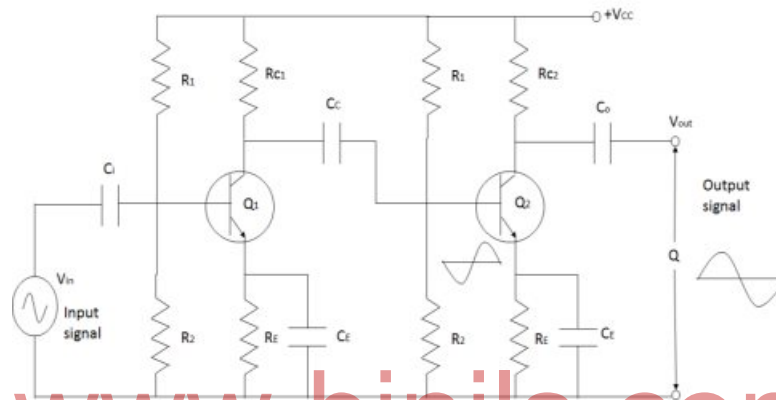

A two stage RC coupled CE amplifier using NPN transistor is shown in the fig. It is a most popular type of coupling because it is cheap and provides excellent operation.

#### Function of each component:

- $R_C$  ( $R_{C1}$  and  $R_{C2}$ ) is the collector load resistor.
- $R_1$ ,  $R_2$  and  $R_E$  provide biasing and stabilization.
- $C_E$  prevents the loss of amplification due to negative feedback.
- The capacitors  $C_i$  and  $C_o$  are used to block the DC signal and transmit only AC signal.
- The capacitor  $C_c$  is used to connect the output (collector) of first stage to the input (base) of second stage.

#### Circuit operation:

- When an AC signal is applied to the base of the first transistor ( $Q_1$ ) it appears in the amplified form across its collector load resistor  $R_{C1}$ .
- This amplified signal is given to the base of next stage through coupling capacitor  $C_c$ . The second stage does further amplification of the signal.
- The first stage produces  $180^\circ$  shift and the second stage produces another  $180^\circ$  phase shift. So the total phase shift is  $360^\circ$ . Hence the output signal is in phase with the applied input signal.

**NOTE:** The reason for the phase shift in each stage is CE configuration is used in the given circuit.

The overall gain of this amplifier is equal to the product of the gain of two stages. The influence of the capacitors used in this circuit, reduces the overall gain of the amplifier at low and high frequency ranges. The gain is high and constant, only at mid frequency ranges.

**Frequency response:**

An amplifier should operate irrespective of the frequency of the input signal. But practically an amplifier does not magnify all frequency range of input signal with an equal amount. Practically, by using the reactive components, the gain will be decreased at low and high frequency ranges and constant only at mid frequency ranges. This behavior of the amplifier is briefly explained below.

NOTE: To study the all frequency ranges concept, the following formula is used.  
 $X_c = 1/2\pi fC$ , Where,  $X_c$  – Reactance of coupling capacitor  $C_c$ .

**Low frequency range:**

At low frequencies, the reactance of coupling capacitor  $C_c$  is quit high and hence very low amount of signal will pass from first stage to the second stage. So gain will be reduced. Similarly, the reactance of the bypassing capacitor  $C_E$  is very high;hence it cannot shunt the emitter resistor  $R_E$  effectively.

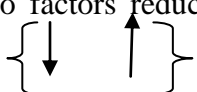
These two factors reduce the voltage gain of the amplifier at low frequency range.  $f, X_c$  

**High frequency range:**

At high frequencies the reactance of the coupling capacitor is very low. Hence it behaves as a short circuit. This increases the loading effect of next stage.

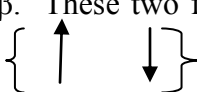
Similarly, at high frequencies the reactance of bypassing capacitor  $C_E$  is very low which increases the base current. This reduces the current amplification factor  $\beta$ . These two factors reduce the voltage gain of the amplifier at high frequency range.  $f, X_c$  

**Mid frequency range:**

At mid frequencies the voltage gain of the amplifier is constant. At this range the effect of coupling capacitor is to maintain a uniform voltage gain.

In this range as the frequency increases, the reactance of  $C_c$  decreases which tends to increase the voltage gain. However, at the same time, lower reactance means higher loading of the first stage tends to decrease the voltage gain. These two factors almost cancel each other, resulting in a uniform gain at mid frequency range.

**Frequency response:**

The curve which shows the variations of magnitude of gain with respect to frequency is called Frequency response.

**Frequency response characteristics (Load characteristic analysis):**

The frequency response characteristics of a two stage RC coupled amplifier is shown in the fig. The gain is reduced at low and high frequency ranges, and constant only at mid frequency range. From the response curve we will calculate lower cut off frequency ( $f_L$ ), upper cut off frequency ( $f_U$ ) and Bandwidth (BW).

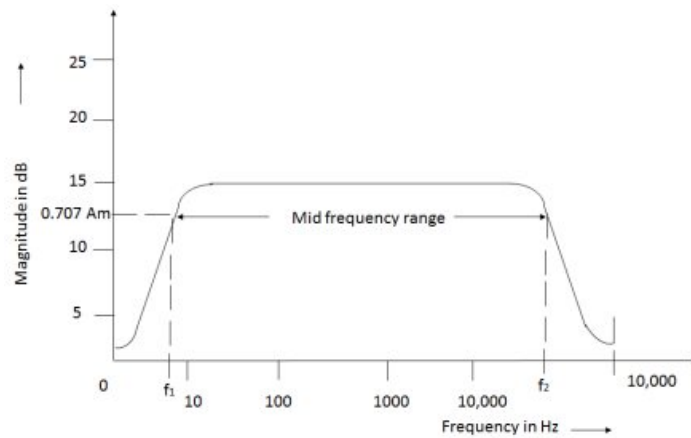

### Lower cut off frequency ( $f_L$ ):

The frequency at which the voltage gain of the amplifier is 70.7% of maximum gain (average gain) on lower side of the frequency range is called lower cut off frequency ( $f_L$ ).

### Upper cut-off frequency ( $f_U$ ):

The frequency at which the voltage gain of the amplifier is 70.7% of maximum gain (average gain) on the higher side of the frequency range is called upper cut off frequency ( $f_U$ ).

### Bandwidth (BW)

The range of frequency over which the gain is equal to or greater than 70.7% of maximum gain is known as Bandwidth.

It is also defined as the frequency difference between the upper cut-off frequency and lower cut-off frequency.

### Advantages:

- (i) Frequency response is excellent
- (ii) Cost is low
- (iii) Non-linear distortion is low
- (iv) It is compact, light and small

### Disadvantages:

- (i) Low voltage gain and power gain
- (ii) Noise is produced with age, particularly in moist climates.
- (iii) Impedance matching is poor.

### Emitter follower:

Common collector amplifier is called emitter follower. The emitter follower is a current amplifier that has no voltage gain. Its most important characteristic is that it has high input impedance and low output impedance. Hence it is an ideal circuit for impedance matching. The circuit of an emitter follower is shown in the fig.

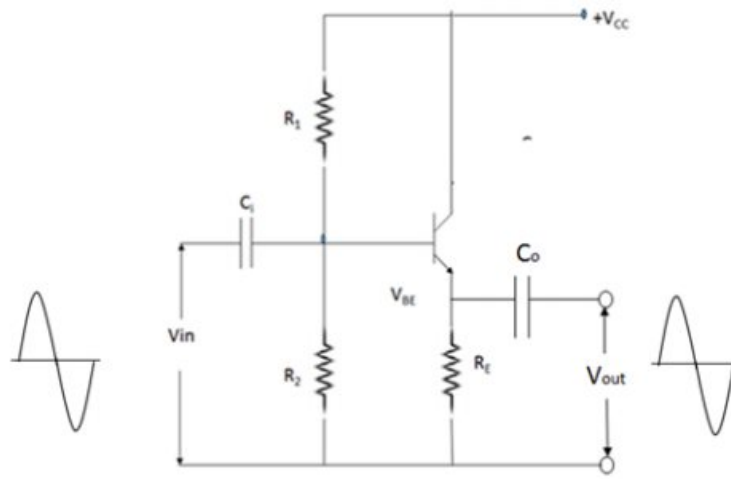

The emitter resistor  $R_E$  itself acts as a load and the ac output voltage is taken across  $R_E$ . The resistors  $R_1$  and  $R_2$  provide for proper biasing. The input and output capacitors ( $C_i$  and  $C_o$ ) block dc signals, and allow only ac signals.

The input signal is applied between base and emitter terminals. The output voltage is taken across  $R_E$ . The voltage drop across  $R_E$  opposes the input voltage, thus providing negative feedback. It is a negative current feedback circuit, since the voltage feedback is proportional to the emitter current (output current).

During conduction, the voltage drop across base-emitter ( $V_{BE}$ ) is very low, hence  $V_{in} = V_{out}$ . The output (emitter) signal follows the input signal in phase, amplitude and frequency. So it is called emitter follower.

**Characteristics of Emitter follower:**

1. Voltage gain is nearly equal to unity
2. High current gain and power gain
3. High input impedance and low output impedance
4. Input and output ac voltages are in phase.

**Application of EmitterFollower:**

**Current amplification without voltage gain:**

Emitter follower is a current amplifier that has no voltage gain. There are many instances, where an increase in current is required but no increase in voltage is needed. In such a situation, an emitter follower can be used. For example, consider the two stage amplifier circuit as shown in the fig. Suppose this 2 stage amplifier has the desired voltage gain but current gain of this multistage amplifier is insufficient. In that case, we can use an emitter follower to increase the current gain without increasing the voltage gain.

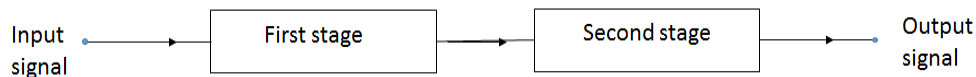



## Impedance Matching

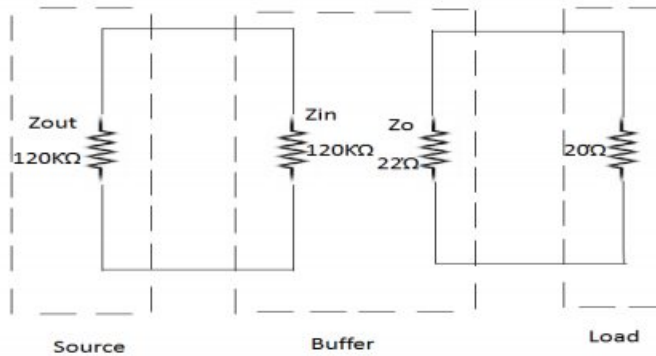

The emitter follower has high input impedance and low output impedance. This makes the emitter follower an ideal circuit for impedance matching. The fig shows the impedance matching by an emitter follower. Here, the output impedance of the source is  $120\text{K}\Omega$  while that of load is  $20\Omega$ . The emitter follower has an input impedance of  $120\text{K}\Omega$  and output impedance of  $22\Omega$ . It is connected between high impedance source and low impedance load. The net result of this arrangement is that maximum power is transferred from the original source to the original load. When an emitter follower is used for this purpose it is called a buffer amplifier.

### Feedback:

The process of injecting a fraction of output signal of some device back to the input is called feedback.

There are two types of feedback, namely

1. Positive feedback
2. Negative feedback

### Positive feedback:

When the feedback signal (voltage or current) is in phase with the input signal, it is called positive feedback. In this feedback, the feedback signal aids the input signal, increases the amount of input signal and the gain also increases. Hence it can be called regenerative or direct feedback. It is generally used in oscillator circuits.

### Negative feedback

When the feedback signal (voltage or current) is out of phase with the input signal, it is called negative feedback. In this feedback, the feedback signal opposes the input signal, decreases the amount of input of input signal, and the gain also decreases. Hence it can be also called degenerative or inverse feedback. It is generally used in amplifiers.

## GENERAL THEORY OF FEEDBACK:

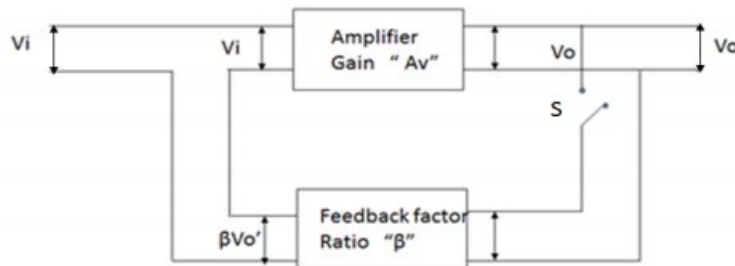

The block diagram of an amplifier with feedback is shown in the fig. When switch 'S' is open, the amplifier operates without any feedback network. Now the gain of an amplifier

$$\text{Without feedback, } A_v = \frac{V_o}{V_i}$$

Where,

$V_o$  = voltage of output signal without feedback

$V_i$  = voltage of input signal without feedback

When switch 'S' is closed, the amplifier operates with feedback network. Now the output voltage is varied from  $V_o$  to  $V_o'$ .

The output voltage of feedback network,  $V_f = \beta V_o'$

The actual voltage developed at the input of the amplifier with feedback =  $V_i + \beta V_o'$

The output voltage with feedback =  $V_o'$

$$V_o' = A_v V_i$$

$$V_o' = A_v (V_i + \beta V_o')$$

$$V_o' = A_v V_i + A_v \beta V_o'$$

$$V_o' - A_v \beta V_o' = A_v V_i$$

$$V_o' (1 - A_v \beta) = A_v V_i$$

From this equation, the gain of feedback amplifier,

$$A_{vf} = \frac{V_o'}{V_i} = \frac{A_v}{1 - \beta A_v}$$

The term ' $\beta A_v$ ' is called feedback factor. The expression  $(1 - \beta A_v)$  is called loop gain. The sign of  $\beta$  is positive for positive feedback and negative for negative feedback.

Hence the gain of positive feedback amplifier,

$$A_{vf} = \frac{A_v}{1 - \beta A_v}$$

The gain of negative feedback amplifier,

$$A_{vf} = \frac{A_v}{1 - (-\beta)A_v} = \frac{A_v}{1 + \beta A_v}$$

Thus in positive feedback,  $A_{vf} > A_v$ , gain increases. In negative feedback,  $A_v > A_{vf}$ , gain decreases.

### Effect of negative feedback:

1. Increases the input impedance by the factor of  $(1 + A_v \beta)$
2. Decreases the output impedance by the factor of  $(1 + A_v \beta)$
3. Increases the stability
4. Reduces the distortion like harmonic distortion, frequency distortion and phase distortion
5. Reduces the noise and increases the bandwidth.

## Types of negative feedback connections:

1. Series Voltage Feedback
2. Series Current Feedback
3. Shunt Voltage Feedback
4. Shunt Current Feedback

### 1. Series Voltage Feedback:

Figure shows the schematic diagram of the voltage series feedback. Here a portion of the output voltage is returned to the input in series, and opposing the applied signal.

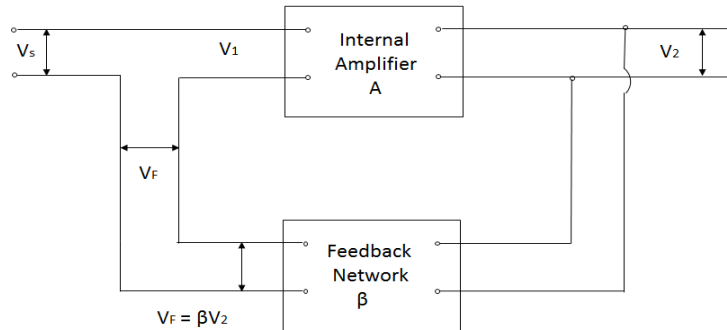

### Salient features of series voltage feedback:

1. Improves the stability of voltage gain.
2. Frequency distortion decreases.
3. Non-linear distortion decreases.
4. Reduced noise.
5. Increased bandwidth.
6. Output resistance decreases, and input resistance increases.

### 2. Series current Feedback:

Figure shows the series current feedback amplifier. In this type of feedback, a voltage proportional to the output current is returned to the input, in series opposition to the applied signal.

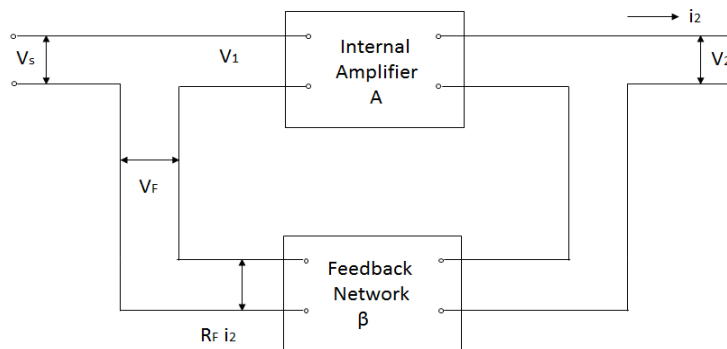

### Salient features of series current feedback:

1. Improves the stability of mutual conductance.
2. Frequency and non-linear distortion decreases.
3. Reduced noise.
4. Bandwidth increases.
5. Input resistance increases.

### 3. Shunt voltage Feedback:

Figure shows the schematic diagram of a shunt voltage feedback amplifier. Here a portion of the output voltage is returned to the input, in parallel with the input voltage. Then this kind of feedback is called as voltage shunt feedback. Here the output voltage is more than 180 degree out of phase with the input voltage.

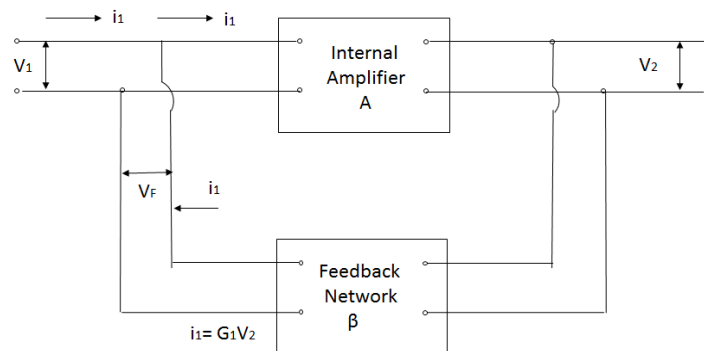

### Salient features of shunt voltage feedback:

1. Improves the stability of mutual resistance.
2. Frequency distortion and non-linear distortion decreases.
3. Reduced noise, bandwidth decreases, output resistance decreases and input resistance decreases.

### 4. Shunt current Feedback:

Figure shows the schematic diagram of a shunt current feedback. Here the feedback is negative.

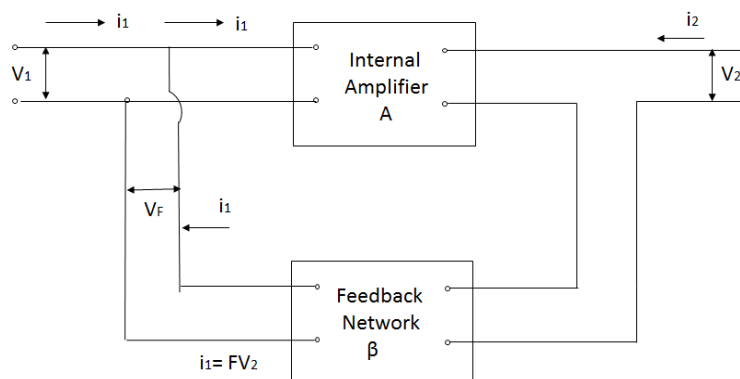

**Salient features of shunt current feedback:**

1. It improves the stability of current gain.
2. Frequency distortion decreases and non-linear distortion decreases.
3. Noise decreases, Bandwidth increases.
4. Output resistance increases and input resistance decreases.

[www.binils.com](http://www.binils.com)

## UNIT III

### TRANSISTOR OSCILLATORS AND FET AND UJT

#### OSCILLATORS:

Many electronic devices require a source of energy at a specific frequency, which may range from few Hz to several MHz. This is achieved by an electronic device called oscillator.

#### Definition:

Oscillator is an electronic device which generates an AC signal with required frequency, required amplitude and required wave shape. In radio and television receivers, oscillators are used to generate high frequency carrier signals. Oscillators are widely used in radars, electronic equipment and other electronic devices.

Oscillators are broadly classified into two types.

They are

- 1) Sinusoidal oscillators
- 2) Non-sinusoidal oscillators (Relaxation oscillators)

The sinusoidal oscillators are used for generating only sinusoidal signals with required frequency and required amplitude. The non-sinusoidal oscillators are used for producing non-sinusoidal signals like square, rectangular, triangular, or saw tooth signals with required amplitude and required frequency.

#### CLASSIFICATION OF OSCILLATORS:

Oscillators are classified into the following different types

- (a) According to the wave form generated
  - (1) Sinusoidal oscillators  
LC oscillators, and  
RC oscillators
  - (2) Non-sinusoidal oscillators (Relaxation oscillators)  
Square wave, rectangular wave, saw tooth etc.
- (b) According to the fundamental mechanism used
  - (1) Negative resistance oscillators
  - (2) Feedback oscillators
- (c) According to the frequency generated
  - (1) Audio Frequency (AF) oscillators
  - (2) Radio Frequency (RF) oscillators
  - (3) Very High Frequency (VHF) oscillators
  - (4) Ultra High Frequency (UHF) oscillators
  - (5) Microwave oscillators

#### Basic Theory of Oscillator:

A circuit which produces electrical oscillations of any desired frequency is known as an Oscillatory circuit or tank circuit. An amplifier uses a positive feedback. The feedback is a property, which allows to feedback the part of the output, to the same circuit as its input. Such a feedback is said to be positive whenever the part of the output that is feedback in the amplifier as its input, is in phase with the original input signal applied to the amplifier.

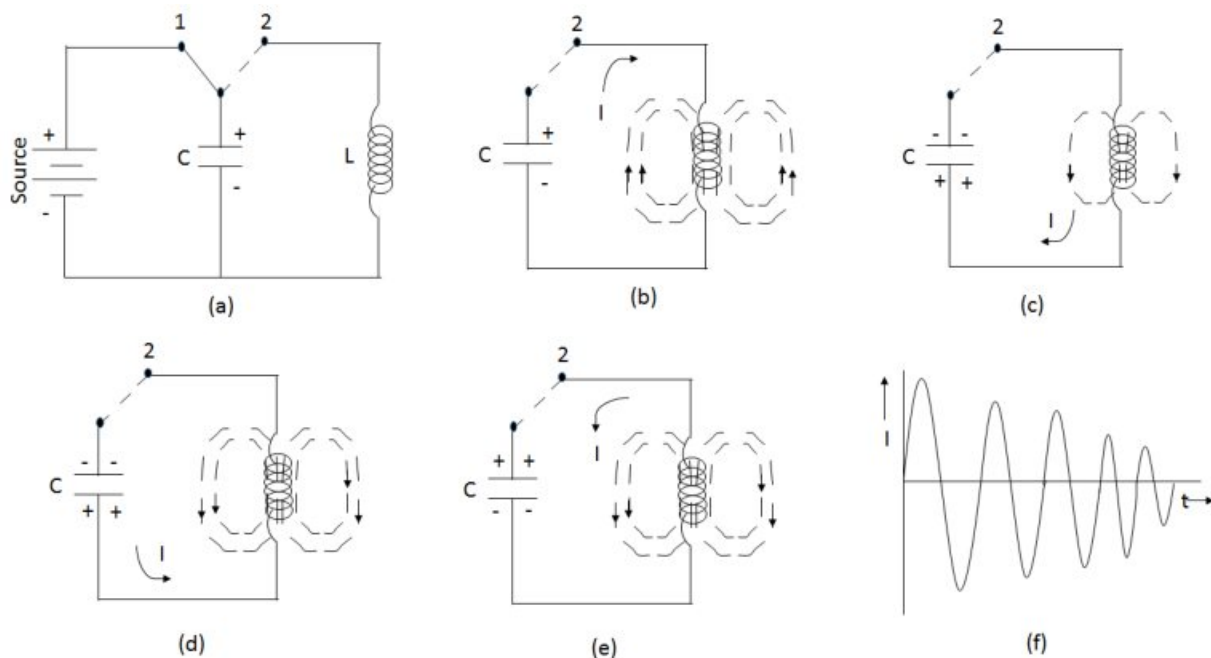

Now, if the switch S is changed to position 2, as shown in fig b. the capacitor will discharge through the inductor and the current flow will be in the direction indicated by the arrow. The current that passes through the inductor will set magnetic field around the coil. Due to the inductive effect of the coil, the current through the coil increases slowly and attains the maximum. Thus the electrostatic energy across the capacitor is totally transferred to inductance as magnetic energy. Now the capacitor is fully discharged.

When the capacitor is fully discharged, the magnetic field, in the inductance will collapse and produce counter e.m.f. As per the lenz's law, the counter e.m.f will charge capacitor in the opposite direction (upper plate as negative and lower plate as positive).

Finally the magnetic field is completely collapsed and the capacitor is fully charged as shown in fig C. Now once again an electrostatic energy is established across capacitor discharges by transferring energy to inductor. Thus the capacitor will discharge through the inductor and the current flows through the inductor will be in the direction as indicated by the arrow, which is opposite to the figure b. It is shown in fig d.

Again the energy from the inductor is transferred to capacitor is empty now. It is shown in fig e.

The charging and discharging result in alternating motion of current through the inductor. If there were no loss of energy in the component, the oscillating current would continue and we can obtain oscillation continuously. But due to energy conversion from one to another, there will be losses. So, the amplitude of oscillating current decreases gradually and it became zero after some time. Therefore, the oscillation produced by the tank circuit is by nature a damped one.

The frequency of oscillation of the tank circuit is calculated as follows:

Since capacitor C and inductance L are in parallel, voltages across them are equal

$$\text{i.e. } IX_L = IX_C \quad \text{or} \quad X_L = X_C$$

$$\text{i.e. } 2\pi fL = 1/2\pi fC$$

$$f^2 = 1/4\pi^2 LC$$

$$f = 1/2\pi\sqrt{LC}$$

**Transistor Amplifier:**

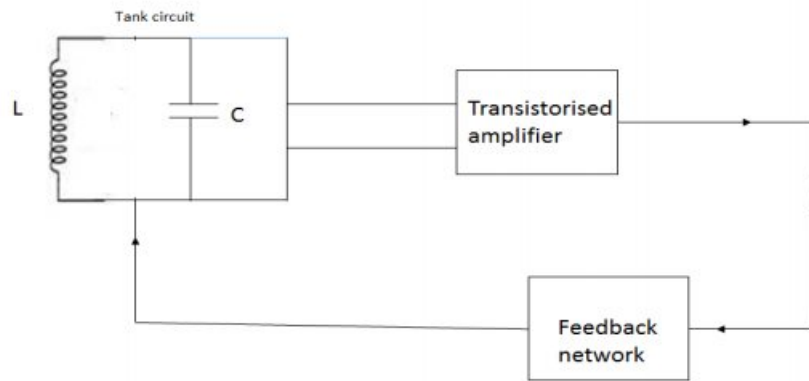

In order to make the oscillations undamped, it is necessary to supply the required quantity of energy at the proper time intervals to the tank circuit to meet out the losses. Using a transistor does this. First of all DC power is converted into AC and then it is supplied to the tank circuit. The damped oscillating current is applied to the base of the transistor and so, the amplifier damped oscillating current is formed in the collector. Now more energy is available in the collector than the base of the transistor. Then due to feedback network a part of the output, is fed to the base circuit in proper phase to aid the oscillation in the tank circuit. Thus the losses are overcome and undamped oscillations are produced.

**Feedback circuit:**

The type of feedback used in oscillator circuit is positive feedback. It feeds a part of collector energy to the tank circuit in correct phase to aid the oscillations. The essential for maintaining oscillations and finding out the value of frequency are all deduced from it.



**Barkhausen criterion : ( condition for oscillations):**

A Barkhausen criterion is the statement, which gives the essential condition for maintaining self sustained oscillation. An oscillator system consists of an amplifier with gain of 'A' and a feedback circuit with a gain of  $\beta$ .

Let  $V_1$  be the input signal.  $V_0$  be the output signal and  $V_{fd}$  be the feedback signal. Consider in the fig.

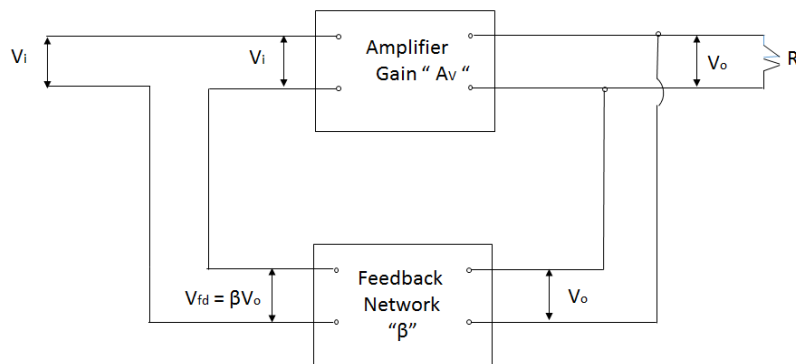

Gain,  $A = V_0 / V_i$                        $V_0 = A V_i \dots \dots \dots (1)$

Feedback signal,  $V_{fd} = \beta V_0 \dots \dots \dots (2)$

For self-maintaining oscillation there is no separate input but feedback itself is equal to input.

$V_1 = V_{fd}$



i.e.  $V_1 = \beta V_0$

From equation (1)  $V_0 = A \beta V_0$

i.e.,  $V_0/V_0 = A \cdot \beta \dots\dots\dots (3)$

**$1 = A \cdot \beta$**

i.e.  $A \beta = 1$  is the expression for self-maintaining oscillation which is called Barkhausen criteria.

From the above expression we can arrive the condition for oscillation.

1.  $A \beta = 1$  i.e. closed loop gain must be unity.
2. Total loop phase shift must be  $0^\circ$  or integral multiples of  $2\pi$ . i.e.  $0^\circ, 360^\circ, 720^\circ$  etc.

**Types of sinusoidal feedback oscillators:**

There are two types of sinusoidal feedback oscillators. They are a) LC resonant circuit oscillators and b) RC phase shift oscillators. LC resonant oscillators are further classified into

1. Tuned collector oscillator.
2. Hartley oscillator and
3. Colpitt's oscillator.

**Hartley oscillator:**

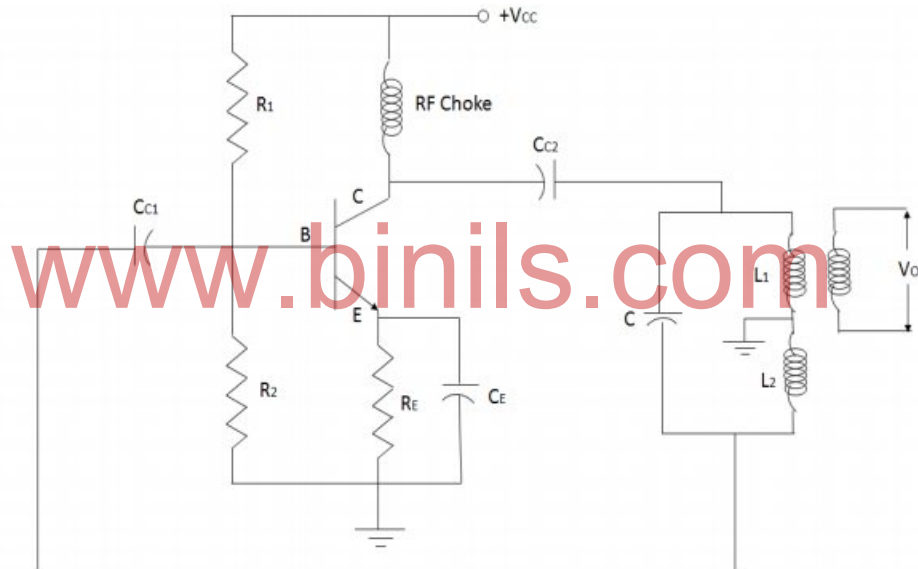

Figure shows the Hartley oscillator. The tank circuit is made up of C, L1 and L2. The coil L1 is inductively coupled to L2. Hence the combination L1 and L2 functions as auto transformer. The resistance R1 and R2 provide the necessary base biasing. The capacitor C blocks the DC component. The RF choke provides a path for collector bias current but offers higher impedance for oscillating signal. The voltage developed across L1 is coupled by Cc to the base of transistor. Another capacitor Cc is used to couple the output signal to primary winding of transformer. The actual output is taken from secondary winding of transformer.

**Circuit operation:**

When the supply is switched ON, collector current starts rising and charges the capacitor C in the tank circuit. When the capacitor is fully charged, it discharges through the coils L1 and L2 and initial

oscillations are produced. The induced oscillations across L2 are applied between the base and emitter terminal of the transistor then it is amplified and appears in the collector circuit.

The coil L1 couples the collector circuit energy into the tank circuit by means of mutual inductance between L1 and L2. The coil in the tank circuit, and transistor, each provides 180° phase reversal and so a total phase shift of 360° is produced between the output and the input. This results in positive feedback to overcome the losses occurring in the tank circuit. Therefore a continuous undamped oscillation will be obtained at the output.

The frequency of the oscillation is given by

$$f = 1/2\pi\sqrt{LC}$$

Where,  $L = L_1 + L_2$  (Inductors are connected in series in the tank circuit.)

**Advantages:**

1. Easy to tune
2. Can be adopted for a wide range of frequencies.

**Applications:**

1. Used as a local oscillator in radio receiver.
2. Used in audio oscillator circuits.

**Colpitt's oscillator:**

The Colpitt's oscillator is the same as Hartley oscillator. The major difference between the two is that the Colpitt's oscillator uses tapped capacitors whereas Hartley oscillator uses tapped inductance.

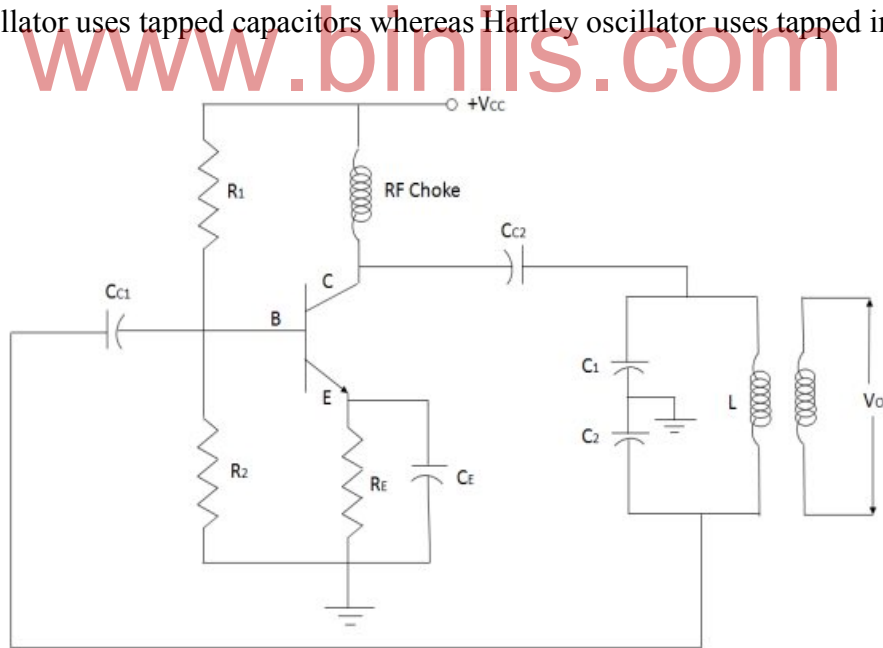

Figure shows the Colpitt's oscillator. The tank circuit is made up of C1, C2 and L. The resistances R1 and R2 provide base bias and RE and CE provide stabilization. The RF choke coil provides path for collector bias current but offers very high impedance for high frequency signal. The frequency of oscillation is given by

$$f = 1/2\pi\sqrt{LC},$$

Where,  $C = C_1 C_2 / C_1 + C_2$  (Capacitors are connected in series in the tank circuit.)

### Circuit operation:

When the supply is switched ON, capacitors  $C_1$  and  $C_2$  are charged. Then these capacitors discharge through coil L and so, initial oscillations are generated. The oscillations across  $C_2$  are applied to the base emitter junction of the transistor. This is amplified and available in the collector circuit. The amplified power from collector is applied to the tank circuit to meet out the losses during energy conversation between capacitors  $C_1$  and  $C_2$  and inductance L.

The amount of feedback depends upon the value of capacitance  $C_1$  and  $C_2$ . The transistor amplifier provides  $180^\circ$  phase shift and the capacitor feedback provides another  $180^\circ$  phase shift. Hence totally there will be a phase shift of  $360^\circ$  which provides positive feedback. Therefore, continuous undamped oscillations are generated.

### Applications:

1. Used in signal generators
2. Used in super heterodyne radio receivers as local oscillators.

### RC oscillators:

Hartley, colpitt's, tuned collector all use LC tuned circuits. These tuned circuits oscillators are good for generating high frequencies (SAY, audio frequency) the LC circuit becomes impracticable. RC oscillators are more suitable.

### RC phase shift oscillator:

The LC oscillators have two general drawbacks

- (i) It cannot be used for very low frequencies, because the coil becomes too much bulky, expensive and noisy.
- (ii) The frequency stability and waveforms are very low.

The RC oscillators produce good frequency stability and also operate at very low frequencies.

The circuit diagram of RC phase shift oscillator is shown in the fig. The oscillators consist of three stages networks ( $R_1C_1$ ,  $R_2C_2$  and  $R_3C_3$ ). The resistor  $R_5$  provide base bias, and  $R_E$  with  $C_E$  provides stabilization. The frequency of the oscillation is given by

$$F = \frac{1}{2\pi\sqrt{6} RC}$$

Where  $R = R_1 = R_2 = R_3$  and  
 $C = C_1 = C_2 = C_3$

### Principle of operation:

When the supply is switched ON, the random variations of base current caused by noise variations in the transistor and voltage variations in the power source produce oscillation. This variation is amplified by the CE amplifier.

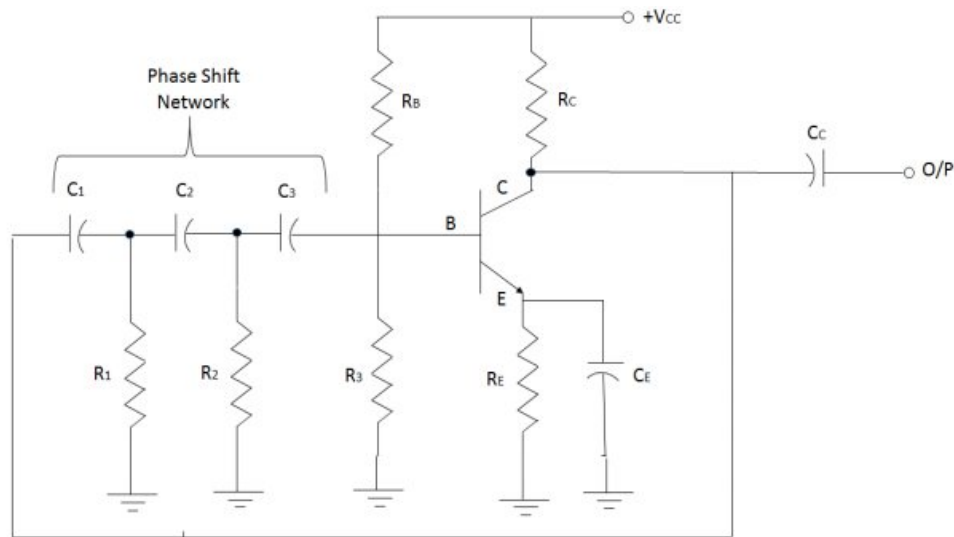

The feedback network consists of three stages of RC networks. The three stages are identical. The feedback section provides  $180^\circ$  phase shift because each RC network provides  $60^\circ$  phase shift ( $3 \times 60^\circ = 180^\circ$ ). The CE amplifier provides another  $180^\circ$  phase shift. Hence the total shift is  $360^\circ$ , which provides positive feedback. Therefore, continuous undamped oscillation is produced.

**Advantages:**

- (i) Does not require transformers and inductors
- (ii) It can produce very low frequency signals
- (iii) The circuit provides good frequency stability.

**Disadvantages:**

- (i) It is difficult to start oscillation
- (ii) It gives low power output
- (iii) This RC oscillator is not suitable for tuned oscillator because the variations of capacitor and resistor values also changed the phase shift of the RC networks.

www.binils.com

**CRYSTAL OSCILLATOR:**

Due to the following effects, the LC and RC oscillators do not produce more stable oscillations,

- (i) The value of R, L and C which are frequency determining factors in these circuits, will change the temperature.
- (ii) If any component in the feedback network is changed, it will shift the operating frequency of the oscillator.

To maintain constant frequency, piezoelectric crystals are used with LC or RC oscillators (or) in the place of LC or RC circuits. Oscillators of this type are called crystal oscillators. The crystal has a peculiar property known as piezoelectric effect, which is expressed as

- (i) When mechanical stress is applied across its two faces, the crystal vibrates and an ac voltage is produced.
- (ii) When an ac voltage is applied across its crystal, the crystal vibrates at the frequency of the applied voltage.

The frequency of the vibration is equal to the resonance frequency of the crystal. The equivalent electrical circuit of the crystal is mentioned as

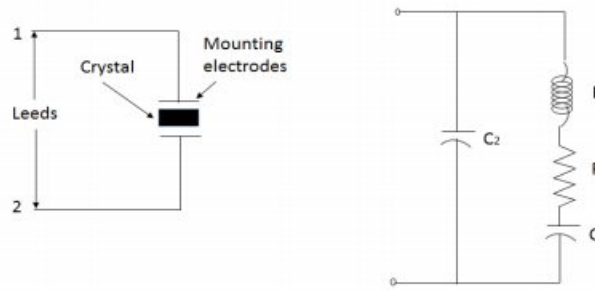

- (i) When the crystal is not vibrating, it is equivalent to the capacitance  $C_m$ , known as mounting capacitance
- (ii) When a crystal vibrates, it is equivalent to R-L-C series circuit.

The circuit diagram of a crystal oscillator is shown in the fig. It is actually a colpitts oscillator, modified into a crystal oscillator. The resistors  $R_1$  and  $R_2$  provide base bias and  $R_E$  with  $C_E$  provide stabilization.

**Principle of operation**

The natural frequency of the LC circuit is made nearly equal to the natural frequency of the crystal. When the supply is switched ‘ON’, the capacitor  $C_1$  is going to charge. When the capacitor  $C_1$  is fully charged, it discharges through crystal which produces oscillation. The frequency of the oscillation depends upon the values of  $C_1$ ,  $C_2$  and the RLC equivalent values of crystal. If the frequency of the oscillation is equal to its crystal resonant frequency, the circuit produces more stable oscillation. The crystal frequency is independent of temperature.

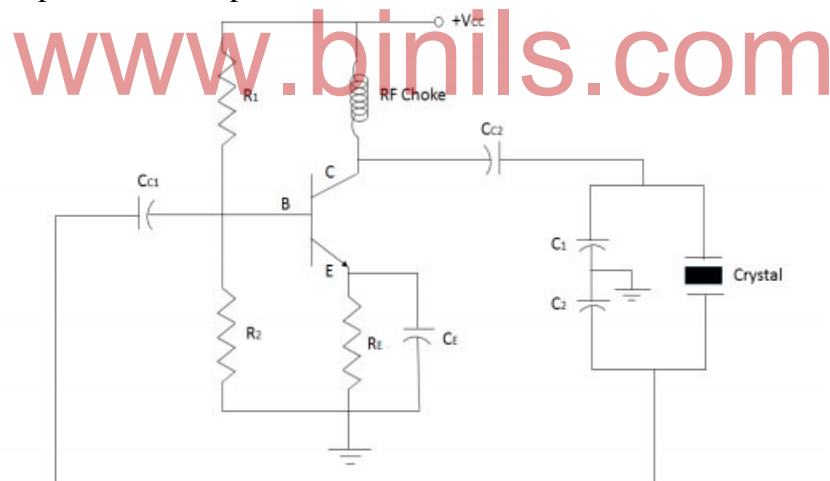

The  $C_2$  feedback network, provides  $180^\circ$  phase shift, and also the CE amplifier provides another  $180^\circ$  phase shift. Hence the total phase shift is  $360^\circ$ , which provides positive feedback. Therefore, continuous undamped oscillation is produced. A crystal oscillator always generates high frequency oscillations, range from 20 KHz to 20MHz

**Advantages:**

- 1. Excellent frequency stability.
- 2. Simple circuit.
- 3. High quality factor.

**Disadvantages:**

- 1. Crystal is fragile type; hence it is used only in low power circuits.

- Not used as tuned oscillators.

## FIELD EFFECT TRANSISTORS:

Field effect transistor (FET) is a unipolar semiconductor device. The flow of current through it is controlled by an electric field. The flow of current only depends upon the majority carriers (either electrons or holes), so the FET is called unipolar device.

Based on the construction, FETs can be classified as follows.

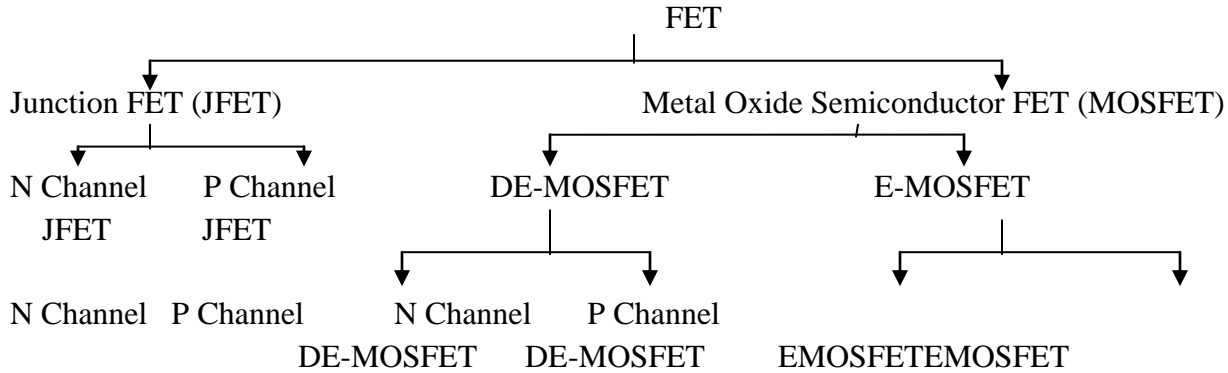

## JUNCTION FIELD EFFECT TRANSISTOR (JFET):

**N- channel JFET & its symbol P- channel JFET & its symbol**

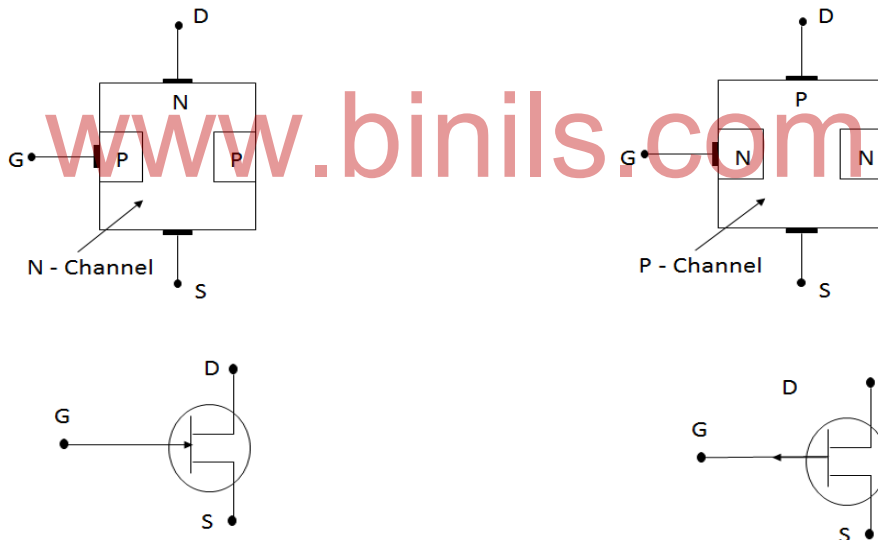

The construction of a N-channel JFET is shown in the fig. It consists of an uniformly doped N-type semiconductor bar. On both sides of the semiconductor bar, two heavily doped P-type regions are formed by diffusion. The two P-regions are internally connected, and a single lead is taken out. This terminal is called “Gate” Ohmic contacts are made at the two ends of the N-type semi-conductor bar. One terminal is called “Source” and the other is called “Drain”.

The source is a terminal, where majority carriers enter the bar. Drain is a terminal where majority carriers leave the bar. The region between source and drain is called channel. The majority carriers move from source to drain through this channel. The gate terminal controls the flow of majority carriers from source to drain.

## Working Principle of JFET:

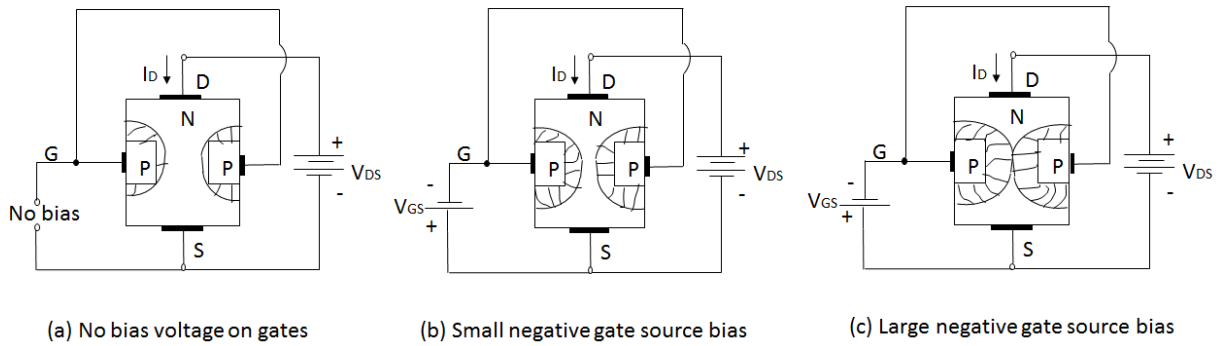

The N-channel JFET is normally biased by applying negative potential ( $V_{GS}$ ) to the gate with respect to source, is shown in the fig. A positive potential ( $V_{DS}$ ) is applied to the drain terminal with respect to source. The drain characteristics are obtained by taking the readings in between  $V_{DS}$  and  $I_D$ , with a constant variation of  $V_{GS}$ .

When  $V_{GS}=0$ , the two P-N junctions established a very thin and uniform depletion layer. Thus a large amount of electrons will flow from drain to source through a wide channel, in between the depletion region. This constitutes drain current  $I_D$ .

When the reverse voltage  $V_{GS}$  is increased, it increases the width of the depletion region. This reduces the width of the channel. So the current ( $I_D$ ) flow is also reduced. The channel width is larger in the source region than the drain region.

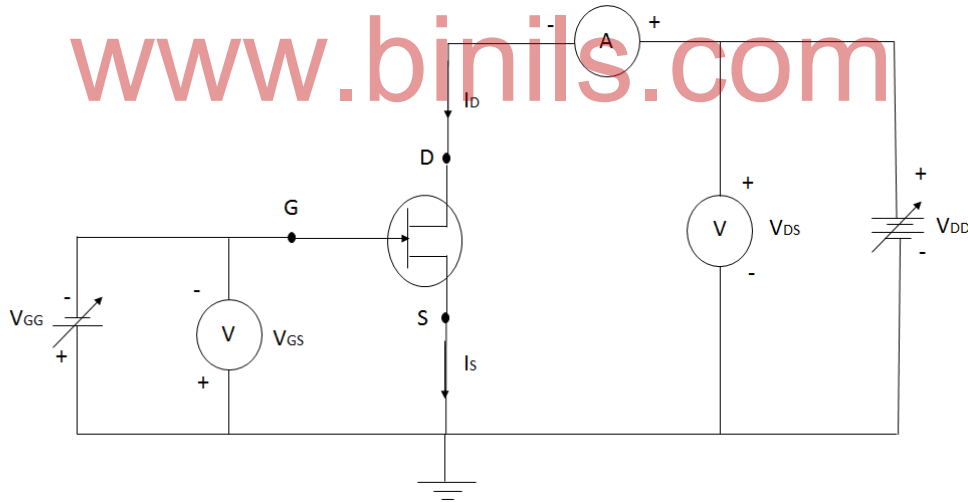

Thus the current flowing through the channel is controlled by the reverse potential applied to the gate terminal. The circuit diagram to determine the characteristics of N-channel JFET is shown in the fig.

## Drain characteristics:

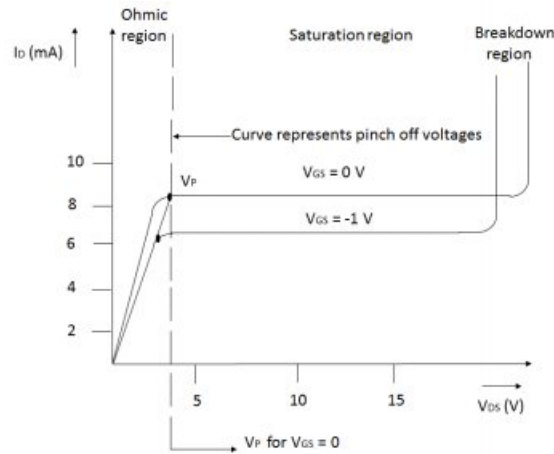

This circuit diagram is used to find out the drain and source characteristics of the JFET. The graph drawn between  $V_{DS}$  and  $I_D$  is known as drain characteristics or output characteristics. Three regions are formed in the drain characteristics; they are linear region, saturation region and breakdown region, shown in the fig.

### Linear region:

Initially as the drain to source voltage ( $V_{DS}$ ) is increased, drain current ( $I_D$ ) also increases. Such that  $I_D$  is directly proportional to  $V_{GS}$ . This region is called linear region or channel ohmic region.

### Saturation region:

After a certain drain to source voltage ( $V_{DS}$ ), the drain current ( $I_D$ ) becomes almost constant. Now the channel becomes very narrow. Therefore, the variation of drain current ( $I_D$ ) with the increasing of  $V_{DS}$  is constant. This region is called saturation region or pinch-off region. The minimum voltage, that the JFET produces the current as constant is called pinch-off voltage. In this region a FET operates as a constant current device.

### Breakdown region:

After a certain increase of  $V_{DS}$ , the drain current increases to a very high value, with a slight increase of  $V_{DS}$ . Now the depletion region at the PN junction undergo avalanche breakdown. This region is known as breakdown region.

The graph between  $I_D$  and  $V_{GS}$ , at constant  $V_{DS}$  is called transfer or mutual characteristics, shown in the fig.

When  $V_{GS}=0$ , the drain current is in higher value. The increasing of  $V_{GS}$ , increases the width of depletion region, also reduces the drain current  $I_D$ . Once the current  $I_D$  is equal to zero, because the increasing depletion region, blocks the channel.



## Transfer Characteristics

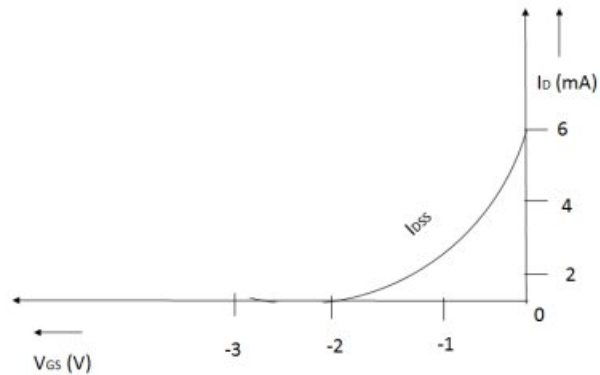

From the graph,

1. Drain resistance ( $r_d$ ) =  $\frac{\Delta V_{ds}}{\Delta I_d}$  (at constant  $V_{GS}$ )

2. Transconductance ( $g_m$ ) =  $\frac{\Delta I_d}{\Delta V_{GS}}$  (at constant  $V_{DS}$ )

3. Amplification factor ( $\mu$ ) =  $\frac{\Delta V_{ds}}{\Delta V_{GS}}$  (at constant  $I_D$ )

The relationship between  $\mu$ ,  $r_d$  and  $g_m$  is mentioned as  $\mu = r_d \cdot g_m$ .

### Applications:

1. It is used as a buffer in measuring instruments.
2. It is used in RF amplifiers of FM tuners and communication equipments.
3. It is used in mixer circuits of FM and TV receivers.
4. It is used in oscillator circuits.

### Difference between FET and BJT:

S.NO	JFET	BJT
1.	It is an unipolar device	It is a bipolar device
2.	Voltage controlled device	Current controlled device
3.	Less noise	More noise
4.	High switching speed	Low switching speed
5.	Not possible to thermal runaway	Possible to thermal runaway
6.	Simple fabrication	Difficult fabrication
7.	Source and drain terminals are interchangeable	Emitter and collector terminals are not interchangeable
8.	High input impedance	Low input impedance
9.	High power gain	Low power gain
10.	Generally the input terminal is reverse biased	Generally the input terminal is forward biased

### Specification of JFET:

In a JFET, the drain current  $I_D$  depends upon the drain voltage  $V_{DS}$  and the gate voltage  $V_{GS}$ . Any one of these variables may be fixed and the relation between the other two is determined.

#### 1. Mutual conductance or Transconductance (gm)

It is the ratio of a small change in the drain current to the corresponding changes in the gate voltage at a constant drain voltage.

$$g_m = \frac{\Delta I_D}{\Delta V_{GS}} / V_{DS} \text{ constant}$$

#### 2. Drain resistance (rd)

It is the ratio of a small change in the drain voltage to the corresponding changes in the drain current at a constant gate voltage.

$$r_d = \frac{\Delta V_{DS}}{\Delta I_D} / V_{GS} \text{ constant}$$

#### 3. Amplification factor ( $\mu$ )

It is the ratio of a small change in the drain voltage to the corresponding change in the gate voltage at a constant drain current.

$$\mu = \frac{\Delta V_{DS}}{\Delta V_{GS}} / I_D \text{ constant}$$

#### 4. Power dissipation (PD)

It is the product of  $I_D$  and  $V_{DS}$

$$PD = V_{DS} \cdot I_D$$

#### 5. Pinch-off voltage

It is the minimum drain to source voltage at which the drain current essentially becomes constant.

### FET AMPLIFIER:

The small signal models for the common source FET can be used for analyzing the three basic FET amplifier configurations. i.e.,

1. Common gate (CG) amplifier
2. Common drain (CD) amplifier
3. Common source (CS) amplifier

The CS amplifier which provides good voltage amplification is most frequently used. The CD amplifier with high input impedance and unity voltage gain is used as a buffer amplifier. The CG amplifier is used as high frequency amplifier.

#### Common Source (CS) amplifier:

A common source amplifier using JFET is shown in the fig. The resistors  $R_1$ ,  $R_2$  and  $R_S$  provide voltage divider bias, and set the operating point of the JFET. The capacitor  $C_S$  also bypasses the amplified AC signal. The coupling capacitors  $C_1$  and  $C_O$ , also used to block the DC signal.

When a small AC signal is applied to the gate terminal, it produces variations in gate-source voltage. This produces a sinusoidal drain current. Since an AC current flows through the drain resistor, we get an amplified AC voltage at the output.

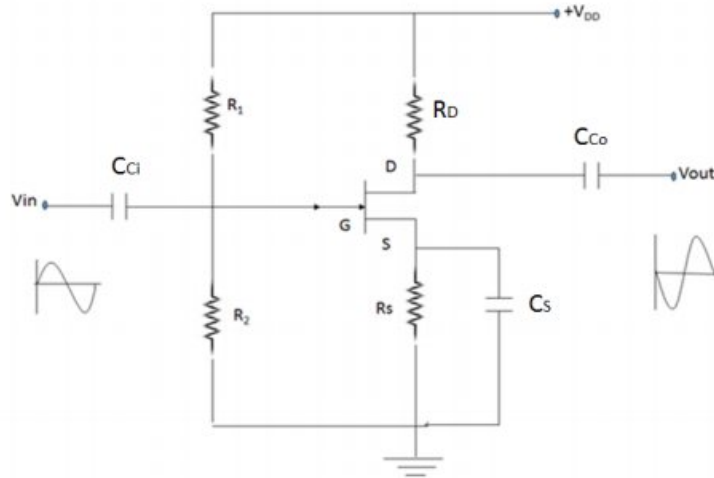

An increase in gate-source voltage produces more drain current, which means the drain voltage is decreasing. So the positive half cycle of the input signal produces negative half cycle of output voltage. Similarly the negative half cycle of the input signal produces positive half cycle of output voltages. Thus the output is  $180^\circ$  out of phase with the input signal.

### UNI JUNCTION TRANSISTOR (UJT):

UJT is a three terminal semi-conductor switching device. It has only one PN junction. The basic structure and symbol of UJT is shown in fig. It consists a lightly doped N-type silicon bar with a heavily doped P-type material is diffused into the bar, forms a PN junction. The ohmic contacts are provided at the ends emitter(E). Two ohmic contacts are provided at the ends of N-type silicon bar called base-1 ( $B_1$ ) and base-2 ( $B_2$ ). The resistance between B and B is called inter base resistance.

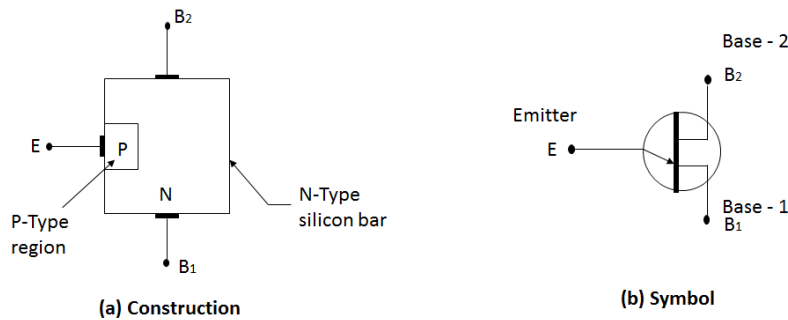

### Equivalent circuit of UJT:

The equivalent circuit of UJT is shown in the fig. The diode D represents the PN junction. According to the emitter terminal, interbase resistance ( $R$ ) is separated into two resistances,  $R_{B1}$  and  $R_{B2}$ . Hence  $R_{BB} = R_{B1} + R_{B2}$ . The resistance  $R_{B1}$  is variable, because its value can be varied, according to the bias voltage between P and N junction.

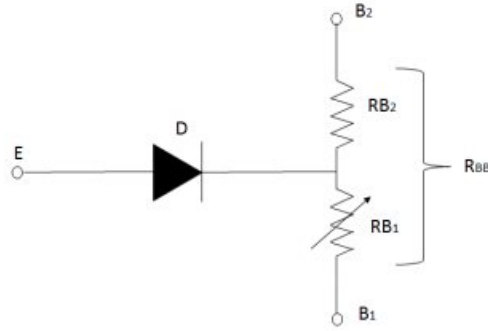

From the equivalent circuit,

The voltage across the resistor  $RB_1 = V_1 = \frac{R_{B1} T}{R_{B1} + R_{B2}} \times V_{BB}$

$$= \frac{R_{B1}}{R_{BB}} \times V_{BB}$$

$$V_1 = \eta V_{BB} \quad (\eta = R_{B1}/R_{BB})$$

Where,  $\eta$  is known as intrinsic standoff ratio. The value of  $\eta$  varies between 0.51 to 0.82.

**UJT OPERATION:**

The biasing arrangement of UJT is shown in the fig. The terminal  $B_2$  is always positive voltage ( $V_{BB}$ ) with respect to  $B_1$ . Usually a positive voltage ( $V_{EE}$ ) is applied to the terminal  $E$  with respect to  $B_1$ . The operating condition of UJT depends upon their emitter voltage ( $V_{EE}$ ).

According to the base voltage  $V_{BB}$ , voltage  $V_1$  is always developed across the resistor  $R_{B1}$  and, which is applied to the cathode terminal of the PN junction diode (in equivalent circuit). When the emitter voltage is zero, the diode works in reverse bias, so no emitter current flows. Now the UJT is in OFF state. Now a small leakage current only flows from  $B_2$  to  $E$ .

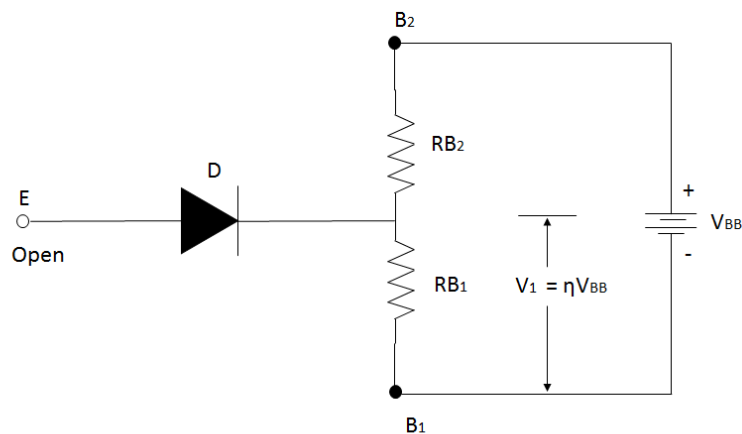

When a positive voltage is applied to the emitter, the PN junction is also in reverse biased. If the emitter voltage is linearly increased, which reduces the amount of reverse bias of the PN junction? When the applied voltage is increased greater than  $V_1$ , the PN junction will be forward biased. Now the holes are injected from P-region into N-region. The holes are repelled by the terminal  $B_2$  and are attracted by the

terminal  $B_1$ . Now the accumulation of holes in E to  $B_1$  region reduces the resistance in this section. Hence emitter current  $I_E$  is increased and the voltage  $V_E$  is decreased. Now the device is in the 'ON' state.

When a negative voltage is applied to the emitter (E), the PN junction is reverse biased, and the emitter current is very low. The device is now in 'OFF' state.

### Characteristics of UJT:

The circuit diagram for finding the emitter characteristics of UJT is shown in the fig. The curve plotted between emitter voltage ( $V_{EE}$ ) and the emitter current ( $I_E$ ) at a given  $V_{BB}$  is called emitter characteristics of UJT.

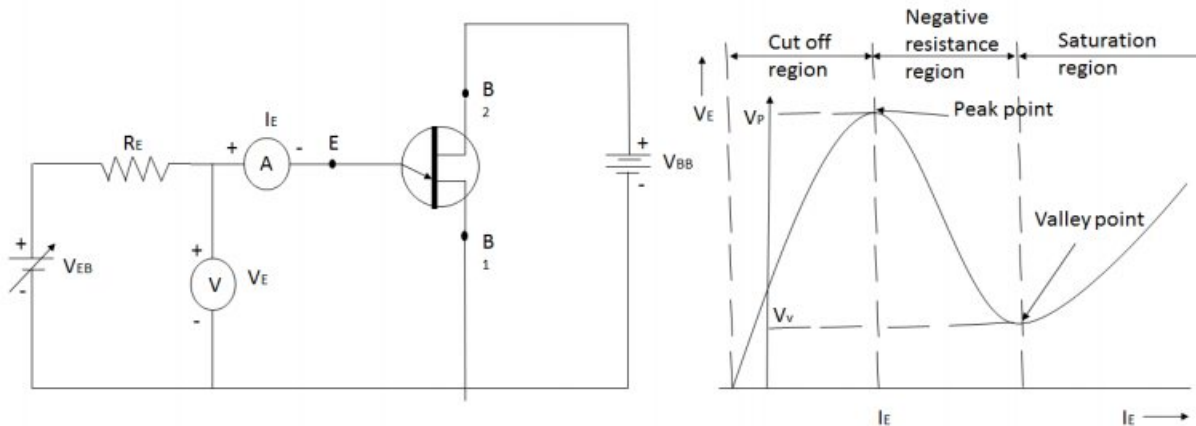

Here up to the peak point, the diode is reverse biased. Hence the region to the left of the peak point is called cut-off region. The UJT has a stable firing voltage (peak voltage) which depends on  $V_{BB}$ . After the firing voltage, the diode starts conduction. Now the current  $I_E$  is linearly increased and  $V_E$  is linearly decreased, which produce a negative resistance region. This region lies in between peak point and valley point. After the valley point, current becomes saturation. The region beyond the valley point is called saturation region. In this region the UJT is in 'ON' state.

### Applications:

1. It is used in timing circuits
2. It is used in phase control circuits
3. It is used in trigger SCR's and TRIAC's
4. It is used in pulse generator
5. It is used in saw tooth generator
6. It is used in switching circuits.

### UJT as a Relaxation Oscillator

Unijunction transistor can be used to generate saw tooth signal. In sawtooth signal, the voltage increases slowly and falls down to zero in short time. The circuit diagram and waveform of UJT relaxation oscillator is shown in fig.

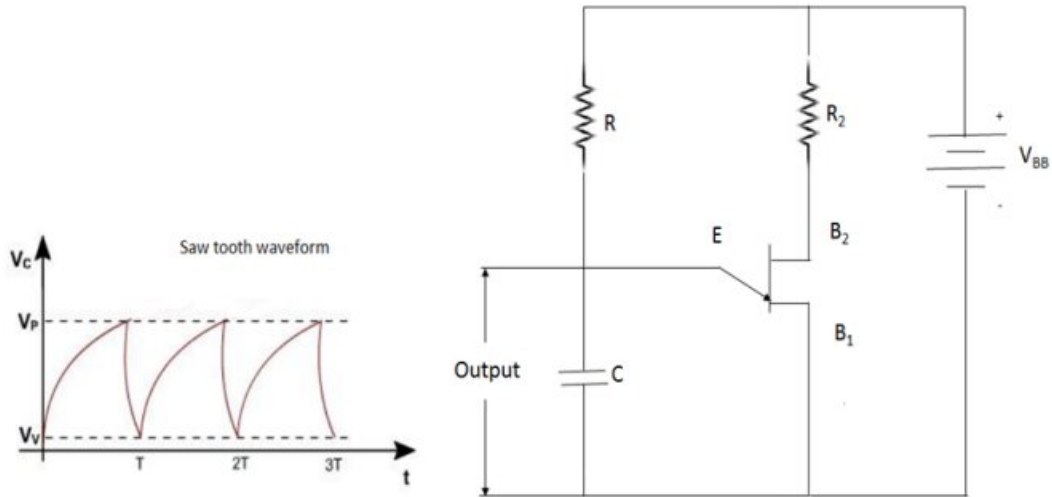

A capacitor  $C$  is connected in between the terminals  $E$  and  $B_1$ . This capacitor voltage is used to trigger the UJT, and also acts as the output signal of the relaxation oscillator. The charges of the capacitor depend upon the conduction level of UJT. Before conduction, the capacitor charges through  $R_1$ , and then after conduction the capacitor discharges through the emitter to base1 ( $B_1$ ) path of UJT.

When the supply voltage is given, the capacitor charges through  $R_1$ . As long as the capacitor voltage is less than the base1 to emitter voltage  $V_{EB1}$ , the junction is reverse biased and the UJT will not conduct. When the capacitor (output) voltage exceeds the reverse biased voltage ( $V_{EB1}$ ), the UJT starts conducting.

During conduction, the resistance between emitter and base 1 falls to a lower value. Hence the capacitor discharges the voltage in a low time, and the UJT again goes to non-conduction level. The capacitor repeats the charge and discharges functions continuously. By this cumulative action, a continuous saw tooth signal is produced at its output.

**Applications:**

1. Used in Television
2. Used in Radar equipment
3. Used in Oscilloscope

## UNIT - IV SCR, DIAC, TRIAC & MOSFET

### SILICON CONTROLLED RECTIFIER (SCR):

#### Construction:

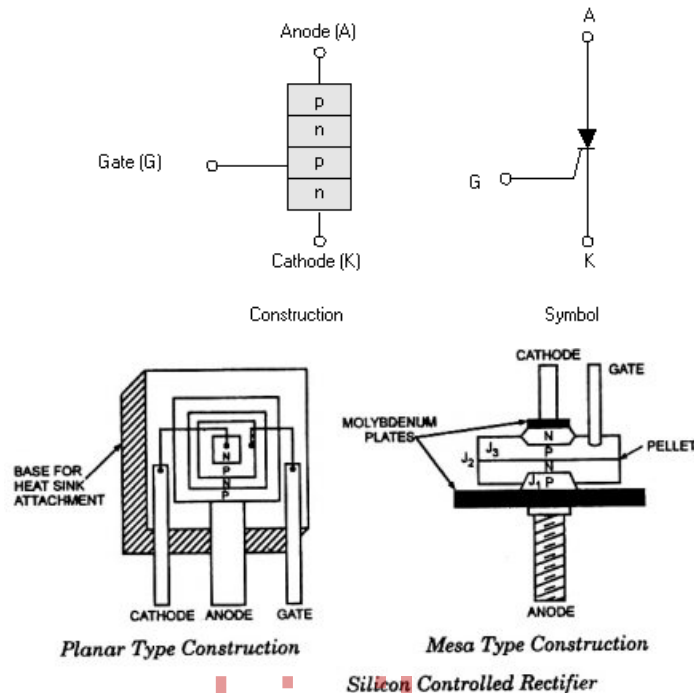

It is a four layer P-N-P-N device. It has 3 junctions. For low power SCRs, planar construction is used. This construction is used for making a number of units from a single silicon wafer. Here all the junctions are diffused.

For high power SCRs Mesa construction is used. Here the inner junction is obtained by diffusion and the other two layers are alloyed to it. To handle large currents, it is braced with tungsten or molybdenum plates to provide mechanical strength. From these plates, heat sinks are attached.

#### Operation:

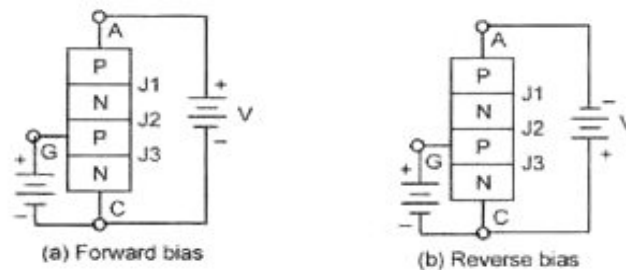

#### When gate is at zero potential:

The anode is made +ve w.r.t cathode. Junctions J1&J3 are forward biased and junction J2 is reverse biased. The SCR is in forward blocking state or off state. When the voltage is increased, junction J2 breakdown. This is the avalanche breakdown. There will be free carrier movement across all the three junctions. So, the anode current increases. The voltage drop across the device will be the ohmic drop in

the four layers. The device is now in the conducting state (or) ON state. The voltage at which junctions J2 breaks down is called forward break over voltage  $V_{BO}$ .

When the anode is made -ve w.r.t cathode, j1&j3 are reverse biased and j2 is forward biased. A small reverse leakage current will flow. This is the reverse blocking state. When the voltage is increased, at some voltage junctions j1&j3 will break down. This voltage is called reverse break down voltage  $V_{BR}$ . Heavy current flow through the device.

**When gate is at positive potential:**

When gate is given +ve potential, the reverse leakage current through junction j2 is increased. Because the gate current consist mainly of  $e^{-n}$  flow from the cathode to gate. These  $e^{-ns}$  reach region nearer to j2 and add to the minority carrier concentration in the layer. This leads to the breakdown even though the applied forward voltage is lower than  $V_{BO}$ . Thus the gate provides a very convenient method for switching the device from OFF to ON, with low anode-to- cathode voltages. Once the device becomes on, the anode current is limited only by the external impedance. The gate losses its control.

**Characteristics:**

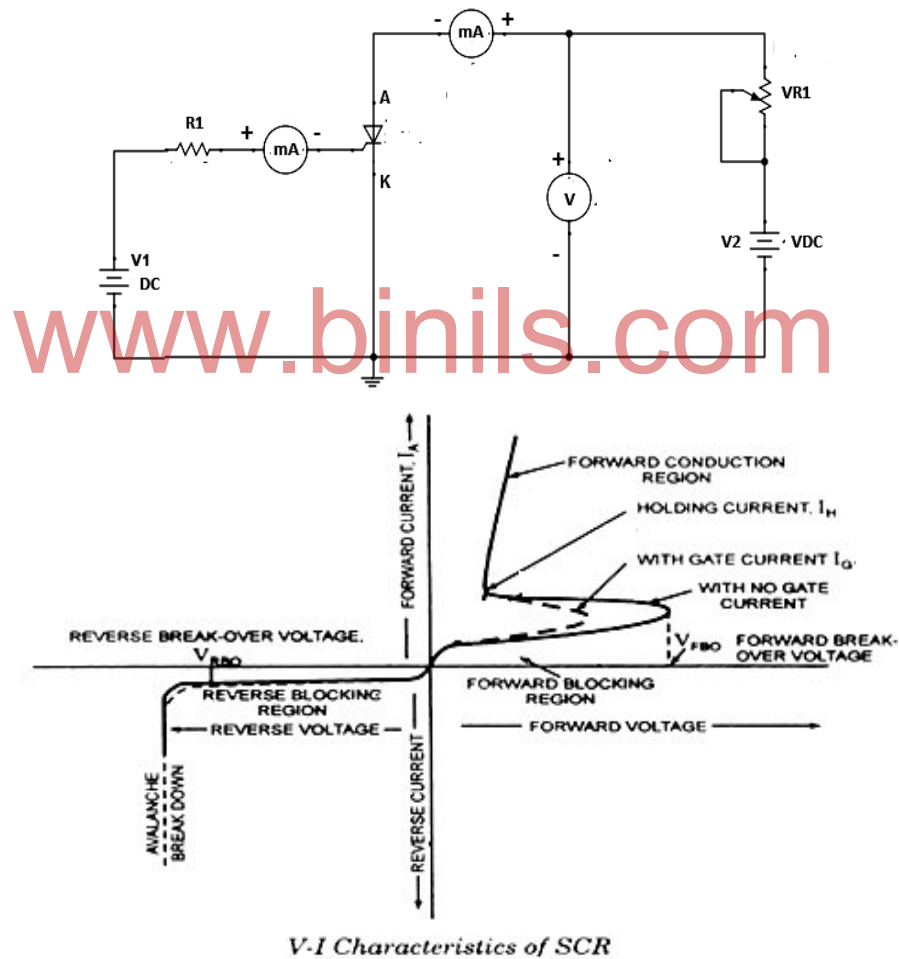

**Region OA:** forward blocking state. Small leakage current flows

**AB:** conduction region

**OC:** reverse blocking state.



**CD:** break down region

$I_h$ : Holding current: when the anode current falls below this current, the devices goes to off state.

$I_L$ : latching current: the forward current required to switch on the SCR from off state.

**Comparison between SCR and BJT:**

S.No	SCR	BJT
1	4 Layer device	3 layer device
2	High voltage and high current device	Low voltage and high current device
3	Less temperature sensitive	More temperature sensitive
4	Used as a controlled rectifier	Used as an amplifier

**SCR AS A SWITCH:**

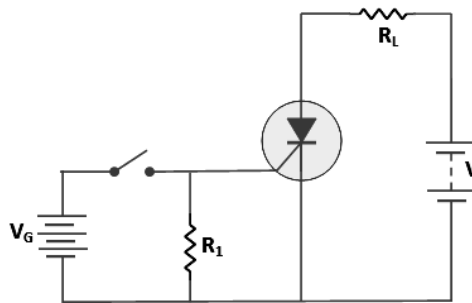

The SCR has only two states namely ON state and OFF state. When proper gate current is passed, the SCR starts conducting heavily and becomes ON. This corresponds to the ON condition. When the anode current is reduced below the holding current, the SCR is turned OFF. This is the OFF state. These operations are very similar to that of mechanical switch.

**Advantages:**

1. It gives noiseless operation.
2. Switching speed is high (up to  $10^9$  operations per second).
3. Small size.

**SCR AS HALF WAVE CONTROLLED RECTIFIER:**

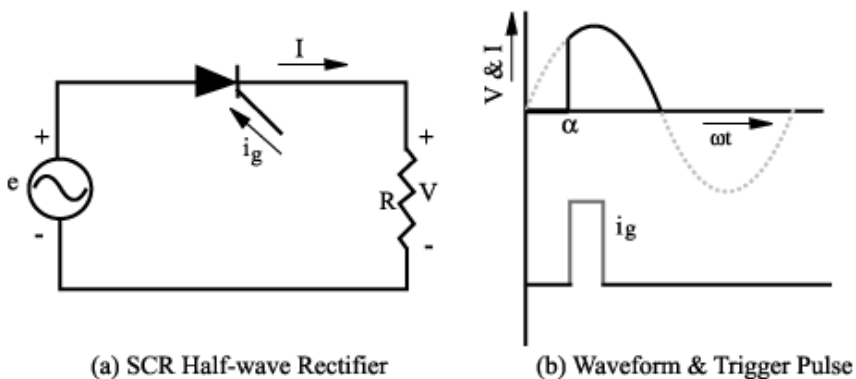

During the positive half cycle of i/p AC voltage, the SCR will conduct by giving proper gate current. When SCR becomes ON it conducts throughout the positive half cycle. When the AC voltage

becomes 0, it stops conducting. During the negative half cycle of the AC, SCR does not conduct. The SCR also block the part of the positive I/p up to a point where SCR is triggered ON. So by proper gate current, the SCR can be made to conduct full or part of positive half cycle. Thus the power fed to the load is controlled.

**SCR AS FULL WAVE CONTROLLED RECTIFIER:**

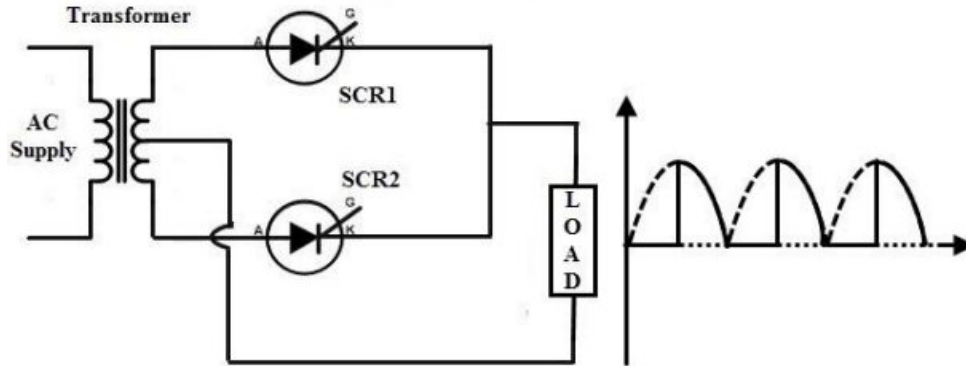

During the positive half cycle of the i/p, anode of SCR1 is positive and that of SCR2 is negative. When the i/p reaches  $V_1$ , SCR1 becomes on. During this period SCR2 is in OFF condition. During the negative half cycle of the i/p, anode of SCR2 is positive and that of SCR1 is negative. When the i/p reaches  $V_1$ , SCR2 becomes on. During this period SCR1 is in OFF condition. Thus by changing the gate current, the conduction can be changed.

**Firing angle:** The angle at which the SCR starts conducting during the positive half cycle is called firing angle.

**Conduction angle:** The angle through which the SCR is conducting is called conduction angle.

$$\text{Conduction angle} = (180 - \text{Firing angle}).$$

**TRIAC:**

**Construction:**

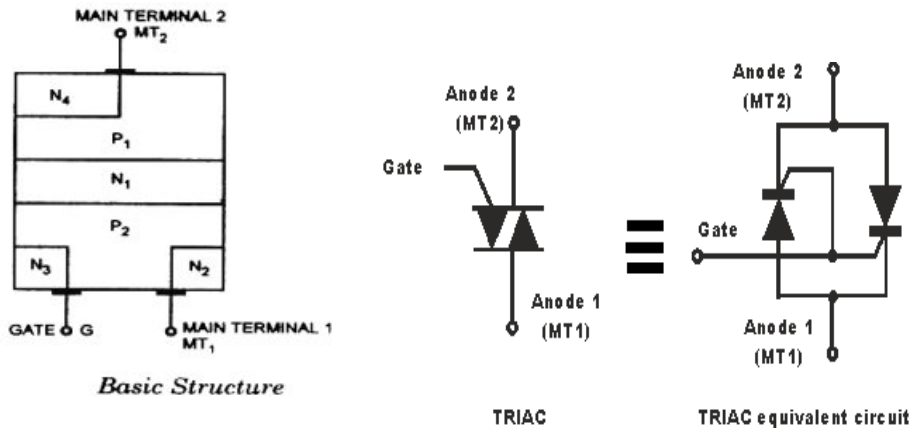

It is a six layer device. It is a bidirectional device. It conducts in both the directions. It has three terminals namely MT1, MT2 and gate. The gate contact is taken nearer to MT1. The ohmic contact of MT1 is made common to both N2&P2. The ohmic contact of MT2 is made common to both P1&N4. The

ohmic contact of gate is made common to both P2&N3. It is similar to two SCR's connected in anti-parallel.

**OPERATION:**

The TRIAC can be turned on by applying either a +ve & -ve voltage to the gate.

**MT2 is +ve w.r.t MT1:**

Now the SCR P1-N1-P2-N2 is selected. P1-N1 & P2-N2 junctions are forward biased and P2-N1 junction is reversed biased.

**Mode 1: gate +ve:**

When gate is given +ve potential, the TRIAC acts as SCR with cathode gate. The junction P2-N1 breakdown and the device becomes ON. This is the recommended mode of operation.

**Mode 2: gate -ve:**

This operation is called junction gate operation. Here P1-N1-P2-N3 acts as mini SCR and it turns on. So, the left hand portion conducts. Due to potential gradient, this current will flow to right. The main SCR P1-N1-P2-N2 turns on. So, P2-N1 junction breaks down and the device becomes on.

**MT1 is +ve w.r.t MT2:**

Now the SCR P2-N1-P1-N4 is selected. P2-N1 and P1-N4 junctions are forward biased. P1-N1 junction is reverse biased.

**Mode 3: gate +ve**

This operation is called remote gate operation. Now P2-N2 junction becomes forward biased. This increases the charge carriers in N1. So, P1-N1 junction breakdown and the device becomes on.

**Mode4: gate -ve:**

Now P2-N3 junction becomes forward biased. This increases the charge carriers N1. So, P1-N1 junction breakdown and the device becomes on.

**Characteristics:**

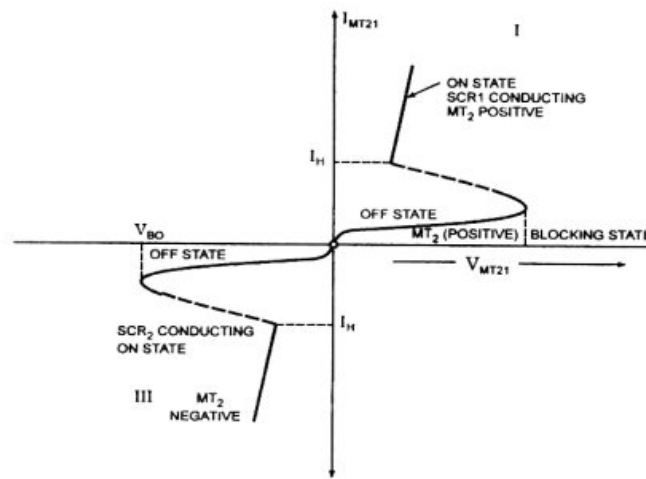

V-I Characteristic of a Triac

1. The characteristics in I & III quadrant are similar to that of SCR characteristics.
2. The device can be turned on by giving either +ve (or) -ve voltage to gate.
3. The break over voltage is defined by the gate current. When gate current is high, the device goes to ON state at low voltage.

## DIAC:

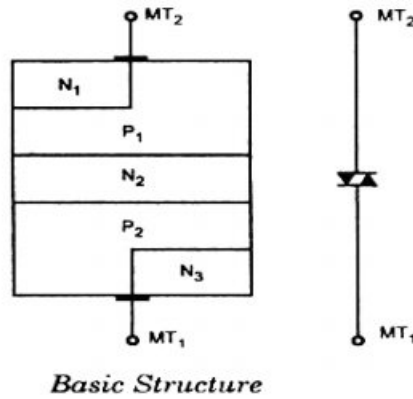

### Construction:

It is a five layer device. It is a bidirectional device. It conducts in both the directions. It has two terminals namely MT1&MT2. The ohmic contact of MT1 is made common to both P1&N1. The ohmic contact of MT2 is made common to both P2&N3. It has no gate.

### Operation:

It is similar to two SCR's connected in anti-parallel without gate. When MT1 is given +ve w.r.t MT2, the SCR P2-N2-P1-N1 is selected. When the applied voltage is increased to the break over voltage, the junction P1-N2 breaks down and the device goes to ON state. When MT2 is given +ve w.r.t MT1, the SCR P1-N2-P2-N3 is selected. When the applied voltage reaches the break over voltage of this SCR, the junction P2-N2 breakdown and the device goes to ON state. The characteristics are similar in both directions. It resembles the SCR characteristics.

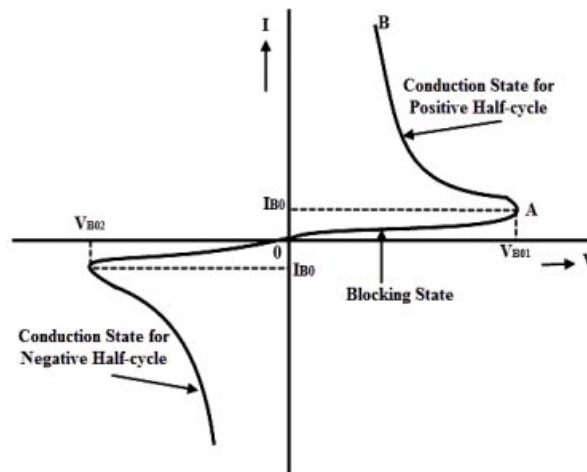

**\DIAC AS A BIDIRECTIONAL SWITCH:**

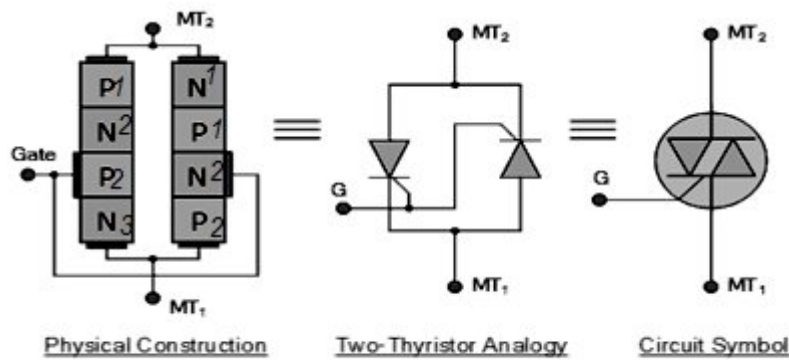

By giving proper voltage to MT1 and MT2, DIAC can pass current in either direction. When MT1 is positive w.r.t. MT2, layers are selected. When the i/p reaches break over voltage, the DIAC conducts current from MT1 to MT2. When MT2 is positive w.r.t. MT1, layers are selected. When the i/p reaches break over voltage, the DIAC conducts current from MT2 to MT1. If the applied voltage on either direction is less than its break over voltage, the DIAC is in OFF condition. Thus the DIAC behaves as a switch in both the directions.

**MOSFET (OR) IGFET:**

**(Metal Oxide Semiconductor Field Effect Transistor or Insulated Gate Field Effect Transistor)**

MOSFETs are of two types namely Depletion type MOSFET (D-MOSFET) and Enhancement type MOSFET (E-MOSFET).

**Depletion type MOSFET (N CHANNEL):**

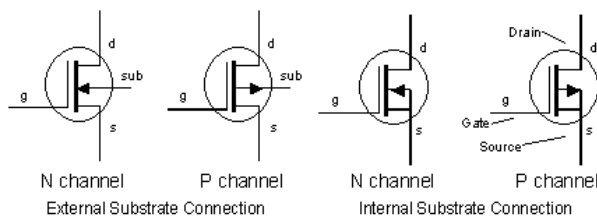
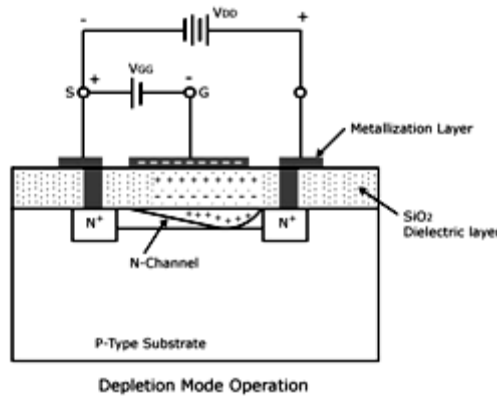

### Construction:

In a p-type substrate, two highly doped  $n^+$  regions are diffused. These  $n^+$  regions act as source and drain. Between these two regions a 'n' region is formed which acts as the channel. Over the substrate a thin layer of silicon di-oxide ( $\text{SiO}_2$ ) is formed. Ohmic contacts are made in the drain & source. Over the channel, an aluminium layer is formed. Gate contact is taken from the aluminium layer. Since gate is insulated from the channel by  $\text{SiO}_2$ , it is called IGFET. The aluminium layer, channel and the insulator  $\text{SiO}_2$  acts as capacitor.

### Operation:

The D-MOSFET can be operated in two modes namely depletion mode and enhancement mode.

#### Depletion mode:

When gate is at zero potential and when  $V_{DS}$  is increased, the drain current flows through the channel. When gate is given  $-ve$  potential, because of the capacitance effect,  $+ve$  charges are induced in the channel. As a result of this the channel is depleted of free  $e^{-ns}$ . Thus the conduction is reduced. As the value of  $-ve$  gate voltage is increased, the value of drain current  $I_D$  decreases. The operation is similar to that of JFET.

#### Enhancement mode:

Here gate is at  $+ve$  potential. Because of the capacitance effect, free  $e^{-ns}$  are induced in the channel. The greater the gate voltage, the greater is the number of free  $e^{-ns}$ . This enhances i.e. increases the conduction and  $I_D$  increases.

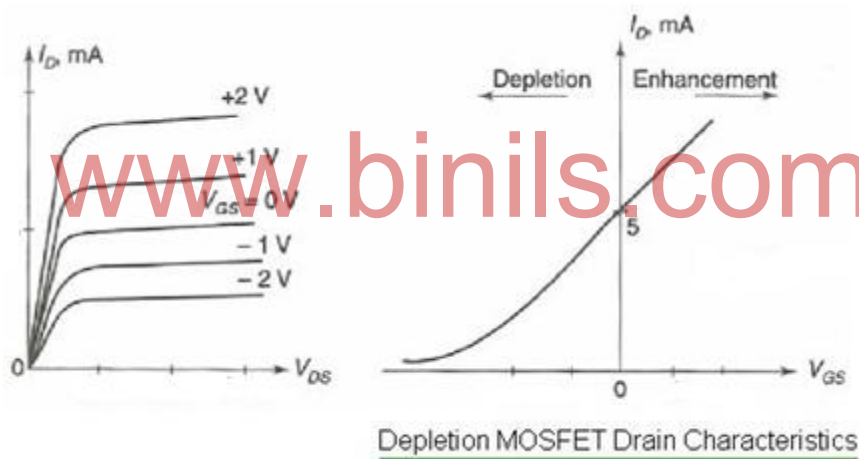

### Enhancement-type MOSFET (n- channel):

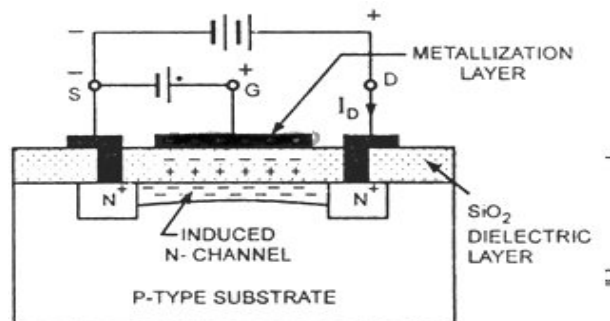

Operation of N-Channel E-MOSFET

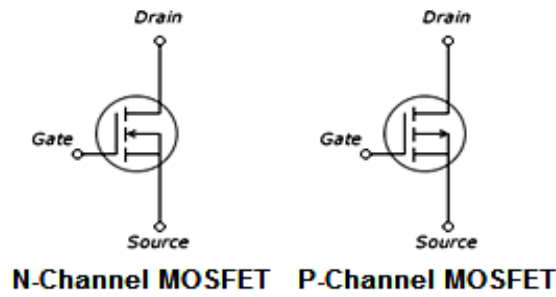

**Construction:**

In a p-type substrate, two highly doped  $n^+$  regions are diffused. These  $n^+$  regions acts as source and drain. Over the substrate a thin layer of  $SiO_2$  is formed. Ohmic contacts are made in the drain and source. Over the channel an aluminum layer is formed. Gate contact is taken from the AL layer. There is no channel between the drain and source. Since the gate is insulated from the channel by  $SiO_2$ , it is called IGFET. The combination of aluminium layer, substrate and  $SiO_2$  acts as capacitor.

**Operation:**

This MOSFET is always operated with the +ve gate to source voltage. When  $V_{GS}=0$ , there is no drain current because of the absence of the channel. When  $V_{GS}$  is given +ve voltage, because of the capacitance effect, free electrons are induced in the substrate. It forms the channel between the source and drain. This layer is also called as inversion layer. When  $V_{DS}$  is given a +ve voltage, the drain current  $I_D$  flows in the device. The Gate – Source voltage at which the channel is induced and the MOSFET begins to conduct is called threshold voltage.

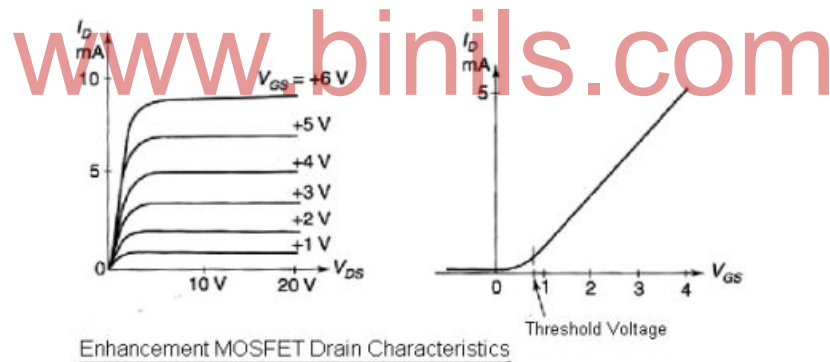

**Depletion type MOSFET (P CHANNEL):**

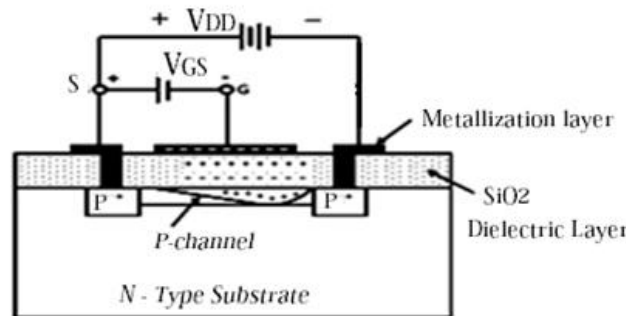

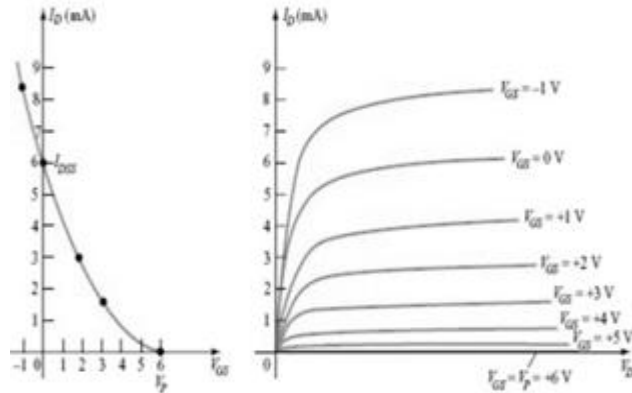
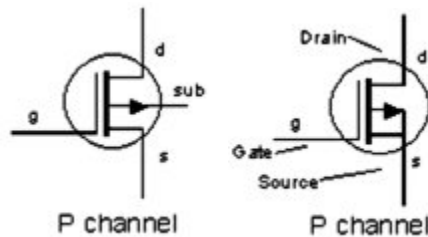

### Construction:

In a n-type substrate, two highly doped  $p^+$  regions are diffused. These  $p^+$  regions act as source and drain. Between these two regions a 'p' region is formed which acts as the channel. Over the substrate a thin layer of silicon di-oxide ( $\text{SiO}_2$ ) is formed. Ohmic contact is made in the drain & source. Over the channel, an aluminium layer is formed. Gate contact is taken from the aluminium layer. Since gate is insulated from the channel by  $\text{SiO}_2$ , it is called IGFET. The aluminium layer, channel and the insulator  $\text{SiO}_2$  acts as capacitor.

### Operation:

The D-MOSFET can be operated in two modes namely depletion mode and enhancement mode. When gate is at zero potential and when  $V_{DS}$  is increased, the drain current flows through the channel.

### Depletion mode:

When gate is given +ve potential, because of the capacitance effect -ve charges are induced in the channel. As a result of this the channel is depleted of holes. Thus the conduction is reduced. As the value of +ve gate voltage is increased the value of drain current  $I_D$  decreases. The operation is similar to that of JFET.

### Enhancement mode:

Here gate is given a -ve potential. Because of the capacitance effect, holes are induced in the channel. The greater the gate voltage, the greater is the number of holes. This enhances i.e. increases the conduction and  $I_D$  increases.



**Enhancement-type MOSFET (p- channel):**

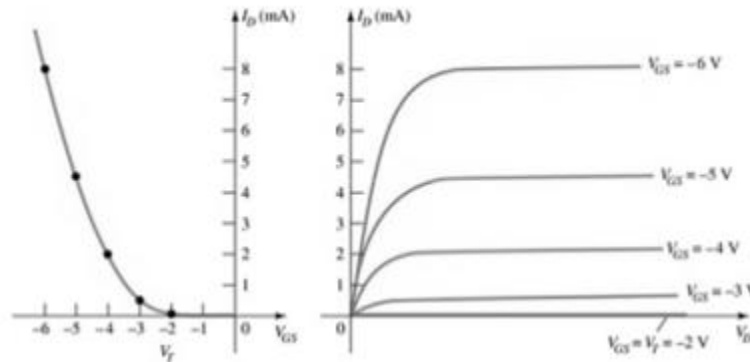
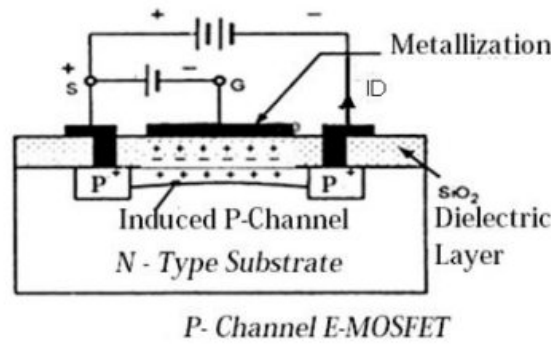

[www.binils.com](http://www.binils.com)

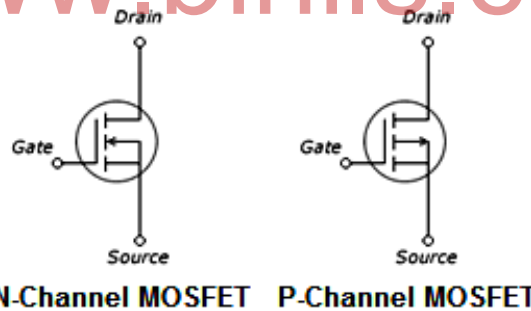

**Construction:**

In a n-type substrate, two highly doped  $p^+$  regions are diffused. These  $p^+$  regions acts as source and drain. Over the substrate a thin layer of  $SiO_2$  is formed. Ohmic contacts are made in the drain and source. Over the channel an aluminum layer is formed. Gate contact is taken from the aluminium layer. There is no channel between the drain and source. Since the gate is insulated from the channel by  $SiO_2$ , it is called IGFET. The combination of Al layer, substrate and  $SiO_2$  acts as capacitor.

**Operation:**

This MOSFET is always operated with the - ve gate to source voltage. When  $V_{GS}=0$ , there is no drain current because of the absence of the channel. When  $V_{GS}$  is given - Ve voltage, because of the capacitance effect, holes are induced in the substrate. This forms the channel (induced channel). This channel forms between the source and drain. This layer is also called as inversion layer. When  $V_{DS}$  is given

a - Ve voltage, the drain current  $I_D$  flows in the device. The Gate – Source voltage at which the channel is induced and the MOSFET begins to conduct is called threshold voltage.

**Difference between JFET & MOSFET:**

S.No	JFET	MOSFET
1	Can be operate in depletion mode	Can be operated in two modes in depletion mode and enhancement mode
2	Gate current is high	Gate current is low
3	Fabrication is difficult	Fabrication is easier
4	Input impedance is less	Input impedance is very high.

**MOSFET AS A SWITCH:**

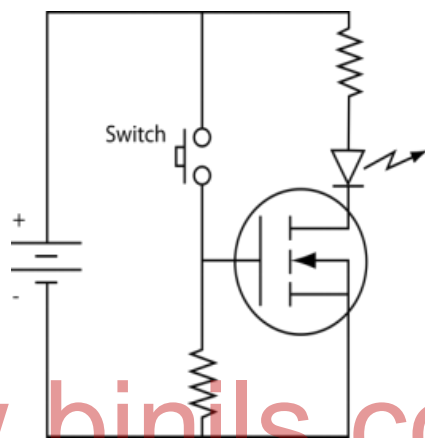

[www.binils.com](http://www.binils.com)

MOSFET can be used as an electronic switch. When the Gate voltage is less than threshold voltage, there will be no channel. So the drain current is zero. The o/p voltage is high. This is equivalent of open switch. When the Gate voltage is more than that of Threshold voltage, channel is induced. Drain current passes through the device. The o/p voltage is 0. The device becomes ON. This is equivalent to closing switch.

**Applications of SCR:**

1. Power switching circuits (for both AC and DC)
2. Over voltage protection circuits
3. Controlled Rectifiers
4. Inverters
5. AC Power Control (including lights, motors, etc.)
6. Battery Charging Regulator
7. Remote Switching Units
8. Phase Angle Triggered Controllers
9. Timing Circuits
10. IC Triggering Circuits
11. Welding Machine Control
12. Temperature Control Systems

**Applications of TRIAC:**

1. For phase control
2. For motor speed control
3. In lamp dimmer circuits
4. In heat control circuits
5. As static switch
6. In electronic change over in transformer taps

**Applications of DIAC:**

1. For triggering of TRIAC
2. In relaxation oscillator
3. In heat control
4. In lamp dimmer circuit
5. In speed control of universal motor

**Applications of MOSFET:**

1. Switch
2. Amplifiers
3. Choppers
4. SMPS
5. Linear voltage regulators
6. Inverters

[www.binils.com](http://www.binils.com)

**UNIT - V**  
**OPTO ELECTRONICS DEVICES AND WAVE SHAPING CIRCUITS**

**PHOTO CONDUCTIVE CELL (OR) LIGHT DEPENDENT RESISTOR:**

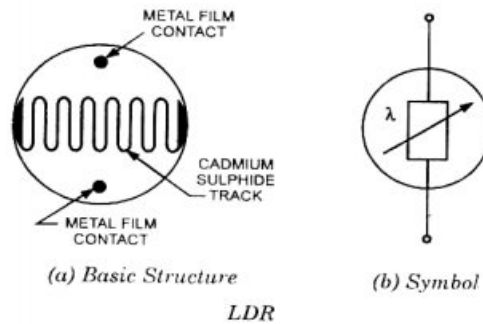

**Construction:**

It is generally made up of cadmium compounds such as cadmium sulphide (cds), cadmium selenide (cdse). The device is in the form of either a slab of a semiconductor in bulk form (or) a thin film deposited on an insulating substrate. The ohmic contacts are made at the opposite ends. The material is arranged in the form of a long strip, zigzagged across a disc. A glass (or) plastic cover may be included for protection.

**Operation:**

When the device is exposed to light, the conductivity increases. The radiation supplied to the semiconductor ionizes the covalent bonds. Hence new  $e^{-h\nu}$ -hole pairs are produced. Due to this the resistance decreases and the conductivity is increased. Hence it is called photo resistor (or) photo conductor.

**Characteristics:**

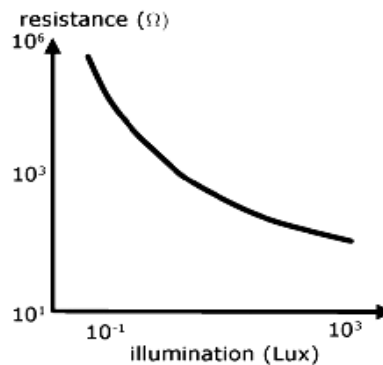

With the increase in illumination, the resistance decreases.

**Applications:**

LDRs are used

1. As switches
2. In counting application
3. In burglar alarms
4. In relay controls
5. As smoke detector
6. To measure intensity of light.

## LIGHT EMITTING DIODE (LED):

A p-n junction which emits light when forward biased is known as LED. The amount of light output is proportional to the forward current.

### Construction:

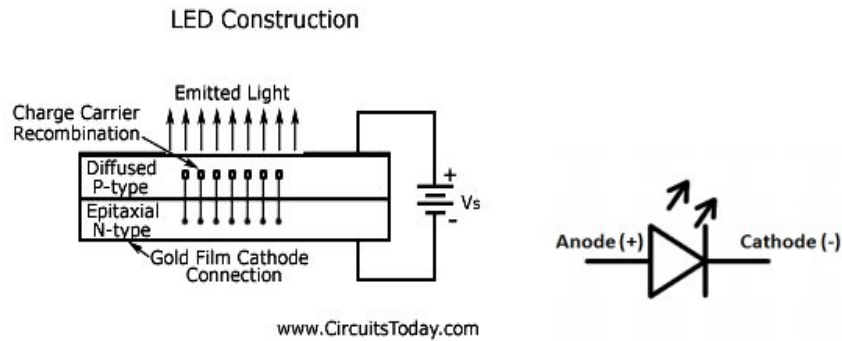

An n-type epitaxial layer is grown upon a substrate. The p- region is created by diffusion. The recombination occurs in the p- region. So this region is kept uppermost. The metal film anode is made such that most of the light is emitted from the p-region. A gold film is applied to the bottom of the device. It provides cathode connection. The colours of light depend on the LED materials.

Ga As – infrared (invisible)

Ga P – red or green

Ga As P – red or yellow

### Operation:

When the LED is forward biased, the  $e^{-ns}$  and holes move towards the junction. Then the charge carrier recombination takes place. So, it releases energy in the form of light. The brightness of the emitted light is directly proportional to the forward bias current. The characteristics are similar to that of a p-n junction diode.

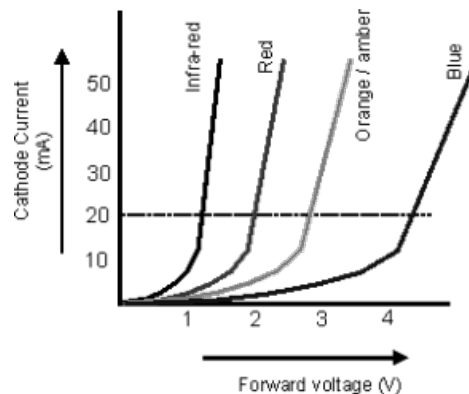

### Application:

LEDs are used

1. In numeric displays
2. In multimeters
3. In digital displays
4. In calculator
5. In panels
6. In digital watches

- 7. In video displays
- 8. In optical communication systems.

**7 SEGMENT LED:**

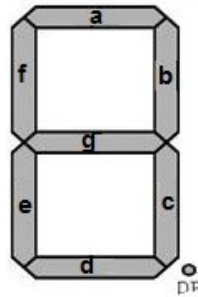

A display consisting of seven LEDs arranged in seven segments is called 7 segment displays. They are named from a to g. Each LED is called a segment. An additional LED is used for the indication of a decimal point. If a particular Led is forward biased, that LED will produce a light. By forward biasing various combinations, we can display the digits from 0 to 9 and some alphabets.

There are two types.

**Common Anode type:**

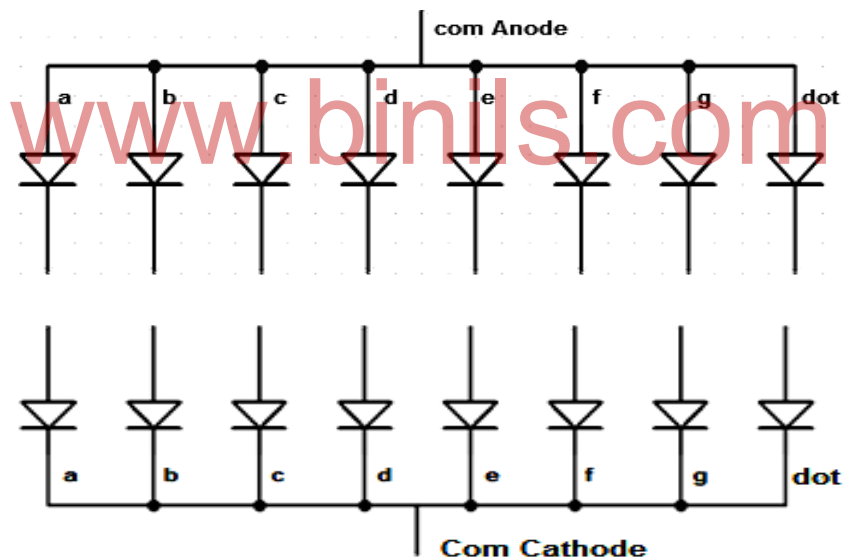

Here all the anodes are connected together. The common point is connected to +Vcc. A current limiting resistor is connected between each LED and ground.

**Common Cathode type:**

Here all the cathodes are connected together. The common point is connected to the ground. A current limiting resistor is connected between each LED and the supply.

## LIQUID CRYSTAL DISPLAY (LCD):

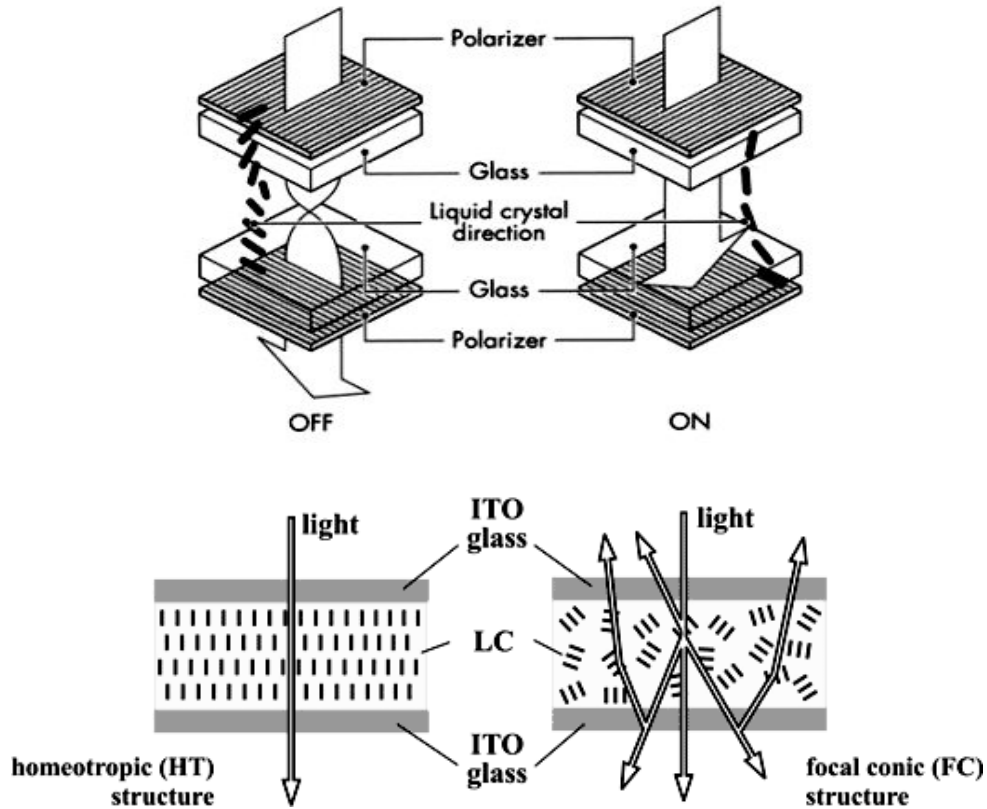

Liquid crystal is an organic compound containing carbon, hydrogen, oxygen and nitrogen. It will not emit light, it will alter the illumination.

### Construction:

A liquid crystal cell consists of a layer of liquid crystal sandwiched between glass sheets. The transparent metal film electrodes are deposited inside the glass sheets. When both glass sheets are transparent, it is known as transmissive type. When one plate is transparent and the other has reflective coating, it is called reflective type.

### Dynamic scattering mode:

When it is not activated, light is reflected from the mirror surface. The cell does not appear bright. When activated, the dynamic scattering phenomenon occurs and the cell appears bright.

### Field effect mode:

Here two thin polarizing optical filters are placed at the inside of each glass sheet. The L.C twists the light when the cell is not energized. This allows light to pass through the optical filters and the cell appears bright. When the cell is energized, no twisting of light takes place and the cell appears dark.

### Advantages:

1. Low power is required
2. Good contrast
3. Low cost.

**Disadvantages:**

1. Slow device
2. When DC is used life reduces
3. Occupy large area

**Applications:**

LCDs are used in

1. Displays
2. Image sensing circuits
3. Solid state video display
4. Digital watch.
- 5.

**Comparison between LED & LCD:**

S NO	LED	LCD
1	Consumes more power	Consumes less power
2	Good brightness level	Moderate brightness level
3	Life time is more	Life time is low
4	Emits the light	Will not emit the light
5	Its colors depend upon material used	It is monochrome in nature.

**OPTO COUPLER:**

It is the combined package of photo-emitting device and photo sensing device. It is used to electrically isolate one circuit from the other. It uses light to couple a signal from its i/p to its o/p.

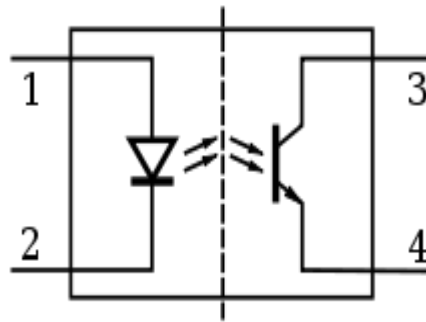

When LED is forward biased, it emits light. The light is sensed by the photo diode. The current flowing through the photodiode is directly proportional to the light. The optocoupler transfers signal without any coupling components.

**Applications:**

- Used to couple digital and analog signals.
- Used for interfacing high and low voltage system.
- Used for interfacing different types of logic circuits.



## PHOTO TRANSISTOR:



### Working:

There is no base connection in photo transistor. The light falls on the base collector junction. When there is no illumination, minority carriers are generated by room temperature. The collector current is given by

$$I_C = (1 + \beta) I_{C0}$$

When the light is turned on, additional minority carriers are photo generated. Now the total current is

$$I_C = (1 + \beta) (I_{C0} + I_L)$$

Where  $I_L$  is the reverse current due to light. The dark current in a photo transistor is larger than that of in photo diode.

### Characteristics:

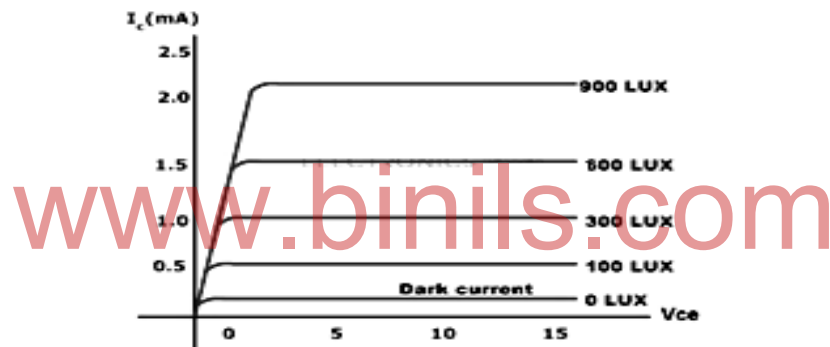

It is similar to that of CE output characteristics. When the light intensity increases, the collector current increases.

### Application:

1. In light operated relays
2. In electro optical shaft encoder.
3. In optical paper tape reader
4. In light detection system
5. As light operated switch
6. In brushless DC motor.

## DIODE CLIPPERS

**Definition:** It is a circuit which transmits that part of an arbitrary wave which lies above or below some reference level.

### Positive Diode Clipping Circuits

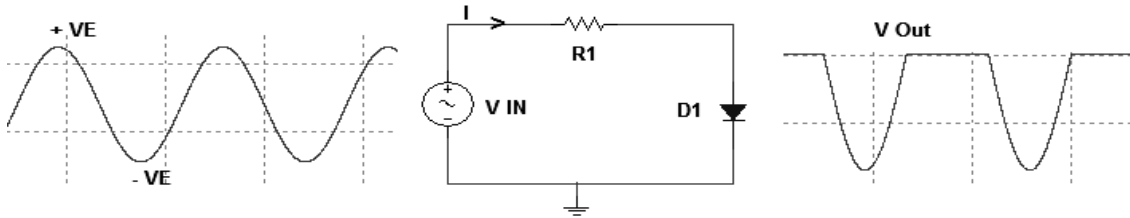

### Negative Diode Clipping Circuits

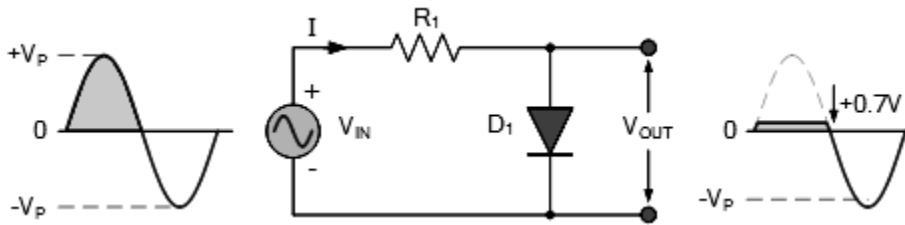

### Positive Bias Diode Clipping

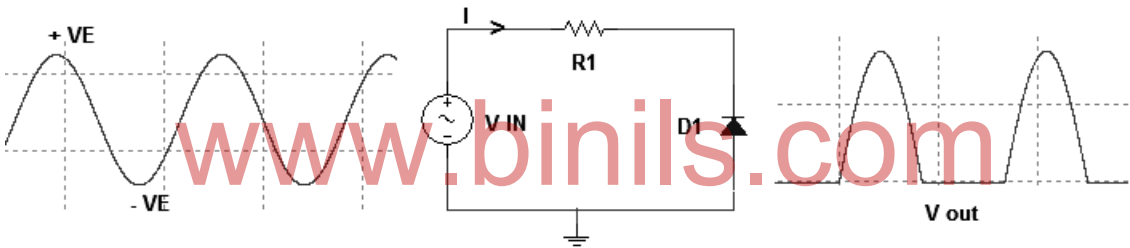

### Negative Bias Diode Clipping

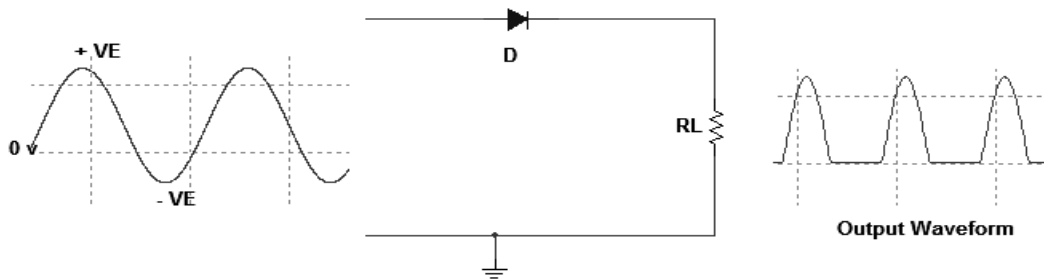
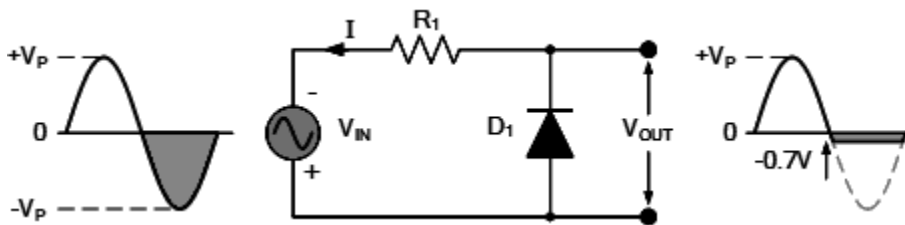

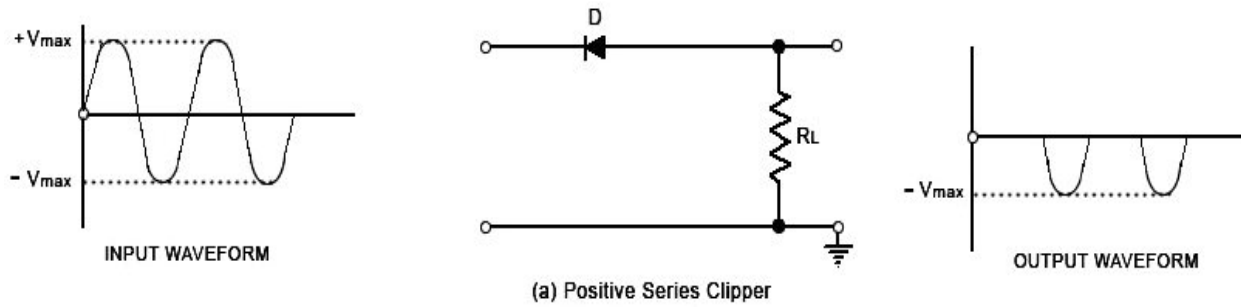

**Positive bias clipper**

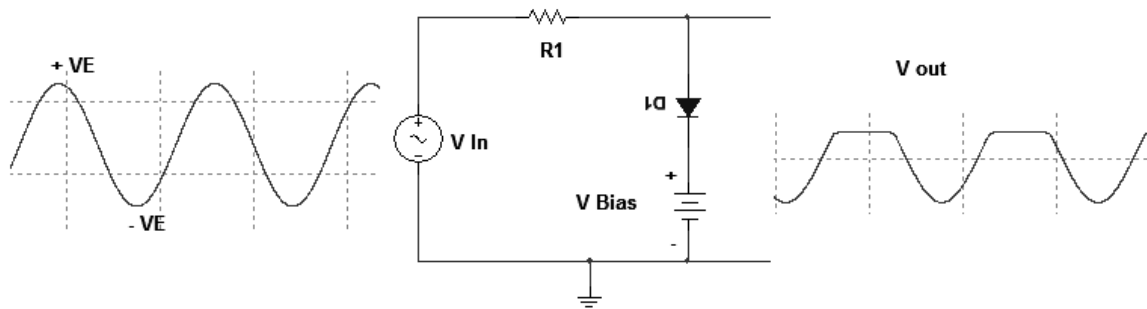

**Negative bias clipper**

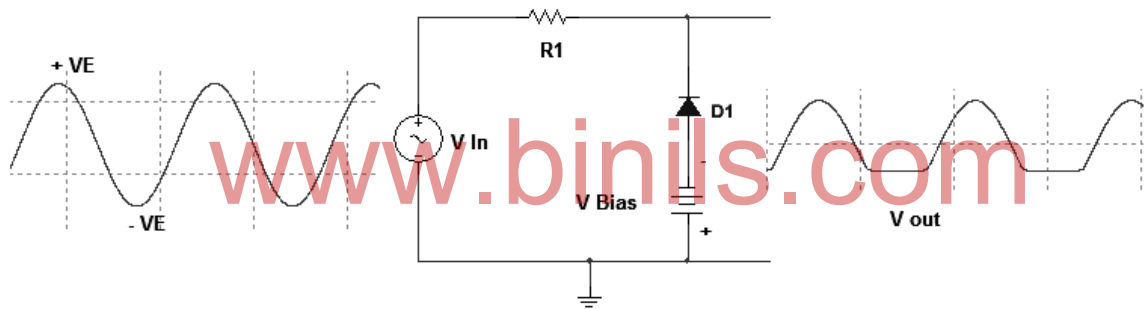

**CLAMPERS:**

**Definition:** It is a circuit which holds either amplitude extreme of a wave form to a given reference level is called clamper circuit.

**Negative clamper**

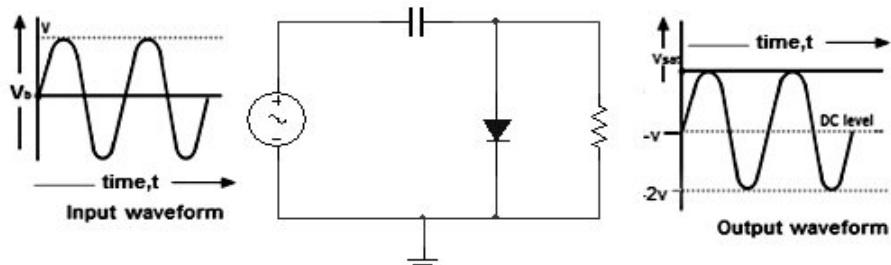

## Positive clamper

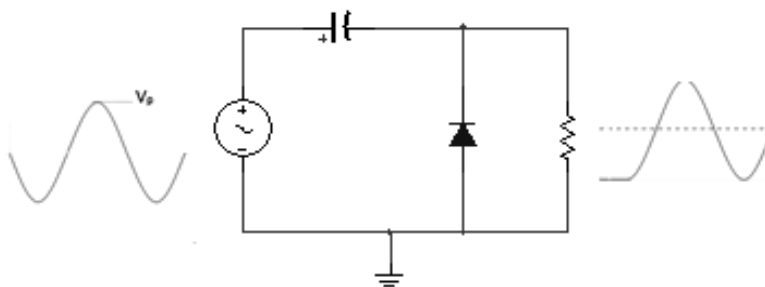

## SOLAR CELL:

This works on the principle of photo voltaic effect. It converts light energy into electrical energy.

### Construction:

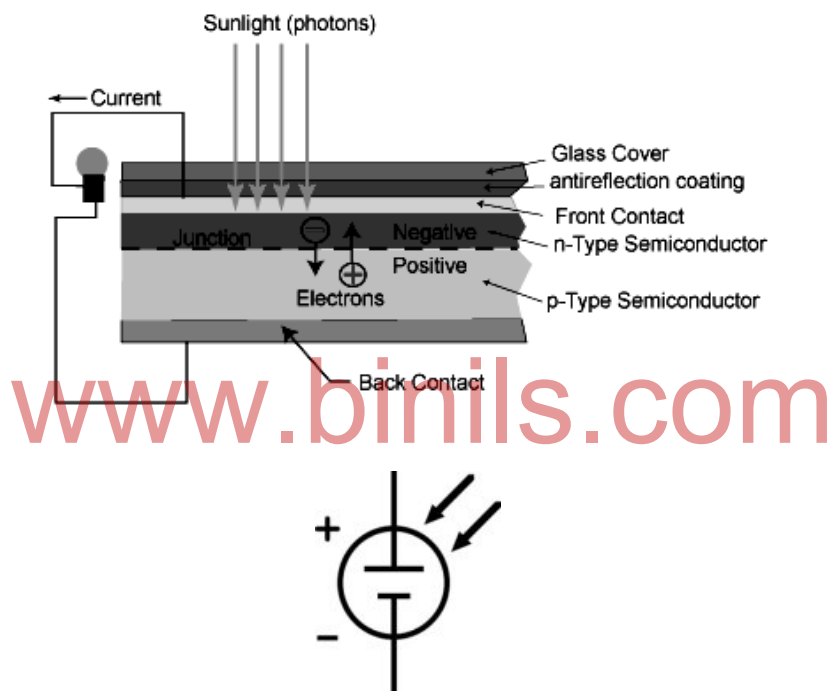

It consists of p-type and n-type silicon semiconductors. It is covered with a continuous conductive contact to which a wire lead is attached. The upper surface has a maximum area exposed to light. Ohmic contacts are made along the edge. The surface layer of p-type material is externally thin so that light can penetrate to the junction.

### Operation:

The light rays pass through the glass plate and reaches the p-n junction. It creates new  $e^{-h\nu}$  hole pairs. These carriers move freely across the junction. It accumulates with the majority carriers. This gives rise to the potential across the junction. The terminal voltage developed across the cell is proportional to the intensity of the incident light. The voltage is 0.5v for Si cell and 0.1v for Ge cell.

## Applications:

Solar cells are used

1. To charge batteries
2. In space applications
3. In direct reading illumination meter.
4. In low resistance relays.

## ASTABLE MULTIVIBRATOR:

The astable multivibrator has two states, both are quasi-stable i.e. none of the states are stable. Without any trigger it changes its state.

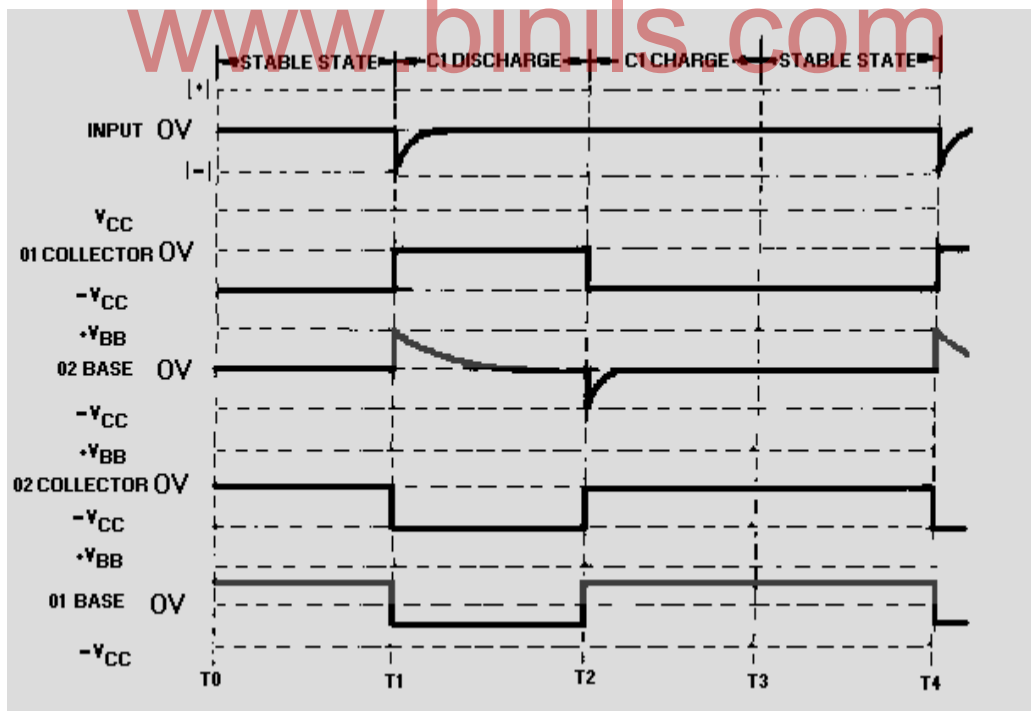
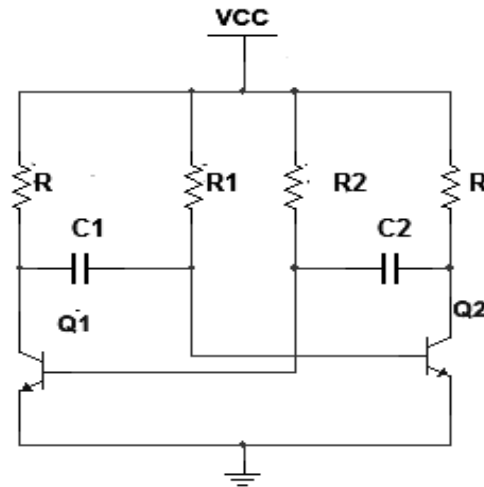

Q1 and Q2 are identical npn transistors. The collector resistances are equal to  $R_c$ . The collector of Q1 is coupled to the base of Q2 through C1. The collector of Q2 is coupled to the base of Q1 through C2. When the supply is switched on, let us assume Q2 is ON and Q1 is OFF. C1 starts charging towards  $V_{cc}$

through  $R_c$ ,  $C_1$  and  $Q_2$ . Finally voltage across  $C_2$  becomes equal to  $V_{cc}$  with proper polarity. At the same time  $C_2$  which is charged to  $V_{cc}$  in the earlier state, starts discharging through  $Q_2$ ,  $V_{cc}$ ,  $R_2, C_2$ .

At the start base of  $Q_1$  is at  $-V_{cc}$ . As  $C_2$  starts discharging, base of  $Q_1$  becomes less and less negative. Finally it becomes equal to the cut-in voltage of  $Q_1$ . Now  $Q_1$  starts conducting.  $Q_1$  becomes ON and at the same time  $Q_2$  becomes OFF. Now  $C_2$  starts charging through  $R_c$ ,  $C_2$  and  $Q_1$ .  $C_1$  starts discharging through  $V_{cc}$ ,  $R_1$ ,  $C_1$  and  $Q_1$ . Now because of  $C_1$ , base of  $Q_2$  becomes less negative. Finally it becomes equal to the cut-in voltage of  $Q_2$ . Now  $Q_2$  becomes on and  $Q_1$  OFF. The changes in the two states are automatic and without any external triggering signal.

**MONOSTABLE MULTIVIBRATOR:**

It has one stable state. When a trigger is applied, the circuit changes from stable to quasi stable state. After some time, it goes to original state.

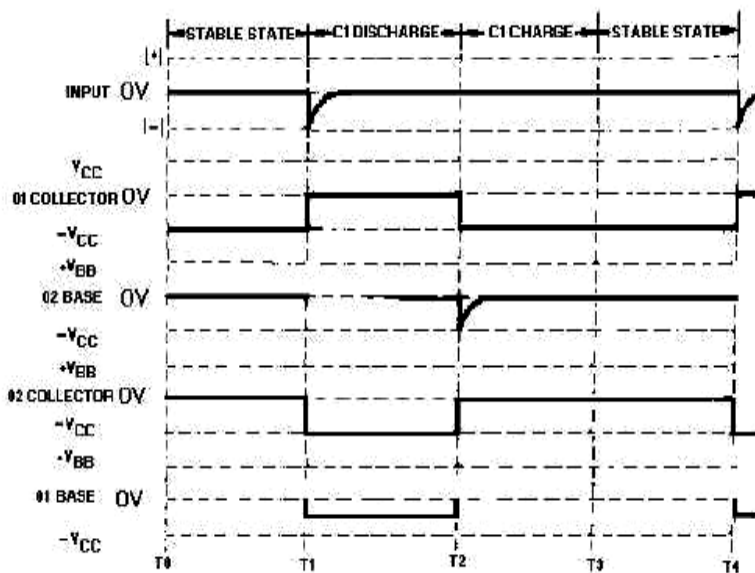
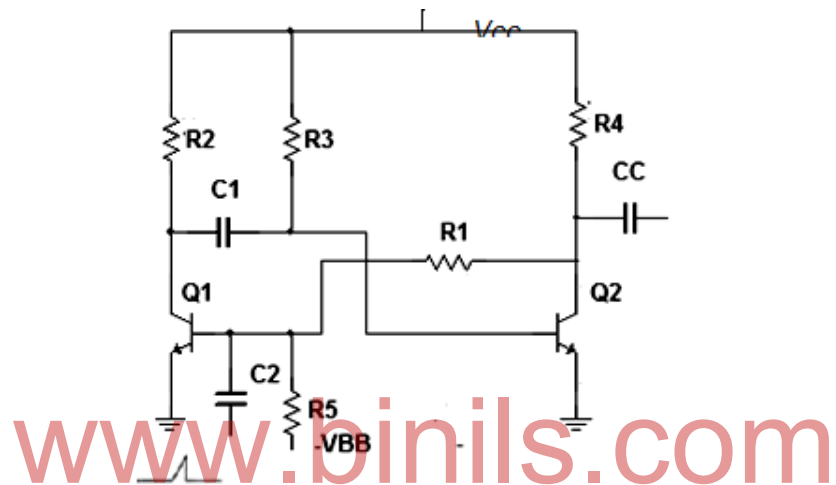

$Q_1$  and  $Q_2$  are identical transistors. The two collector resistors are equal to  $R_c$ . The collector of  $Q_2$  is coupled to the base of  $Q_1$  through  $R_1$ . The collector of  $Q_1$  is coupled to the base of  $Q_2$  through  $C_1$ .  $R_2$

and  $-V_{BB}$  are selected so that Q1 is OFF by reverse biasing it. Q2 is ON with the help of  $V_{CC}$  and R. Q2 ON and Q1 OFF is the stable state.

Positive triggering pulse is applied to the base of Q1 through C2. Q1 starts conducting. The collector voltage of Q1 ( $V_{c1}$ ) decreases. This is coupled to base of Q2 through C1. But voltage across C1 cannot change immediately. So forward bias of Q2 decreases. Hence collector current of Q2 decrease. The collector voltage of Q2 increases. It is applied to the base of Q1. This further increases the base voltage of Q1. Q1 is driven to conduction and Q2 becomes OFF. This is the quasi stable state.

The circuit will remain in this state for a time period of T. During this state C1 starts charging through the path  $V_{CC}$ , R2 and Q1. So the base voltage of Q2 increases. When this voltage reaches the cut in voltage of Q2, then Q2 starts conducting. Due to the regenerative action, Q2 is turned on. The circuit returns back to its stable state. The time period  $T = 0.69RC$ .

### BI-STABLE MULTIVIBRATOR:

It has two stable states. It remains in the stable state indefinitely. It requires an external trigger pulse to change from one stable state to other stable state.

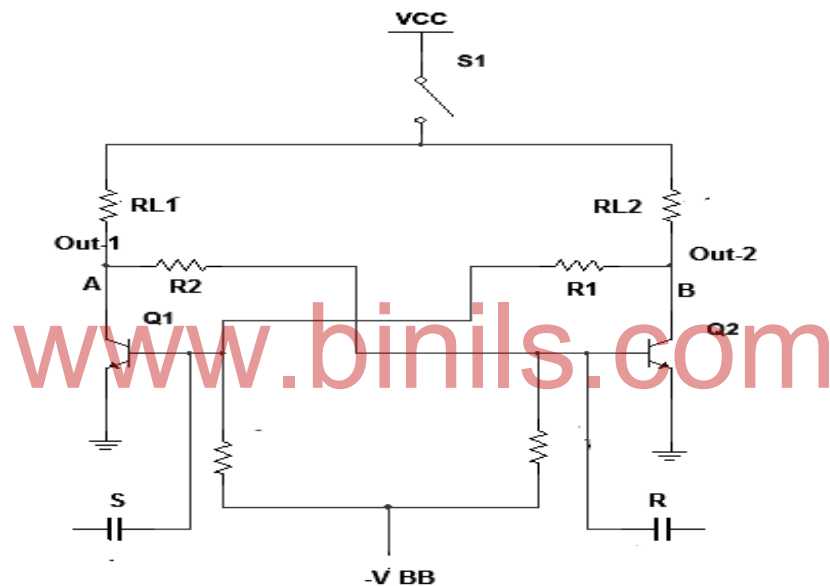

It uses two identical npn transistors. The collector of Q2 is coupled to the base of Q1 through R1. The collector of Q1 is coupled to the base of Q2 through R2. When the supply is switched on, any one of the transistors starts conducting. Let us assume Q2 starts conducting. Hence current drawn by Q2 is more than that of Q1.

Due to regenerative action, the current through Q2 keeps on increasing. The current through Q1 keeps on decreasing. Finally Q2 becomes ON and Q1 OFF. The circuit remains in this state. If a positive trigger pulse is applied at the base of Q1, it will drive Q1 to saturation and Q2 to cut-off. This is the second stable state. The circuit remains in this state though the applied pulse is removed. The change of states depends upon the applied pulse at the proper terminals.

## SCHMITT TRIGGER:

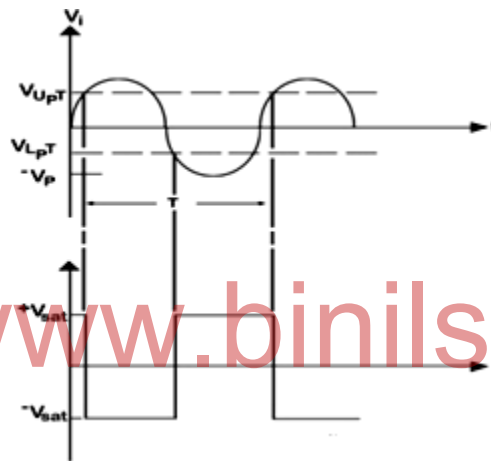
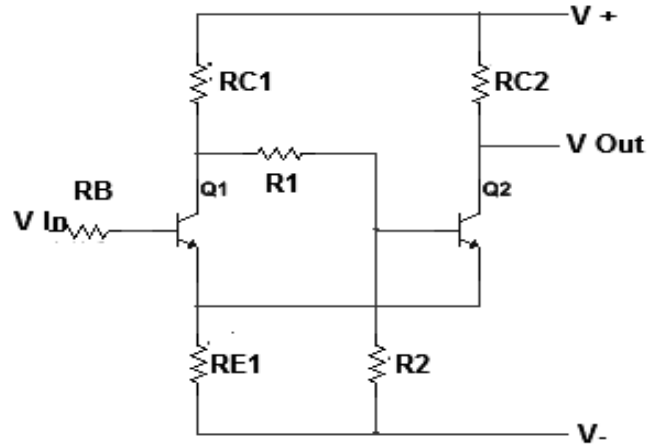

When the i/p is zero, Q2 is ON and Q1 is OFF. So the current  $I_{c2} = V_{cc} / (R_{c2} + R_e)$  flows in the circuit. The output =  $V_{cc} - I_{c2} * R_e$ . The voltage drop in  $R_e$  ( $I_{c2} * R_e$ ) reverse biases the base-emitter junction of Q1. So Q1 is in OFF state. When the i/p increases and goes above  $V_1 = (I_{c2} * R_e + V_{\gamma})$ , Q1 becomes ON. The o/p is equal to  $V_{cc}$ . Now a current  $I_{c1} = V_{cc} / (R_{c1} + R_e)$  flows in the circuit. The voltage drop in  $R_e = I_{c1} * R_e$ . When the i/p decreases and reaches  $V_2 = (I_{c1} * R_e + V_{\gamma})$ , Q1 becomes OFF and Q2 becomes ON. Thus the Schmitt trigger circuit converts a sine wave into a square wave.  $V_1$  is called upper trigger point and  $V_2$  is called lower trigger point.

### Applications:

1. Used to convert a sine wave into a square wave.
2. Used as an amplitude comparator.