

**GOVERNMENT OF TAMILNADU
DIRECTORATE OF TECHNICAL EDUCATION
CHENNAI – 600 025**

STATE PROJECT COORDINATION UNIT

Diploma in Electrical and Electronics Engineering

Course Code: 1020

M – Scheme

e-TEXTBOOK

on

ELECTRICAL DRIVES AND CONTROL

for

IV Semester DME

Convener for EEE Discipline:

Er.R.Anbukarasi ME.,

,
Principal,
Tamilnadu Polytechnic College,
Madurai, 625011.

www.binils.com

Team Members for Electrical drives and control

1. **Mrs.M. Jeraldin ahila,**
Lecturer, /EEE,
Government Polytechnic College,
Nagarkoil.
2. **Mr.D. Sabaripandiyam**
Lecturer/EEE
Government Polytechnic College,
Thiruthuraipoondi.
3. **Mr. S.kumaresan ,**
Lecturer/EEE
Government Polytechnic College,
Tuticorin.

Validated by

Dr.P.S.Manoharan
Associate Professor,
Department of Electrical and Electronics Engineering,
Thiagarajar College of Engineering, Madurai.

DETAILED SYLLABUS

32044- ELECTRICAL DRIVES & CONTROL (M - SCHEME)

UNIT-I:- DC CIRCUITS AND DC MACHINES

Definition- Electric current, voltage and resistance -Ohm's law and Kirchoff's law. Resistance in series and parallel and series, parallel – simple problems electromagnetism (definitions only) – magnetic flux, flux density magnetic field intensity, MMF, permeability, reluctance, Faraday's law of electromagnetic induction, electrical and mechanical units DC generators – construction, principle of operation, types and application. DC motors: - construction, principle of operation, types and application. Necessity of starters: Three point, four point starters.

UNIT-II:-AC CIRCUITS AND AC MACHINES

Fundamentals of AC voltage, and current – peak, average, RMS value of sine wave, frequency, time period, amplitude, power and power factor (definition only)- star and delta connection relationship between phase, line voltage and current in star and delta connections. Transformer: Principle of operation and construction – EMF equation (no definition)- losses in Transformer – efficiency – application. Alternator construction – principle of operation – types and applications. AC machine: AC motors- Principle of operation of single phase capacitor start and universal motor induction motor– applications Three phase induction motors – Squirrel cage and slip ring Induction motors (construction and working principle only) - application – speed control of 3 Φ Induction motor -Necessity of starters – DOL and star/delta starter

UNIT-III:- STEPPER AND SERVO MOTORS & DRIVES

PMDC, Stepper motor- construction and working principle and applications - Servo motor – types: brushless servo motor, permanent magnet servo motor construction and applications. Industrial drives- types, group drive, individual drive, multi motor drive, block diagram of Variable frequency drive , stepper motor drive: single stepping and half stepping. Servo drives. Electrical safety: - importance of earthing - electric shock: first aid, precautions - causes of accident and their preventive measures. Energy conservation.

UNIT-IV: POWER SUPPLIES AND LOGIC GATES

Diode – terminals: anode and cathode, forward biasing and reverse biasing – use of diode in rectifiers – half wave and full wave – necessity of filters- Regulated power supplies: IC voltage regulators – SMPS, UPS and Inverters – General description and their applications. Display devices – LED, 7 segments LED, LCD

Logic gates: Positive and negative logic, definition, symbol truth table, Boolean expression for OR, AND, NOT, NOR, NAND, EXOR AND EXNOR gates – Universal logic Gates: NAND, and NOR. V CONTROL ELEMENTS AND PLC Fuses – selection of fuse – necessity of fuse- fuse switch units.

UNIT-V:-CONTROL ELEMENTS AND PLC

Fuses – selection of fuse – necessity of fuse- fuse switch units. Sensors: Photo electric sensor, Inductive proximity sensors, Temperature sensors. Switches: Push button switch, selector switch, limit switch, pressure switch, temperature switch, float switch and reed switch. Relays – NO, NC – usage- bimetallic thermal overload relays. Contactors- usage – necessity of contactor- Solenoid type contactor Circuit breakers – Miniature case Circuit breaker (MCCB) and Miniature Circuit breaker (MCB), Oil Circuit breakers (OCB), Earth leakage circuit breaker (ELCB) Features of PLC-PLC Block diagram- PLC scan - Fixed and modular PLC Ladder logic-NO, NC contacts-Coils-AND, OR.

TEXT BOOKS:

- 1) A course in electrical engineering - B.L.Theraja - Multi Colour Edition, S Chand & Co, Reprint 2006
- 2) Control of Machines - S.K Bhattacharya, Brijinder Singh – New Age Publishers, Second Edition- Reprint 2010
- 3) Electronic Circuits & System- Analog and Digital – Y.N.Bapat - Tata Mc Graw Hill.

www.binils.com

REFERENCE BOOKS:

- 1) Electrical Technology – Hughes - 8th Edition, Pearson Education.
- 2) Electronic Device and Circuits- An introduction – Allen Mottershed - Prentice Hall of India.

www.binils.com

UNIT I

DC CIRCUITS AND DC MACHINES

1. DEFINITIONS

Current (I):

The flow of free electrons in any conductor is called Current. It is denoted by the letter I. The unit of current is ampere.

Resistance(R):

The opposition offered by a substance to the flow of electric current is called resistance. It is denoted by the letter 'R'. The unit of resistance is ohm(Ω).

1.1. OHM'S LAW:

Ohm's Law states that at constant temperature, the current flowing through a conductor is directly proportional to the potential difference across the conductor. Ohm's law is the law establishing the relation between voltage, current and resistance.

www.binils.com

$$V \propto I$$
$$V = IR$$

It can be expressed as,

$$\frac{V}{I} = R ; \frac{V}{R} = I$$

Where R is a constant and is called the resistance of the conductor.

1.3. CONNECTION OF RESISTANCES:

Resistances can be connected in the following three ways:

- (a) Series connection
- (b) Parallel connection
- (c) Series parallel connection

1.3.1. Resistance in Series:

A circuit is said to be in series when the current flowing through the resistances are same.

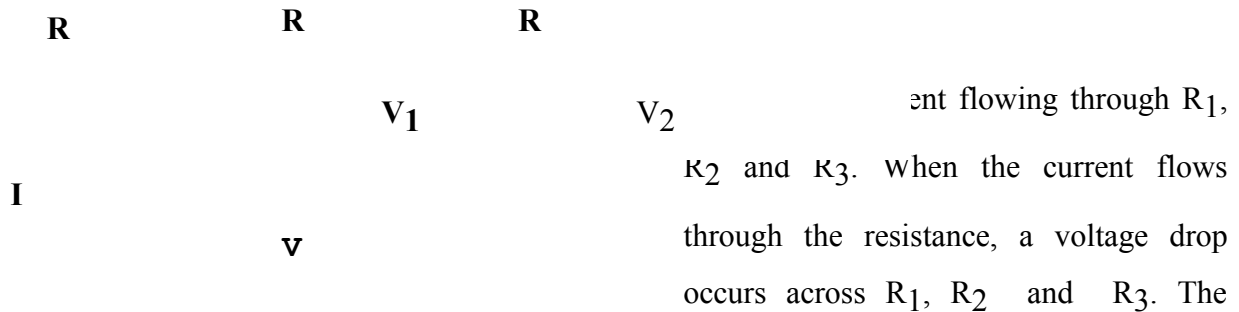

voltage drop can be calculated using ohm's law $V=IR$.

$$\text{Voltage drop across } R_1 = IR_1 = V_1$$

$$\text{Voltage drop across } R_2 = IR_2 = V_2$$

$$\text{Voltage drop across } R_3 = IR_3 = V_3$$

Total potential difference across the circuit = V

$$V = V_1 + V_2 + V_3$$

$$= IR_1 + IR_2 + IR_3$$

$$V = I (R_1 + R_2 + R_3)$$

$$\frac{V}{I} = R_1 + R_2 + R_3, \quad \frac{V}{I} = R$$

$$R = R_1 + R_2 + R_3$$

R is the total or equivalent resistance of the circuit. If two resistances are connected in series, then the equivalent resistance is equal to $R_1 + R_2$, i.e., Sum of individual resistance.

Problem: 1.1

In a circuit, three 5Ω resistors are connected in series. What is the total resistance of the circuit?

Solution:

5 Ω 5 Ω 5 Ω

Value of each resistances = 5 Ω

Total resistance $R_T =$

$$R_1 + R_2 + R_3$$

$$R_T = 15\Omega$$

Problem: 1.2

Find the resistance R in the circuit shown in fig.



www.binils.com

Solution:
 $I = 1\text{Amp}$

$$V = 20\text{v}$$

Total resistance

$$R_T = R + 5\Omega \dots\dots\dots$$

(1)

By ohm's law;

$$V = IR$$

$$R = \frac{V}{I} = \frac{20}{1} = 20 \Omega \dots\dots\dots (2)$$

(1)

and (2) should be equal

$$5 + R = 20$$

$$R = 20 - 5 = 15 \Omega$$

$$R = 15 \Omega$$

Problem: 1.3

In the circuit show in fig. Find the current the voltage drop across each resistor and the power dissipated in each resistor.

$$3 \Omega$$

$$4 \Omega$$

$$1 \Omega$$

$$V_1$$

$$V_2$$

Total resistance of the circuit $R_T =$

$$+20V$$

$$3+4+1$$

$$= 8 \Omega$$

Supply voltage $V = 20V$

$$\text{Circuit current } I = \frac{V}{R} = \frac{20}{8} = 2.5A$$

Voltage drop across 3Ω resistor $V_1 = IR_1$

$$V_1 = 2.5 \times 3$$

$$= 7.5 \text{ Volts}$$

Voltage drop across 4Ω resistor $V_2 = IR_2$

$$V_2 = 2.5 \times 4$$

$$= 10 \text{ Volts}$$

Voltage drop across 1Ω resistor $V_3 = IR_3$

$$V_3 = 2.5 \times 1$$

$$= 2.5 \text{ Volts}$$

Power dissipated in R_1 is $P_1 = I^2R_1$

$$= 2.5^2 \times 3$$

$$= 18.75 \text{ Watts}$$

Power dissipated in R_2 is $P_2 = I^2 R_2$

$$= 2.5^2 \times 4$$

$$= 25 \text{ Watts}$$

Power dissipated in R_3 is $P_3 = I^2 R_3$

$$= 2.5^2 \times 1$$

$$= 6.25 \text{ Watts}$$

Problem: 1.4

Find the voltage needed so that a current of 2 Amperes will flow through the series circuit as shown in fig

5 Ω 2A 4 Ω

+
V

1 Ω

Solution:

Total resistance in the circuit

$$R_T = R_1 + R_2 + R_3$$

$$R_T = 5 + 4 + 1$$

$$R_T = 10\Omega$$

$$I = 2\text{Amp}$$

$$V = IR_T = 2 \times 10 = 20 \text{ volts}$$

1.3.2. Resistances in Parallel:

In parallel connection the potential difference across all the resistor is the same, but the current in each is different.

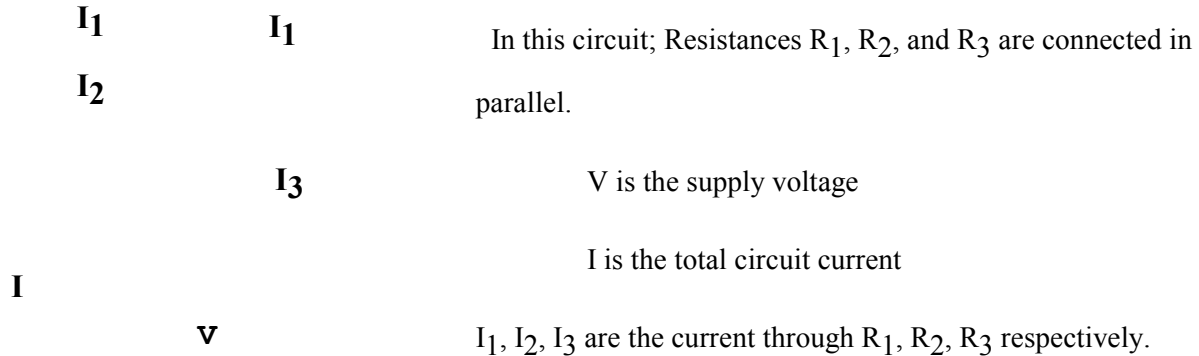

The total current in the circuit is the sum of the currents flowing through each resistances.

$$I = I_1 + I_2 + I_3$$

$$\text{Voltage drop across } R_1 = I_1 R_1 = V$$

$$\text{Voltage drop across } R_2 = I_2 R_2 = V$$

$$\text{Voltage drop across } R_3 = I_3 R_3 = V$$

$$I_1 = \frac{V}{R_1}, \quad I_2 = \frac{V}{R_2}, \quad I_3 = \frac{V}{R_3}$$

$$I = \frac{V}{R_1} + \frac{V}{R_2} + \frac{V}{R_3}$$

$$I = V \left[\frac{1}{R_1} + \frac{1}{R_2} + \frac{1}{R_3} \right]$$

$$\frac{I}{V} = \frac{1}{R_1} + \frac{1}{R_2} + \frac{1}{R_3}$$

$$\frac{1}{R} = \frac{1}{R_1} + \frac{1}{R_2} + \frac{1}{R_3}$$

In the parallel circuit, reciprocal of equivalent resistance is the sum of reciprocal of individual resistance.

Note:

For two resistance connected in parallel

$$\frac{1}{R} = \frac{1}{R_1} + \frac{1}{R_2} = \frac{R_1 + R_2}{R_1 R_2}$$

www.binils.com

$$R = \frac{R_1 R_2}{R_1 + R_2}$$

Problem: 1-5

Find the total resistance when 5 Ω and 3 Ω are connected in parallel.

5 Ω

3 Ω

Solution:

$$R = \frac{R_1 R_2}{R_1 + R_2} = \frac{5 \times 3}{5 + 3} = \frac{15}{8} = 1.875 \Omega.$$

Problem: 1-6

Find the value of total current and branch current in the given circuit if voltage applied is 36 volt.

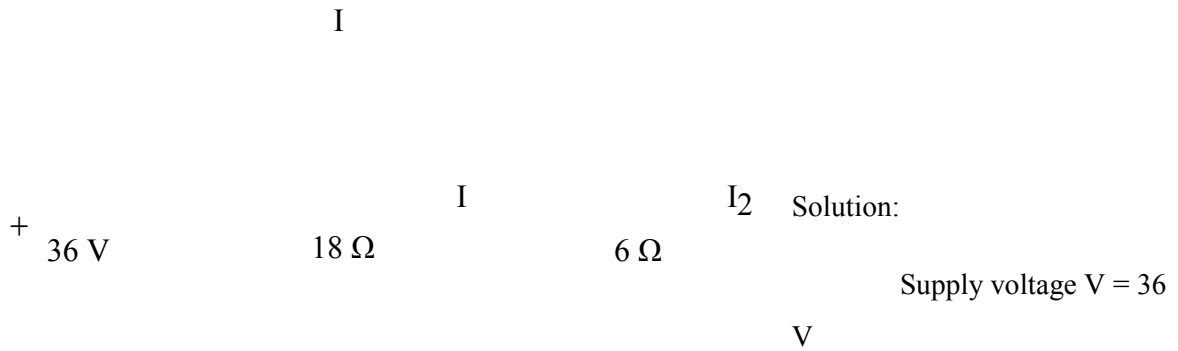

Current through 18 Ω resistor $I_1 = \frac{V}{R_1}$

www.binils.com

$$I_1 = \frac{36}{18} = 2 \text{ Amp}$$

Current through 6Ω resistor $I_2 = \frac{V}{R_2}$

$$I_2 = \frac{36}{6} = 6 \text{ Amp}$$

Total current $I = I_1 + I_2$

$$= 2 + 6$$

$$= 8 \text{ Amp}$$

Problem: 1-7

In the circuit shown in fig find the total resistance and the current through each branch.

5 Ω

10 Ω

15 Ω

20 Ω

40

I_1

I_2

I_3 resistance R_T

I_4

$$\frac{1}{R_T} = \frac{1}{R_1} + \frac{1}{R_2} + \frac{1}{R_3} + \frac{1}{R_4}$$

$$= \frac{1}{5} + \frac{1}{10} + \frac{1}{15} + \frac{1}{20}$$

$$\frac{1}{R_T} = 0.416$$

$$R_T = \frac{1}{0.416} = 2.4 \Omega$$

$$\text{Current through } 5 \Omega \text{ resistor } I_1 = \frac{V}{R_1} = \frac{40}{5} = 8A$$

$$\text{Current through } 10 \Omega \text{ resistor } I_2 = \frac{V}{R_2} = \frac{40}{10} = 4A$$

$$\text{Current through } 15 \Omega \text{ resistor } I_3 = \frac{V}{R_3} = \frac{40}{15} = 2.66A$$

$$\text{Current through } 20 \Omega \text{ resistor } I_4 = \frac{V}{R_4} = \frac{40}{20} = 2A$$

1.3.3. Series Parallel circuit:

The circuit contains series and parallel combination of resistances is known as series parallel circuits.



In this circuit resistance R₃ is connected in series with the parallel combination of resistance R₁ and R₂.

R₁ & R₂ resistance are connected in parallel.

$$R_p = \frac{R_1 R_2}{R_1 + R_2}$$



R_p and R₃ are connected in series

$$R_{eq} = R_T = \frac{R_1 R_2}{R_1 + R_2} + R_3$$

Current through R_1 ; $I_1 = I \left(\frac{R_2}{R_1 + R_2} \right)$

Current through R_2 ; $I_2 = I \left(\frac{R_1}{R_1 + R_2} \right)$

Problem: 1-8

Find the current and the voltage across 10Ω in the given circuit.

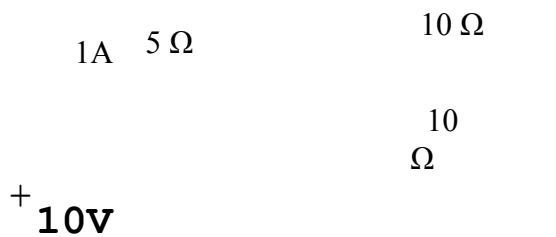

Solution:

In this circuit 10Ω resistors are connected parallel

$$R_p = \frac{10 \times 10}{10 + 10} = 5 \Omega$$



$$\text{Total resistance } R_T = 5 + R_p = 5 + 5 =$$

$$10 \Omega$$

$$I = \frac{V}{R_T} = \frac{10}{10} = 1 \text{ Amp}$$

Current through 5Ω resistance = 1A

$$\text{Current through } 10 \Omega \text{ resistance} = 1 \times \left(\frac{10}{10 + 10} \right) = 0.5A$$

$$\text{Total current } I = I_1 + I_2 = 0.5 + 0.5 = 1\text{ A}$$

Problem: 1-9

A resistor of $5\ \Omega$ resistance is connected in series with a parallel circuit comprising of $1\ \Omega$, $2\ \Omega$ and $4\ \Omega$ respectively. A battery of e.m.f $24\ \text{V}$ is connected across the circuit. Draw the circuit diagram and find the total resistance and total current in the circuit.

Solution:

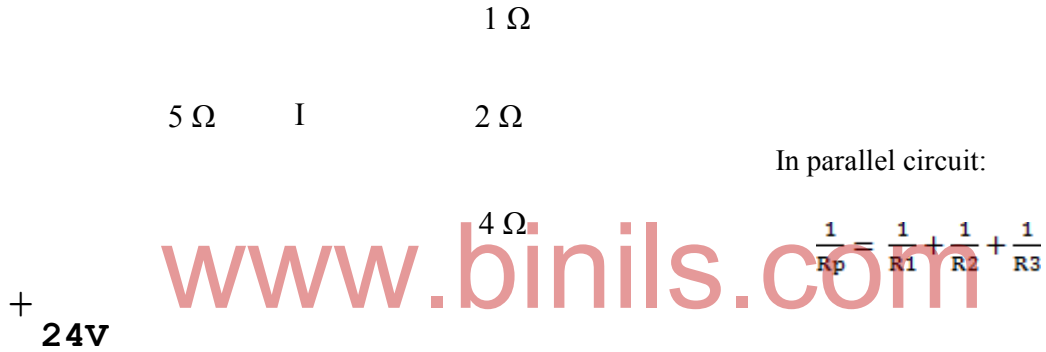

In parallel circuit:

$$\frac{1}{R_p} = \frac{1}{R_1} + \frac{1}{R_2} + \frac{1}{R_3}$$

$1\ \Omega$, $2\ \Omega$ and $4\ \Omega$ resistor are connected in parallel.

$$\frac{1}{R_p} = \frac{1}{1} + \frac{1}{2} + \frac{1}{4}$$

$$\frac{1}{R_p} = 1.75$$

$$R_p = \frac{1}{1.75} = 0.57\ \Omega$$

$$\text{Total resistance } R_T = 5 + R_p = 5 + 0.57 = 5.57\ \Omega$$

$$R_T = 5.57\Omega$$

$$\text{Total current } I = \frac{V}{R_T} = \frac{24}{5.57} = 4.31\text{A}$$

$$I = 4.31\text{A}$$

Problem: 1-10

A resistance of $6\ \Omega$ is connected in series with a parallel branch consisting of $10\ \Omega$ and $15\ \Omega$. If a battery of $12\ \text{V}$ is connected to the complete circuit. Calculate the total current and branch current.

Solution:

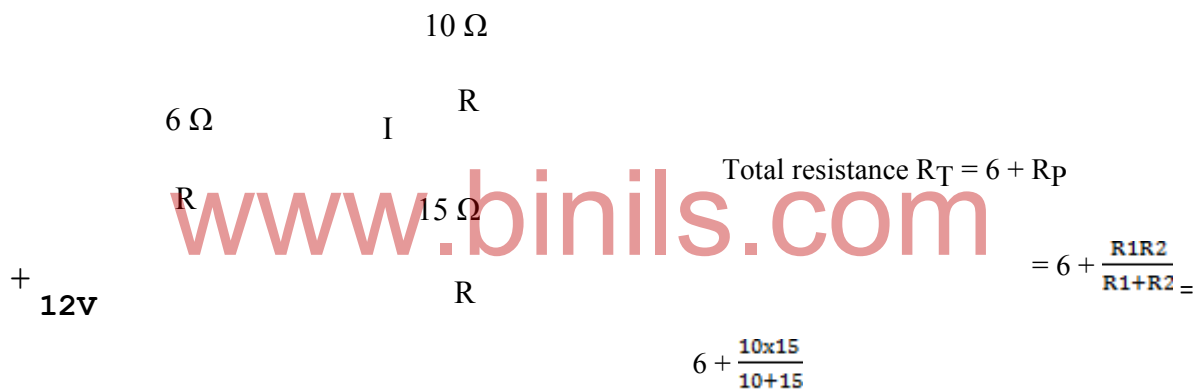

$$R_T = 6 + \frac{150}{25} = 6 + 6 = 12\ \Omega$$

$$\text{Total current } I = \frac{V}{R_T} = \frac{12}{12} = 1\text{Amp}$$

$$\text{Current through the } 10\Omega \text{ resistor } I_1 = I \left(\frac{R_3}{R_2 + R_3} \right)$$

$$I_1 = I \left(\frac{15}{10 + 15} \right)$$

$$I_1 = 0.6\text{Amp}$$

Current through the 15Ω resistor $I_2 = I \left(\frac{R_2}{R_2+R_3} \right)$

$$I_2 = I \left(\frac{10}{10+15} \right)$$

$$I_2 = 0.4\text{Amp}$$

www.binils.com

KIRCHHOFF'S LAWS:

Sometimes complicated circuit cannot be simplified into a series (or) parallel or series parallel circuit and cannot be solved by applying ohm's law. Such circuits may be solved by applying Kirchhoff's laws.

The two basic laws which concern the voltage across and current through the elements of a network are,

First law: Kirchhoff's current law (or) Point law

Second law: Kirchhoff's voltage law (or) Mesh law

First law: Kirchhoff's current law (or) Point law:

The algebraic sum of current flowing towards a junction in an electric circuit is zero.

(or)

The sum of the incoming currents in an electric circuit is equal to the sum of the outgoing currents.

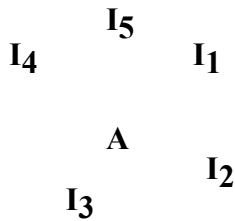

Fig.

Explanation:

Node or Junction is a place of meeting of electrical conductors. There conductors carrying current I_1 , I_2 , I_3 , I_4 and I_5 meeting at point 'A' shown in fig. if we take '+' sign for the currents entering (towards) the node and '-' sign for the current leaving (away from) the junction.

$$(I_1) + (-I_2) + (-I_3) + (I_4) + (-I_5) = 0$$

(or)

$$I_1 + I_4 = I_2 + I_3 + I_5$$

www.binils.com

Sum of currents	Sum of currents
entering the junction	leaving the junction
=	

Second law: Kirchhoff's voltage law (or) Mesh law:

The algebraic sum of all voltages around a closed path at any instant is zero.

i.e., Algebraic sum of emf's + Algebraic sum of voltage drops = 0

SIGN OF EMF'S AND VOLTAGE DROPS:

For e.m.f

If we go from the positive terminal of a battery to the negative terminal, the emf should be assigned negative sign. On the other hand, if we go from the negative terminal of the battery to the positive terminal, there is a rise in potential; the emf should be given positive sign.

E

E

Fall in voltage (-E)

Rise in voltage (+E)

For voltage drops:

If we go through the resistor in the same direction as the current, there is a fall in potential, because currents flow from high potential to lower potential. Hence this voltage drop should be given negative sign. On the other hand, if we go opposite to the current flow, there is a rise in potential and the voltage drop should be given positive sign.

www.binils.com

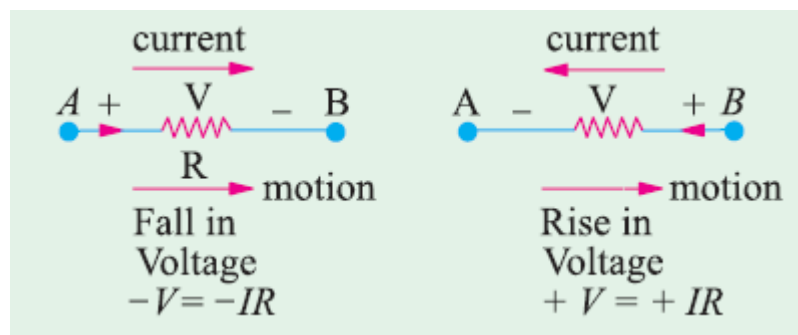
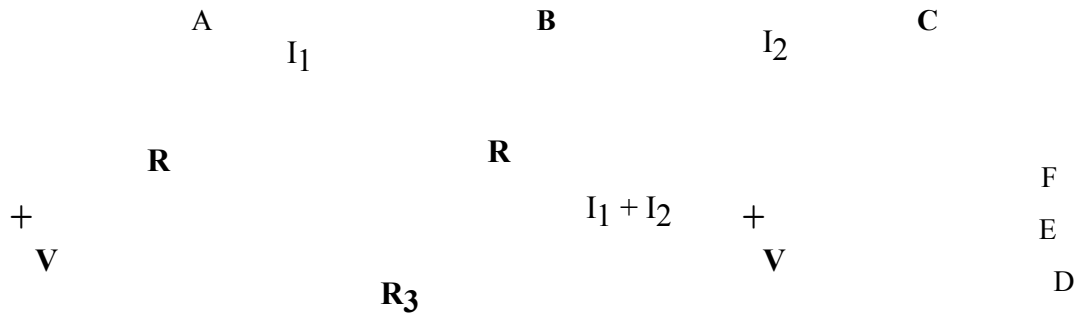

Illustration:



- (i) The magnitude of current in any branch of circuit can be found by applying Kirchhoff's first law(current law).
- (ii) At junction B, for the above figure, the incoming currents to the junction are I_1 and I_2 and the outgoing current is equal to I_1+I_2 .
- (iii) Kirchhoff's voltage law can be applied to the closed loop of the circuit.

In the closed loop ABEFA

$$-I_1R_1-(I_1+I_2)R_3+V_1=0$$

$$-I_1R_1-I_1R_3-I_2R_3+V_1=0$$

$$-I_1R_1-I_1R_3-I_2R_3 = V_1 \text{-----> (1)}$$

In the closed loop BCDEB,

$$(I_1+I_2) R_3+ I_2R_2-v_2=0$$

$$I_1R_3+I_2R_3+I_2R_2-V_2=0$$

$$I_1R_3+I_2R_3+I_2R_2=V_2 \text{-----> (2)}$$

In the closed loop ABCDEFA

$$-I_1R_1+I_2R_2+V_1-V_2=0$$

$$-I_1R_1+I_2R_2=V_1-V_2 \text{-----> (3)}$$

Solve the equation for I_1 and I_2

Problem:

Find the current through 3 Ω resistor in the fig:

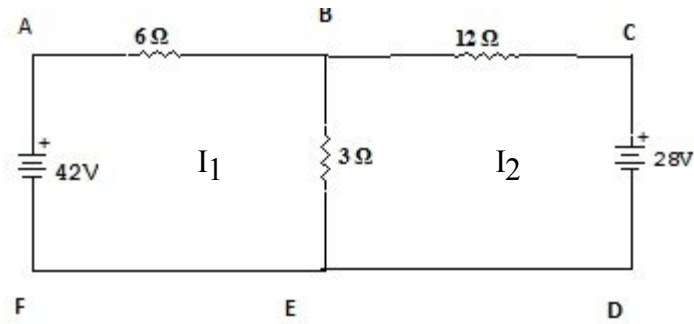

Solution:

Let I_1 and I_2 be the currents through 6 Ω and 12 Ω respectively.

6Ω	12Ω	
I_1	I_2	In the closed loop ABEFA
$+$	$I_1 + I_2$	
$42V$	3Ω	$+$ $28V$
		$-6I_1 - 3(I_1 + I_2) + 28 = 0$
		$2 = 0$

$$-6I_1 - 3I_1 - 3I_2 = -42 \text{ -----} > (1)$$

In the closed loop ABCDEFA

$$-6I_1 + 12I_2 + 42 - 28 = 0$$

$$-6I_1 + 12I_2 = -14 \text{ -----} > (2)$$

$$(1) \times 4 \text{ -----} > -36I_1 - 12I_2 = -168 \text{ -----} > (3)$$

$$(2) \text{ -----} > -6I_1 + 12I_2 = -14$$

$$(2) + (3) \text{ -----} > -42I_1 = -182$$

$$I_1 = 4.33 \text{ A}$$

Substitute the value of I_1 in equation (1)

We get:

$$-9(4.33)-3I_2=-42$$

$$-39-3I_2=-42$$

$$-3I_2=-3$$

$$I_2 = -3 / -3 = 1\text{A}$$

$$I_2 = 1\text{A}$$

Current through 3 Ω resistor is $I_1+I_2= 4.33+1 = 5.33$ Amps

Problem .

What is the value of unknown resistance R in fig if the the voltage drop across 500 Ω resistance is 2.5 volts.

www.binils.com

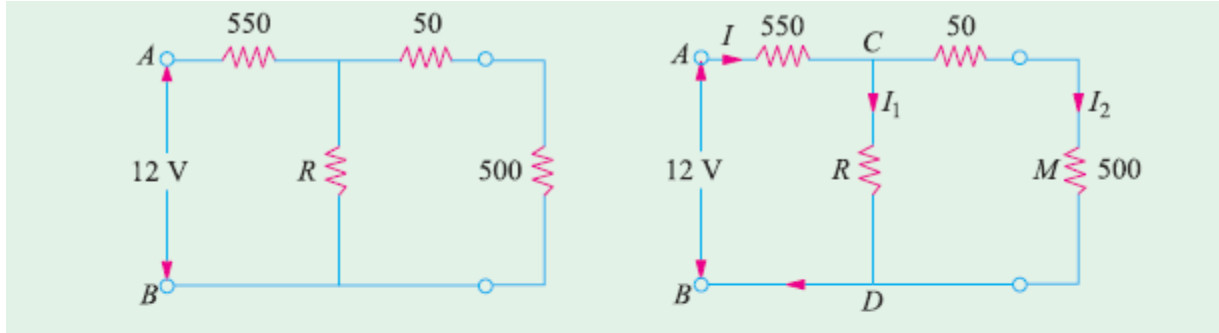

Fig.

Solution. By direct proportion, drop on $50\ \Omega$ resistance $= 2.5 \times 50/500 = 0.25\ \text{V}$

$$\text{Drop across CMD or CD} = 2.5 + 0.25 = 2.75\ \text{V}$$

$$\text{Drop across } 550\ \Omega \text{ resistance} = 12 - 2.75 = 9.25\ \text{V}$$

$$I = 9.25/550 = 0.0168\ \text{A}, I_2 = 2.5/500 = 0.005\ \text{A}$$

$$I_1 = 0.0168 - 0.005 = 0.0118\ \text{A}$$

$$\therefore 0.0118 = 2.75/R; \quad R = 233\ \Omega$$

www.binils.com

ELECTROMAGNETISM

Electromagnetism is the study of magnetic fields produced by conductors carrying current.

MAGNETIC FLUX

For a uniform magnetic field of density B teslas, the flux Φ passing normally (i.e., at right angles) through a plane of surface area $a\ \text{m}^2$ is measured in webers(Wb). It was given by

$$\Phi = Ba \text{ webers(Wb)}$$

$$B = \Phi / a \text{ teslas}$$

$$\text{Where } 1 \text{ tesla} = 1 \text{ Wb/m}^2$$

$$1 \text{ T} = 1 \text{ Wb/m}^2$$

FLUX DENSITY

It is defined as the normal flux per unit area. It is denoted as D .

$$D = \Phi/A \text{ Coulombs per m}^2$$

Where Φ flux in coulombs

A is area in m^2

MAGNETIC FIELD INTENSITY

Magnetic field intensity is defined as the magneto motive force per unit length of the magnetic flux path. Its symbol is H.

Magnetic field intensity = Magneto motive force/Mean length of magnetic path

$$H = F/l = IN/l \text{ A/m}$$

Where l is the length of the magnetic circuit in meter

I is the current flowing through the conductor

N is the number of turns

Magnetic field intensity is also called magnetic field strength or magnetising force.

MAGNETO MOTIVE FORCE(M.M.F)

Flux is produced around any current carrying any coil. In order to produce the required flux density, the coil should have the correct number of turns. The product of the current and the number of turns is defined as the coil magneto motive force(MMF).

If I=current through the coil (A)

N= Number of turns in the coil

Magneto motive force= Current×Turns

$$\text{MMF } F = IN \text{ A}$$

RELUCTANCE

The opposition offered by a magnetic circuit to the establishment of magnetic flux is called the reluctance of the magnetic circuit. The reluctance (Symbol S) is directly proportional to the length and inversely proportional to the area of cross section of the magnetic path.

S is directly proportional to l/a

$$S = l/\mu_0\mu_r a$$

PERMEABILITY

It is defined as measure of the ability of a material to alter the magnetic field in the area that it occupies.

FARADAY'S LAW OF ELECTROMAGNETIC INDUCTION

There are two principle laws of electromagnetic induction, known as faraday's laws.

These two laws may be stated as follows:

FIRST LAW:

Whenever a conductor cuts a magnetic flux an emf is induced in that conductor.

(or)

Whenever there is a change in magnetic flux linkage in a circuit a voltage is induced in it.

SECOND LAW:

The magnitude of emf induced in the coil is equal to the rate of change of flux that linkages with the coil. The flux linkage of the coil is the product of number of turns in the coil and flux associated with the coil.

$$e = N \frac{d\phi}{dt} \text{ volt}$$

dt

ELECTRICAL AND MECHANICAL UNITS

DC Generator

A dc generator is an electrical machine which converts mechanical energy into direct current electricity. This energy conversion is based on the principle of production of dynamically induced emf. This article outlines basic construction and working of a DC generator.

Construction of a DC machine:

A DC generator can be used as a DC motor without any constructional changes and vice versa is also possible. Thus, a DC generator or a DC motor can be broadly termed as a DC machine. These basic constructional details are also valid for the construction of a DC motor. Hence, let's call this point as construction of a DC machine instead of just 'construction of a dc generator'.

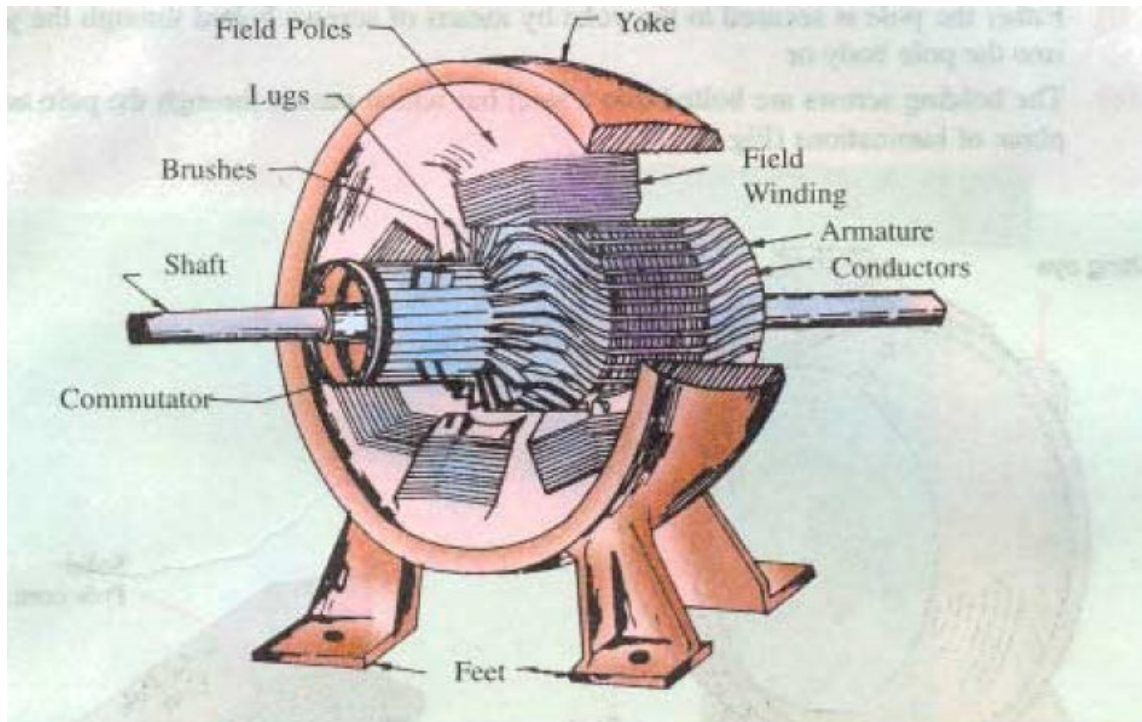

The above figure shows the constructional details of a simple DC machine. A DC machine consists of two basic parts; stator and rotor. Basic constructional parts of a DC machine are described below.

1. Yoke: The outer frame of a dc machine is called as yoke. It is made up of cast iron or steel. It not only provides mechanical strength to the whole assembly but also carries the magnetic flux produced by the field winding.
2. Poles and pole shoes: Poles are joined to the yoke with the help of bolts or welding. They carry field winding and pole shoes are fastened to them. Pole shoes serve two purposes; (i) they support field coils and (ii) spread out the flux in air gap uniformly.
3. Field winding: They are usually made of copper. Field coils are former wound and placed on each pole and are connected in series. They are wound in such a way that, when energized, they form alternate North and South poles.

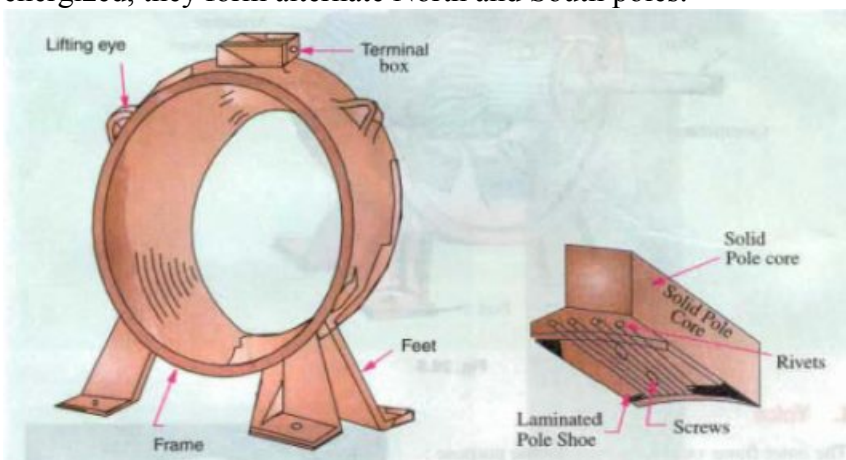



Armature core (rotor)

4. Armature core: Armature core is the rotor of the machine. It is cylindrical in shape with slots to carry armature winding. The armature is built up of thin laminated circular steel disks for reducing eddy current losses. It may be provided with air ducts for the axial air flow for cooling purposes. Armature is keyed to the shaft.
5. Armature winding: It is usually a former wound copper coil which rests in armature slots. The armature conductors are insulated from each other and also from the armature core. Armature winding can be wound by one of the two methods; lap winding or wave winding. Double layer lap or wave windings are generally used. A double layer winding means that each armature slot will carry two different coils.
6. Commutator and brushes: Physical connection to the armature winding is made through a commutator-brush arrangement. The function of a commutator, in a dc generator, is to collect the current generated in armature conductors. Whereas, in case of a dc motor, commutator helps in providing current to the armature conductors. A commutator consists of a set of copper segments which are insulated from each other. The number of segments is equal to the number of armature coils. Each segment is connected to an armature coil and the commutator is keyed to the shaft. Brushes are usually made from carbon or graphite. They rest on commutator segments and slide on the segments when the commutator rotates keeping the physical contact to collect or supply the current.



Commutator

Working principle of a DC generator:

According to Faraday's laws of electromagnetic induction, whenever a conductor is placed in a varying magnetic field (OR a conductor is moved in a magnetic field), an emf (electromotive force) gets induced in the conductor. The magnitude of induced emf can be calculated from the emf equation of dc generator. If the conductor is provided with the closed path, the induced current will circulate within the path. In a DC generator, field coils produce an electromagnetic field and the armature conductors are rotated into the field. Thus, an electromagnetically induced emf is generated in the armature conductors. The direction of induced current is given by Fleming's right hand rule.

Need of a Split ring commutator:

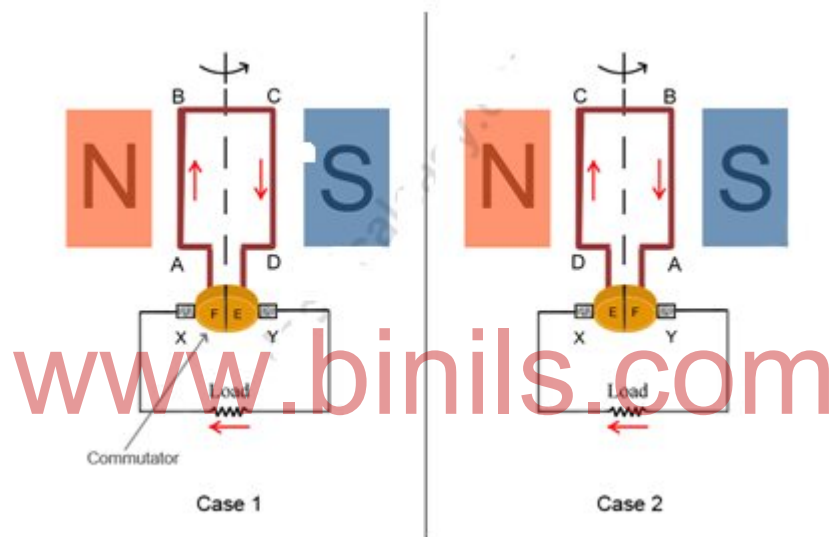

Where E_1 and E_2 are the voltages and N_1 , N_2 are the number of turns in the primary and the secondary windings respectively.

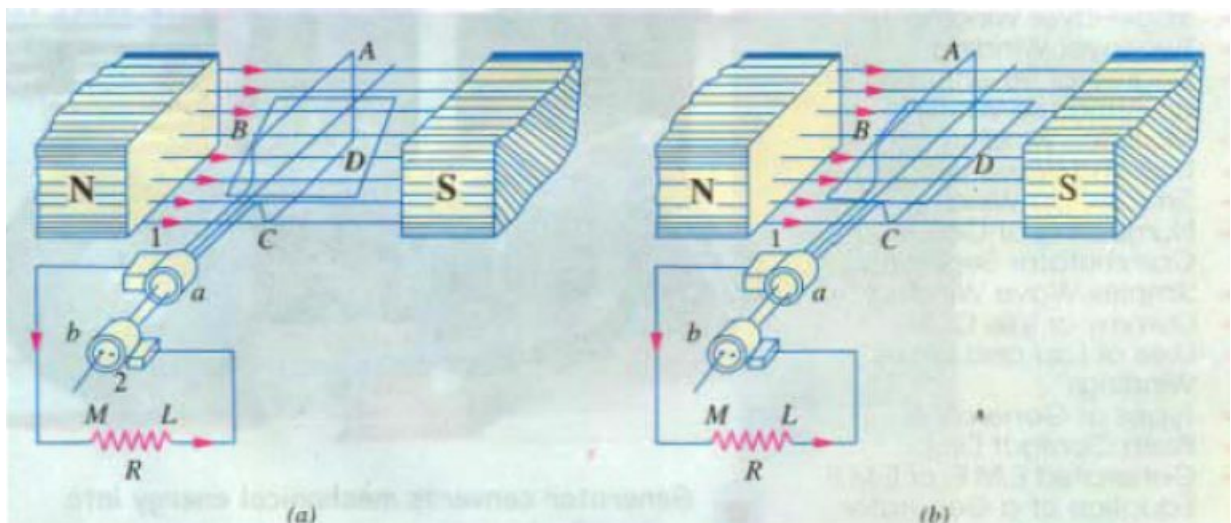

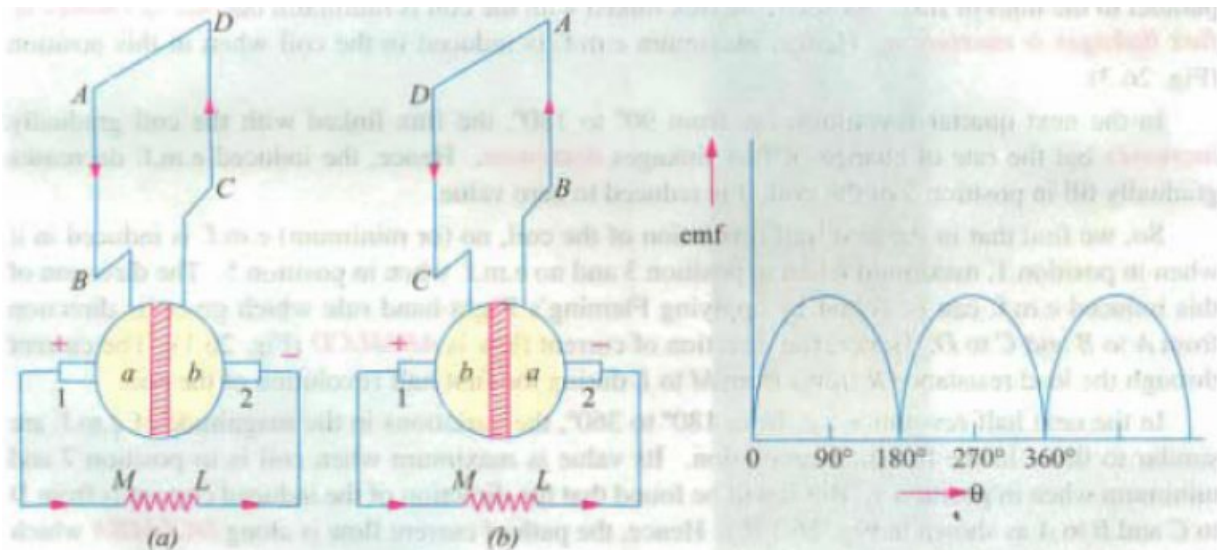
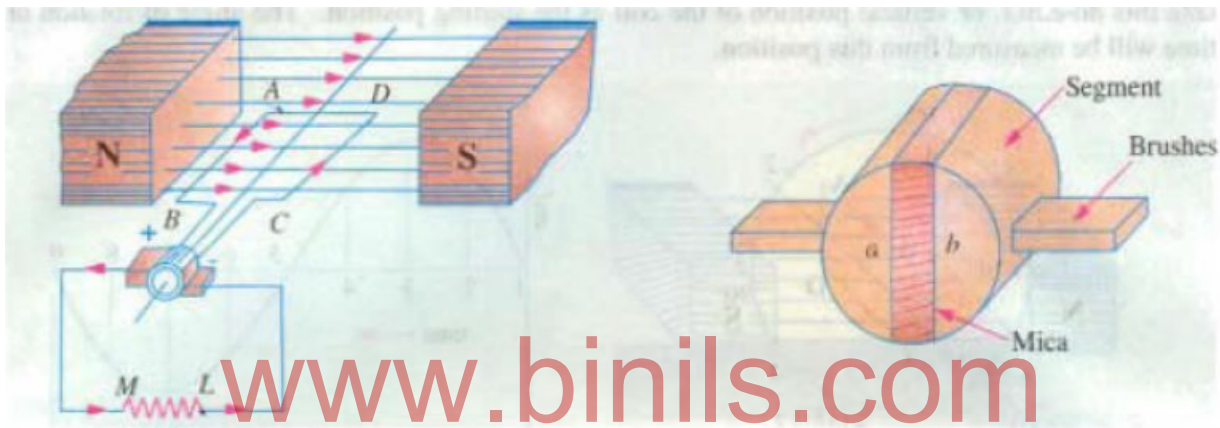
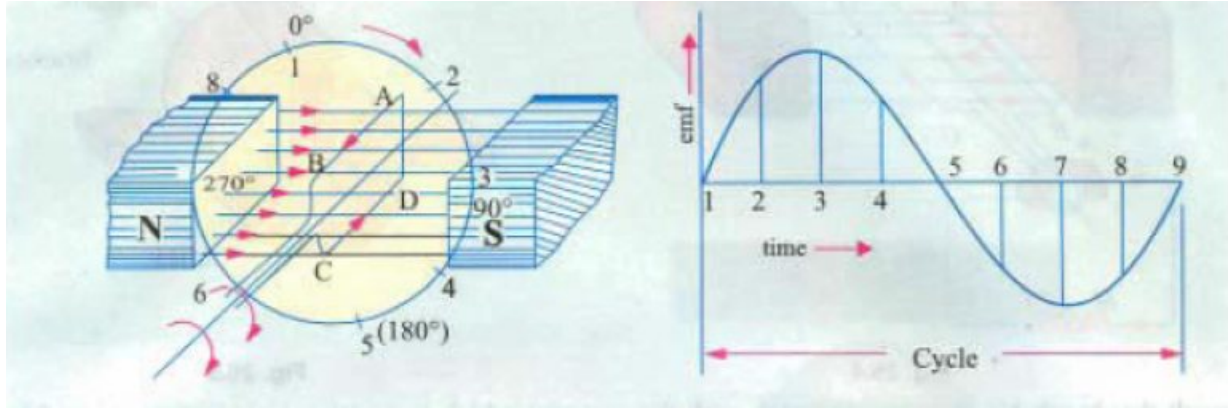

According to Fleming's right hand rule, the direction of induced current changes whenever the direction of motion of the conductor changes. Let's consider an armature rotating clockwise and a conductor at the left is moving upward. When the armature completes a half rotation, the direction of motion of that particular conductor will be reversed to downward. Hence, the

direction of current in every armature conductor will be alternating. If you look at the above figure, you will know how the direction of the induced current is alternating in an armature conductor. But with a split ring commutator, connections of the armature conductors also get reversed when the current reversal occurs. And therefore, we get unidirectional current at the terminals.

Types of a DC generator:

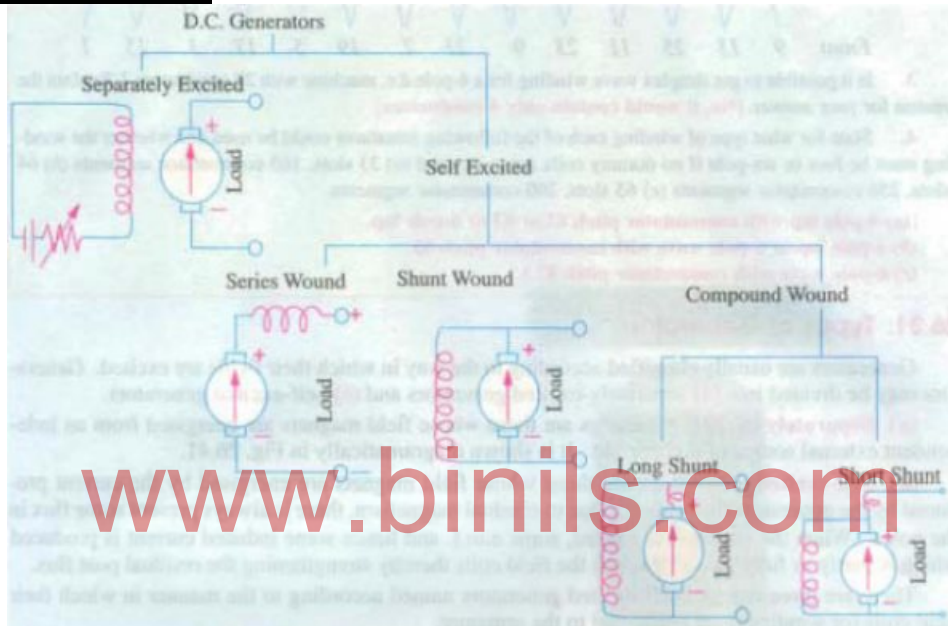

DC generators can be classified in two main categories, viz;

- (i) Separately excited and
- (ii) Self - excited .
 - (i) Separately excited: In this type, field coils are energized from an independent external DC source .
 - (ii) Selfexcited: In this type, field coils are energized from the current produced by the generator itself. Initial emf generation is due to residual magnetism in field poles. The generated emf causes a part of current to flow in the field coils, thus strengthening the field flux and thereby increasing emf generation. Self excited dc generators can further be divided into three types -
 - (a) Series wound - field winding in series with armature winding
 - (b) Shunt wound - field winding in parallel with armature winding
 - (c) Compound wound - combination of series and shunt winding.

Classifications of DC machines : (DC Motors and DC Generators)

Each DC machine can act as a generator or a motor. Hence, this classification is valid for both: DC generators and DC motors. DC machines are usually classified on the basis of their field

excitation method. This makes two broad categories of dc machines; (i) Separately excited and (ii) Self-excited.

- Separately excited: In separately excited dc machines, the field winding is supplied from a separate power source. That means the field winding is electrically separated from the armature circuit. Separately excited DC generators are not commonly used because they are relatively expensive due to the requirement of an additional power source or circuitry. They are used in laboratories for research work, for accurate speed control of DC motors with Ward-Leonard system and in few other applications where self-excited DC generators are unsatisfactory. In this type, the stator field flux may also be provided with the help of permanent magnets (such as in the case of a permanent magnet DC motors). A PMDC motor may be used in a small toy car.
- Self-excited: In this type, field winding and armature winding are interconnected in various ways to achieve a wide range of performance characteristics (for example, field winding in series or parallel with the armature winding). In self-excited type of DC generator, the field winding is energized by the current produced by themselves. A small amount of flux is always present in the poles due to the residual magnetism. So, initially, current induces in the armature conductors of a dc generator only due to the residual magnetism. The field flux gradually increases as the induced current starts flowing through the field winding.

Self-excited machines can be further classified as –

- Series wound – In this type, field winding is connected in series with the armature winding. Therefore, the field winding carries whole load current (armature current). That is why series winding is designed with few turns of thick wire and the resistance is kept very low (about 0.5 Ohm).
- Shunt wound – Here, field winding is connected in parallel with the armature winding. Hence, the full voltage is applied across the field winding. Shunt winding is made with a large number of turns and the resistance is kept very high (about 100 Ohm). It takes only small current which is less than 5% of the rated armature current.
- Compound wound – In this type, there are two sets of field winding. One is connected in series and the other is connected in parallel with the armature winding. Compound wound machines are further divided as -
 - Short shunt – field winding is connected in parallel with only the armature winding
 - Long shunt – field winding is connected in parallel with the combination of series field winding and armature winding

Applications of DC Generators

Applications of Separately Excited DC Generators

These types of DC generators are generally more expensive than self-excited DC generators because of their requirement of separate excitation source. Because of that their applications are restricted. They are generally used where the use of self-excited generators are unsatisfactory.

1. Because of their ability of giving wide range of voltage output, they are generally used for testing purpose in the laboratories.
2. Separately excited generators operate in a stable condition with any variation in field excitation. Because of this property they are used as supply source of DC motors, whose speeds are to be controlled for various applications. Example- Ward Leonard Systems of speed control.

Applications of Shunt Wound DC Generators

The application of shunt generators are very much restricted for its dropping voltage characteristic. They are used to supply power to the apparatus situated very close to its position. These type of DC generators generally give constant terminal voltage for small distance operation with the help of field regulators from no load to full load.

1. They are used for general lighting.
2. They are used to charge battery because they can be made to give constant output voltage.
3. They are used for giving the excitation to the alternators.
4. They are also used for small power supply.

Applications of Series Wound DC Generators

These types of generators are restricted for the use of power supply because of their increasing terminal voltage characteristic with the increase in load current from no load to full load. We can clearly see this characteristic from the characteristic curve of series wound generator. They give constant current in the dropping portion of the characteristic curve. For this property they can be used as constant current source and employed for various applications.

1. They are used for supplying field excitation current in DC locomotives for regenerative braking.
2. This types of generators are used as boosters to compensate the voltage drop in the feeder in various types of distribution systems such as railway service.
3. In series arc lightening this type of generators are mainly used.

Applications of Compound Wound DC Generators

Among various types of DC generators, the compound wound DC generators are most widely used because of its compensating property. We can get desired terminal voltage by compensating the drop due to armature reaction and ohmic drop in the line. Such generators have various applications.

1. Cumulative compound wound generators are generally used lighting, power supply purpose and for heavy power services because of their constant voltage property. They are mainly made over compounded.
2. Cumulative compound wound generators are also used for driving a motor.
3. For small distance operation, such as power supply for hotels, offices, homes and lodges, the flat compounded generators are generally used.
4. The differential compound wound generators, because of their large demagnetization armature reaction, are used for arc welding where huge voltage drop and constant current is required.

Types of DC Generators

Separately Excited DC Generator

A circuit diagram of separately excited DC generator is shown in figure. I_a = Armature current I_L = Load current V = Terminal voltage E_g = Generated emf

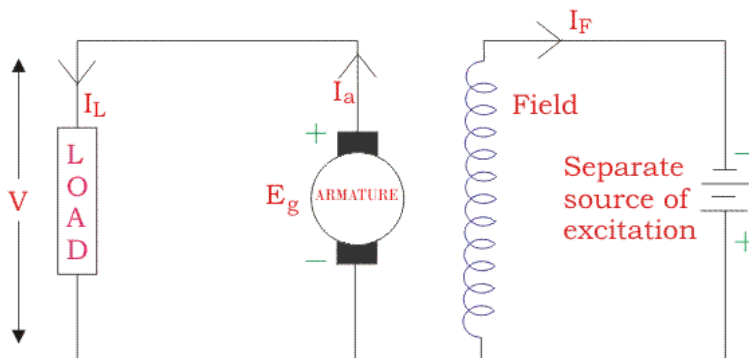

Separately Excited DC Generator

Voltage drop in the armature = $I_a \times R_a$ (R_a is the armature resistance) Let, $I_a = I_L = I$ (say) Then, voltage across the load, $V = IR_a$ Power generated, $P_g = E_g \times I$ Power delivered to the external load, $P_L = V \times I$.

Self-excited DC Generators

These are the generators whose field magnets are energized by the current supplied by themselves. In these type of machines field coils are internally connected with the armature. Due to residual magnetism some flux is always present in the poles. When the armature is rotated some emf is induced. Hence some induced current is produced. This small current flows through the field coil as well as the load and thereby strengthening the pole flux. As the pole flux strengthened, it will produce more armature emf, which cause further increase of current through the field. This increased field current further raises armature emf and this cumulative phenomenon continues until the excitation reaches to the rated value. According to the position of the field coils the Self-excited DC generators may be classified as...

1. Series wound generators
2. Shunt wound generators
3. Compound wound generators

Series Wound Generator

In these type of generators, the field windings are connected in series with armature conductors as shown in figure below. So, whole current flows through the field coils as well as the load. As series field winding carries full load current it is designed with relatively few turns of thick wire. The electrical resistance of series field winding is therefore very low (nearly 0.5Ω). Let, R_{SC} = Series winding resistance I_{SC} = Current flowing through the series field R_a = Armature resistance

I_a = Armature current I_L = Load current V = Terminal voltage E_g = Generated emf

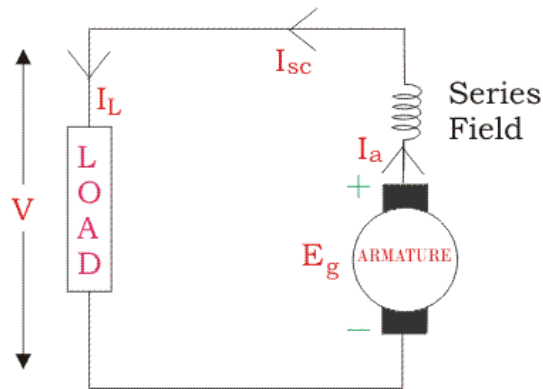

Series Wound Generator

Then, $I_a = I_{sc} = I_L = I$ (say) Voltage across the load, $V = E_g - I(I_a \times R_a)$ Power generated, $P_g = E_g \times I$
 Power delivered to the load, $P_L = V \times I$

Shunt Wound DC Generators

In these type of DC generators the field windings are connected in parallel with armature conductors as shown in figure below. In shunt wound generators the voltage in the field winding is same as the voltage across the terminal. Let, R_{sh} = Shunt winding resistance I_{sh} = Current flowing through the shunt field R_a = Armature resistance I_a = Armature current I_L = Load current V = Terminal voltage E_g = Generated emf

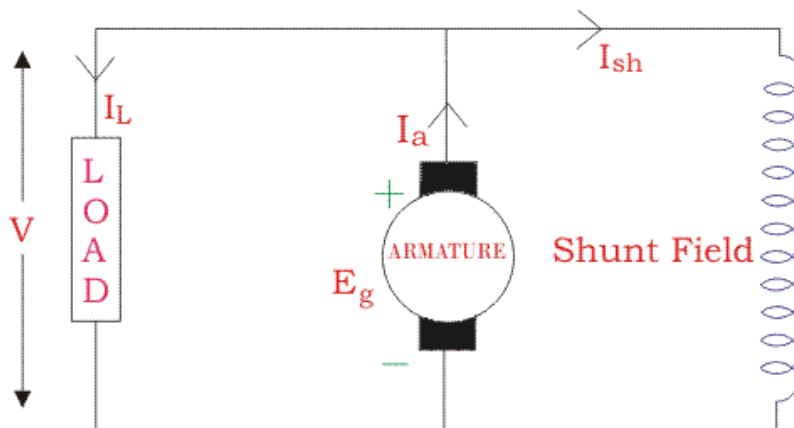

Shunt Wound Generator

Here armature current I_a is dividing in two parts, one is shunt field current I_{sh} and another is load current I_L . So, $I_a = I_{sh} + I_L$ The effective power across the load will be maximum when I_L will be maximum. So, it is required to keep shunt field current as small as possible. For this purpose the

resistance of the shunt field winding generally kept high (100 Ω) and large no of turns are used for the desired emf. Shunt field current, $I_{sh} = V/R_{sh}$ Voltage across the load, $V = E_g - I_a R_a$ Power generated, $P_g = E_g \times I_a$ Power delivered to the load, $P_L = V \times I_L$

Compound Wound DC Generator

In series wound generators, the output voltage is directly proportional with load current. In shunt wound generators, output voltage is inversely proportional with load current. A combination of these two types of generators can overcome the disadvantages of both. This combination of windings is called compound wound DC generator. Compound wound generators have both series field winding and shunt field winding. One winding is placed in series with the armature and the other is placed in parallel with the armature. This type of DC generators may be of two types- short shunt compound wound generator and long shunt compound wound generator.

Short Shunt Compound Wound DC Generator

The generators in which only shunt field winding is in parallel with the armature winding as shown in figure.

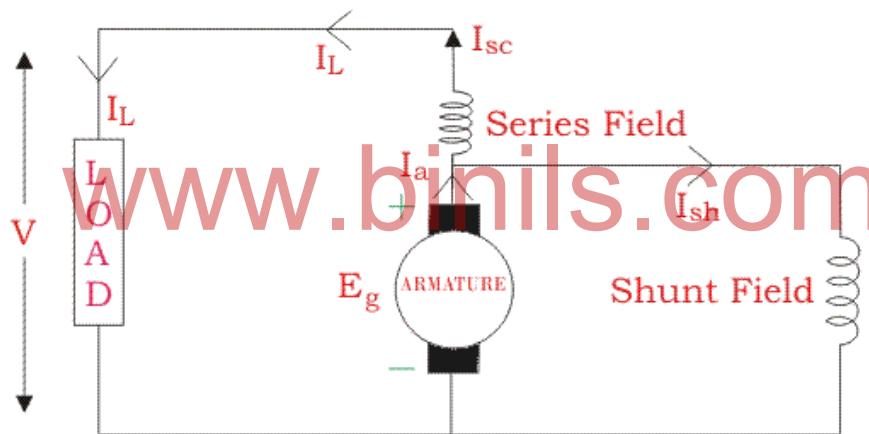

Short Shunt Compound Wound Generator

Series field current, $I_{sc} = I_L$ Shunt field current, $I_{sh} = (V + I_{sc} R_{sc}) / R_{sh}$ Armature current, $I_a = I_{sh} + I_L$ Voltage across the load, $V = E_g - I_a R_a - I_{sc} R_{sc}$ Power generated, $P_g = E_g \times I_a$ Power delivered to the load, $P_L = V \times I_L$

Long Shunt Compound Wound DC Generator

The generators in which shunt field winding is in parallel with both series field and armature winding as shown in figure.

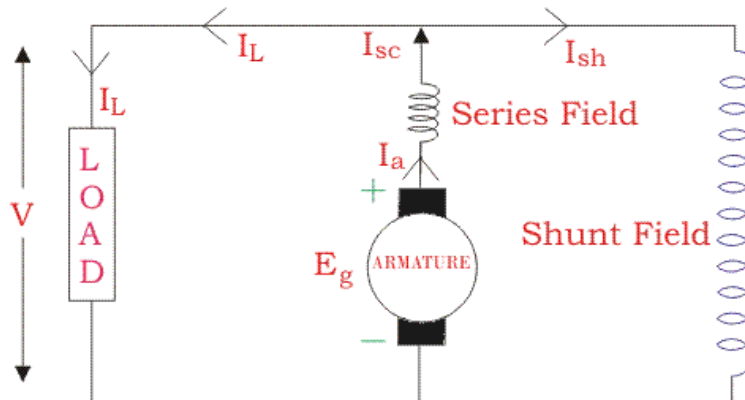

Long Shunt Compound Wound Generator

Shunt field current, $I_{sh} = V/R_{sh}$ Armature current, $I_a =$ series field current, $I_{sc} = I_L + I_{sh}$ Voltage

across the load, $V = E_g - I_a R_a - I_{sc} R_{sc} = E_g - I_a (R_a + R_{sc})$ [$\therefore I_a = I_{cs}$] Power generated, $P_g = E_g \times I_a$

Power delivered to the load, $P_L = V \times I_L$ In a compound wound generator, the shunt field is stronger than the series field. When the series field assists the shunt field, generator is said to be cumulatively compound wound. On the other hand if series field opposes the shunt field, the generator is said to be differentially compound wound.

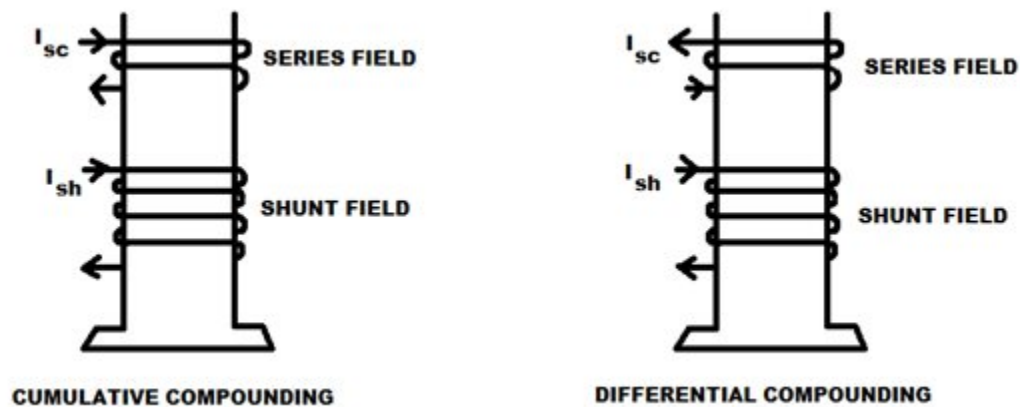

Separately Excited DC Generators

- Separately excited DC Generators are used in laboratories for testing as they have a wide range of voltage output.
- Used as a supply source of DC motors.

Shunt wound Generators

- DC shunt wound generators are used for lighting purposes.
- Used to charge the battery.

- Providing excitation to the alternators.

Series Wound Generators

- DC series wound generators are used in DC locomotives for regenerative braking for providing field excitation current.
- Used as a booster in distribution networks.
- Over compounded cumulative generators are used in lighting and heavy power supply.
- Flat compounded generators are used in offices, hotels, homes, schools, etc.
- Differentially compounded generators are mainly used for arc welding purpose.

DC MOTORS

A DC motor like we all know is a device that deals in the conversion of electrical energy to mechanical energy and this is essentially brought about by two major parts required for the **construction of DC motor**, namely.

1. Stator – The static part that houses the field windings and receives the supply and,
2. Rotor – The rotating part that brings about the mechanical rotations.

Other than that there are several subsidiary parts namely the

1. Yoke of DC motor.
2. Poles of DC motor.
3. Field winding of DC motor.
4. Armature winding of DC motor.
5. Commutator of DC motor.
6. Brushes of DC motor.

www.binils.com

All these parts put together configures the total **construction of a DC motor**. Now let's do a detailed discussion about all the essential parts of DC motor.

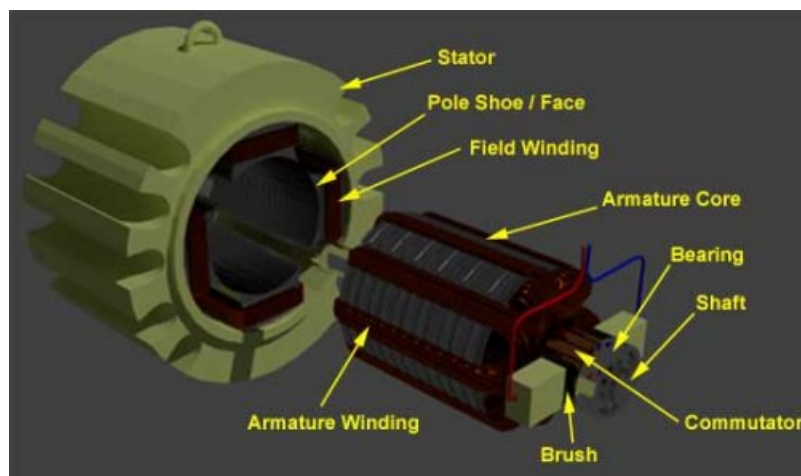

Yoke of DC Motor



The magnetic frame or the **yoke of DC motor** made up of cast iron or steel and forms an integral part of the stator or the static part of the motor. Its main function is to form a protective covering over the inner sophisticated parts of the motor and provide support to the armature. It also supports the field system by housing the magnetic poles and field winding of the dc motor.

Armature Winding of DC Motor

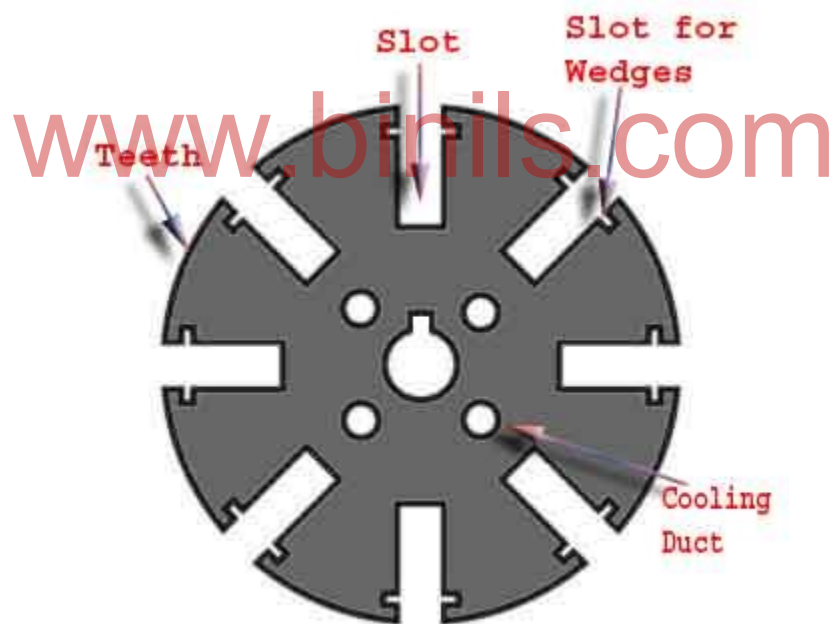

The **armature winding of DC motor** is attached to the rotor, or the rotating part of the machine, and as a result is subjected to altering **magnetic field** in the path of its rotation which directly results in magnetic losses. For this reason the rotor is made of armature core, that's made with several low-hysteresis silicon steel lamination, to reduce the magnetic losses like hysteresis and **eddy current** loss respectively. These laminated steel sheets are stacked together to form the cylindrical structure of the armature core.

The armature core are provided with slots made of the same material as the core to which the armature winding made with several turns of copper wire distributed uniformly over the entire periphery of the core. The slot openings a shut with fibrous wedges to prevent the conductor from plying out due to the high centrifugal force produced during the rotation of the armature, in

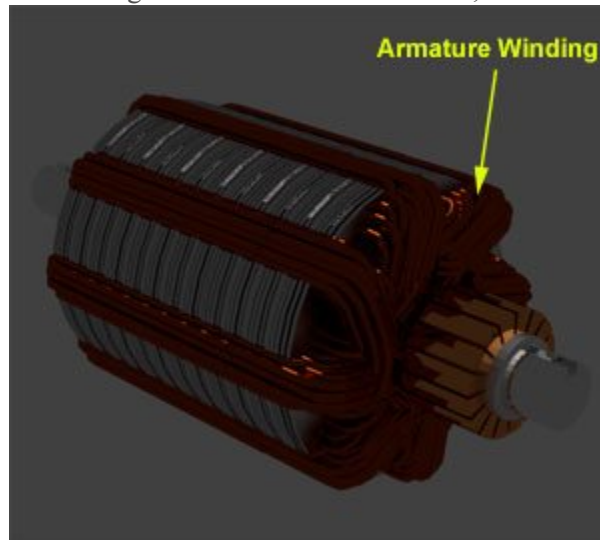

presence of supply current and field. The construction of **armature winding of DC motor** can be of two types:-

Lap Winding

In this case the number of parallel paths between conductors A is equal to the number of poles P . i.e $A = P$ ***An easy way of remembering it is by remembering the word LAP-----> $LA=P$

Wave Winding

Here in this case, the number of parallel paths between conductors A is always equal to 2 irrespective of the number of poles. Hence the machine designs are made accordingly.

Commutator of DC Motor

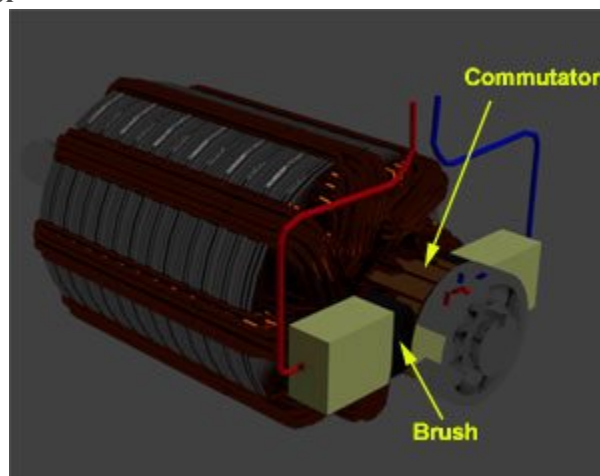

The **commutator of DC motor** is a cylindrical structure made up of copper segments stacked together, but insulated from each other by mica. Its main function as far as the DC motor is concerned is to commute or relay the supply **current** from the mains to the armature winding housed over a rotating structure through the **brushes of DC motor**.

Brushes of DC Motor

The **brushes of DC motor** are made with carbon or graphite structures, making sliding contact over the rotating commutator. The brushes are used to relay the current from external circuit to the rotating commutator from where it flows into the armature winding. So, the commutator and brush unit of the DC motor is concerned with transmitting the power from the static **electrical circuit** to the mechanically rotating region or the rotor.

PRINCIPLE OF OPERATION

A **DC motor** in simple words is a device that converts direct current (electrical energy) into mechanical energy. It's of vital importance for the industry today, and is equally important for engineers to look into the **working principle of DC motor** in details that has been discussed in this article. In order to understand the **operating principle of DC motor** we need to first look into its

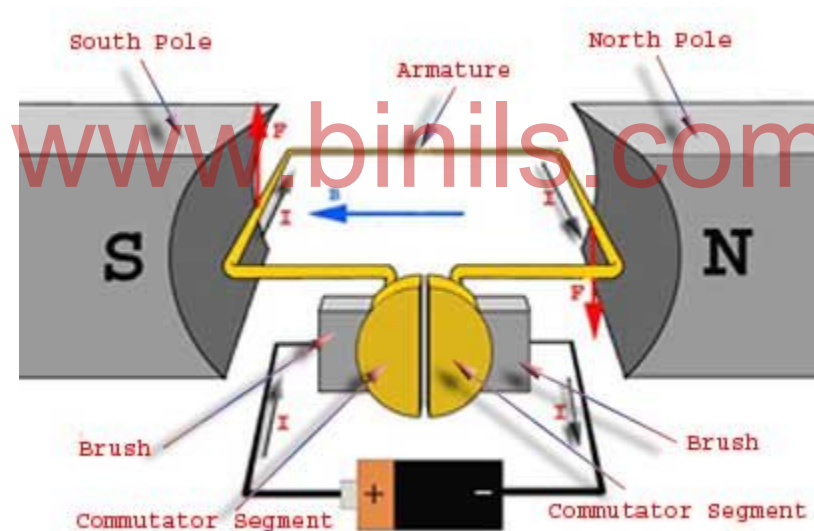

constructional feature. The very basic **construction** of a DC motor contains a **current** carrying armature which is connected to the supply end through commutator segments and brushes it is placed within the north south poles of a permanent or an electro-magnet as shown in the diagram below.

Now to go into the details of the **operating principle of DC motor** its important that we have a clear understanding of Fleming's left hand rule to determine the direction of force acting on the armature conductors of DC motor.

Fleming's left hand rule says that if we extend the index finger, middle finger and thumb of our left hand in such a way that the current carrying conductor is placed in a magnetic field (represented by the index finger) is perpendicular to the direction of current (represented by the middle finger), then the conductor

experiences a force in the direction (represented by the thumb) mutually perpendicular to both the direction of field and the current in the conductor.

Starters of DC Motors:

Necessity of a starter:

The voltage equation of a DC motor is,

$$V = E_b + I_a R_a$$

Where,

V → Supply voltage

E_b → Back emf

I_a → armature current

R_a → armature resistance

$$I_a = \frac{V - E_b}{R_a}$$

At the instant of starting

$E_b = 0$ because at that time

$N = 0$ (since $E_b \propto N$)

Therefore the armature current

$$I_a = \frac{V - 0}{R_a} = \frac{V}{R_a}$$

Normally the armature circuit resistance is always less than 1Ω .

At starting the motor takes large amount of current which is nearly 25 times the full load current. This large amount of current cannot be allowed to flow in a motor even for a short period. This excessive current has to be prevented because,

1. It would cause heavy sparking at the brushes which may destroy the commutator and brush gear.
2. It causes sudden depression of voltage of supply (large voltage drop) system causing disturbances to other loads connected in the system.

To avoid this a resistance is introduced in series with the armature (for the duration of starting period only), which limits the starting current to a safe value.

The starting resistance is gradually cut out as the motor gains speed and develops the back emf, which then regulates the speed of the motor.

Types of DC motor starters

Three point starters

Four point starters

Three point starter

The connection diagram of a three point starter is shown in the figure

When the handle is moved to on position the soft iron, which is attached to the handle, is attracted by the electromagnet. When the handle is in on position, the motor achieves its rated full speed, which develops back emf. This back emf then regulates the armature current.

- The starting resistance is connected in series with the armature of a DC motor.
- A handle, which can be moved over the starting resistance against the spring.

- A no-voltage release (NVR) coil is connected in series with the field winding.
- An OLR (Over Load Release) coil is connected in series with the armature.
- A movable arm is placed near the OLR coil.

Operation:

The handle is moved over the starting resistance after switching on the supply. When the handle is at stud no1, the full starting resistance is included in series with the armature. Therefore the starting current is reduced. When the handle is further moved the resistances are cut out gradually. At the same time the motor develops back emf when it gathers speed.

Protective Devices:

Two protective devices are incorporated in the starter. They give the necessary protection to the motor from from overload and power supply failure.

i. NVR (No Voltage Release):

The NVR is an electromagnet. The coil is connected in series with field winding. When the handle is in on position, the no volt coil is magnetized and attracts the soft iron and keeps the handle is in on position against the spring tension. In the case of failure or disconnection of the supply or a break in the field circuit, the NVR coil is de-energized thereby releasing the arm, which is pulled back by the spring to the off position.

ii. OLR (Over Load Release):

The over current release consists of an electromagnet connected in the supply line. If the motor becomes over loaded beyond a certain predetermined value, the line current (or) armature current increases and hence the attracting power of electro magnet increases. Then the movable arm is lifted and short circuits the electromagnet (NVR). Hence the arm is released and return to off position.

Demerits of 3- point starter

The motor speed can be increased by weakening the flux [$N^{-1/4}$], while employing this method, to decrease the flux, the field current is to be decreased to achieve speeds above the rated speed. To achieve higher speeds, the field current is to be reduced to a very low value. This low value of current also passes through NVR, which is unable to create enough electromagnetic pull to overcome the spring tension. This is an undesirable feature of 3-point starter which makes it unsuitable for variable speed motors.

Dc compound motor:

A DC compound motor consists of both series and shunt field windings.

The DC compound motor is further classified into two types. They are,

- (a) Long shunt compound motor
- (b) Short shunt compound motor

(a) Long shunt compound motor

In this motor the shunt field winding is connected across both armature and series field winding figure(d) shows connection diagram of a long shunt compound motor.

From this diagram,

$$I_l = I_{se} + I_{sh}$$

$$I_{se} = I_a$$

$$I_l = I_a + I_{sh}$$

$$I_{sh} = \frac{V}{R_{sh}}$$

The voltage equation of this motor is given by,

$$V = E_b + I_a R_a + I_{se} R_{se} + V_{brush}$$

Where $I_a = I_{se}$

$$V = E_b + I_a (R_a + R_{se}) + V_{brush}$$

www.binils.com

(b) Short shunt compound motor

In this type of motor the shunt field winding is across the armature and series field winding is connected in series with this combination. The figure (2) shows connection diagram of a short shunt compound motor.

$$I_l = I_{se}, \quad I_l = I_a + I_{sh}$$

$$I_l = I_{se} = I_a + I_{sh}$$

The voltage across the shunt field winding can be found out from the voltage equation.

$$V = E_b + I_a R_a + I_{se} R_{se} + V_{brush}$$

$$I_{se} = I_l$$

$$V = E_b + I_a R_a + I_{se} R_{se} + V_{brush}$$

Voltage drop across the shunt field winding is,

$$V - I_l R_{se}$$

$$V_{sh} = E_b + I_a R_a + V_{brush}$$

$$I_{sh} = \frac{V - I_a R_{se}}{R_{sh}}$$

The compound motors again can be classified into two types

- i) Cumulative compound motor
- ii) Differential compound motor

Cumulative compound motor

In this type of motor the two field winding fluxes aid each other i.e., flux due to the series field winding strengthens the flux due to the shunt field winding. The winding connection diagram is shown in the figure (f)

Differential compound motor:

In this type of motor the two field winding fluxes opposes each other i.e., flux due to series field winding weakens the field due to shunt field winding figure(g). shows winding connection diagram of this motor.

Applications of Dc motor

Shunt motor:

Dc shunt motors are used where the speed has to remain nearly constant with load and where a high starting torque is not required. Thus shunt motors may be used for driving centrifugal pumps and light machine tools, wood working machines, lathe etc.,

Series motor:

Series motors are used where the load is directly attached to the shaft or through a gear arrangement and where there is no danger of the load being “ thrown off”. Series motors are ideal for use in electric trains, where the self-weight of the train acts as load and for cranes, hoists, fans, blowers, conveyers, lifts etc. where the starting torque requirement is high.

Compound motor:

Compound motors are used for driving heavy machine tools for intermittent loads shears, punching machines etc.,

4 POINT STARTER

A **4 Point Starter** is almost similar in functional characteristics like **3 Point Starter**. In the absence of back EMF, the 4 Point Starter acts as a limiting current device while starting of the DC motor. 4 Point Starter also acts a **protecting device**.

The basic **difference** in 4 Point Starter as compared to 3 Point Starter is that in this a holding coil is removed from the shunt field circuit. This coil after removing is connected across the line in series with a current limiting resistance R. The **studs** are the contact points of the resistance represented by 1, 2, 3, 4, 5 in the figure below.

The **schematic connection diagram** of a 4 Point Starter is shown below.

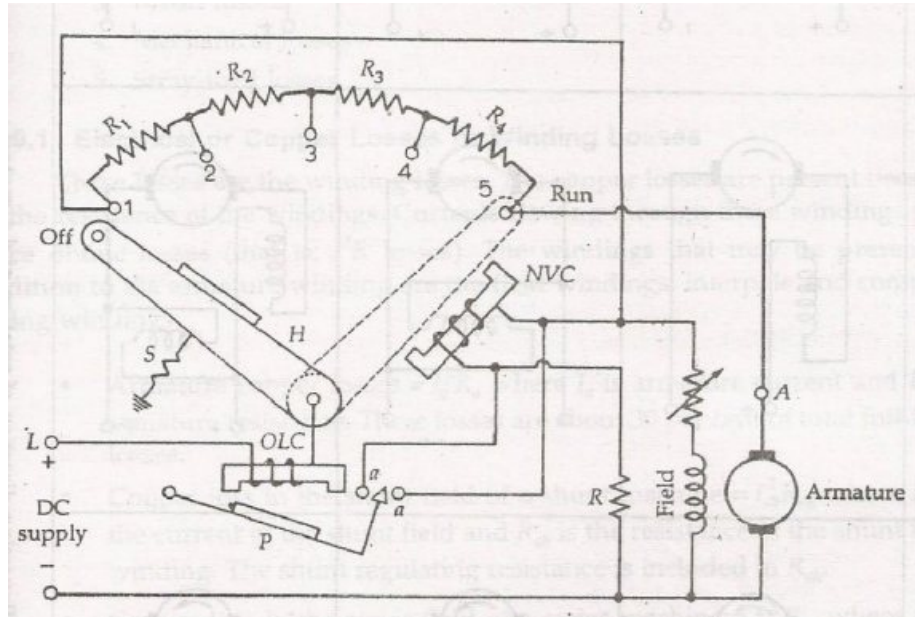

The above arrangement forms three parallel circuits. They are as follows:-

- Armature, starting resistance and the shunt field winding.
- A variable resistance and the shunt field winding.
- Holding coil and the current limiting resistance.

With the above three arrangements of the circuit, there will be no effect in the current through the holding coil if there is any variation in speed of the motor or any change in field current of the motor. This is because the two circuits are independent of each other.

The only **limitation** or the drawback of the 4 point starter is that it cannot limit or control the high current speed of the motor. If the field winding of the motor gets opened under running condition, the field current automatically reduces to zero. But as some of the residual flux is still present in the motor, and we know that the flux is directly proportional to the speed of the motor. Therefore, the speed of the motor increases drastically, which is dangerous and thus protection is not possible. This sudden increase in the speed of the motor is known as **High-Speed Action of the Motor**.

Now a days automatic push button starters are also used. In the automatic starters, the **ON** push button is pressed to connect the current limiting starting resistors in series with the armature circuit. As soon as the full line voltage is available to the armature circuit, this resistor is gradually disconnected by an automatic controlling arrangement.

3 POINT STARTER

3 Point Starter is a device whose main function is starting and maintaining the speed of the DC shunt motor. Mainly there are three main points or terminals in 3 point starter of DC motor. They are as follows

- L is known as Line terminal, which is connected to the positive supply.
- A is known as the armature terminal and is connected to the armature windings.
- F is known as the field terminal and is connected to the field terminal windings.

It consists of a graded resistance R to limit the starting current. The handle H is kept in the **OFF** position by a spring S. The handle H is manually moved, for starting the motor and when it makes contact with resistance stud 1 the motor is said to be in the **START** position. In this initial start position, the field winding of the motor receives the full supply voltage, and the armature current is limited to a certain safe value by the resistance ($R = R_1 + R_2 + R_3 + R_4$).

Working of 3 Point Starter

The starter handle is now moved from stud to stud, and this builds up the speed of the motor until it reaches the **RUN** position. The Studs are the contact point of the resistance. In the RUN position, three main points are considered. They are as follows.

- The motor attains the full speed.
- The supply is direct across both the windings of the motor.
- The resistance R is completely cut out.

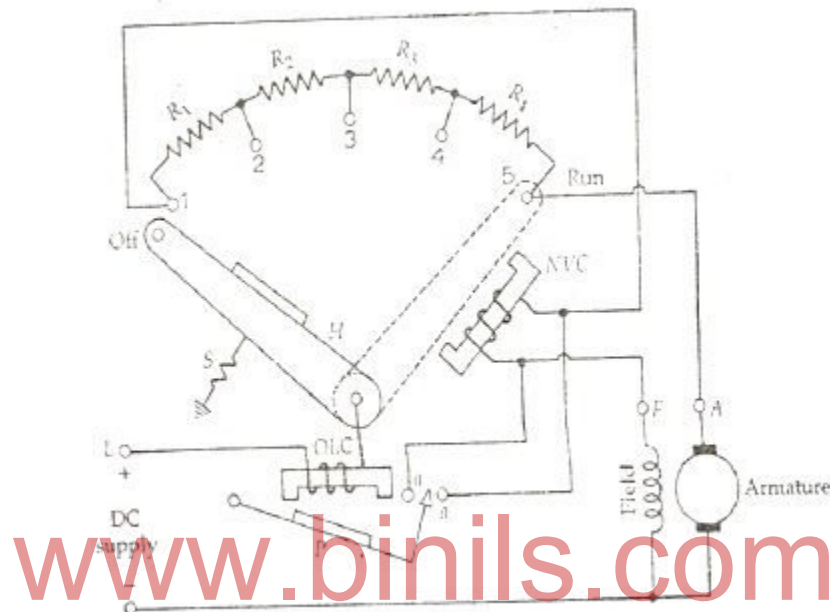

The handle H is held in RUN position by an electromagnet energized by a **no volt trip coil (NVC)**. This no volt trip coil is connected in series with the field winding of the motor. In the event of switching OFF, or when the supply voltage falls below a predetermined value, or the complete failure of supply while the motor is running, NVC is energized. The handle is released and pulled back to the OFF position by the action of the spring. The current to the motor is cut off, and the motor is not restarted without a resistance R in the armature circuit. The no voltage coil also provides protection against an open circuit in the field windings.

The No Voltage Coil (NVC) is called **NO-VOLT** or **UNDERVOLTAGE** protection of the motor. Without this protection, the supply voltage might be restored with the handle in the RUN position. The full line voltage is directly applied to the armature. As a result, a large amount of current is generated.

The other protective device incorporated in the starter is the overload protection. The **Over Load Trip Coil (OLC)** and the **No Voltage Coil (NVC)** provide the overload protection of the motor. The overload coil is made up of a small electromagnet, which carries the armature current. The magnetic pull of the Overload trip coil is insufficient to attract the strip P, for the normal values of the armature current

When the motor is overloaded, that is the armature current exceeds the normal rated value, P is attracted by the electromagnet of the OLC and closes the contact aa thus, the No Voltage Coil is short-circuited, shown in the figure of 3 Point Starter. As a result, the handle H is released, which returns to the OFF position and the motor supply is cut off.

To stop the motor, the starter handle should never be pulled back as this would result in burning the starter contacts. Thus, to stop the motor, the main switch of the motor should be opened.

Drawbacks of a 3 Point Starter

The following drawbacks of a 3 point starter are as follows:-

- The 3 point starter suffers from a serious drawback for motors with a large variation of speed by adjustment of the field rheostat.
- To increase the speed of the motor, the field resistance should be increased. Therefore, the current through the shunt field is reduced.
- The field current may become very low because of the addition of high resistance to obtain a high speed.
- A very low field current will make the holding electromagnet too weak to overcome the force exerted by the spring.
- The holding magnet may release the arm of the starter during the normal operation of the motor and thus, disconnect the motor from the line. This is not a desirable action.

Hence, to overcome this difficulty the 4 Point Starter is used.

Necessity of Starters for DC Motors

The armature current of a motor is given by

$$I_a = \frac{V - E}{R_a} \dots \dots \dots (1)$$

Thus, I_a depends upon E and R_a , if V is kept constant. When the motor is first switched ON, the armature is stationary. Hence, the back EMF E_b is also zero. The initial starting armature current I_{as} is given by the equation shown below.

$$I_{as} = \frac{V - 0}{R_a} = \frac{V}{R_a} \dots \dots \dots (2)$$

Since, the armature resistance of a motor is very small, generally less than one ohm. Therefore, the starting armature current I_{as} would be very large. **For example** – if a motor with the armature resistance of 0.5 ohms is connected directly to a 230 V supply, then by putting the values in the equation (2) we will get.

$$I_{as} = \frac{V}{R_a} = \frac{230}{0.5} = 460 \quad \text{Ampere}$$

This large current would damage the brushes, commutator and windings.

As the motor speed increases, the back EMF increases and the difference $(V - E)$ go on decreasing. This results in a gradual decrease of armature current until the motor attains its stable speed and the corresponding back EMF. Under this condition, the armature current reaches its desired value. Thus, it is found that the back EMF helps the armature resistance in limiting the current through the armature.

Since at the time of starting the DC Motor, the starting current is very large. At the time of starting of all DC Motors, except for very small motors, an extra resistance must be connected in series with the armature. This extra resistance is added so that a safe value of the motor is maintained and to limit the starting current until the motor has attained its stable speed.

The series resistance is divided into sections which are cut out one by one, as the speed of the motor rises and the back EMF builds up. The extra resistance is cut out when the speed of the motor builds up to its normal value.

REVIEW QUESTIONS

PART-A

1. What is a node?
2. Write the expression for emf equation of a transformer.
3. State the different types of DC generator.
4. Mention the two types of windings in armature.
5. Name the two types of induced emf.
6. What is eddy current?
7. Draw the diagram of DC shunt generator.
8. List the two field windings in a compound generator
9. Distinguish the usage of shunt and separately excited systems.
10. What is the need for having brush contacts in DC machines?
11. State the reason for having high current through the armature during starting.

PART-B

12. What is the working principle of a dc motor?
13. State Ohm's law
14. A voltage wave is represented by $v = 200 \sin 314t$, find the RMS and Average value of the wave.
15. State Kirchoff's laws
16. Explain the construction and working principle of dc motor.
17. Why dc series motors to be started with load?
18. Why starter is needed for starting a motor?
19. What are the different types of starters that are used for a dc motor?
20. Why core loss is said to be a constant loss?

21. Write the different types of dc motors and give their applications?
22. With a neat diagram describe the construction and working principle of a dc motor.
23. List the applications of DC motors.
24. Explain the phenomenon of back emf in DC motor
25. Distinguish between shunt and series field coil construction in DC machine?

PART-C

26. Explain the construction and working principle of a DC generator with neat diagrams.
27. Explain with circuit diagrams to classify the DC motors. Draw the Characteristics of these motors
28. An electrical appliance consumes 1.2 kWh in 30 minutes at 120 V. What is the current drawn by the appliance?
29. Write the equation for converting a Delta connected network to equivalent star connected network and vice versa.
30. A $10\ \Omega$ resistor is in series with a parallel combination of two resistors of $15\ \Omega$ and $5\ \Omega$. If the constant current in the $5\ \Omega$ resistor is 6 amperes, what total power is dissipated in the three resistors. 2. A total voltage of 5 volts drops across two resistors in series. If the resistor values are $R_1 = 10\ \Omega$ and $R_2 = 40\ \Omega$, determine the voltage drop across each resistor.
31. Three $90\ \Omega$ resistors are connected in a delta connection. Determine wye equivalent.
32. What are the various parts of a DC machine?

www.binils.com

UNIT II

AC CIRCUITS AND AC MACHINES

2.1 FUNDAMENTALS OF AC VOLTAGE, CURRENT

- An alternating voltage is any voltage that varies both in magnitude and polarity with respect to time. Similarly, an alternating current is any current that varies in both magnitude and direction with respect to time.

- The reversal polarity of voltage or direction of current occurs at regular intervals of time. The circuits in which alternating currents flow are called alternating current (A.C) circuits.

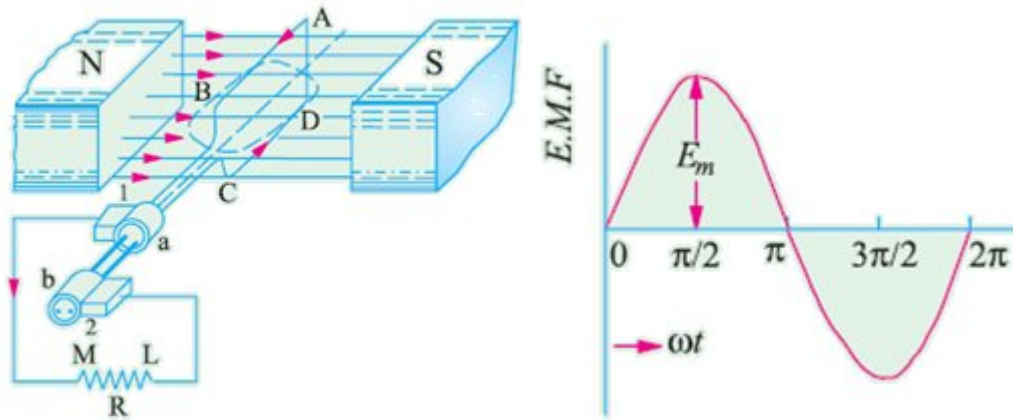

Figure 2.1.

- Alternating voltage can be generated by rotating a coil in a magnetic field as shown in fig. the value of voltage generated depends on the number of turns in the coil, field strength and the speed at which the coil rotates.

Sinusoidal alternating voltage, $e = E_m \sin \omega t$ volts.

Where e = instantaneous value of alternating voltage,

E_m = maximum value of alternating voltage

ω = angular velocity of the coil.

2.1.1. PEAK VALUE (OR) MAXIMUM VALUE

This is the maximum value of the alternating quantity attained by it in a cycle. It is the highest of the instantaneous values. Maximum value is called the peak value, crest value, or the amplitude. Thus I_m denotes maximum current and E_m denotes the maximum voltage.

2.1.2. AVERAGE OR MEAN VALUE

- The average or mean of an alternating quantity over a given interval is the sum of all instantaneous values divided by the number of values taken over that interval.
- If the alternating quantity is represented by a curve, the average value is the average height of the curve.

- The average height of any curve is found by dividing the area under the curve by the length of the base or the interval of the curve over which the curve extends.

$$\text{Average value} = \frac{\text{Area under the curve}}{\text{Length of base of the curve}}$$

2.1.3. ROOT MEAN SQUARE VALUE OF SINE WAVE (RMS)

- When an alternating current flows through a resistance for a certain time, certain amount of heat is produced.
- Now assume that a direct current is passed through the same resistance for the same time such that the same amount of heat is developed.
- This value of steady current which has caused the same heat as that of alternating current is known as root mean square value or effective value.

2.1.4. FREQUENCY

The number of cycles completed in one second is called the frequency (f). The unit of frequency is Hertz (Hz).

$$1 \text{ Hertz} = 1 \text{ cycles per second}$$

$$1 \text{ Hz} = 1 \text{ c/s}$$

2.1.5. TIME PERIOD

The time required to complete one cycle is called the periodic time or simply the period (T).

The unit of time period is the second(s)

2.1.6. AMPLITUDE

The maximum positive or negative value of an alternating quantity is called amplitude.

2.1.7. POWER

- Power is defined as the rate of doing work, or the rate of change of energy. The voltage between any two points in an electric circuit is defined as the work done in moving unit positive charge from the point of lower potential to the point of higher potential.
- The energy required to transfer a charge of Q coulombs across a potential difference of V volts is given by

$$W = VQ$$

Power = Rate of change of Energy

$$P = \frac{\text{Energy}}{\text{Time}}$$

$$P = \frac{W}{t} \quad P = \frac{VQ}{t}$$

Since $I = \frac{Q}{t}$, $P = VI$

The unit of power is Watts (W).

2.1.8. POWER FACTOR

The ratio of active power (P) in watts to the apparent power (S) in volt amperes in an ac circuit is defined as the power factor of the circuit.

$$\text{Power factor} = \frac{\text{Active power}(VI \cos\theta)}{\text{Volt amperes}(VI)}$$

$$\text{Power factor} = \frac{P}{S}$$

$$P.F = \cos\theta$$

2.2. STAR AND DELTA CONNECTION

In a three phase system, there are three windings or phases. Each phase has two terminals ie, start and finish. The three windings are interconnected in two methods. They are

- (1) Star or Wye connection (Y)
- (2) Delta or Mesh connection (Δ)

2.2.1. STAR OR WYE CONNECTION (Y)

In this method similar ends of the three phases are joined together to form a common junction N. The junction N is called the star point or neutral point.

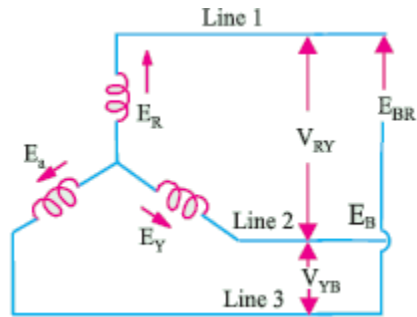

Figure 2.2.

2.2.2. DELTA OR MESH CONNECTION (Δ)

In this method of interconnection, the dissimilar ends of three phase windings are joined together i.e., finishing end of one phase is connected to the starting end of the other phase.

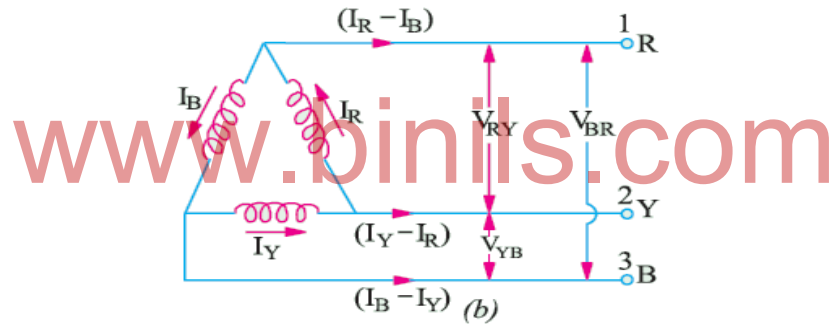

Figure 2.3.

2.2.3. RELATIONSHIP BETWEEN STAR AND DELTA CONNECTION PHASE VOLTAGE AND PHASE CURRENT

Star (Y) Connection	Delta (Δ) Connection
In STAR connection, the starting or finishing ends (Similar ends) of three coils are connected together to form the neutral point. A common wire is taken out from the neutral point which is	In DELTA connection, the opposite ends of three coils are connected together. In other words, the end of each coil is connected with the start of another coil, and three wires are taken out from

called Neutral.	the coil joints
There is a Neutral or Star Point	No Neutral Point in Delta Connection
Three phase four wire system is derived from Star Connections (3-Phase, 4 Wires System) We may Also derived 3 Phase 3 Wire System from Star Connection	Three phase three wire system is derived from Delta Connections (3-Phase, 3 Wires System)
Line Current is Equal to Phase Current. i.e. Line Current = Phase Current $I_L = I_{Ph}$	Line Voltage is Equal to Phase Voltage. i.e. Line Voltage = Phase Voltage $V_L = V_{Ph}$
Line Voltage is $\sqrt{3}$ times of Phase Voltage. i.e. $V_L = \sqrt{3} V_{Ph}$	Line Current is $\sqrt{3}$ times of Phase Current. i.e. $I_L = \sqrt{3} I_{Ph}$
The Total Power of three phases could be found by $P = \sqrt{3} \times V_L \times I_L \times \cos\Phi \dots \text{Or}$ $P = 3 \times V_{Ph} \times I_{Ph} \times \cos\Phi$	The Total Power of three phases could be found by $P = \sqrt{3} \times V_L \times I_L \times \cos\Phi \dots \text{or}$ $P = 3 \times V_{Ph} \times I_{Ph} \times \cos\Phi$

2.3. TRANSFORMER

- A transformer is a static device which transfers electric power from one circuit to another electric circuit without change of same frequency.

2.3.1. Principle of operation of Transformer

- The voltage can be raised or lowered in a circuit, but with a proportional increase or decrease in the current ratings. The main principle of operation of a transformer is mutual inductance between two circuits which is linked by a common magnetic flux.
- The principle of mutual inductance states that when two coils are inductively coupled and if current in one coil is changed uniformly then an e.m.f. gets induced in the other coil. This e.m.f. can drive a current, when a closed path is provided to it. The working principle of the transformer can be understood from the figure 2.4

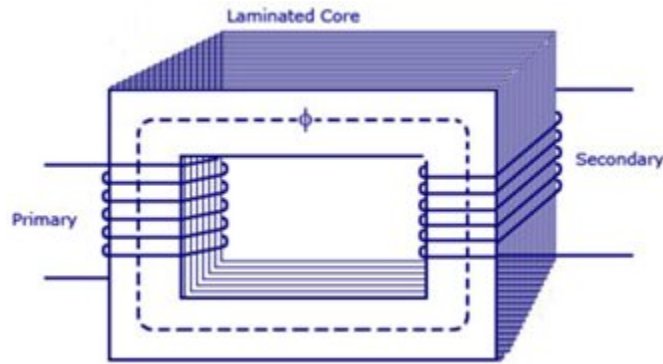

Figure 2.4. Transformer

- From Fig 2.4, the transformer has primary and secondary windings. The alternating current supply is given to the first coil and hence it can be called as the primary winding.
- The energy is drawn out from the second coil and thus can be called as the secondary winding.
- When primary winding is excited by an alternating voltage, it circulates an alternating current. This current produce an alternating flux (ϕ) which completes its path through common magnetic core as shown dotted in the fig 2.4.
- Thus an alternating, flux links with the secondary winding. As the flux is alternating, according to Faraday's law of an electromagnetic induction, mutually induced e.m.f. gets developed in the secondary winding.

According to Faraday's laws of Electromagnetic Induction as

$$Emf = M \frac{dI}{dt}$$

In short, a transformer carries the operations shown below:

- Transfer of electric power from one circuit to another.
- Transfer of electric power without any change in frequency.
- Transfer with the principle of electromagnetic induction.
- The two electrical circuits are linked by mutual induction.

2.3.2. TRANSFORMER CONSTRUCTION

- For the simple construction of a transformer, transformer has two coils and a laminated steel core. The two coils are insulated from each other and from the steel core.

- The device will also need some suitable container for the assembled core and windings, a medium with which the core and its windings from its container can be insulated.
- In all transformers that are used commercially, the core is made out of transformer sheet steel laminations assembled to provide a continuous magnetic path with minimum of air-gap included.
- The steel should have high permeability and low hysteresis loss. So, the steel should be made of high silicon content and must also be heat treated.
- By effectively **laminating the core**, the eddy-current losses can be reduced. The lamination can be done with the help of a light coat of core plate varnish on the surface.
- For a frequency of 50 Hertz, the thickness of the lamination varies from 0.35 mm to 0.5mm.

2.3.2.1. Construction of a Transformer

- The construction of a simple two-winding transformer consists of each winding being wound on a separate limb or core of the soft iron form which provides the necessary magnetic circuit.
- This magnetic circuit, know more commonly as the “transformer core” is designed to provide a path for the magnetic field to flow around, which is necessary for induction of the voltage between the two windings.

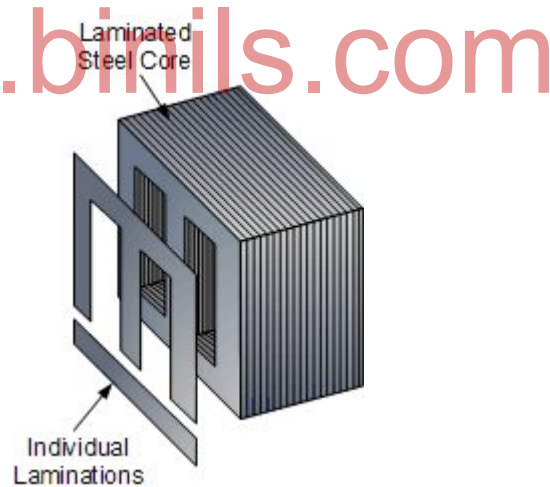

- However, this type of transformer construction where the two windings are wound on separate limbs is not very efficient since the primary and secondary windings are well separated from each other.

- This results in a low magnetic coupling between the two windings as well as large amounts of magnetic flux leakage from the transformer itself.
- But as well as this “O” shapes construction, there are different types of “transformer construction” and designs available which are used to overcome these inefficiencies producing a smaller more compact transformer.
- The efficiency of a simple transformer construction can be improved by bringing the two windings within close contact with each other thereby improving the magnetic coupling.
- Increasing and concentrating the magnetic circuit around the coils may improve the magnetic coupling between the two windings, but it also has the effect of increasing the magnetic losses of the transformer core.
- As well as providing a low reluctance path for the magnetic field, the core is designed to prevent circulating electric currents within the iron core itself. Circulating currents, called “eddy currents”, cause heating and energy losses within the core decreasing the transformers efficiency.
- These losses are due mainly to voltages induced in the iron circuit, which is constantly being subjected to the alternating magnetic fields setup by the external sinusoidal supply voltage.
- One way to reduce these unwanted power losses is to construct the transformer core from thin steel laminations.
- In all types of transformer construction, the central iron core is constructed from of a highly permeable material made from thin silicon steel laminations assembled together to provide the required magnetic path with the minimum of losses.
- The resistivity of the steel sheet itself is high reducing the eddy current losses by making the laminations very thin.
- These steel transformer laminations vary in thickness’s from between 0.25mm to 0.5mm and as steel is a conductor, the laminations are electrically insulated from each other by a very thin coating of insulating varnish or by the use of an oxide layer on the surface.

2.3.2.2. Transformer Core Construction

- Generally, the name associated with the construction of a transformer is dependant upon how the primary and secondary windings are wound around the central laminated steel core.
- The two most common and basic designs of transformer construction are the **Closed-core Transformer** and the **Shell-core Transformer**.
- In the “closed-core” type (core form) transformer, the primary and secondary windings are wound outside and surround the core ring.

- In the “shell type” (shell form) transformer, the primary and secondary windings pass inside the steel magnetic circuit (core) which forms a shell around the windings as shown below.

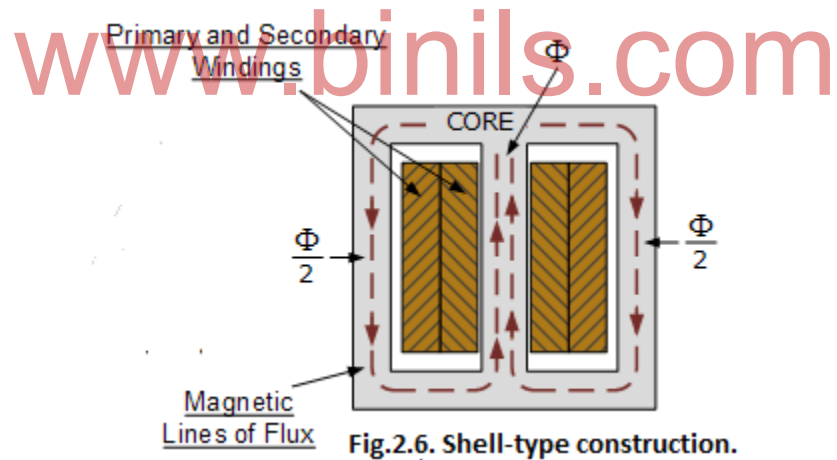
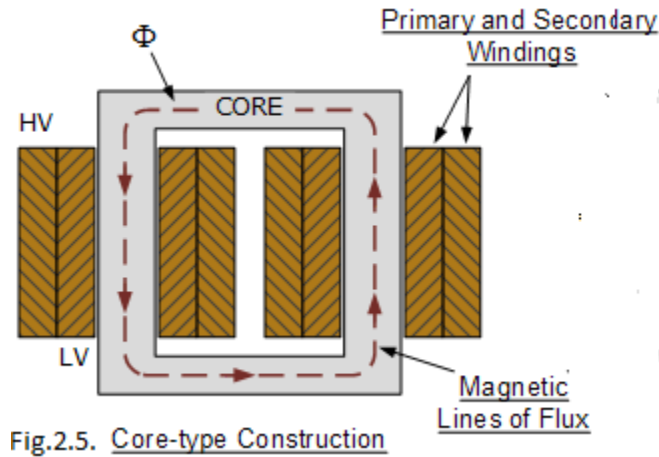

- In both types of transformer core design, the magnetic flux linking the primary and secondary windings travels entirely within the core with no loss of magnetic flux through air. In the core

type transformer construction, one half of each winding is wrapped around each leg (or limb) of the transformer's magnetic circuit as shown above.

- The coils are not arranged with the primary winding on one leg and the secondary on the other but instead half of the primary winding and half of the secondary winding are placed one over the other concentrically on each leg in order to increase magnetic coupling allowing practically all of the magnetic lines of force go through both the primary and secondary windings at the same time.
- However, with this type of transformer construction, a small percentage of the magnetic lines of force flow outside of the core, and this is called “leakage flux”.
- Shell type transformer cores overcome this leakage flux as both the primary and secondary windings are wound on the same centre leg or limb which has twice the cross-sectional area of the two outer limbs.
- The advantage here is that the magnetic flux has two closed magnetic paths to flow around external to the coils on both left and right hand sides before returning back to the central coils.
- This means that the magnetic flux circulating around the outer limbs of this type of transformer construction is equal to $\Phi/2$. As the magnetic flux has a closed path around the coils, this has the advantage of decreasing core losses and increasing overall efficiency.

2.3.2.3. Transformer Laminations

- The coils are firstly wound on a former which has a cylindrical, rectangular or oval type cross section to suit the construction of the laminated core.
- In both the shell and core type transformer constructions, in order to mount the coil windings, the individual laminations are stamped or punched out from larger steel sheets and formed into strips of thin steel resembling the letters “E’s”, “L’s”, “U’s” and “T’s” as shown below.

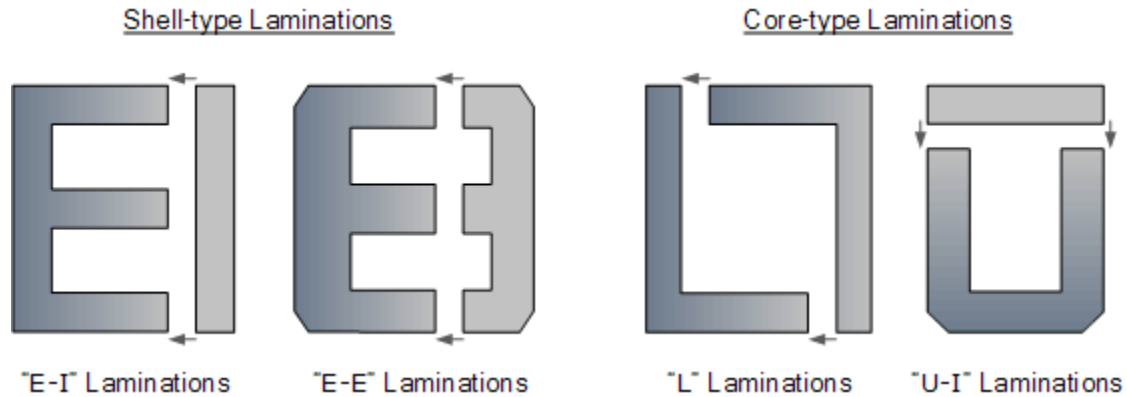

Fig 2.7

- These lamination stampings when connected together form the required core shape. For example, two “E” stampings plus two end closing “I” stampings to give an E-I core forming one element of a standard shell-type transformer core. These individual laminations are tightly butted together during the transformers construction to reduce the reluctance of the air gap at the joints producing a highly saturated magnetic flux density.
- Transformer core laminations are usually stacked alternately to each other to produce an overlapping joint with more lamination pairs being added to make up the correct core thickness. This alternate stacking of the laminations also gives the transformer the advantage of reduced flux leakage and iron losses.
- E-I core laminated transformer construction is mostly used in isolation transformers, step-up and step-down transformers as well as auto transformers.

2.3.2.4. Transformer Winding Arrangements

- Transformer windings form another important part of a transformer construction, because they are the main current-carrying conductors wound around the laminated sections of the core.

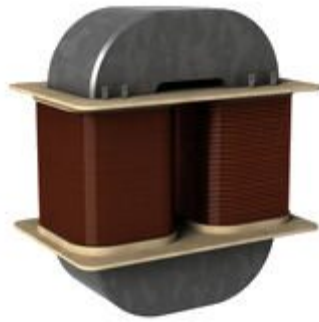

Fig 2.8

- In a single-phase two winding transformer, two windings would be present as shown. The one which is connected to the voltage source and creates the magnetic flux called the primary winding, and the second winding called the secondary in which a voltage is induced as a result of mutual induction.
- If the secondary output voltage is less than that of the primary input voltage the transformer is known as a “Step-down Transformer”. If the secondary output voltage is greater than the primary input voltage it is called a “Step-up Transformer”.

2.3.2.5. Core-type Construction

- The type of wire used as the main current carrying conductor in a transformer winding is either copper or aluminium. While aluminium wire is lighter and generally less expensive than copper wire, a larger cross sectional area of conductor must be used to carry the same amount of current as with copper so it is used mainly in larger power transformer applications.
- Small kVA power and voltage transformers used in low voltage electrical and electronic circuits tend to use copper conductors as these have a higher mechanical strength and smaller conductor size than equivalent aluminium types. The downside is that when complete with their core, these transformers are much heavier.
- Transformer windings and coils can be broadly classified into concentric coils and sandwiched coils. In core-type transformer construction, the windings are usually arranged concentrically around the core limb as shown above with the higher voltage primary winding being wound over the lower voltage secondary winding.



fig 2.9

- Sandwiched or “pancake” coils consist of flat conductors wound in a spiral form and are so named due to the arrangement of conductors into discs. Alternate discs are made to spiral from outside towards the centre in an interleaved arrangement with individual coils being stacked together and separated by insulating materials such as paper or plastic sheet. Sandwich coils and windings are more common with shell type core construction.
- **Helical Windings** also known as screw windings are another very common cylindrical coil arrangement used in low voltage high current transformer applications. The windings are made up of large cross sectional rectangular conductors wound on its side with the insulated strands wound in parallel continuously along the length of the cylinder, with suitable spacers inserted between adjacent turns or discs to minimize circulating currents between the parallel strands.
- The coil progresses outwards as a helix resembling that of a corkscrew. The insulation used to prevent the conductors shorting together in a transformer is usually a thin layer of varnish or enamel in air cooled transformers.
- This thin varnish or enamel paint is painted onto the wire before it is wound around the core. In larger power and distribution transformers the conductors are insulated from each other using oil impregnated paper or cloth. The whole core and windings is immersed and sealed in a protective tank containing transformer oil. The transformer oil acts as an insulator and also as a coolant.

Transformer mainly consists of

1. Magnetic circuit (consisting of core, limbs, yoke and damping structure.
2. Electrical circuit (consists of primary and secondary windings)
3. Dielectric circuit (consisting of insulations in different forms and used at the different places)
4. Tanks and accessories (conservator, breather, bushings, cooling tubes, etc.)

2.4. TYPES OF TRANSFORMER

The various types are described below

1. Position of the windings with respect to the core

- Core type
- Shell type

2. According to the transformation ratio or number of turns in the windings

- Step up
- Step down

3. Types of services

- Power transformer
- Distribution transformer
- Instrument transformer
 - Current transformer
 - Potential transformer
 - Auto transformer

4. On the basis of the supply

- Single phase
- Three phase

5. On the basis of cooling

- Air Natural (AN) or Self air cooled or dry type
- Air Forced (AF) or Air Blast type
- Oil Natural Air Natural (ONAN)
- Oil Natural Air Forced (ONAF)
- Oil Forced Air Forced (OFAF)
- Oil Natural Water Forced (ONWF)
- Oil Forced Water Forced (OFWF)

There are two basic parts of a transformer (i) magnetic core (ii) winding or coils.

- The core of the transformer is either square or rectangular in size. It is further divided into two parts. The vertical portion on which coils are wound is called **limb** while the top and bottom horizontal portion is called **yoke** of the core.
- Core is made up of laminations. Because of laminated type of construction, eddy current losses get minimized. Generally high grade silicon steel laminations (0.3 to 0.5mm thick)

are used. These laminations are insulated from each other by using insulation like varnish. For this generally 'L' shaped or 'T' shaped laminations are used.

The various construction used for the single phase transformers are Core type and Shell type.

2.4.1. Core Type Transformer

- It has a single magnetic circuit. The core is rectangular having two limbs. The windings encircle the core. The coils are used of cylindrical type. As mentioned earlier, the coils are wound in helical layers with different layers insulated from each other by paper or mica. Both the coils are placed on both the limbs.

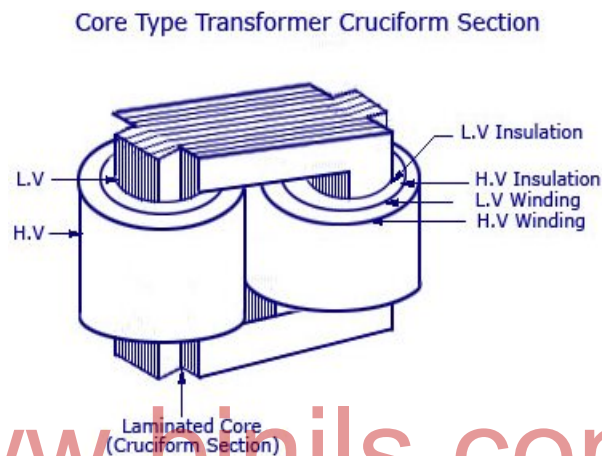

fig.2.10

- The low voltage coil is placed inside near the core while high voltage coil surrounds the low voltage coil. Core is made up of large number of thin laminations.
- As the windings are uniformly distributed over the two limbs, the natural cooling is more effective. The coils can be easily removed by removing the laminations of the top yoke, for maintenance.
- The fig (a) shows the schematic representation of the core type transformer while the fig(b) shows the view of actual construction of the core type transformer.

2.4.2. Shell Type Transformer

- It has double magnetic circuit. The core has three limbs. Both the windings are placed on the central limb.

- The core encircles most part of the windings. The coils used are generally multilayer disc type or sandwich coils.
- As mentioned earlier, each high voltage coil is between two low voltage coils and low voltage coils are nearest to top and bottom of the yokes.
- The core is laminated. While arranging the laminations of the core, the care is taken that all the joints at alternate layers are staggered. This is done to avoid narrow air gap at the joint, right through the cross-section of the core.

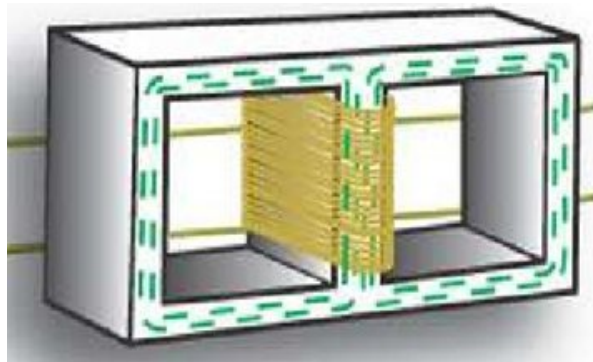

www.binils.com

fig 2.11

- Such joints are called over lapped or imbricated joints. Generally for very high voltage transformers, the shell type construction is preferred.
- As the windings are surrounded by the core, the natural cooling does not exist. For removing any winding for maintenance, large number of laminations are required to be removed.
- Fig(c) shows the schematic representation while the fig(d) shows the outaway view of the construction of the shell type transformer.

2.4.3. Advantages of shell type transformer

- Low leakage reactance.
- High mechanical strength.
- Low magnetising current.

2.4.4. Disadvantages

- Difficult to construct.
- Difficult to remove fault.

2.5. WINDINGS

- The coils used are wound on the limbs and are insulated from each other. Two windings are wound on two different limbs i.e., primary on one limb while secondary on other limb. But due to this leakage flux increases which affects the transformer performance badly.
- Similarly it is necessary that the windings should be very close to each other to have high mutual inductance.
- To achieve this, the two windings are split into number of coils and are wound adjacent to each other on the same limb.

Concentric windings is classified into four categories

1. Cylindrical winding
2. Helical winding
3. Disc winding
4. Sandwich winding

2.5.1. Cylindrical winding

- Cylindrical coils are used in the core type transformer. These coils are mechanically strong. These are wound in the helical layers.
- The different layers are insulated from each other by paper, cloth or mica. The low voltage winding is placed near the core from ease of insulating it from the core. The high voltage is placed after it. A very common arrangement is cylindrical concentric coils as shown in(a).

2.5.2. Sandwich winding

- A coil which is very commonly used for the shell type of transformer is sandwich coils. Each high voltage portion lies between the two low voltage portion sandwiching the high voltage portion.
- Such subdivision of windings into small portions reduces the leakage flux. Higher the degree of sub divisions, smaller is the reactance. The sandwich coil is shown in the fig(b). The top and bottom coils are low voltage coils. All the portions are insulated from each other by paper.

2.6. E.M.F. EQUATION OF A TRANSFORMER

- When the primary winding is excited by an alternating voltage V_1 , it circulates alternating current, producing an alternating flux ϕ . The primary winding has N_1 number of turns. The alternating flux ϕ linking with the primary winding itself induces an e.m.f. in it denoted as E_1 .

- The flux links with secondary winding through the common magnetic core. It produces induced e.m.f. E_2 in the secondary winding. This is mutually induced e.m.f. Let us derive the equations for E_1 and E_2 .
- The primary winding is excited by purely sinusoidal alternating voltage. Hence the flux produced is also sinusoidal in nature having maximum value of ϕ_m as shown in the figure.2.12.

The various quantities which affect the magnitude of the induced e.m.f. are:

From Faraday's law of electromagnetic induction the average e.m.f. induced in each turns is proportional to the average rate of change of flux.

Average e.m.f. per turn = Average rate of change of flux

$$\text{Average e.m.f. per turn} = \frac{d\phi}{dt}$$

Now, $\frac{d\phi}{dt}$ = Change in flux/Time required for change in flux

Consider the $1/4^{\text{th}}$ cycle of the flux as shown in figure. Complete cycle gets completed in $1/f$ seconds. In $1/4^{\text{th}}$ time period, the change in flux is from 0 to ϕ_m .

www.binils.com

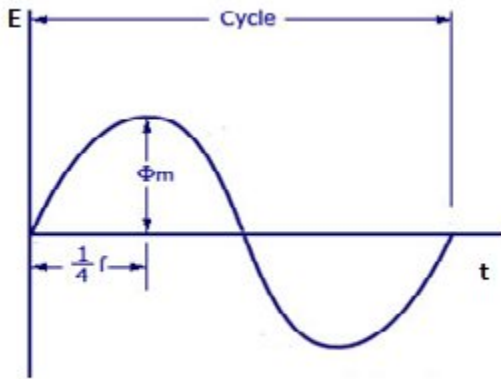

Fig.2.12.A.C. Wave form

Where,

Φ_m = Maximum value of flux

N_1 = Number of primary winding turns

N_2 = Number of secondary winding turns

f = Frequency of the supply voltage

E_1 = R.M.S. value of the primary induced e.m.f.

E_2 = R.M.S. value of secondary induced e.m.f.

$$\frac{d\Phi}{dt} = (\Phi_m - 0) \frac{1}{4f} \text{ as dt for } \frac{1}{4} \text{th time period is } \frac{1}{4f} \text{ seconds}$$

$$= 4f \Phi_m \text{ Wb/sec}$$

$$\text{Average e.m.f. per turn} = 4f \Phi_m \text{ volts}$$

As Φ is sinusoidal, the induced e.m.f. in each turn of both the windings is also sinusoidal in nature. For sinusoidal quantity, Form factor = R.M.S. value / Average value = 1.11

$$\text{R.M.S. value} = 1.11 \times \text{Average value}$$

R.M.S. value induced e.m.f. per turn = $1.11 \times 4f \phi_m = 4.44f \phi_m$

There are N_1 number of primary turns hence the R.M.S. value of induced e.m.f. of primary denoted as E_1 is,

$$E_1 = N_1 \times 4.44f \phi_m \text{ volts}$$

While as there are N_2 number of secondary turns hence the R.M.S. value of induced e.m.f. of secondary denoted as E_2 is, $E_2 = N_2 \times 4.44f \phi_m$ volts

The expressions of E_1 and E_2 are called e.m.f. equations of a transformer.

Thus e.m.f. equations are,

$$E_1 = N_1 \times 4.44f \phi_m \text{ volts}$$

$$E_2 = N_2 \times 4.44f \phi_m \text{ volts}$$

2.6.1. Voltage Ratio

We know from the e.m.f. equations of a transformer that

$$E_1 = N_1 \times 4.44f \phi_m \text{ volts and } E_2 = N_2 \times 4.44f \phi_m \text{ volts}$$

Taking ratio of the two equations we get,

$$\frac{E_2}{E_1} = \frac{N_2}{N_1} = K$$

1. If $N_2 > N_1$ i.e. $K > 1$, we get $E_2 > E_1$ then the transformer is called **step-up transformer**.
2. If $N_2 < N_1$ i.e. $K < 1$, we get $E_2 < E_1$ then the transformer is called **step-down transformer**.

2.6.2. Current Ratio

- For an ideal transformer there are no losses. Hence the product of primary voltage V_1 and primary current I_1 , is same as the product of secondary voltage V_2 and the secondary current I_2 .

So, $V_1 I_1 = \text{Input VA}$ and $V_2 I_2 = \text{Output VA}$

- For an ideal transformer, $V_1 I_1 = V_2 I_2$

$$\frac{V_2}{V_1} = \frac{I_1}{I_2} = K$$

2.7. LOSSES IN THE TRANSFORMER

1. Core or iron losses
 - Hysteresis loss

- Eddy current loss
2. Copper losses
 3. Stray losses

2.7.1. Iron Losses

Iron losses are caused by alternating flux in the core of the transformer as this loss occurs in the core it is also known as Core loss. Iron loss is further divided into hysteresis and eddy current loss.

2.7.1.1. Hysteresis Loss

- The core of the transformer is subjected to an alternating magnetizing force and for each cycle of emf, a hysteresis loop is traced out.
- Power is dissipated in the form of heat known as hysteresis loss and is given by the equation

$$P_h = K_\eta B_{\max}^{1.6} f V \text{ watts.}$$

Where

- K_η is a proportionality constant which depends upon the volume and quality of the material of the core used in the transformer.
- f is the supply frequency
- B_{\max} is the maximum or peak value of the flux density

The iron or core losses can be minimized by using silicon steel material for the construction of the core of the transformer.

2.7.1.2. Eddy Current Loss

- When the flux links with a closed circuit, an emf is induced in the circuit and the current flows, the value of the current depends upon the amount of emf around the circuit and the resistance of the circuit. Since the core is made of conducting material, these EMFs, circulates currents within the body of the material. These circulating currents are called Eddy Currents.
- They will occur when the conductor experiences a changing magnetic field. As these currents are not responsible for doing any useful work, and it produces a loss (I^2R loss) in the magnetic material known as an **Eddy Current Loss**. The eddy current loss is minimized by making the core with thin laminations.

The equation of the eddy current loss is given as, $P_e = K_e B_m^2 t^2 f^2 V \text{ watts}$

Where, K_e – co-efficient of eddy current. Its value depends upon the nature of magnetic material like volume and resistivity of core material, thickness of laminations

- B_m – maximum value of flux density in wb/m²
- T – thickness of lamination in meters
- F – frequency of reversal of magnetic field in Hz
- V – volume of magnetic material in m³

2.7.2. Copper Loss Or Ohmic Loss

- These losses occur due to ohmic resistance of the transformer windings. If I_1 and I_2 are the primary and the secondary current. R_1 and R_2 are the resistance of primary and secondary winding then the copper losses occurring in the primary and secondary winding will be $I_1^2 R_1$ and $I_2^2 R_2$ respectively. Therefore, the total copper losses will be, $P_c = I_1^2 R_1 + I_2^2 R_2$
- These losses vary according to the load and known hence it is also known as variable losses. Copper losses vary as the square of the load current.

2.7.3. Stray Loss

The occurrence of these stray losses is due to the presence of leakage field. The percentage of these losses are very small as compared to the iron and copper losses so they can be neglected.

2.7.4. Dielectric Loss

- Dielectric loss occurs in the insulating material of the transformer that is in the oil of the transformer, or in the solid insulations. When the oil gets deteriorated or the solid insulation get damaged, or its quality decreases and because of this, the efficiency of transformer is effected

2.7.5. Efficiency of the Transformer

Transformer efficiency is defined as the ratio of the output power to the input power and is expressed as

$$\eta = \frac{\text{output power}}{\text{input power}} = \frac{\text{output power}}{\text{output power} + \text{losses}}$$

2.8 ALTERNATOR

An alternator is an electrical machine producing alternating emf (Electromotive force or voltage) of constant frequency. In our country the standard commercial frequency of AC supply

is 50 Hz. In U.S.A. and a few other countries the frequency is 60 Hz. The AC voltages generated may be single phase or 3-phase depending on the power supplied. For low power applications single phase generators are preferable. The basic principles involved in the production of emf and the constructional details of the alternators are discussed below.

Construction

Alternators work on the basic principle of electromagnetic induction similar to D.C generator. They also consist of an armature winding and a magnetic field. In D.C generator, the armature rotates and the field system is stationary. In alternator, the armature is stationary and the field system rotates.

In alternators, the armature winding is mounted on stator and field windings are placed on rotor. The details of construction are shown in Fig.2.13.

www.binils.com

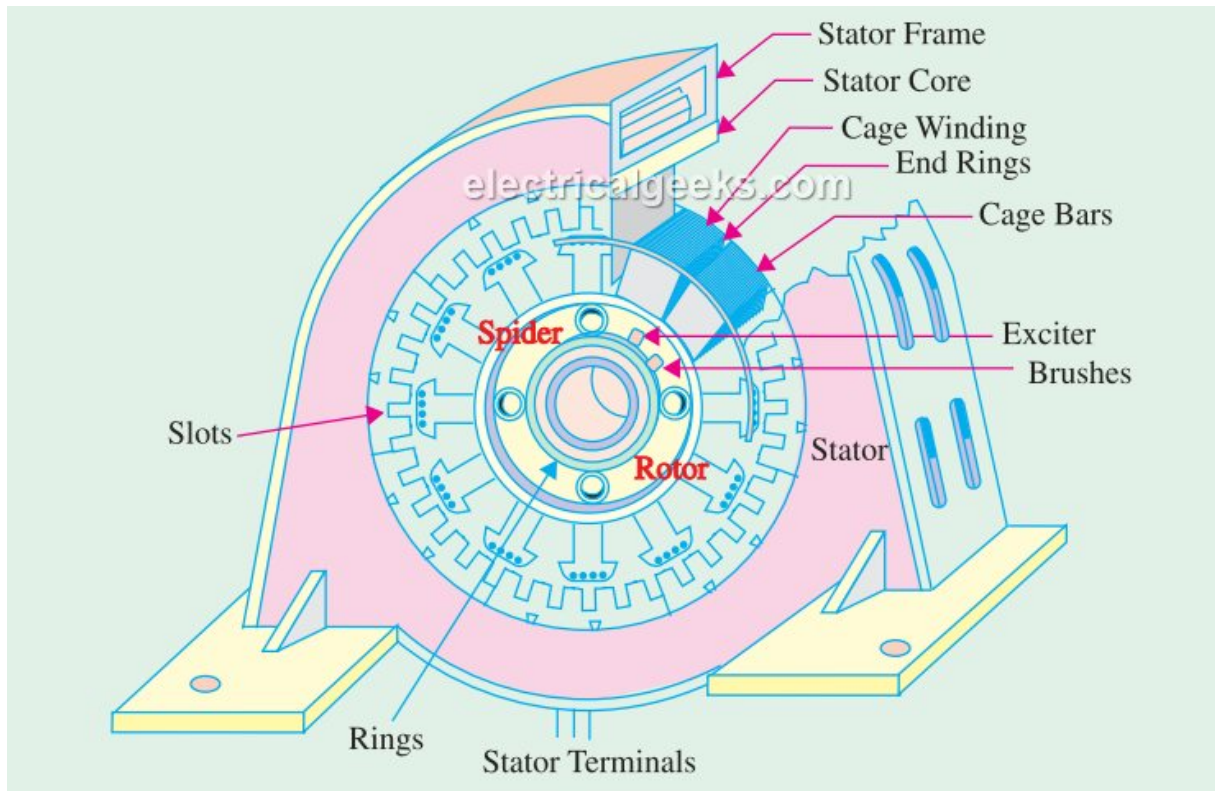

www.binils.com

Fig. 2.13. Cross sectional view of alternator

Stator

The stator consists of cast iron frame, which supports armature core. It has the slots on its inner periphery for housing the armature conductors.

The armature core is made of laminations of special magnetic iron or steel alloy. The core is laminated to reduce eddy current loss. The laminations are stamped out in complete rings for small machines or in segments for large machines. These laminations are insulated from each other. The slots for housing the armature conductors lie along the inner periphery of the core. Different types of the armature slots are shown in Fig.2.14.

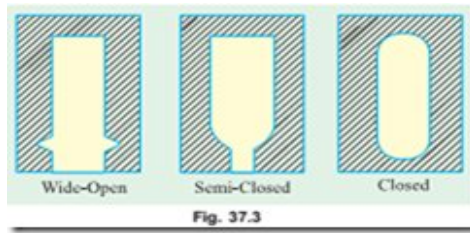

Fig. 2.14 Types of armature slots

Rotor

Two types of rotors are used in alternators.

1. Salient pole type
2. Smooth cylindrical type

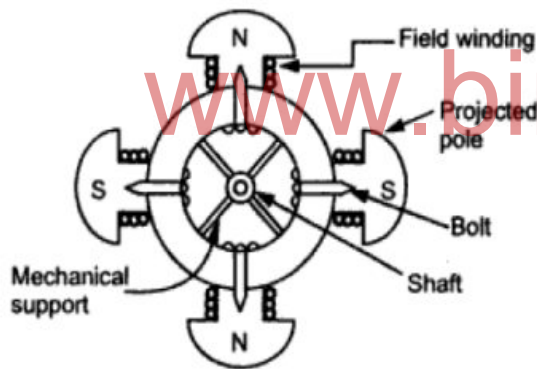

Fig. 2.15 a. Salient pole rotor

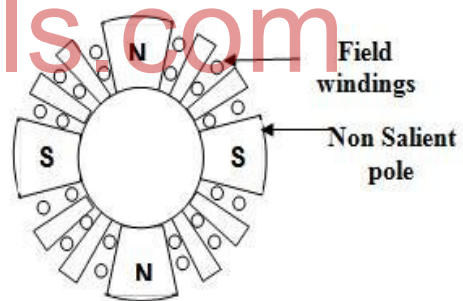

Fig. 2.15 b Cylindrical rotor

Salient pole type

Salient pole types are projecting in nature. It is used in low and medium speed alternators. It is used for engine driven alternators. It has a large number of projecting poles, having their

cores bolted or dove tailed on to a heavy magnetic wheel of cast iron. Salient pole alternator has large diameter and smaller axial lengths. The poles and pole shoes are laminated to minimize eddy current loss. In large machines, field winding consists of rectangular copper strip wound on edge.

Smooth cylindrical type

It is used for turbo driven alternators (turbo alternators). Turbo alternators run at very high speeds. The rotor consists of a smooth solid forged steel cylinder, having number of slots along the outer periphery. The field coils are placed in the slots. Such rotors are mostly designed for 2 poles or 4 poles as shown in Fig. 2.15b.

From the Fig.2.15b, it is observed that the central polar areas are surrounded by the field windings placed in the slots. In this case, the poles are non salient. They do not project out from the surface of the rotor. This makes the rotor to have smooth cylindrical surface. To avoid excess peripheral velocity at high speeds, these rotors have smaller diameter (about 1 meter). Hence turbo alternators are characterized by small diameter and larger axial length.

The cylindrical rotor gives better balance and quieter operation.

Damper windings

Damper windings are the copper bars are placed in the pole shoes as shown in Fig. 4. The copper bars are short circuited at both ends by heavy copper rings. These damper windings are used to prevent hunting (momentary speed fluctuations) in alternators.

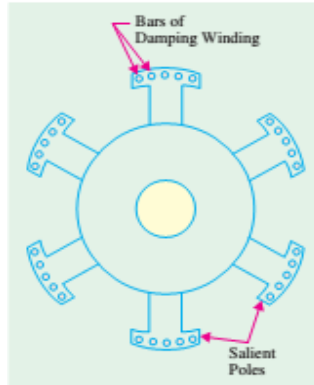

Fig. 37.6

Fig. 2.16 Damper winding of salient pole rotor

Working principle of alternator

Alternator works on the principle of Faraday's law of electromagnetic induction.

For understanding the working of alternator, let us consider a single rectangular turn placed in between two opposite magnetic poles as shown in fig. 2.17. This single turn loop ABCD can rotate about its own axis in a uniform magnetic field produced by either permanent magnets or electro magnets. The two ends of the coil are joined to two slip rings 'a' and 'b'. Two collecting brushes press against the slip rings. The function of the brush is to collect the current induced in the coil and to pass it to external load resistance R. The rotating coil is called as armature and the magnets are called as field magnets.

Assume the coil is rotating in clockwise direction as shown in fig 5C. As the coil moves through successive different positions in the field, the flux linked with it changes. Hence, an emf is induced in it which is proportional to the rate of change of flux linkages.

$$e = N \cdot \frac{d\phi}{dt}$$

At $\theta = 0$

When the plane of the coil is at position 1 (right angle to lines of flux), then flux linked with the coil is maximum. But rate of change of flux linkage is minimum. Hence, no emf is induced in the coil. Let us take the position 1 as starting position. As the coil is rotating in clockwise direction, the rate of change of flux linkages increases.

At $\theta = 90$

When the coil reaches position 3, (parallel to the axis of flux), then flux linked with the coil is minimum. But rate of change of flux linkage is maximum. Hence, maximum emf is induced in the coil at this position. In the next quarter revolution from 90 to 180, the flux linked with the coil gradually increases. But the rate of change of flux linkages decreases. Hence the induced emf gradually decreases.

At $\theta = 180$

When the coil reaches position 3, (right angle to the axis of flux), then flux linked with the coil is maximum. But rate of change of flux linkage is minimum. Hence, no emf is induced in the coil at this position.

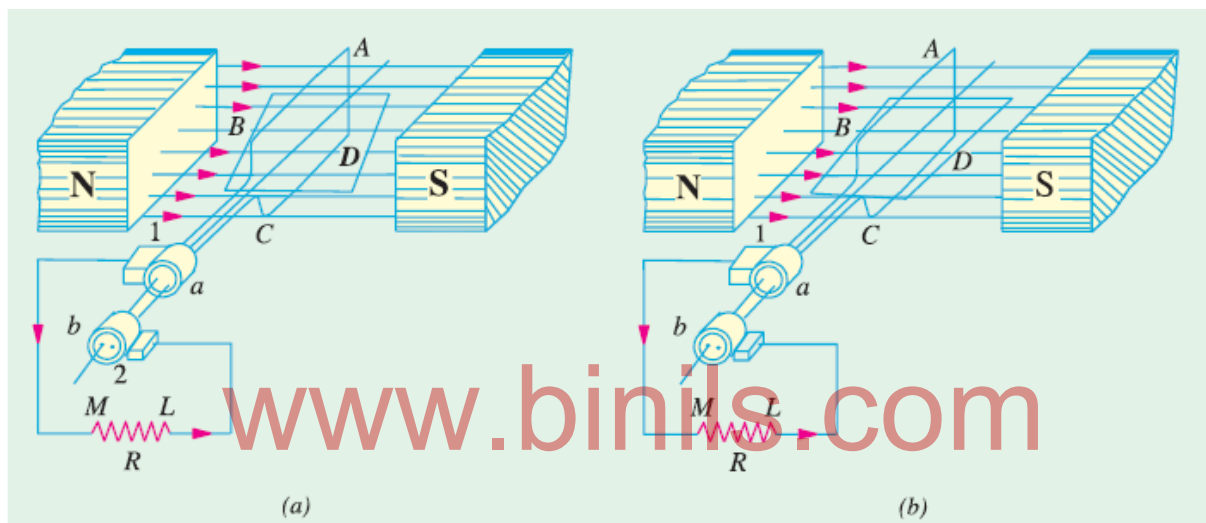

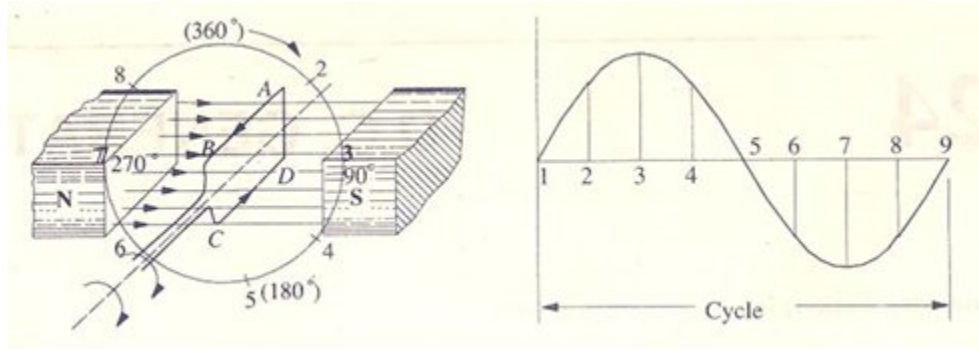

(c)

(d)

Fig 2.17. Emf induced in a single turn coil

Hence, in the first half of the revolution of coil, no emf is induced in position 1, maximum emf is induced in position 3 and no emf is induced in position 5. The direction of the induced emf can be found by Fleming's right hand rule. The emf is induced in the direction A to B and C to D.

In the next half of the revolution ($\theta = 180$ to $\theta = 360$), the variation of magnitude of the emf is same as first half of the revolution. The induced emf is maximum at position 7 and minimum at position 1. But the direction of induce current is from D to C and B to A as shown in Fig. 2.17d.

Therefore, we find that the current obtained from a simple generator reverses its direction after every half revolution. Such current is called as alternating current.

The relationship between the frequency of the induced emf and speed of the alternator is given below.

Let P= Total number of magnetic poles

N = Speed of the rotor in r.p.m

F = Frequency of the generated emf in Hz.

Since one cycle of emf is produced when a pair of poles passes past a conductor, the number of cycles of emf produced in one revolution of the rotor is equal to the number of pair of poles.

$$\text{No. of cycles / revolution} = P/2$$

$$\text{No. of revolutions / second} = N/60$$

$$\text{Frequency} = P/2 * N/60$$

$$= PN / 120 \text{ Hz.}$$

N is known as synchronous speed.

Synchronous speed is the speed at which an alternator must run, in order to generate the emf of required frequency.

Applications

1. Used in generating stations to generate electric power
2. Used in modern auto mobiles to charge battery
3. Diesel engine driven alternators are used in traction to supply power to traction motors
4. Used in marines.

A.C Machines

A.C system is universally adopted for distribution of electric energy to various industrial consumers and lighting loads. Hence 3 phase A.C motors are widely used in industrial environment. As a result, various types of a. c motors suitable for all classes of industrial drives and residential usage operates on three phase and single phase A.C supply are developed.

SINGLE PHASE AC MOTORS

Motors designed to operate with single phase, 230 Volt, 50 Hz supply are called single phase motors. Such motors are widely used in home, offices, factories, workshops and business environments.

Based on the construction and method of starting, single phase motors are classified in to following types.

1. Induction motors
 - a) Split phase type
 - b) Shaded pole type
 - c) Capacitor start type
2. Repulsion motors
3. A.C series motors
4. Un excited synchronous motors

Capacitor start induction motor

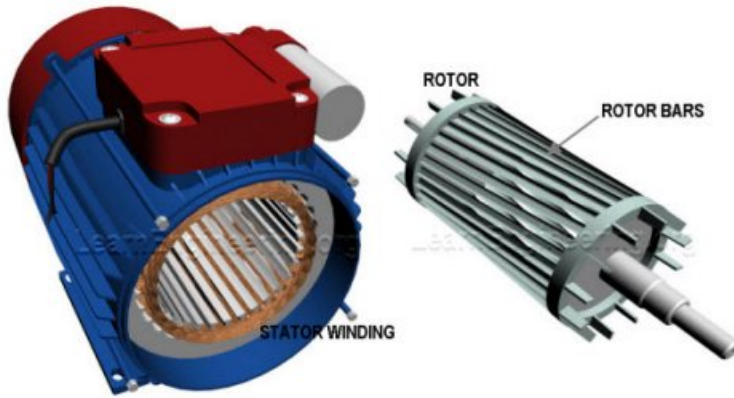

Fig. 2.18. Model of single phase induction motor

Construction

Construction of a single phase induction motor is similar to the construction of three phase induction motor having a squirrel cage rotor, except that

1. The stator is wound for single phase supply
2. Centrifugal switch is used in motors to cut out starting winding during running.

It has a distributed stator winding and a squirrel cage rotor.

When stator winding is fed with a single phase supply, it produces alternating flux only. It does not produce synchronously revolving flux. The alternating or pulsating flux acting on a stationary squirrel cage rotor cannot produce rotation. Hence single phase motors are not self-starting.

However, if the rotor of single phase machine is given an initial start by hand in either direction, the torque is developed and the motor accelerates to its rated speed.

In order to make the single phase induction motor as self-starting, it is temporarily converted into a two phase motor during starting period. Stator is also provided with an additional winding known as 'starting winding' in addition to the main or running winding. These two windings are spaced 90° electrically apart. They are connected in parallel across a single phase AC supply. In order to produce the high starting torque, the phase difference between the currents

in two windings should be closer to 90° . The connection of capacitor start induction motor is shown in Fig. 2.19a

Working

In capacitor start induction motor, a capacitor is connected in series with starting winding to produce the necessary phase difference between starting winding and running winding currents. The centrifugal switch allows the connection of starting winding only during the starting period. The capacitor used is generally of electrolytic type. It is mounted on the outside of the motor as a separate unit. The capacitor is designed for short duty service.

When the motor reaches about 75 % of full speed, the centrifugal switch opens and cuts off of starting winding and capacitor from the supply. It leaves only running winding across the supply.

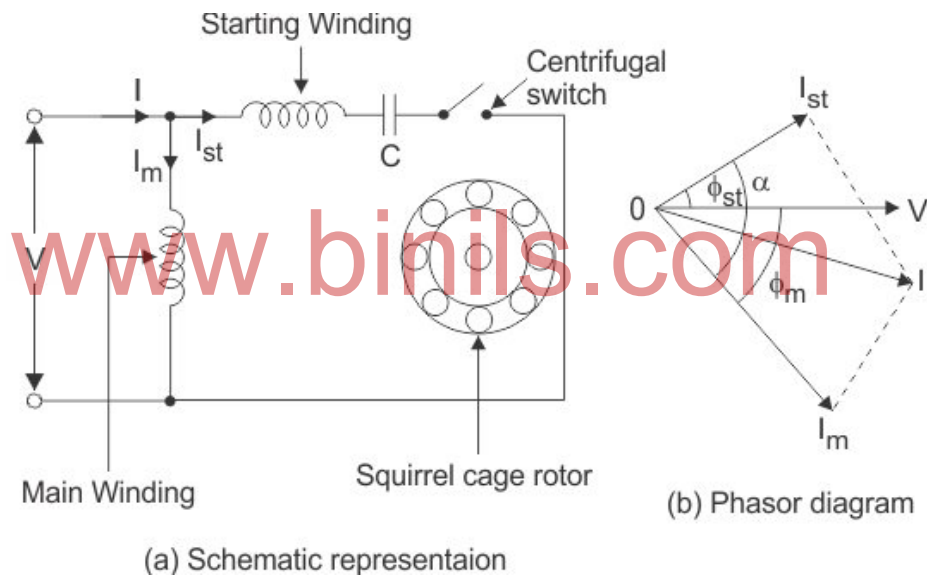

Fig. 2.19 Connection and phasor diagram

The phasor diagram is shown in Fig. 2b.

Let, V = Single phase AC supply voltage

I_m = Current through the main winding

I_{st} = Current through the starting winding

I = Current consumed from the power supply

α = phase angle between I_m and I_{st}

The current I_m drawn by the main winding lags the supply voltage by a large angle ϕ_m .

The current I_{st} drawn by the starting winding leads the supply voltage by a large angle ϕ_{st} .

The two currents I_m and I_{st} are out of phase by an angle α which is approximately 80° .

The resultant current I is almost in phase with the supply voltage.

Torque produced by the single phase motor is proportional to the sine of angle between two winding currents. As the value of α is 80° , this type of motor produces high starting torque (350 to 400 %) than standard split phase induction motor.

The performance characteristic is shown in Fig. 2.20

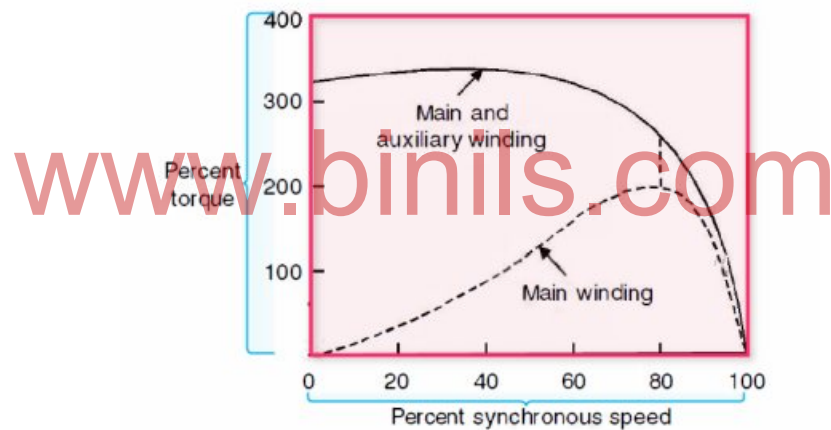

Fig. 2.20. Performance characteristics

Applications

It is used in fans, blowers, centrifugal pumps, washing machine, wet grinder, drilling machine and compressors.

UNIVERSAL MOTOR

It is a motor operates on either D.C supply or single phase AC supply at approximately same speed and same output.

Its construction is similar to dc series motor with some modifications. It produces high starting torque and variable speed characteristics. It runs dangerously high speed at no load. Most of the universal motors are designed to operate at higher speeds, exceeding 3500 RPM. They run at lower speed on AC supply than they run on DC supply of same voltage, due to the reactance voltage drop which is present in AC and not in DC. There are two basic types of universal motor:

- (i) concentrated pole and non-compensated type (low power rating)
- (ii) distributed field and compensated type (high power rating)

Construction

www.binils.com

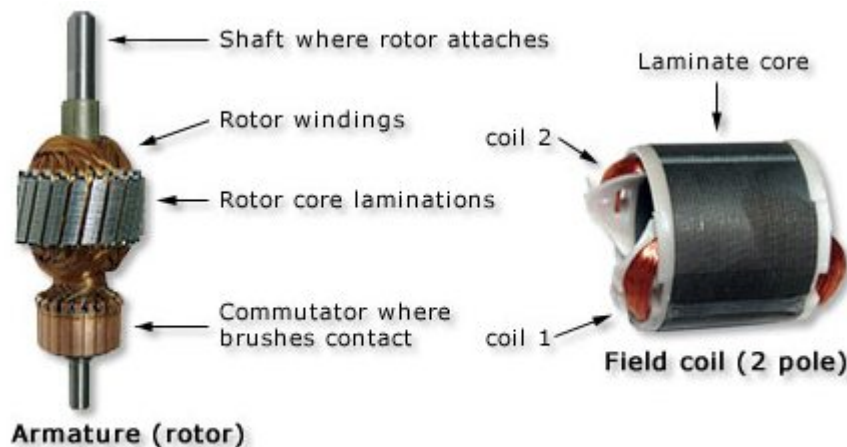

Fig. 2.21. Model of universal motor

Construction of a universal motor is very similar to the [construction of a DC machine](#). It consists of a stator on which field poles are mounted. Field coils are wound on the field poles. However, the whole magnetic path (stator field circuit and also armature) is laminated. Lamination is necessary to minimize the eddy currents which induce while operating on AC. The rotary armature is of wound type having straight or skewed slots and commutator with brushes resting on it. The armature windings are connected to commutator segments. In an uncompensated type motor, the commutation on AC is poorer than that for DC, because of the current induced in the armature coils. For that reason, brushes used are having high resistance.

Working principle

A universal motor works on either DC or single phase AC supply. The connection diagram of universal motor is shown in Fig. 2.22.a.

When the universal motor is fed with a DC supply, it works as a DC series motor. When current flows in the field winding, it produces an electromagnetic field. The same current also flows from the armature conductors. When a current carrying conductor is placed in an electromagnetic field, it experiences a mechanical force. Due to this mechanical force, or torque, the rotor starts to rotate. The direction of this force is given by Fleming's left hand rule.

When fed with AC supply, it still produces unidirectional torque. Since, the armature winding and field winding are connected in series, they are in same phase. Hence, as polarity of AC changes periodically, the direction of current in armature and field winding reverses at the same time.

Thus, direction of magnetic field and the direction of armature current reverses in such a way that the direction of force experienced by armature conductors remains same. Thus, regardless of AC or DC supply, universal motor works on the same principle that DC series motor works.

Characteristics

Torque -Speed characteristics of a universal motor is similar to that of DC series motor. The speed of a universal motor is low at full load and very high at no load. Usually, gears trains

are used to get the required speed on required load. The torque-speed characteristics are (for both AC as well as DC supply) are shown in the Fig. 2.22b.

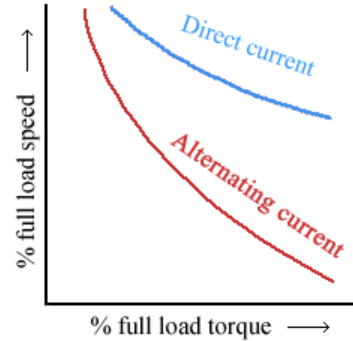
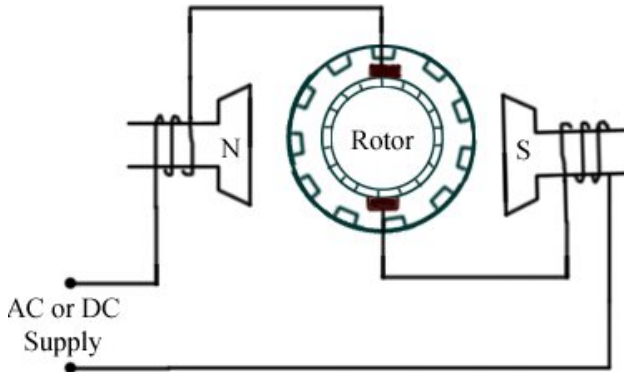

Fig. 2.22a. Connection diagram

Fig. 2.22b. Characteristics

Applications of Universal Motor

- Universal motors find their use in various home appliances like vacuum cleaners, drink and food mixers, domestic sewing machine etc.
- The higher rating universal motors are used in portable drills, blenders etc.

3 PHASE A.C MOTORS

Three phase A.C motors are widely used in industries. They are classified into various groups from the following different points of view:

1. Based on their principle of operation

(A) Synchronous motors

- i. plain
- ii. super

(B) Asynchronous motors

a. **induction motors**

- i. Squirrel cage (Single and double)
- ii. Slip-ring (external resistance)

b. commutator motors

- i. series (single phase universal)
- ii. compensated (conductively inductively)
- iii. shunt (single compensated)
- iv. repulsion (straight compensated)
- v. repulsion (start induction)
- vi. repulsion induction

2. Based on the type of current

- i. single phase
- ii. three phase

3. Based on the speed

- i. Constant speed
- ii. Variable speed
- iii. Adjusted speed

Construction of 3 phase induction motor

Of all the above types, 3 phase induction motor is widely used in industrial drives.

The construction of it is discussed below. The three phase induction motor consists essentially of two main parts:

- a. Stator and
- b. Rotor

1. Stator construction

The stator of an induction motor is, in principle, the same as that of alternator. The various parts of 3 phase induction motor is shown in Fig.2.23.

a. Stator frame

It is in the form of cylinder. It is made of cast iron and used for supporting the stator core. Terminal box is fixed in the outer surface. At both ends of the stator frame, provision is made to fit the end bells. Eye bolt is fitted at the top of frame. Eye bolts are used for lifting the motor. Cooling fan is used for cooling the motor through air ventilation.

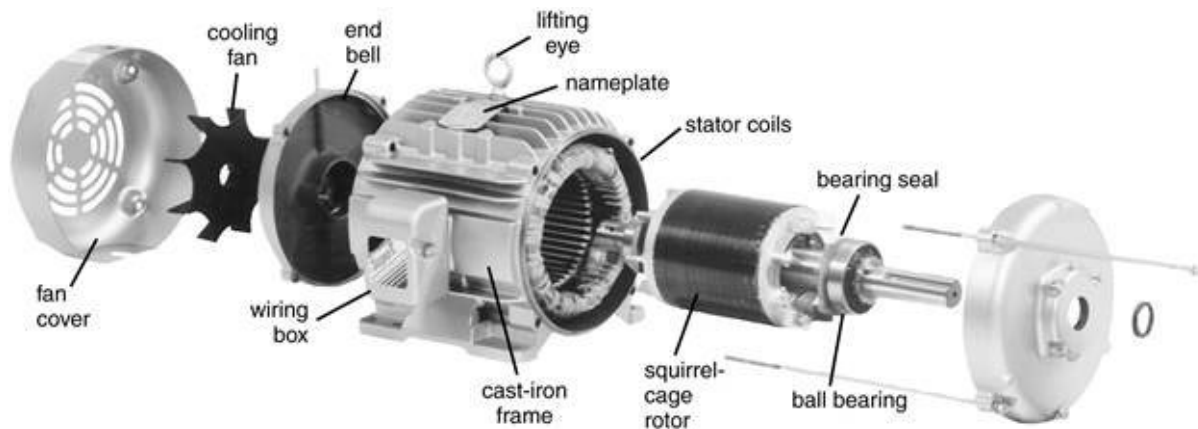

Fig.2.23. Parts of 3 phase induction motor

c. Stator core

www.binils.com

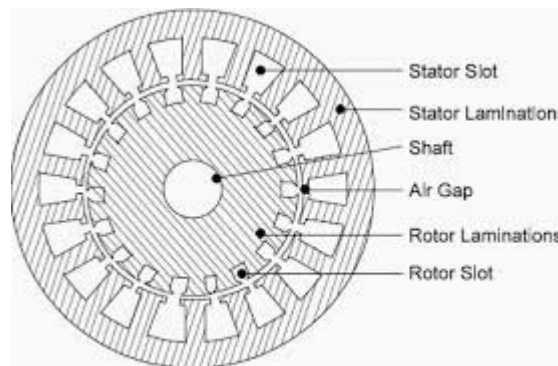

Fig. 2.24. stator and rotor core

It is made up of number of silicon steel stampings. The core is laminated to reduce eddy current loss. The laminated core is punched and bolted together with the frame. The core is

slotted along its inner periphery. The three phase winding fed from a three phase supply is placed in the slots. The winding is wound for a defined number of poles. The exact number of poles is determined by the requirement of speed. Greater the number of poles, lesser the speed and vice versa.

2. Rotor

Three phase induction motors are classified into two types according to the construction of rotor.

- i. Squirrel-cage rotor: motors employing this type of rotor are known as squirrel-cage induction motors
- ii. Phase-wound or wound rotor: motors employing this type rotor are variously known as 'phase-wound' motors or 'wound' motors or as 'slip-ring' motors.

a. Squirrel-cage Rotor

Almost 90 percent of induction motors are squirrel-cage type, because this type of rotor has the simplest and most rugged construction and is almost indestructible. The rotor consists of a cylindrical laminated core as shown in Fig 2.25. It consists of laminated silicon steel punching, bolted together and mounted on a shaft. The cylindrical core has the slots on the outside surface. Rotor conductors made of heavy bars of copper, aluminium or alloys are placed in the rotor slots. One bar is placed in each slot, rather the bars are inserted from the end when semi-closed slots are used. The rotor bars are brazed or electrically welded or bolted to two heavy and stout short circuiting end-rings. It looks like squirrel-cage construction.

It should be noted that the rotor bars are permanently short-circuited on themselves, hence it is not possible to add any external resistance in series with the rotor circuit for starting purposes.

The rotor slots are usually not quite parallel to the shaft but are purposely given a slight skew. Skewing is done to avoid magnetic locking of stator and rotor and to reduce magnetic hum.

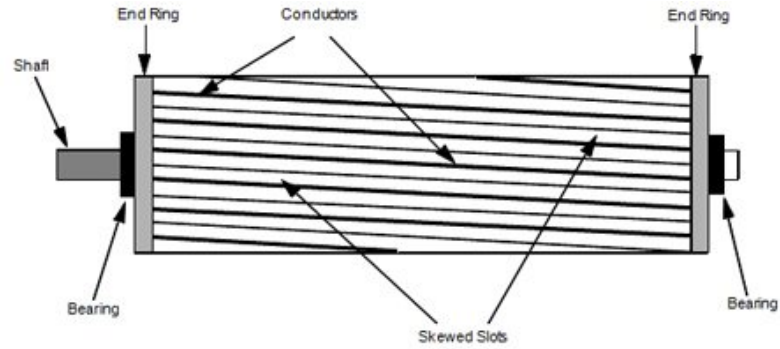

Fig 2.25. Squirrel cage rotor

b. Slip ring Rotor (Phase-wound Rotor)

Slip ring rotor is also made of silicon steel laminations. This type of rotor is provided with three phase, double-layer, distributed winding consisting of coils as used in alternators. The rotor is wound for as many poles as the number of stator poles. The rotor is always wound for three phase even when the stator is wound for two-phase.

The connection of rotor winding is shown in Fig.2.26. The three phase rotor windings are starred internally. The other three winding terminals are brought out and connected to the three insulator slip-rings mounted on the shaft with brushes resting on them. These three brushes are further externally connected to a three phase star-connected rheostat. By this arrangement the additional resistance can be added in the rotor circuit during the starting period to increase the starting torque of the motor, and for changing its speed-torque/current characteristics.

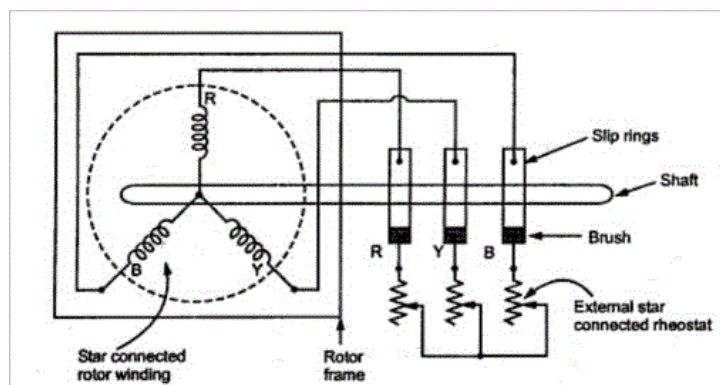

Fig. 2.26. Slip ring rotor connections

When running under normal conditions, the slip-rings are automatically short-circuited by means of a metal collar, which is pushed along the shaft and connects all the rings together. Next, brushes are automatically lifted from the slip-rings to reduce the frictional losses and the wear and tear. Hence it is seen that under normal running conditions, the wound rotor is short-circuited on itself just like the squirrel-cage rotor.

3. Stator and rotor windings- are insulated from each other and the core by embodying mica insulation and high quality varnishes.

4. Air-gap. A stator rabbets and bore are machined carefully to ensure uniformity of air-gap

5. Shafts and bearings. Ball and rollers bearing are used to suit heavy duty.

6. Fans.-light aluminium fans are used for adequate circulation of cooling air and are securely keyed onto the rotor shaft.

7. slip-rings and slip-ring enclosures. Slip-rings are made of high quality phosphor-bronze and are of moulded construction.

Working principle

When the three phase stator windings are fed by a three phase supply, a magnetic flux of constant magnitude, but rotating at synchronous speed, is set up.

$$\text{Synchronous speed } N_s = 120 * F / P$$

where F = Frequency of applied 3 phase voltage

P = No. of stator poles

This flux pass through the air gap, sweeps past the rotor surface and so cuts the rotor conductors which, as yet are stationary. Due to relative speed between the rotating flux and stationary conductors an e.m.f. is induced in the rotor conductors, according to faraday's law of electro-magnetic induction. The frequency of the induced e.m.f is the same as the supply frequency. Its magnitude is proportional to the relative velocity between the flux and conductor and its direction is given by Fleming's right-hand rule. Since the rotor bars or conductors form a closed circuit, rotor current is produced whose direction, as given as Lenz's law, in such as to oppose the very cause producing it. In this case, the cause which produce the rotor current is the relative velocity between rotating flux of the stator and stationary rotor conductor. Hence to reduce the relative speed, the rotor starts running in the same direction as that of the flux and tries to catch up with the rotating flux.

Of all ac motors, the poly phase induction motor is the one which is extensively used for various kind of industrial drives. It has the following main advantages and also some disadvantages:

Advantages:

- it has very simple and extremely rugged, almost unbreakable Construction (especially squirrel cage type)
- its cost is low and its very reliable
- it has sufficiently high efficiency. In normal running condition, no brushes are needed, hence frictional losses are reduced. It has a reasonably good power factor.
- It requires minimum of maintenance
- It starts up from rest and need no extra starting motors.

Disadvantages:

- It speed cannot be varied without sacrificing some of its efficiency.
- Just like dc shunt motor, it speeds decrease with increase in load.
- Its starting torque is somewhat inferior to that of a shunt motor.

Applications

- Squirrel cage motors have moderate starting torque and constant speed characteristics. Hence, they are preferred for driving fans, blowers, grinders, lathe machines, drilling machines, water pumps, printing machines etc.
- slip ring induction motors have high starting torque. Hence, they are used in lifts, hoists, elevators, cranes and compressors etc.

SPEED CONTROL OF INDUCTION MOTORS

A 3 phase induction motor is practically a constant speed motor, that means, for the entire loading range, change in speed of the motor is quite small. Speed of a DC shunt motor can be varied very easily with good efficiency, but in case of Induction motors, speed reduction is accompanied by a corresponding loss of efficiency and poor power factor. As induction motors are widely being used, their speed control is required in many applications. **Different methods of speed control of induction motor** are explained below.

Control from stator side

1. By changing the applied voltage:

This method is cheapest and the easiest. But it is rarely used because large change in voltage is required for small change in speed.

2. By changing the applied frequency

Synchronous speed of the rotating magnetic field of an induction motor is given by,

$$N_s = \frac{120 f}{P} \quad (\text{RPM})$$

where, f = frequency of the supply and P = number of stator poles.

Hence, the synchronous speed of the motor changes with change in supply frequency.

Actual speed of an induction motor is given as $N_r = N_s (1 - s)$.

However, this method is not widely used. In order to get the variable frequency, the speed of the prime mover of the alternator must be changed which is not so easy. Hence this method is rarely used.

3. By changing the number of stator poles

From the above equation of synchronous speed, it can be seen that synchronous speed (and hence, running speed) can be changed by changing the number of stator poles. This method is generally used for squirrel cage induction motors, as squirrel cage rotor adapts itself for any number of stator poles. Change in stator poles is achieved by two or more independent stator windings wound for different number of poles in same slots.

For example, a stator is wound with two 3phase windings, one for 4 poles and other for 6 poles.

For supply frequency of 50 Hz

i) synchronous speed when 4 pole winding is connected, $N_s = 120 \cdot 50 / 4 = 1500$ RPM

ii) synchronous speed when 6 pole winding is connected, $N_s = 120 \cdot 50 / 6 = 1000$ RPM

4. Constant V/F control of induction motor

This is the most popular method for controlling the speed of an induction motor. By keeping V/F constant, the developed torque remains approximately constant. This method gives higher run-time efficiency. Therefore, majority of AC speed drives employ constant V/F method (or variable voltage, variable frequency method) for the speed control. Along with wide range of speed control, this method also offers 'soft start' capability.

Speed control from rotor side:

1. Rotor resistance control

This method is only applicable to slip ring motors, as addition of external resistance in the rotor of squirrel cage motors is not possible. The speed of the motor is reduced by adding external resistance in the rotor circuit as shown in Fig. 2.27. Due to increase of rotor resistance, the rotor copper loss is increased. Hence efficiency of the motor is reduced. Hence this method is used, where the speed changes are needed for the short periods only.

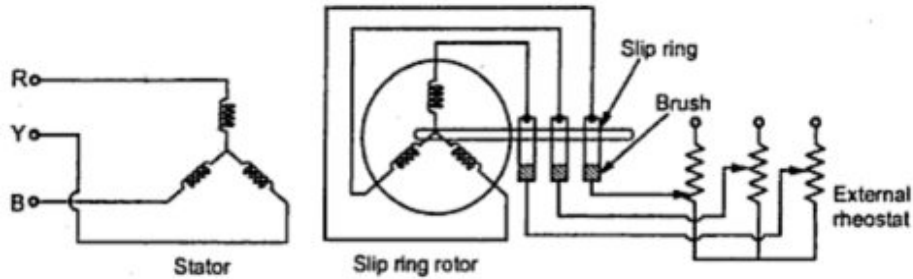

Fig. 2.27. Rotor resistance control

2. Cascade operation

In this method of speed control, two motors are used. Motor A is called the main motor and motor B is called the auxiliary motor. Both are mounted on a same shaft so that both run at same speed.

The stator winding of the main motor A is connected in the usual way. The stator of auxiliary motor B is fed from rotor circuit of motor A. The arrangement is as shown in following Fig. 2.28

There are four ways in which the combinations may be run.

1. Main motor A may be run separately from the supply. In this case,

$$\text{Synchronous speed } N_{sa} = 120 * f / P_a$$

where P_a = No. of stator poles of motor A.

2. Auxiliary motor B may be run separately from the supply (With motor A being disconnected). In this case,

$$\text{Synchronous speed } N_{sb} = 120 * f / P_b$$

where P_b = No. of stator poles of motor B.

3. The combination may be connected in cumulative cascade

In this method, the stator of auxiliary motor B is connected from rotor circuit of motor A in such a way that the phase rotation of the stator fields of both the motors are in the same direction. In this case,

$$\text{Synchronous speed } N_{sc} = 120 * f / (P_a + P_b)$$

4. The combination may be connected in differential cascade

In this method, the stator of auxiliary motor B is connected from rotor circuit of motor A in such a way that the phase rotation of the stator fields of both the motors are in the opposite direction. In this case,

$$\text{Synchronous speed } N_{sc} = 120 * f / (P_a - P_b)$$

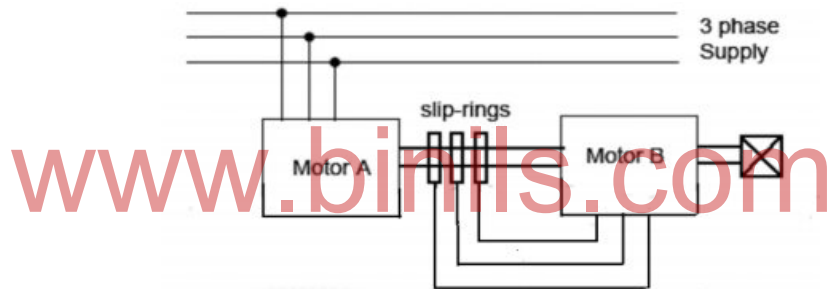

Fig .2.28 Cascade connection of motors

3. By injecting EMF in rotor circuit

In this method, speed of an induction motor is controlled by injecting a voltage in rotor circuit. It is necessary that voltage (emf) being injected must have same frequency as of the slip frequency. However, there is no restriction to the phase of injected emf. If we inject emf which is in opposite phase with the rotor induced emf, rotor resistance will be increased. If we inject emf which is in phase with the rotor induced emf, rotor resistance will decrease. Thus, by changing the phase of injected emf, speed can be controlled. The main advantage of this method is a wide

range of speed control (above normal as well as below normal) can be achieved. The emf can be injected by various methods such as Kramer system, Scherbius system etc.

NECESSITY OF STARTER:

An induction motor is similar in action to a transformer with a short circuited secondary. In an induction motor, rotor conductors are short circuited. Thus, if a normal supply voltage is applied to the motor, very large current is taken by the motor initially. At starting time, rotor is initially at rest position. Hence the e.m.f induced in the rotor is maximum value and it circulates very high current through the rotor. This condition is similar to a transformer with short circuited secondary. Similarly, in a three phase induction motor when rotor current is high, consequently the stator draws a very high current from the supply. This current can be in the order of 5 to 8 times of full load current at starting time. Due to such heavy inrush current, there is a possibility of damage of the motor winding. Also such high starting current causes large line voltage drop which will affect other loads. Hence in order to reduce the starting current of induction motors, starters are used.

The different type of starter used are listed below.

- i. D.O.L starter
- ii. Star-delta starter
- iii. Auto Transformer starter
- iv. Rotor Resistance starter

D.O.L Starter: (Direct Online Starter)

This type of starter is used for motor of less than 5 H. P rating. By using this starter, motors are started with rated line voltage. This type of starter connects stator directly to the supply line without any voltage reduction. Hence this starter is known as Direct Online Starter.

Fig. 2.29. shows the circuit diagram of a push button type DOL starter.

Power circuit

The three phase 440 V, 50 Hz supply is connected to motor through fuse, thermal overload relay and contactor. The contactor has 3 power contacts to control the supply input to the motor.

Control circuit

The ON push button has NO contact (normally open). The OFF push button has contact NC(normally closed). The thermal overload relay has NC contact. The NC contacts Off push button, thermal overload relay and NO contact of ON push button are connected in series with the contactor coil. The sealing contact of contactor is connected in parallel with ON push button.

Operation

For starting the motor, ON push button is pushed for fraction of second. Hence contactor coil gets energized and attracts the contactor. As the power contacts (M1, M2,M3) are closed, stator directly gets 3 phase supply. The sealing contact (M4) holds the coil in ON state even if the ON push button is de-pressed.

For stopping the motor, the OFF push button is pressed. Now the NC contact is opened and the coil circuit gets opened due to which coil gets de-energized and motor gets switched OFF from the supply.

Under over load condition, current drawn by the motor increases. Hence an excessive heat is produced in the motor, which increases temperature beyond limit. The NC contact of thermal relay gets opened due to high temperature, due to which coil gets de-energized and motor gets switched OFF from the supply. Thus, the motor is protected from overload conditions.

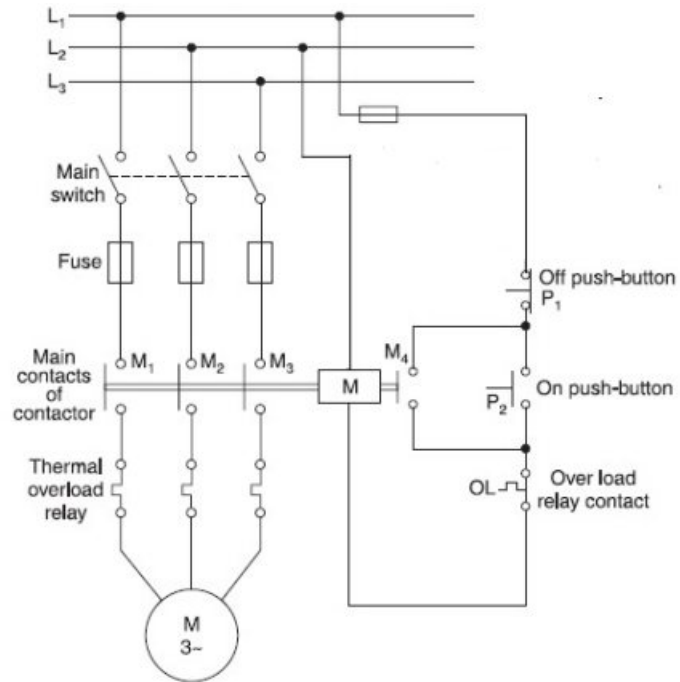

www.binils.com

Fig. 2.29. Connection diagram of DOL starter

This arrangement protects the motor from various severe abnormal conditions like over loading, low voltage, single phasing etc.

Advantages:

1. Simple construction
2. Easy to maintain
3. Low cost.

Dis advantages:

1. Used only small H.P motor
2. Starting current is high

STAR-DELTA STARTER

This type of starter is used for starting the induction motors which are running with delta connection normally. The connection diagram of Star – delta starter is shown in Fig. 2.30. It consists of a two-way switch. The switch connects the stator winding in Star at start and then delta for normal running.

During starting, the switch connects the motor in star. Hence per phase voltage gets reduced by the factor $1/\sqrt{3}$. (In star $V_{ph} = V_l/\sqrt{3}$). Due to this reduced voltage, the starting current is reduced to $1/\sqrt{3}$ times that of current taken with direct starting.

During running, when motor reaches 75 % of the rated speed, the switch is thrown on other side. Now the winding gets connected in delta, across the supply. So it gets normal rated voltage.

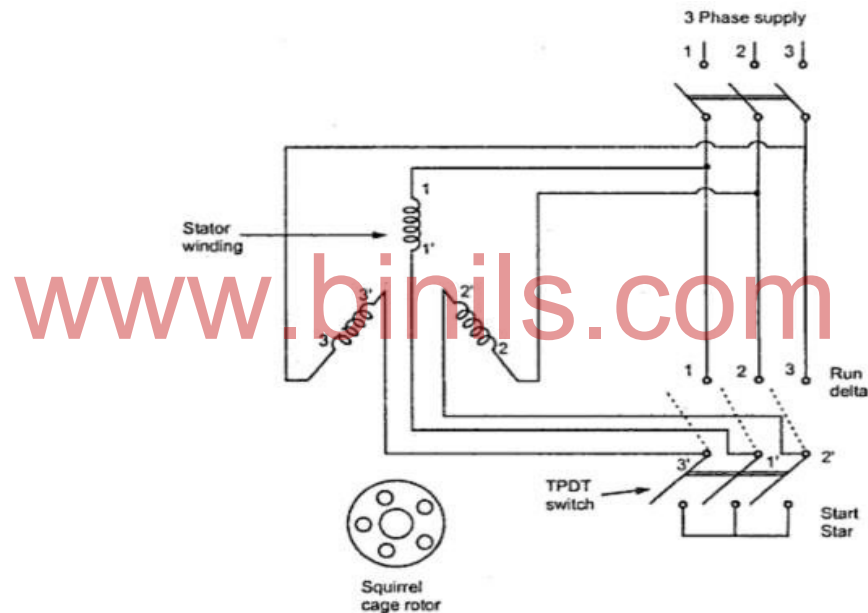

Fig. 2.30 Connection diagram of Star Delta starter

The operation of the switch can be automatic by using relay which ensures that motor will not start with the switch in Run position.

Advantages

1. cheap
2. Maintenance free operation

Disadvantages

1. It is suitable only for normal delta connected motors.

Applications

Used in machine tools, pumps, motor – generator sets

REVIEW QUESTIONS

PART-A

1. What is turn ratio of transformer?
2. State the working principle of transformer.
3. Draw the electrical equivalent of magnetic circuit.
4. Define peak value.
5. Define average value.
6. Write the EMF equation of transformer?
7. Write the necessity of starter in AC motor.
8. Write the applications of three phase induction motor?
9. Write the applications of single phase induction motor?
10. Define Power factor

PART-B

11. State the losses occurring in transformer. How to reduce it?
12. Compare the voltages in star and delta connected 3 phase system

13. Explain the working of DOL Starter?
14. What are the advantages of three phase system?
15. What are the methods of speed control of induction motor?
16. How can you reverse the direction of three phase induction motor?
17. Write the slip torque equation of induction motor and write what happen when the slip is zero?

PART-C

18. Describe the construction of a transformer
19. With a necessary diagram give the construction and working principle of a transformer and derive for voltage equation.
20. Derive the EMF equation of a single phase transformer
21. With a necessary diagram give the construction and working principle of Three phase induction motor?
22. Explain with neat diagram of speed control of induction motor from rotor side?
23. Draw and explain the working of star- delta starter?
24. Explain the working of single phase capacitor start induction motor
25. Explain the working of constructional details of salient pole alternator.

UNIT III

STEPPER AND SERVO MOTORS & DRIVES

3.1 PERMANENT MAGNET DC MOTOR (PMDC)

- If a permanent magnet is used to create magnetic field in a DC motor, the motor is referred to permanent-magnet dc motor or PMDC motor.

- It is similar to ordinary D.C. shunt motor except its field is provided by permanent magnets instead of Salient-pole wound field structure.

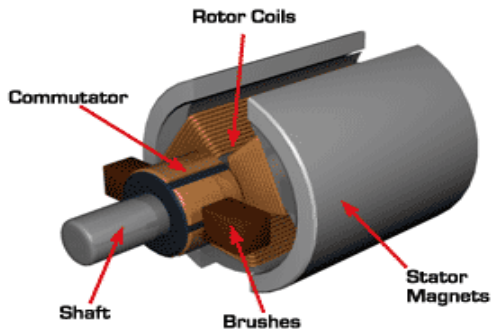

Fig.3.1 PMDC

www.binils.com

Construction

A PMDC motor mainly consists of two parts:

- (a) Stator and
- (b) Rotor (or) armature.

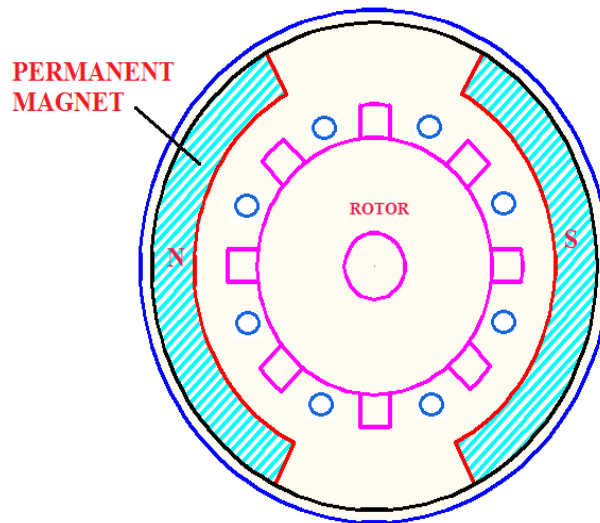

www.binils.com

Fig.3.2 PMDC

(a) Stator

- Here the stator which is a steel cylinder. The magnets are mounted in the inner periphery of this cylinder. The permanent magnets are mounted in such a way that the N – pole and S – pole of each magnet are alternatively faced towards armature.
- Another form of the stator construction is the one in which permanent-magnet material is cast in the form of a continuous ring instead of in two pieces as shown in Figure. The stator also serves as a return path for the magnetic flux.

(b) Rotor

- The rotor of PMDC motor is similar to other DC motor. The rotor or armature of permanent magnet DC motor also consists of core, windings and commutator.
- Armature core is made of number of varnish insulated, slotted circular lamination of steel sheets.

- By fixing these circular steel sheets one by one, a cylindrical shaped slotted armature core is formed.
- The varnish insulated laminated steel sheets are used to reduce eddy current loss in armature of permanent magnet dc motor.
- These slots on the outer periphery of the armature core are used for housing armature conductors in them. The armature conductors are connected in a suitable manner which gives rise to armature winding. The end terminals of the winding are connected to the commutator segments placed on the motor shaft
- . Like other DC motor, carbon or graphite brushes are placed with spring pressure on the commutator segments to supply current to the armature.

Permanent Magnets:

There are three types of permanent magnets used for such motors. .

- Alnico magnets – They are used in motors having ratings in the range of 1 kW to 150 kW.
- Ceramic (ferrite) magnets – They are much economical in fractional kilowatt motors.
- Rare-earth magnets – Made of samarium cobalt and neodymium iron cobalt which have the highest energy product. Such magnetic materials are costly but are best economic choice for small as well as large motors.

Working

- Most of these motors usually run on 6 V, 12 V or 24 V dc supply obtained either from batteries or rectified alternating current.
- The working principle of PMDC motor is similar to the general working principle of DC motor.
- In these motors torque is produced by interaction between the axial current-carrying rotor conductors and the magnetic flux produced by the permanent magnets.

Advantages

- No need of field excitation arrangement. No input power is consumed for excitation which improves efficiency of DC motor.
- No field coil hence space for field coil is saved which reduces the overall size of the motor.
- Cheaper and economical for fractional kW rated applications. Low voltage PMDC motors produce less air noise.

Disadvantages

- Since their magnetic field is active at all times even when motor is not being used, because of that their temperature tends to be higher.

- A more serious disadvantage is that the permanent magnets can be demagnetized by armature reaction. Demagnetization can result from (a) improper design (b) excessive armature current caused by a fault or transient (c) improper brush shift and (d) temperature effects.

Applications

- PMDC motor is extensively used where small DC motors are required and also very effective control is not required, such as in automobiles starter, toys, wipers, washers, hot blowers, air conditioners, computer disc drives, food mixer, ice crusher, drills, saber saws, portable vacuum cleaner, and shoe polisher.

3.2 STEPPER MOTOR

- Stepper motor is an electromagnetic energy conversion device that converts electrical pulse to discrete mechanical movements. These motors are also called step motor or stepping motor or stepper.
- Due to its nature of its working, it is primarily used for position control systems. A *step* in a stepper motor is defined as the angular rotation produced by the shaft of the motor each time it receives a pulse.

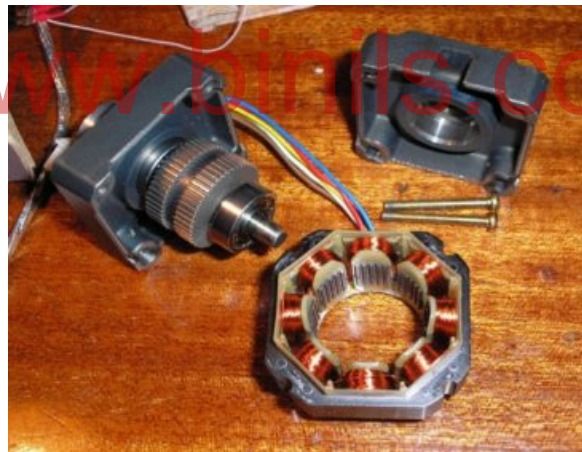

Fig.3.3: stepper motor

- Each step causes the shaft to rotate a definite number of degrees. The angle through which the motor shaft rotates for each command pulse is called the *step-angle* (β).

$$\text{Step angle} = 360^\circ / (\text{No. of stator phases} \times \text{No. of rotor teeth})$$

Based on the construction of the magnetic circuit there are three main types of motors:

- Permanent magnet (PM) stepper motor - High torque low angular resolution
- Variable reluctance (VR) stepper motor – Excellent angular resolution, low torque
- Hybrid (HY) stepper motor - combines structure of PM and VR steppers, provides good torque and angular resolution

3.2.1 Permanent magnet (PM) stepper motor

Construction

- It has wound stator poles and permanently magnetized rotor which is constructed in cylindrical shape. Its direction of rotation depends on the polarity of stator current.
- The rotor is on the inside, with permanent magnets mounted on its perimeter. The stator is on the outside, with electromagnets (called windings) inside slots. The controller energizes the windings with pulses of DC current.
- Many of the windings are connected together. Each group of connected windings forms a phase.

Working

- The stator has 12 windings and its rotor has six magnets mounted on its perimeter. PM steppers are generally two-phase motors. In the figure, the different phases are denoted A and B.

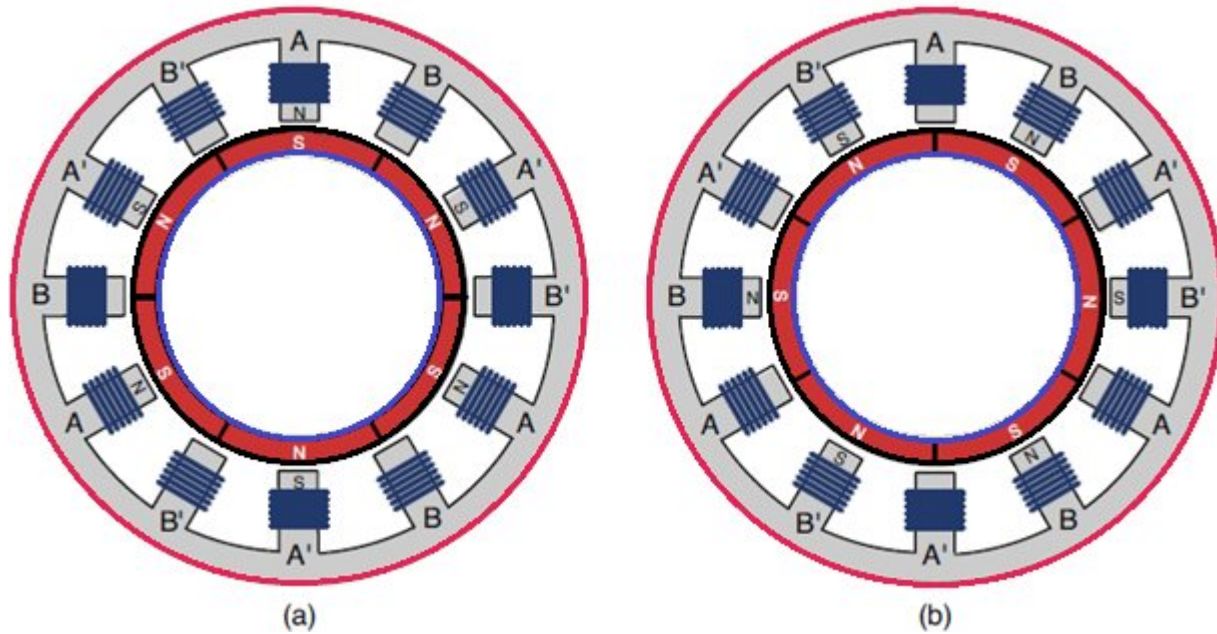

Fig 3.4: 30⁰ rotation of a PM stepper motor

- The windings labeled A' and B' receive the same current as those labeled A and B, but in the opposite direction.
- That is, if A behaves as a north pole, A' behaves as South Pole. Each winding has one of three states: Positive current, negative current, and zero current.
- Here, positive current implies a north pole and negative current implies a south pole. Figure 3.4 illustrates a single turn (30⁰ rotation) of a PM stepper motor.
- In the windings, a small "N" implies that the winding behaves like a north pole due to positive current. A small "S" implies that the winding behaves like a south pole due to negative current.
- If a winding doesn't have an N or S, it isn't receiving current. In Figure 3.4 a, A is positive (North Pole), A' is negative (South Pole), and Phase B isn't energized.
- The rotor aligns itself so that its south poles are attracted to the A windings and its north poles are attracted to the A' windings.
- In Figure 3.4 b, B is positive (North Pole), B' is negative (South Pole), and Phase A isn't energized.

- The rotor rotates so that its poles align with the B and B' windings. The rotation angle equals the angle between the A and B windings, which means the rotor turns exactly 30° in the clockwise direction.

3.2.2 Variable reluctance (VR) stepper motor

In a variable reluctance (VR) stepper motor, the rotor turns at a specific angle to minimize the reluctance between opposite windings in the stator.

Construction

- It has the wound stator same as that of permanent magnet type, but the rotor is non-magnetic.
- The rotor is made up of ferromagnetic material. When the stator pole is magnetized, the rotor teeth will align with the magnetized stator pole.
- It is called variable reluctance motor because the reluctance of the magnetic circuit formed by the rotor and the stator teeth varies with the angular position of the rotor.

There are two primary differences between VR steppers and PM steppers:

- Rotor — Unlike a PM stepper, the rotor in a VR stepper doesn't have magnets. Instead, the rotor is an iron disk with small protrusions called teeth.
- Phases — In a PM stepper, the controller energizes windings in two phases. For a VR stepper, the controller energizes every pair of opposite windings independently. In other words, if the stator has N windings, it receives N/2 signals from the controller.
- Figure 3.5 illustrates the rotor and stator of a VR stepper. In this motor, the stator has eight windings and the rotor has six teeth.
- The A and A' windings are labeled N and S, which shows how they're energized by the controller.
- The teeth in the rotor align with these windings to provide a path for magnetic flux between A and A'.

Working

- When the controller energizes a second pair of windings, the rotor turns so that a different pair of teeth will be aligned. Because the teeth aren't magnetized, it doesn't matter whether a winding behaves as a north pole or as a south pole.

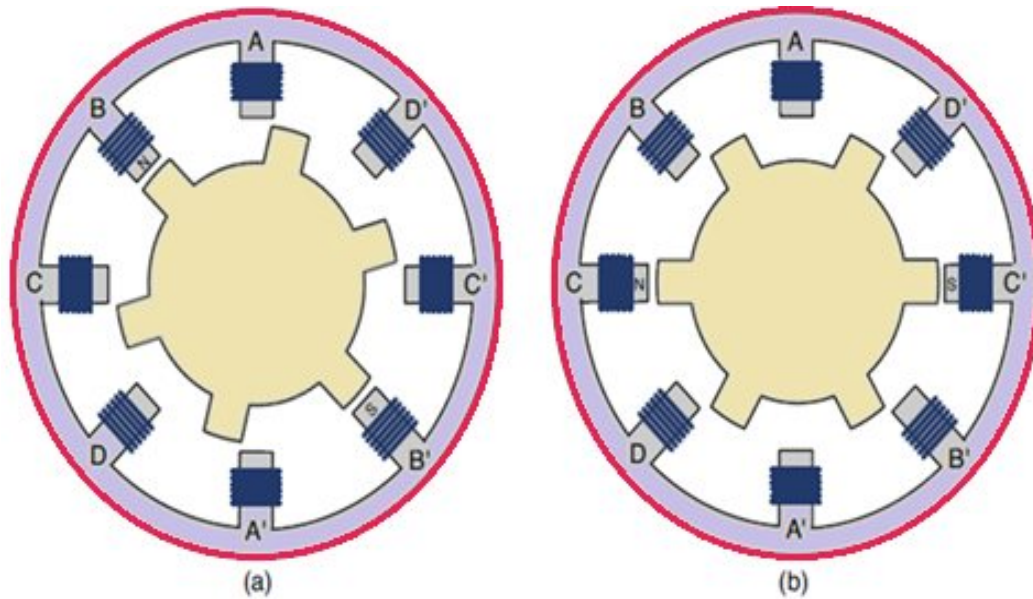

www.binils.com

Fig.3.5:15° rotation of VR stepper

- In Figure 3.5 a, the controller has delivered current to the B and B' windings, and the rotor has aligned itself accordingly.
- In Figure 3.5 b, the C and C' windings are energized. The C and C' windings attract the nearest pair of teeth, which moves the rotor 15° in the clockwise direction.
- If we know the number of windings in the stator (N_w) and the number of teeth on the rotor (N_t), the step angle of a VR stepper can be computed with the following equation:

$$\text{Step angle} = 360^\circ \times [(N_w - N_t) / N_w N_t]$$

- In Figure 3.5, N_w equals 8 and N_t equals 6. Therefore, the step angle can be computed as $360(2/48) = 15^\circ$. The angular resolution can be improved by increasing the number of windings and teeth.
- With the right structure, the step angle can be made much less than that of a PM stepper. But the torque of a VR stepper is so low that it can't turn a significant load. For this reason, VR steppers are not commonly found in practical systems.

3.2.3 Hybrid (HY) stepper motor

- Hybrid stepper motor combines features of both permanent magnet type as well as variable reluctance type motor.
- The rotor is of permanent magnet type and axially magnetized with radial soft iron teeth. It is best suited when small step angles of 1.8° , 2.5° etc. are required.

Construction

Its rotors and stators are different from those of PM and VR steppers but the principle of their operation is similar.

Rotor

- If we compare the HY stepper to the PM stepper, the HY stepper is longer. The reason for this is that the HY stepper rotor has (at least) two rotating mechanisms connected to one another. These are called rotor poles and are shown in Figure 3.6.

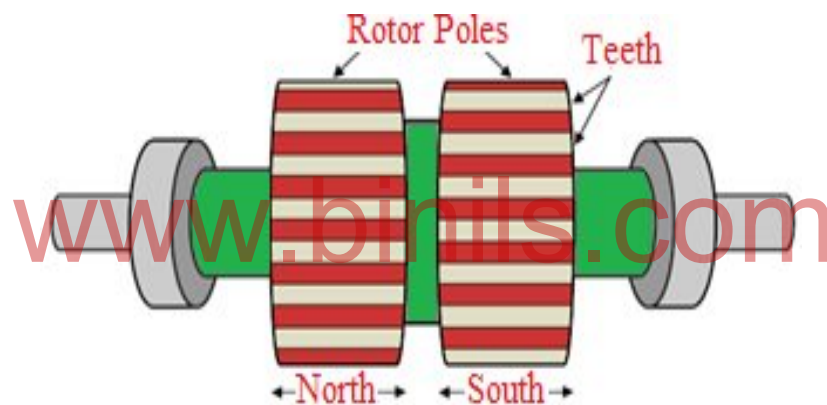

Fig.3.6: Rotor poles of an HY stepper

- The rotor poles are magnetized so that one behaves like a north pole and one behaves like a south pole.
- Each pole has its own teeth, and the teeth of one rotor pole are oriented between those of the other.
- The angular difference between the two sets of teeth determines the step angle of the motor.
- The more teeth the stepper has, the better the angular resolution. The rotor in Figure 3.7 has one pair of rotor poles, but other HY steppers may have two, three, or more pairs.

- Adding rotor poles increases the stepper's rotational torque and holding torque, but also increases its size and weight.

Stator

- The stator windings of a PM stepper or VR stepper are too large to attract/repel the teeth of one rotor pole without repelling or attracting the teeth of the other rotor pole.
- For this reason, the stator of an HY stepper has teeth that are approximately the same size as the teeth on the rotor. This is shown in Figure 3.7. .
- In this figure, each winding has three teeth. In a real stepper, the windings may have many more.
- If a winding is energized to produce a north pole, its teeth will attract the teeth of the rotor's South Pole.
- If a winding behaves as a south pole, its teeth will attract the teeth of the rotor's North Pole.

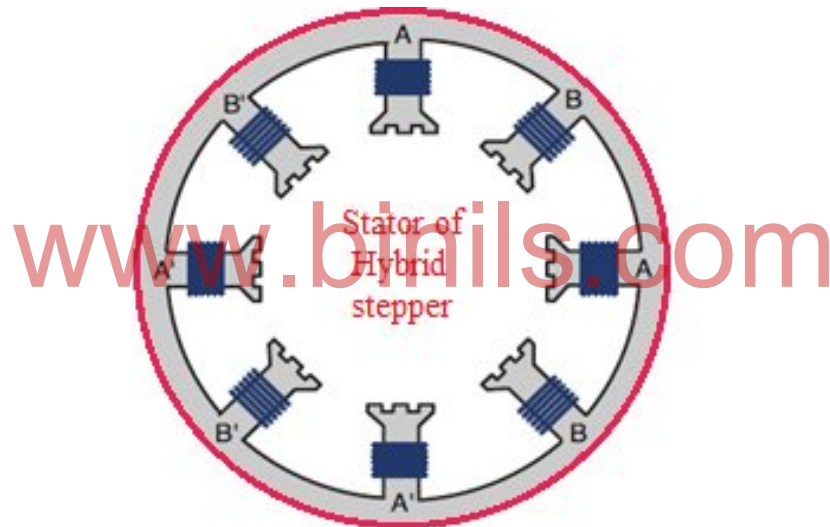

Fig.3.7: Toothed stator of an HY stepper

Working

- Like a VR stepper, an HY stepper can have multiple phases, one for each pair of windings. The windings are divided into two phases: A/A' and B/B'. These are the phases labeled in Figure 3.7.

- Each phase receives positive current, negative current, and zero current. When one phase is energized, its windings attract the teeth of one rotor pole.
- When the next phase is energized, its windings attract the teeth of the other rotor pole.
- Hybrid steppers commonly have 50–60 teeth on a rotor pole, which increases the angular resolution. It's common to see hybrid steppers with step angles as low as 1.8° and 0.9°.

Applications of Stepper Motors

- These motors are used for operation control in computer peripherals, textile industry, IC fabrications and Robotics etc.
- Applications requiring incremental motion are typewriters, line printers, tape drives, floppy disk drives, and X-Y plotters.

3.3 SERVO MOTOR

- The motor that are used in automatic control systems are called servomotors. When the objective of the system is to control the position of an object then the system is called servomechanism.
- The servomotors are used to convert an electrical signal applied to them into an angular displacement of the shaft.
- They can either operate in a continuous duty or step duty depending on construction.

3.3.1 Brushless servo motor

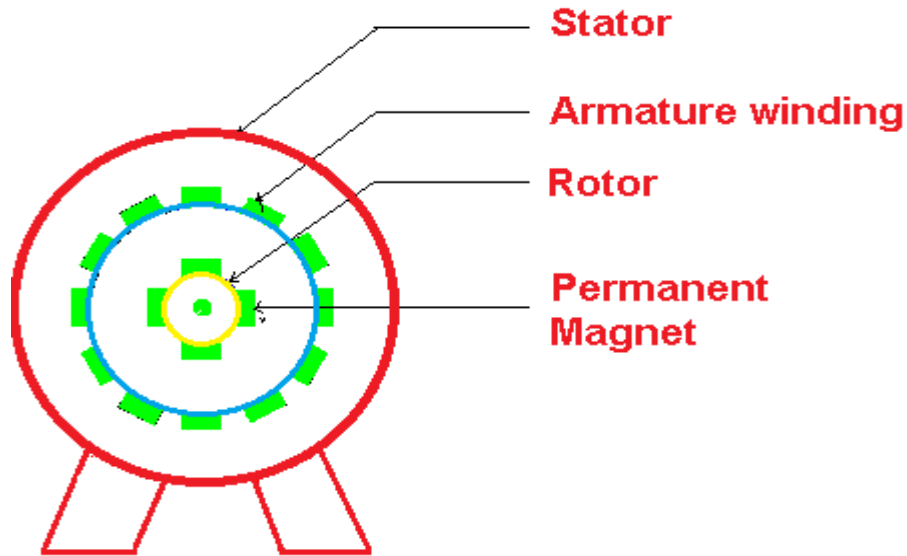

www.binils.com
Fig.3.8 Brushless servo motor

Construction

Stator

- Figure 3.8 shows the structure of brushless servo motor. The stator consists of an armature core and armature winding. The armature core is made of laminating punched silicon steel sheet of 0.35 to 0.5mm thickness.
- The armature windings are similar to A.C motor and are usually of distributed three phase type.
- The windings are designed according to the drive specification, which require either a sinusoidal or trapezoidal back emf wave form.
- The factors governing the design are number of stator slots, pole shape; windings coil pitch, number of rotor poles and magnet shape.

Rotor

- The rotor carries the permanent magnet and is fixed on the motor shaft. The shape of the magnet is either cylindrical or salient pole.
- Rare earth magnet has also used to improve the performance of the motor.

- They can be operated up to the boundary of high speed rotation without decreasing the maximum torque.
- The heat dissipated in the shaft diffuses in the air through the frame. It is therefore easy to cool the brushless servomotor.

Applications

These servomotors are best suited for low power applications. These motors are widely used in,

- Aircraft control systems,
- Electromechanical actuators, process controllers,
- Robotics, machine tools, used in instrument servos, computer etc.

3.3.2 Permanent magnet servo motor

Field control is not possible in the case of permanent magnet DC motor as the field is a permanent magnet here. DC servo motor working principle in that case is similar to that of armature controlled motor. In this type of motors, the field winding is replaced by permanent magnets to produce the required magnetic field. Permanent magnet motors are economical for power ratings up to a few kW.

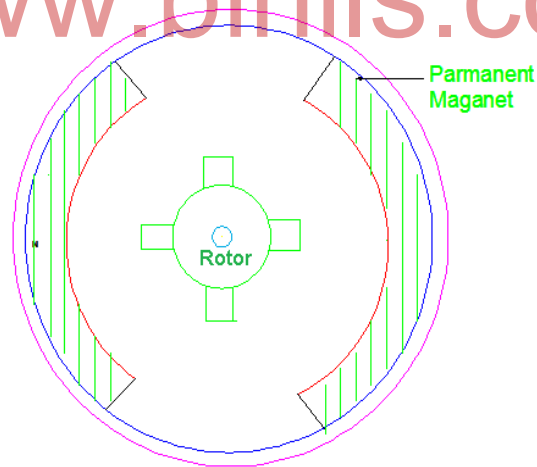

Fig.3.9 permanent magnet servo motor

Construction

- In permanent magnet motors, the armature is placed in rotor and permanent magnet poles are fixed to the stator.
- The rotor employs special type of constructions to reduce the weight and so the inertia of the rotating system.
- The special type of constructions is cylindrical armature with small diameter and longer axial length, disc armature and hollow armature.

Advantages

- A simpler, more reliable motor because the field power supply is not required.
- Higher efficiency
- Field flux is less affected by temperature rise.
- Less heating, no possibility of over speeding
- A more linear torque Vs speed curve.

Disadvantages

- The magnets deteriorate with time.
- The magnets demagnetized by large current transients.

Applications

1. Permanent magnet motors are commonly used in printers and disc drives, tape drives.
2. Used in industrial Robot.
3. Used in numerically controlled milling machines.

3.4 INDUSTRIAL DRIVES

Systems employed for motion control are called drives and may employ any of the prime movers such as, diesel or petrol engines, gas or steam turbines, steam engines, hydraulic motors and electric motors, for supplying mechanical energy for motion control.

If a drive used for industrial process it is called as industrial drive.

Drives employing electric motors are known as electrical drives.

Types of Electric Drives

The electric drives are classified into three types. They are

Group Drive B. Individual Drive C. Multi-motor Drive

A. Group Electric Drive

- This drive consists of a single motor, which drives one or more line shafts supported on bearings.

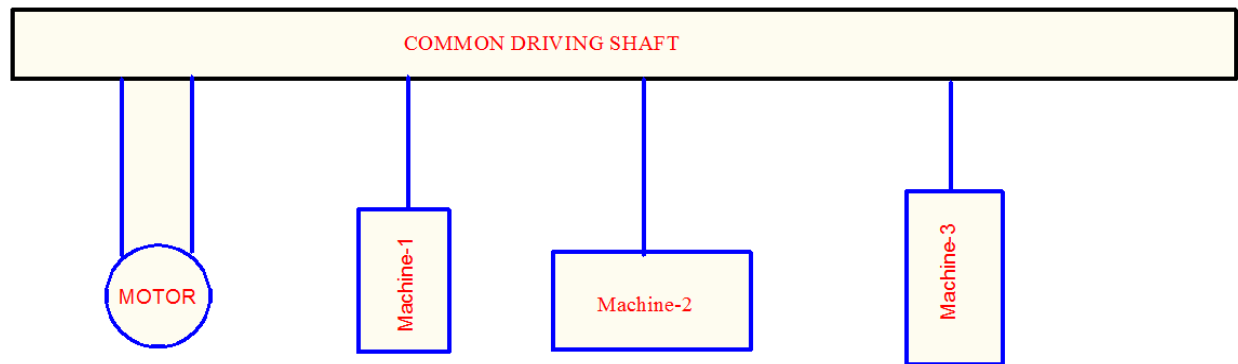

www.binils.com

Fig.3.10 Group drive

- The line shafts may be fitted with either pulleys and belts or gears, by means of which a group of machines or mechanisms may be operated.
- It is also sometimes called the shaft drive. Electric drive used in rice mill is an example for group electric drive.

Advantages

A single large motor can be used instead of a number of small motors.

The rating of the single large motor may be appropriately reduced taking into account the diversity factor of loads.

Disadvantages

There is no flexibility. If the single motor used develops fault, the whole process will come to stop.

Addition of an extra machine to the main shaft is difficult.

If some of the machines are not working, the losses are increased, thus decreasing the efficiency and power factor.

B. Individual Drive

- In this drive, each individual machine is driven by a separate motor. This motor also imparts motion to various other parts of the machine.
- Examples of such machines are Single spindle drilling machines (universal motor is used) and Lathes.

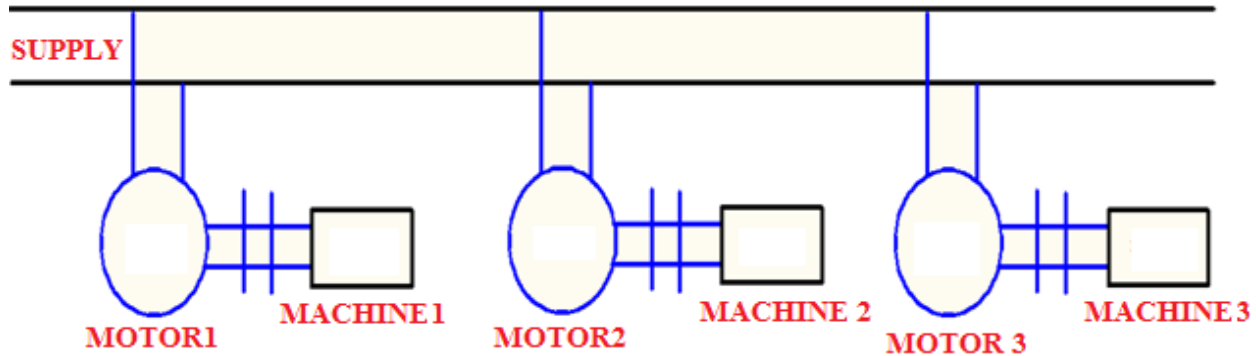

www.binils.com

Fig.3.11 Individual drive

- In a lathe, the motor rotates the spindle, moves the feed and also with the help of gears, transmits motion to lubricating and cooling pumps.
- A three-phase squirrel cage induction motor is used as the drive. In any such applications, the electric motor forms an integral part of the machine.

C. Multi-motor Drive

- In this drive system, there are several drives, each of which serves to actuate one of the working parts of the driven mechanism.
- Applications of such a drive are found in complicated metal cutting machine tools, paper making machines, rolling mills, etc.

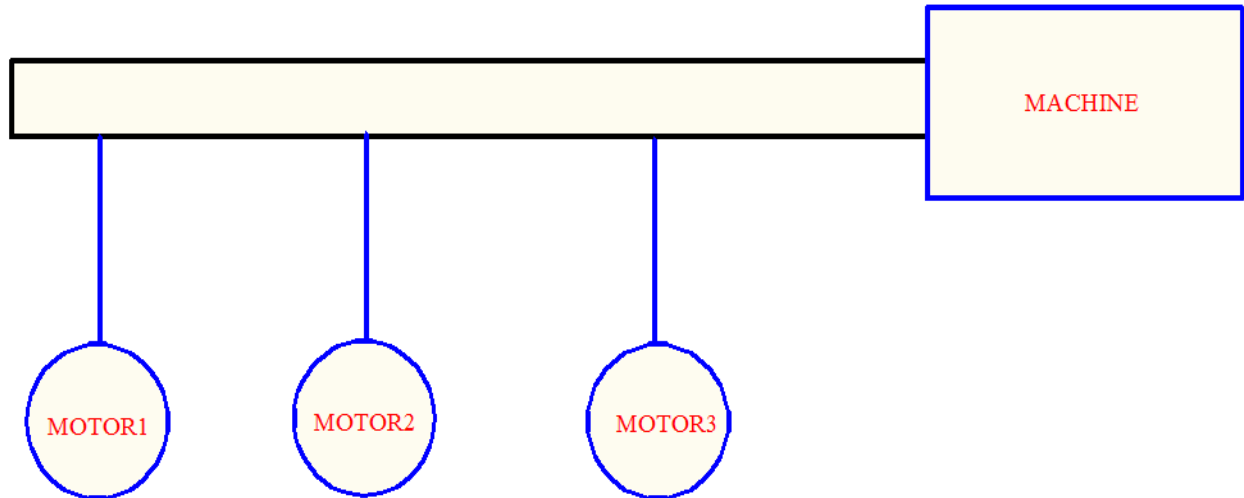

Fig.3.12 Multi-motor drive

- The drives of a crane can also be considered as an example of a multi-motor drive system.
- This type of multi-motor drive incorporates three drives:
 - o first for vertical movement
 - o second for side movement, and
 - o third for forward movement of the load.

3.5 BLOCK DIAGRAM OF VARIABLE FREQUENCY DRIVE (VFD)

- VFD is power electronics based device which converts a basic fixed frequency, fixed voltage sine wave power (line power) to a variable frequency, variable output voltage used to control speed of induction motor(s).

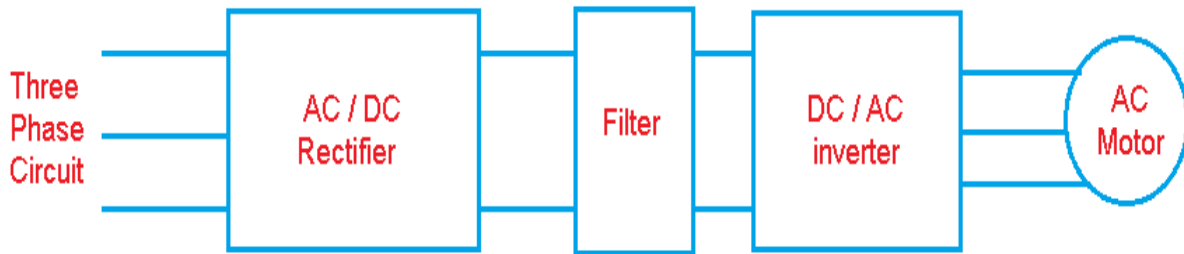

Fig.3.13 (a) Block diagram of Variable frequency drive

- It regulates the speed of a three phase induction motor by controlling the frequency and voltage of the power supplied to the motor.

$$N_s = \frac{120f}{p}$$

- Since the number of pole is constant the speed N_s can be varied by continuously changing frequency.

www.binils.com

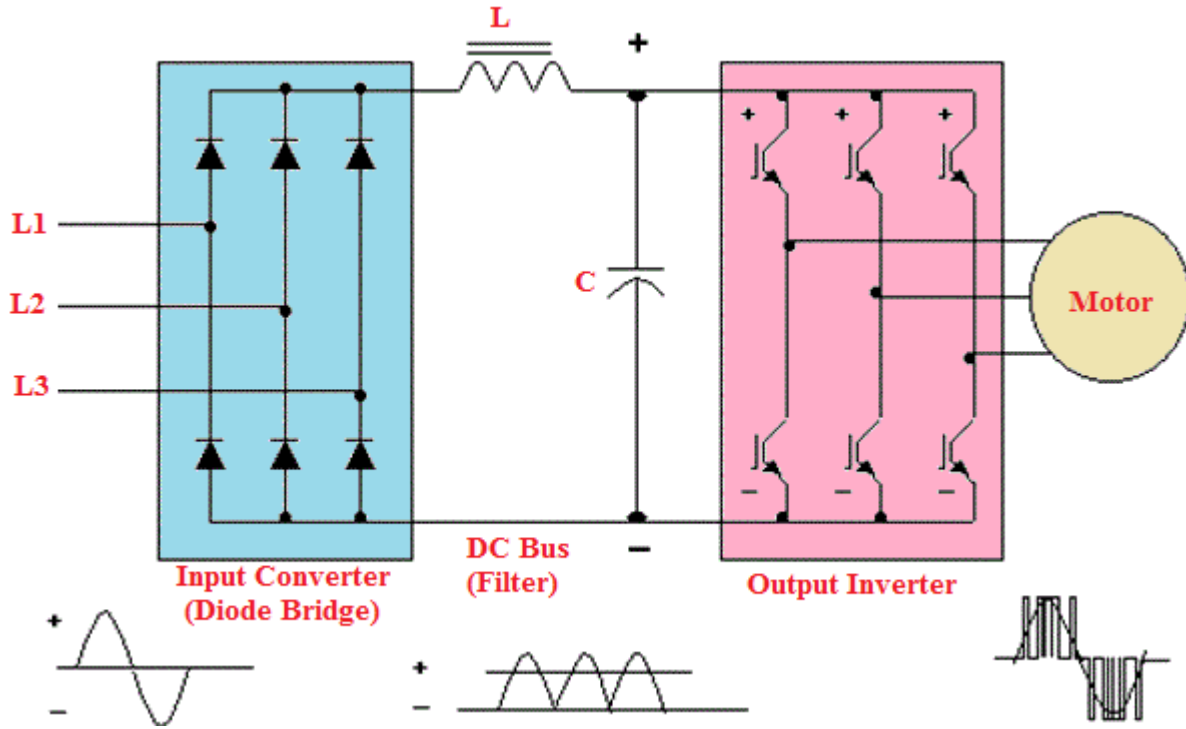

www.binils.com

Fig.3.13 (b) Circuit diagram of Variable frequency drive

3.6 STEPPER MOTOR DRIVE

- A **stepper motor drive** is a circuit which is used to drive or run a stepper motor.

3.6.1 Stepper motor drive full stepping

- Each control signal energizes one winding. The simplest way to control a stepper is to energize (fig.3.14) one winding at a time.

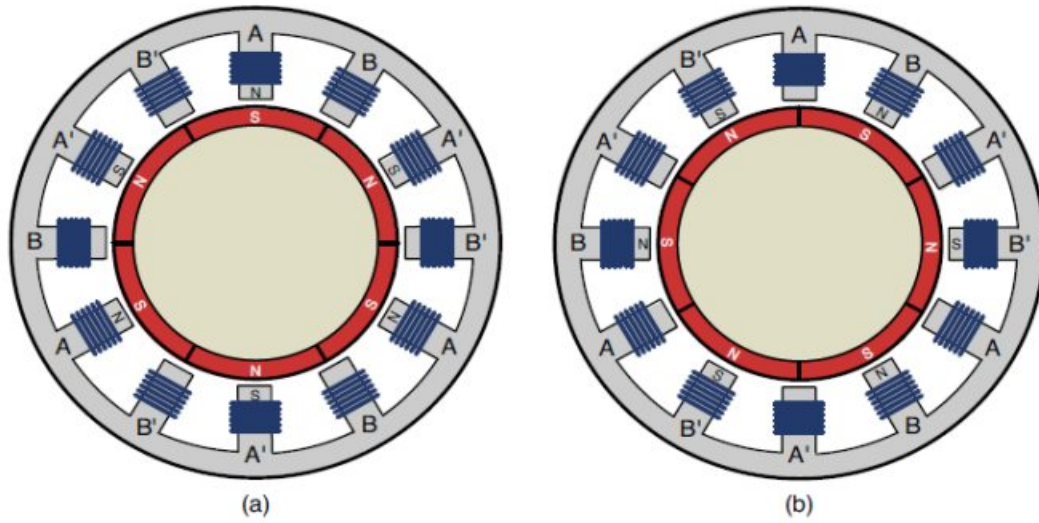

www.binils.com
 Fig 3.14 Stepper rotation in full step mode

- Figure 3.15 shows what the signaling sequence looks like when controlling a stepper in this mode.

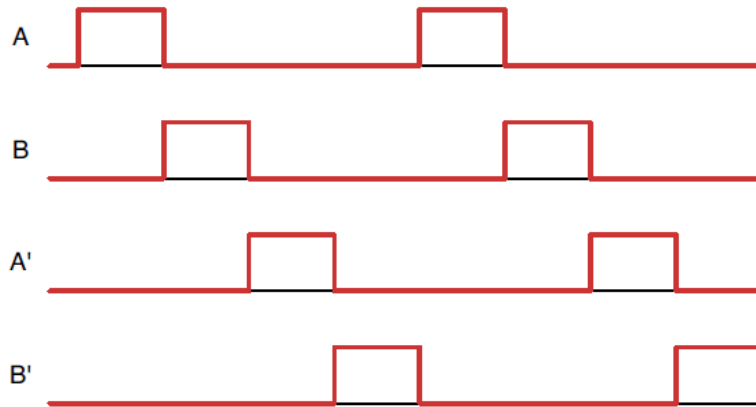

Fig.3.15 Drive sequence in full step mode

- With each control signal, the rotor turns to align itself with the energized winding. The rotor always turns through the stepper's rated step angle.
- That is, if a PM motor is rated for 30° , each control signal causes it to turn 30° .

3.6.2 Stepper motor drive half stepping

- The half-step mode is like a combination of the two full-step modes.
- That is, the controller alternates between energizing one winding and two windings. Figure 3.16 depicts three rotations of a stepper in half-step mode.

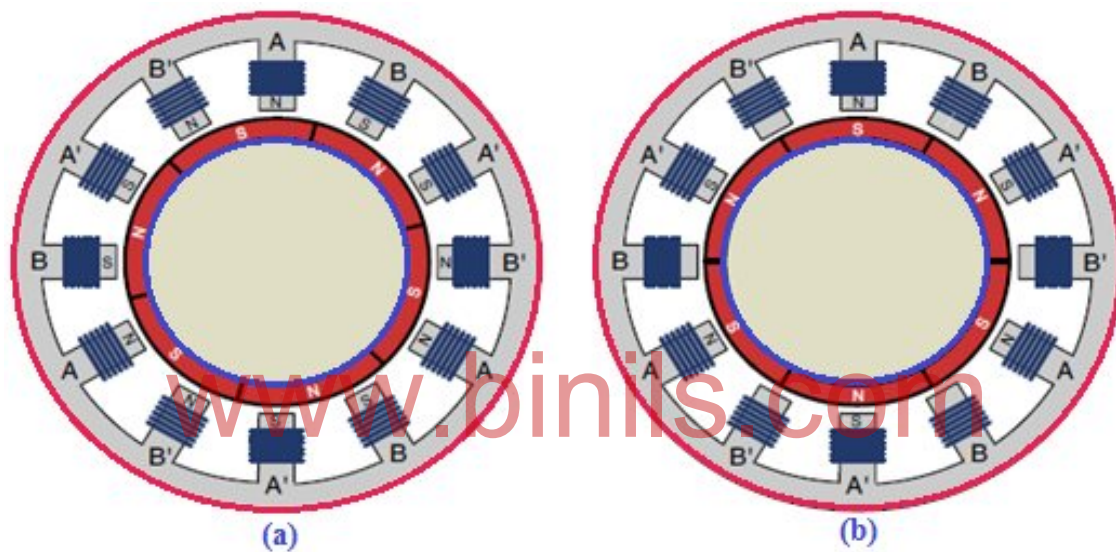
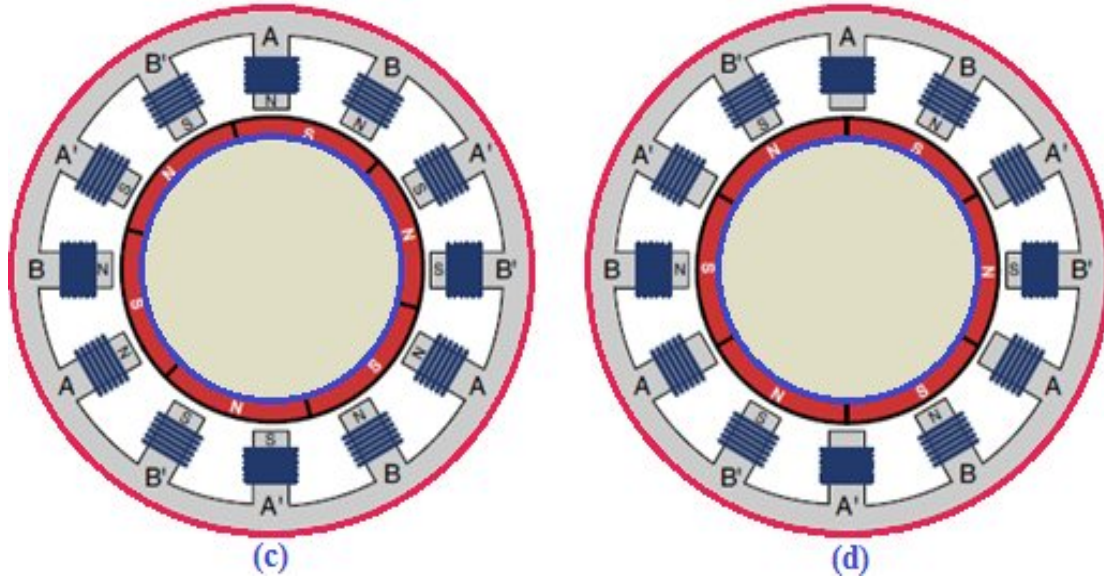

Fig.3.16 (a) & (b) Stepper rotation in half step mode

- Figure 3.17 illustrates a control signal for a stepper motor driven in half-step mode.
- In this mode, the rotor aligns itself with windings (when one winding is energized) and between windings (when two windings are energized).
- This effectively reduces the motor's step angle by half.



www.binils.com
 Fig.3.16(c) & (d) Stepper rotation in half step mode

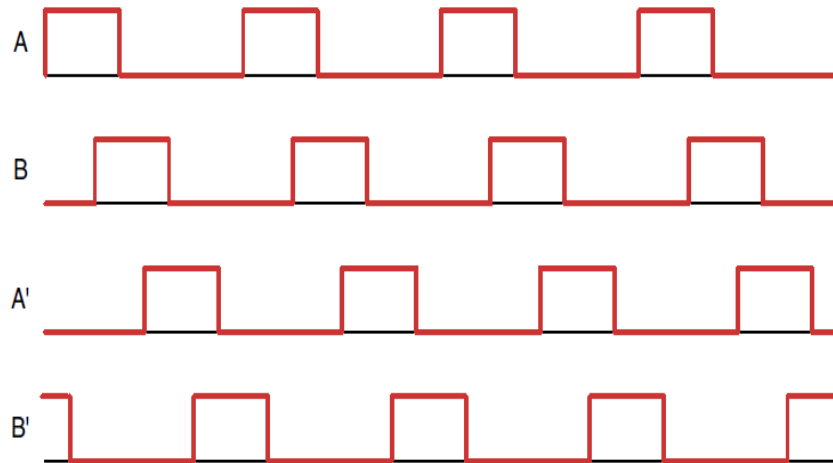

Fig.3.17 Drive sequence in half step mode

- That is, if the stepper's step angle is 1.8° , it will turn at 0.9° in half-step mode.
- The disadvantage of this mode is that, when a single winding is energized, the rotor turns with approximately 20% less torque. This can be compensated for by increasing the current.

3.6.3 Servo motor drives

- A servo motor may be a DC or AC or brushless DC motor combined with a sensor or position feedback system.
- These motors can be used as position control devices in a closed loop control system. This is done with the aid of a feedback device such as a position sensor.
- The feedback device converts the mechanical motion into electrical signals which is used as feedback.

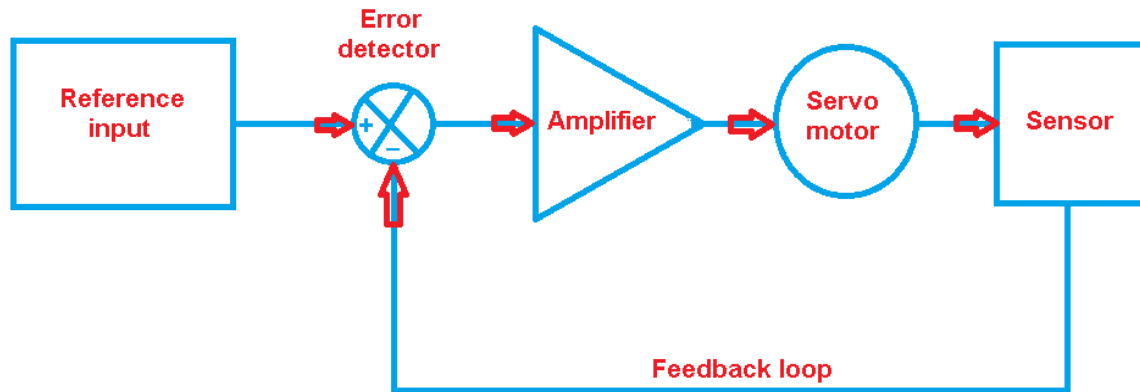

Fig.3.18 Block diagram of a typical servomotor drive.

- This feedback is sent to an error detector. If there is an error, it is fed directly to an amplifier, which makes necessary corrections.
- These motors can be used for speed, torque, and direction control applications. A typical construction of servomotor drive is shown in the figure3.18.

3.7 ELECTRICAL SAFETY:

3.7.1 Importance of Earthing

- The meaning of the term earthing or grounding is to connect the electrical equipment to the general mass of earth by wire of negligible resistance.
- This brings the body of the electrical equipment to zero potential and thus will avoid the shock to the operator.
- The neutral of the supply system is also solidly earthed to ensure its potential equal to zero.
- To save human life from shock. To protect large buildings from lightning.
- To protect all machines fed from overhead lines from lightning. To maintain the line voltage constant.
- To act as a return conductor for the telephone, telegraph and traction work.

3.7.2 Electric shock

- Human body has an electrical conducting property.
- Without sweating of human body the resistance is approximately 80000 Ohms and during sweating resistance of the human body is approximately 1000 Ohms.

- If we touch the current carrying conductor, the current is conducted through our body to earth.
- So the electrical circuit is closed and we get electric shock due to this, nervous structure, heart, lungs and brain are affected.
- If the current is heavy, death may occur. Therefore we must know, even though the current is essential, if it is used wrongly, it will cause heavy loss. i.e., death and economical loss.

3.7.3 First Aid

- Due to unavoidable reason, a man affects from sudden accident occur or electric shock, he may be treated by first aid method to protect from death, before taken into hospital.
- When a person is affected by current shock, first the circuit should be disconnected. If the main switch is nearer put off the switch or using any wooden stick we could disconnect the person from circuit. Then immediately send him to consult a doctor.
- If the affected person lose his consciousness, but breathing is normal then looser his clothes and apply cold water on his face and keep him open air.
- If the person does not breathe then immediately arrange artificial method of breathing clean his mouth and keep it open.

3.7.4 Precautions

It is always necessary to observe the following precautions against shock, since prevention is better than cure:

- Try to avoid on live mains which should be switched off before working.
- If it is not possible to switch the mains, be sure before working that your hands or feet are not wet and insulated with rubber shoes.
- In order to rescue a person who has got an electric shock if there is no other insulator available for rescuing, use your feet rather than hands, wearing the rubber shoes or P.V.C shoes.
- When working on high voltages, be sure that the floor is not conductor. Concrete floors are dangerously conductive.
- When working on high voltages, try to keep your left and in the pocket. i.e., avoid your left hand to get in contact with any live conductor or metallic causing of an apparatus or metal pole or cross arms.
- Do not work in such a place where your head is liable to touch the live mains before making the circuit dead.

3.7.5 Accident

Accident may be defined as an unplanned and unexpected event. It causes injury to the body or property.

3.7.6 Causes of Accident

- Poor condition of floor and ladder
- Improper earthing of machines
- Inadequate personal protective devices.
- Working on moving machinery
- Neglecting the safety rules. Lack of sufficient knowledge
- Environmental factors such as speed of work, work load, ventilation, illumination etc.
- Human factors such as age, health, work performance.

3.7.7 Preventive measures

- Before we use the equipments we must know the operation of that equipment. Electrical connections are made properly according to the definition.
- Only the trained and efficient person is allowed to operate, testing, repairing the machine.
- A person works in the electric post and tower post must wear the safety belt and gloves. After earthing the overhead lines by discharge rod, then the work will continue.
- Check the condition of all the hand tools, supply wires operated in current and also to check the earth wire is in good condition.
- To remove the plug point, pin from the socket by the proper way, cannot pulling the wire. All the hand tools used in electrical works must be insulated.
- During made up of wiring, switch is always connected in phase line.
- Sweating hand is not used to switch ON or work on the electric supply. If the person has sweating on the hand continuously, he must wear the gloves.
- If the switch is in OFF position, before to turn ON the switch to check if anybody is working in that electrical circuit.

3.7.9 Energy conservation

Energy conservation means using energy more efficiently or reducing wastage of energy. It is important that any energy conservation plan should only try to eliminate wastage of energy without affecting productivity and growth rate.

Need for energy conservation

Energy conservation is needed to reduce the wastage of energy. For household the main aim is to keep the monthly energy bills at the same level in case of increasing energy prices.

Possible benefits from energy conservations are: 1. Fuel savings 2. Less maintenance costs 3.Lesser pollution.

www.binils.com

REVIEW QUESTIONS

PART- A

1. State any two applications of permanent magnet DC motor?
2. State any two application of stepper motor?
3. State any two application of brushless servo motor?
4. State any two application of permanent magnet servo motor?
5. Write any one form for electric shock.
6. List the two types of servo motor.
7. Write one precaution of avoid electric shock.
8. Write any two methods of earthing .
9. Mention the different types of electrical drives
10. What is step angle?

PART-B

11. What is stepper motor?
12. What is individual drive.
13. What is group drive?
14. What is multi motor drive.
15. What is half stepping?

16. What is meant by earthing.
17. What is meant by energy conservation?
18. Draw the block diagram of variable frequency drive?
19. Write the important points of earthing?
20. Draw the block diagram of servo drives?

PART C

21. Explain the construction and working principle PMDC motor?
22. Explain the construction and working of stepper motor?
23. Explain the construction and application of brushless servo motor?
24. Explain the construction and application of permanent magnet servo motor?
25. Explain the working of different types of drives?
26. Draw the block diagram of variable frequency drive and explain its working?
27. Explain the working of single stepping stepper motor drive?
28. Explain the working of half stepping stepper motor drive?
29. Write about the causes of accident. How will you prevent them?
30. What is meant by industrial drives? List the types and explain any two in details.
31. Write the importance of earthing?

www.binils.com

UNIT IV

POWER SUPPLIES AND LOGIC GATES

4.1 DIODE

4.1.1 Construction

- A diode is a two terminal device. It allows the flow of electric current in only one direction.

- It consists of PN junction formed by the semiconductor material made of Germanium or silicon. The P and N type regions are named as anode and cathode respectively.
- The symbol and construction of a diode is shown in Fig. 4.1.
- The arrow head indicates the conventional direction of current flow when the diode is forward biased.

The forward current rating of diodes is given below.

Low current diodes – 100 mA.

Medium current diodes – 500 mA.

High current diodes – 1A to 100 A

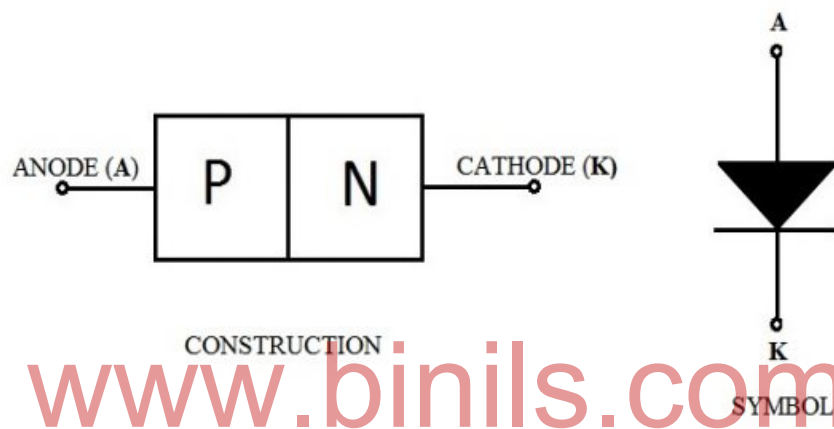

Fig. 4.1. Diode

N type semiconductor

In N type semiconductor, electrons are the majority carriers and holes are the minority carriers. N type semiconductor is obtained by adding pentavalent impurity to pure semiconductor. This pentavalent impurity donates free electron. Hence it is known as donor impurity.

P type semiconductor

P type semiconductor is obtained by adding trivalent impurity to a pure semiconductor. This impurity is called acceptor impurity which, create holes. Hence, in P type semiconductor holes are the majority carriers and electrons are the minority carriers.

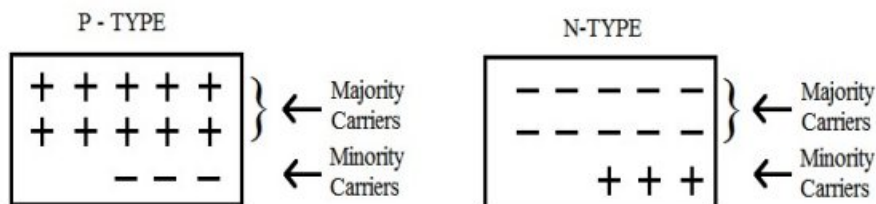

Fig.4.2. Charge carriers in P type and N type material

P-N JUNCTION

When a 'P' type semiconductor is joined with 'N' type semiconductor, PN junction is formed. The PN junction is fundamental to the operation of diodes, transistors and other solid state devices. When a PN Junction is formed, the following phenomenon takes place.

1. Formation of depletion layer
2. Development of barrier potential at the junction

Formation of depletion layer;

- P region has greater concentration of holes than N region. N region has greater concentration of electrons than P region. Due to this concentration differences, holes diffuse from P to N region and electrons diffuse from N to P region and terminate their existence by recombination.
- This recombination of free mobile electrons and holes produces the narrow region at the junction called depletion layer.
- The impurity atoms which provide these migratory electrons and holes become in an ionized state.
- As the holes are migrated, the acceptor impurity becomes the negative ion and as the electron are migrated, the donor impurity becomes the positive ion. These impurity ions are fixed in the P and N regions of the diode

Hence at PN Junction,

A row of fixed negative ions is produced by the migration of electrons from the N to P region.
A row of fixed positive ions is produced by the migration of holes from the P to N region.

The PN junction has immobile ions. This region is depletion of movable charge carrier.

Development of barrier potential:

Depletion layer has oppositely charged fixed rows of ions at two sides. Due to this charge separation an electric potential difference V_B is established across the junction. This potential is known as Barrier potential. It is denoted by V_B .

At room temperature of 30°C

V_B is 0.3 v for germanium (Ge) and 0.7 v for silicon (Si)

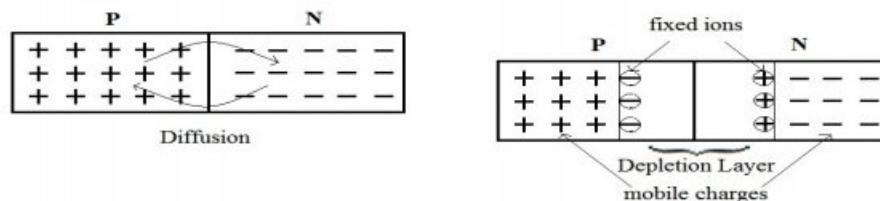

Fig.4.3 PN junction

This barrier potential sets up an electric field, which nullifies the diffusion of charge carrier from P region to N region and vice versa.

4.1.2 WORKING:

A P-N Junction diode is a unidirectional device. It conducts current when it is forward biased and the applied voltage is greater than its barrier potential. It prevents the flow of current when it is reverse biased. Hence such diodes are mostly used as rectifiers.

Biasing of a PN junction diode

The conduction of diode depends on the method of biasing. Applying a DC voltage of proper magnitude is known as biasing. There are two types of biasing.

1. Forward biasing
2. Reverse biasing

Forward biasing of PN Junction diode:

- When anode is given with positive supply and the cathode is given with negative supply, the diode is said to be forward biased.

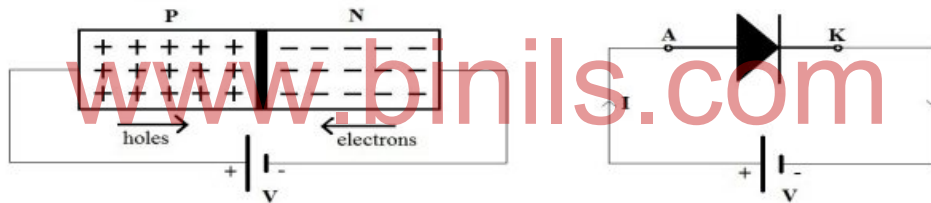

Fig.4.4 Forward biasing of PN junction

- When the battery connection is made as shown in the Fig. 4.4, holes are repelled by the positive battery terminal and electrons are repelled by the negative battery terminal. Hence electrons and holes move towards the junction.
- In the PN junction, the electrons and holes are recombined. As holes are driven towards the junction, more holes are created in P region. The electrons moving towards left are attracted by positive battery terminal. These electrons travel through the battery and enter to the negative terminal of battery and to the N region.
- These movements of electron and holes inside the semiconductor creates the anode current I_A . The forward anode current is in the order of mA or A.

Reverse basing of PN Junction diode:

- When cathode is given with positive supply and anode is given with negative supply, the diode is reverse based.

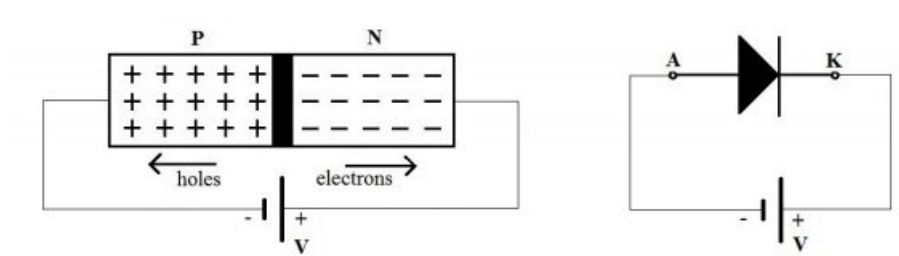

Fig.4.5. Reverse biasing of PN junction

- When the battery connection is made as shown in Fig.4.5., holes are attracted by the negative battery terminal and electrons are attracted by the positive battery terminal. Hence electrons and holes move away from the Junction. As there is no electrons hole recombination, there is no current flow due to majority carriers. The applied reverse voltage increases the barriers potential.
- But due to minority carriers, a small amount of reverse current called reverse saturation current (I_o) flows through the diode. The reverse saturation current is in the order of μA or nA .

4.1.3 VI characteristics:

1. Forward characteristics:

- When anode is connected to positive terminal of the battery and cathode is connected to negative terminal of the battery, the diode is forward based. When the applied voltage is gradually increased from 0V, no current flows through the device in the beginning. It is so because the applied voltage is opposed by the internal barrier voltage (0.3 V for Ge, 0.7 V for Si).
- When the applied voltage is greater than barrier voltage $V > V_B$, it neutralizes the effect of barrier voltage. Hence the forward current through diode increases rapidly with increasing applied voltage. The forward current is in the order of mA or A.
- If the forward voltage is increased above the safe limit, diode is burnt out.

2. Reverse characteristics:

- When anode is connected to negative terminal of the battery and cathode is connected to positive terminal of the battery, the diode is reverse biased.
- During reverse bias, the majority carriers are blocked. Hence no current flows through diode due to majority carriers.
- Only a small amount of reverse leakage current (I_o) flows through diode in the reverse direction due to minority carriers. The reverse leakage current is in the order of μA or nA . The value of I_o is independent of applied voltage. It depends on temperature of the PN junction.

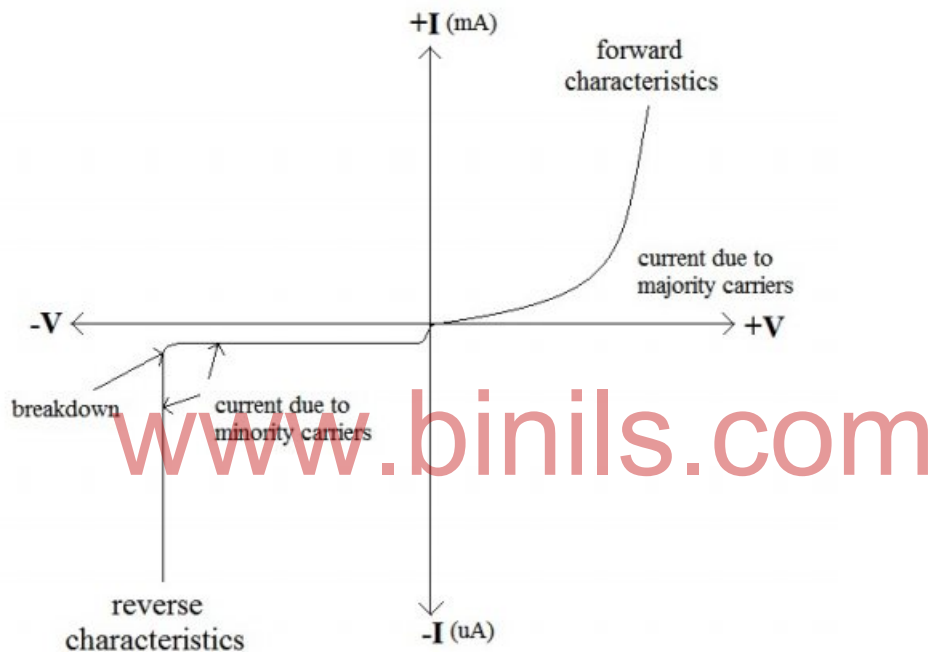

Fig. 4.6. VI Characteristics of diode

When reverse voltage exceeds a certain value called break down voltage (V_{BR}), the leakage current suddenly and sharply increases. If reverse voltage is increased further, diode is burnt out. The forward and reverse characteristics of diode is shown in Fig. 4.6.

4.1.4 Applications:

- Used in Rectifier circuits.
- Used in logic circuits and comparators.
- Used as Zener diodes in voltage stabilizing circuits.
- Used in communication circuits

4.2 RECTIFIERS

4.2.1 Introduction

Due to economy in generation and transmission, the electric power is usually available in A.C supply. The supply voltage varies sinusoidally and has a frequency of 50 HZ. The A.C supply is mostly used for heating, electric motors and industries. But there are many devices that works only with D.C supply.(ex. Electronic circuits). Rectifier is used to convert A.C supply to D.C supply. Rectifier is used in almost all the electronic devices mostly in the power supply section to convert the main voltage into DC voltage.

4.2.2 Use of diode in Rectifier

An electronic circuit that converts A.C supply in to D.C supply is known as rectifier. P.N junction diode is used in rectifier circuits.

Fig. 4.7. illustrates the use of diode in rectifier circuit.

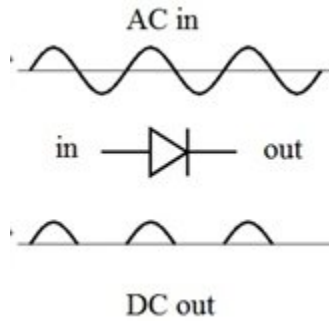

Fig. 4.7. Use of diode in rectifiers

The A.C input voltage (V_{in}), PN Junction diode (D) and load (R_L) are connected in series, as shown in Fig. 4.8. The output voltage (V_{out}) is available across the load R_L .

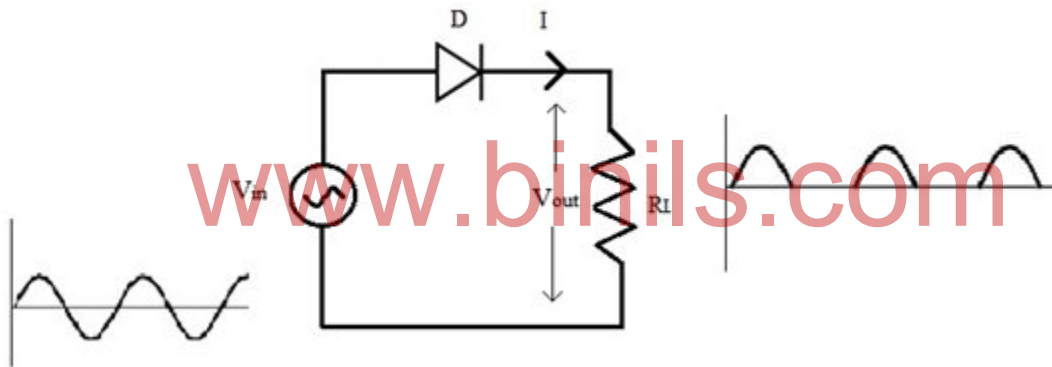

Fig. 4.8. Basic rectifier circuit

The PN junction diode is a unidirectional device. It conducts current only in forward direction.

During positive half cycle of the A.C input voltage, diode is forward biased. When the diode is forward biased, it acts like a closed switch. Hence the input A.C voltage is connected to the load R_L . During negative half cycle of the A.C input voltage, the diode is reverse biased. When the diode is reverse biased, it acts like an open switch. Hence the input A.C voltage is disconnected from the load R_L .

Hence the output voltage contains only positive half cycles of the input A.C voltage. In this way, the diode is used in rectifier circuits.

4.2.3 Types of Rectifiers

Based on the construction, the period of conduction and number of diodes used, rectifiers are classified in to following types.

1. Half wave rectifier
2. Full wave rectifier
3. Bridge rectifier

4.3 Half wave rectifier

A half wave rectifier is an electronic circuit that rectifies only half cycle of the input A.C waveform. It is a simple circuit and cost effective.

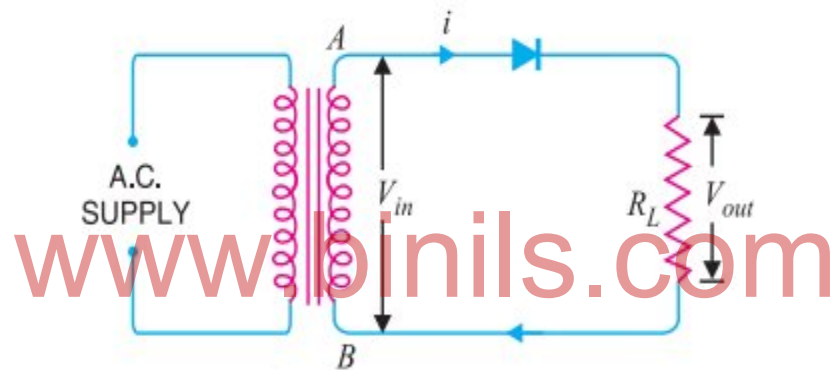

a) Circuit diagram

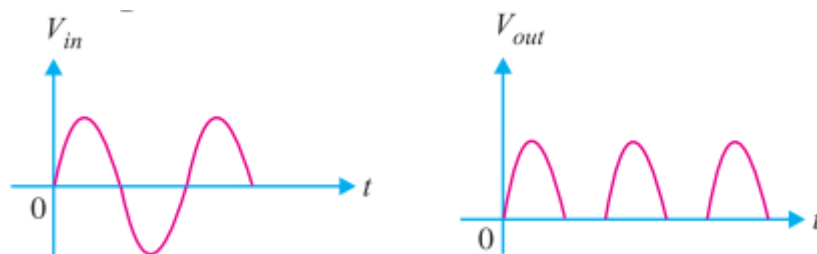

b)AC Input

c)DC Output

Fig. 4.8. Half wave rectifier

4.3.1 Circuit details

Fig. 4.8. shows the basic circuit of a half wave rectifier. It consists of a step down transformer, a diode D and a load resistance R_L which are connected in series. The A.C voltage to be rectified is applied to the input of the transformer primary winding. The transformer steps down the voltage. The step down voltage (V_{in}) which is available across secondary winding is applied to the diode and Load resistance R_L .

4.3.2 Operation

When an A.C voltage is applied to the input circuit, the A.C voltage across the secondary winding AB changes its polarity after every half cycle.

During positive half cycle:

Terminal A is positive with respect to terminal B . This makes, anode of the diode positive with respect to cathode. Hence the diode is forward biased and it conducts current. A current (i) flows through terminal A , diode and Load resistance R_L and terminal B . Now there is a voltage drop across load resistance R_L .

During negative half cycle:

Terminal A is negative with respect to terminal B . This makes, anode of the diode negative with respect to cathode. Hence the diode is reverse biased and it does not conduct current. Hence no voltage drop is available across load resistance R_L .

Hence, when an AC voltage is applied to the input of the rectifier, only for the positive half cycle current flows through the diode and load resistance. Hence the output voltage (V_{out}) across Load resistance R_L contains only positive half cycle. It is called as a pulsating DC voltage. The pulsations in the output voltages are smoothened by the filter circuits.

The input voltage, Output voltage and Load current wave forms are shown in the figure. Since only one half cycle of the input wave is used, it is called as a Half wave rectifier.

Advantages

1. Circuit is simple
2. Less cost

Disadvantages

1. To produce pure D.C voltage, it requires complicated filter circuit
2. The AC supply delivers power only half cycle. Therefore, the output power is low.
3. Rectification Efficiency is Low. (40.6% only).

4.4 FULL WAVE RECTIFIER

Full wave rectifier is an electronic circuit which converts A.C input voltage in to D.C output voltage using both half cycles of the A.C input voltage. The following two circuits are commonly used for full wave rectification.

1. Centre-tap full wave rectifier
2. Full wave bridge rectifier

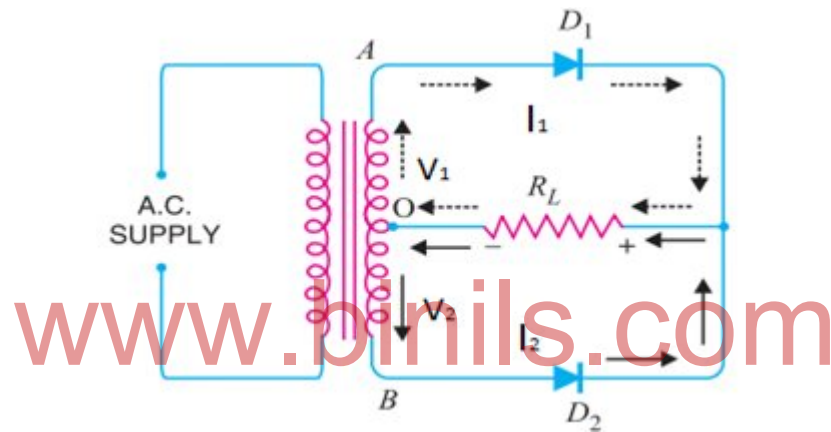
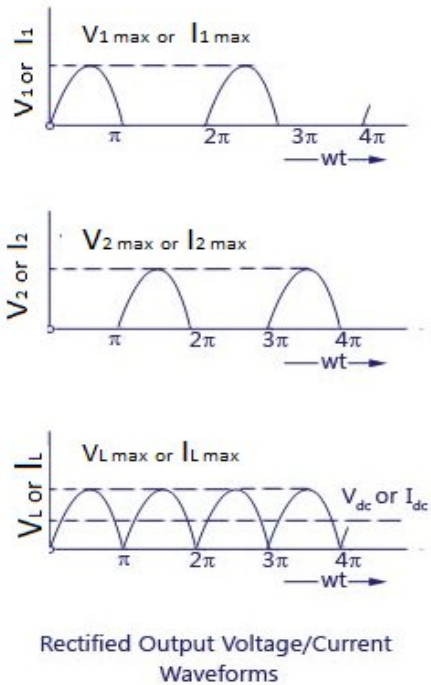

Fig. 4.9. a)Center-tap fullwave rectifier



www.binils.com

Fig. 4.9. b) Input and output waveform

4.4.1 Circuit details

- Fig. 4.9 a) shows the basic circuit of a full wave rectifier. It consists of a centre-tap transformer, two semiconductor diodes D1 and D2 and a load resistance R_L .
- The centre tap transformer has a single primary winding and the centre tapped secondary winding. The Secondary winding terminals are labelled as A and B and centre tap is labelled as O.
- The supply voltage to be rectified is applied to the transformer primary winding. The centre tapped secondary winding produces two voltages V_1 and V_2 across the terminals OA and OB respectively.

- The centre tap O is usually taken as Ground. Terminal A is connected to the Anode of Diode D1 and terminal B is connected to the anode of Diode D2. The load resistance is connected between cathode junctions of the diodes D1 and D2 and the terminal O.

4.4.2 Operation

- When an A.C voltage is applied to the input circuit, terminal A and B of the transformer secondary become positive and negative alternatively.

During positive half cycle of the AC input:

- Terminal A is positive, Terminal O is at zero potential and terminal B is at negative potential. This makes the anode of diode D1 is positive with respect to its cathode which is at zero potential and diode D1 is forward biased.
- The anode of Diode D2 is at negative with respect to its cathode and Diode D2 is reverse biased. Therefore, diode D1 conducts and diode D2 does not conduct. A current I_1 flows through terminal A, Diode D1 and load resistance R_L as shown in figure.

During negative half cycle of the AC input:

- Terminal A is negative, Terminal O is at zero potential and terminal B is at positive potential. This makes the anode of diode D1 is negative with respect to its cathode which is at zero potential and diode D1 is reverse biased.
- The anode of Diode D2 is at positive with respect to its cathode and Diode D2 is forward biased. Therefore, diode D2 conducts and diode D1 does not conduct. A current I_2 flows through terminal B, Diode D2 and load resistance R_L as shown in figure.
- Thus, when an A.C voltage is applied to the input of the rectifier, during positive half cycle of the input voltage diode D1 conducts the current I_1 and during negative half cycle diode D2 conducts the current I_2 .
- Further, current flows through the load resistance R_L in the same direction in both half cycles of A.C input. Hence a pulsating DC voltage is developed across the load resistance during both the half cycles as shown in figure. The input voltage, Output voltage and Load current wave forms are shown in figure.

Advantages

1. It produces higher output voltage than half wave rectifier.
2. It has higher rectification efficiency.

Disadvantages

1. Higher cost compared to half wave rectifier.

2. It requires centre tapped transformer.
3. The diodes used must have high peak inverse voltage.

4.5 FULL WAVE BRIDGE RECTIFIER

- Full wave bridge rectifier is an electronic circuit which converts A.C input voltage in to D.C output voltage using both half cycles of the A.C input voltage.
- It is the most frequently used circuit for electronic D.C power supplies. It requires 4 diodes but it does not require centre tapped transformer.

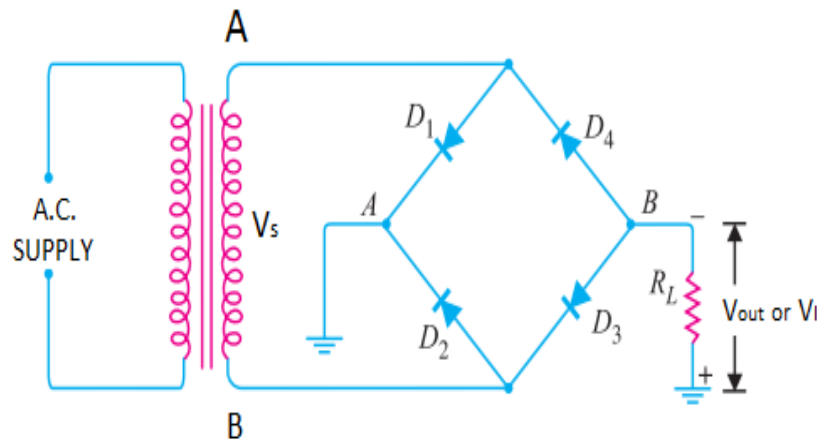

www.binils.com

Fig. 4.10 a) Circuit diagram of Bridge rectifier

4.5.1 Circuit details

- Fig. 4.10. a. shows the basic circuit of a bridge rectifier. It consists of step down transformer, four semiconductor diodes D_1, D_2, D_3 and D_4 connected to form a bridge and a load resistance R_L . The Secondary winding terminals are labelled as A and B.
- The supply voltage to be rectified is applied to the transformer primary winding. All the 4 diodes are connected in a bridge like arrangement.
- The A.C voltage is applied across the anode-cathode junctions of the bridge. The load resistance is connected across the anode junctions and cathode junctions.

4.5.2 Working

- When an A.C voltage is applied to the circuit, terminal A and B of the transformer secondary become positive and negative alternatively.

During positive half cycle of the AC input:

- Terminal A is positive with respect to terminal B. This makes the diodes D1 and D3 forward biased (ON) and the diodes D2 and D4 reverse biased (OFF). Hence current I_L flows through terminal A, diode D1, load resistance R_L , diode D3 and terminal B.

www.binils.com

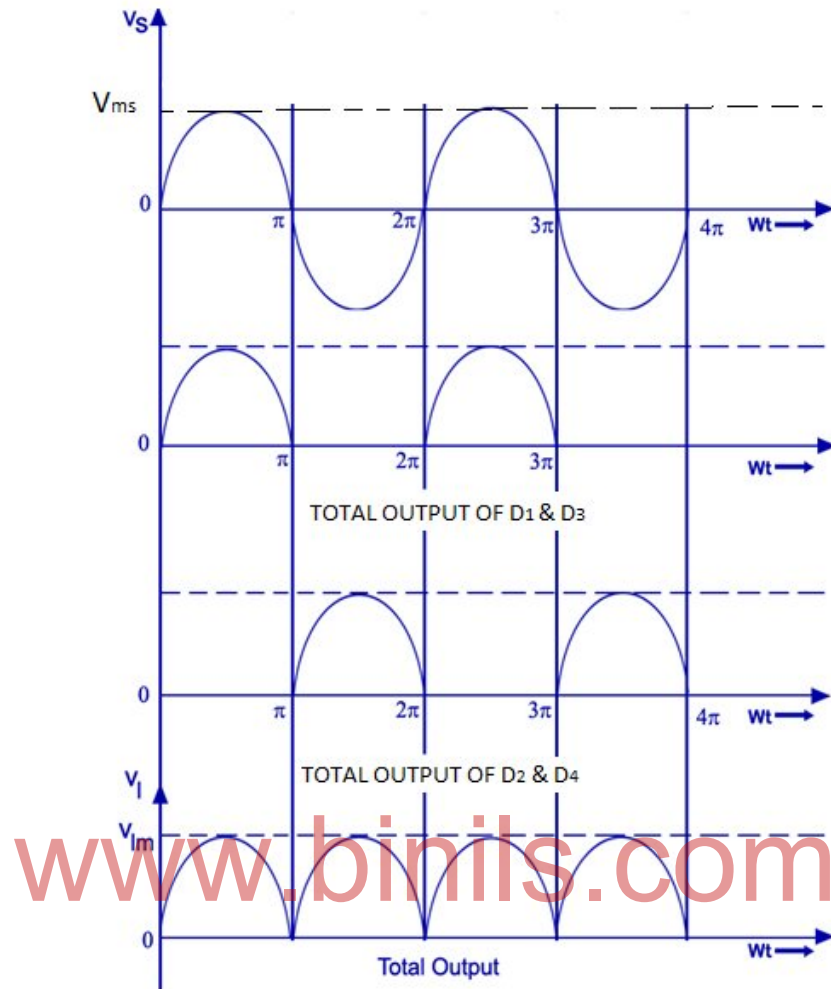

Fig. 4.10 b) Input and output waveform

During negative half cycle of the AC input:

- Terminal B is positive with respect to terminal A. This makes the diodes D2 and D4 forward biased (ON) and the diodes D1 and D3 reverse biased (OFF). Hence current I_L flows through terminal B, diode D2, load resistance R_L , diode D4 and terminal A.
- Thus, when an A.C voltage is applied to the input of the rectifier, during positive half cycle of the input voltage diode D1 and D3 conduct and during negative half cycle diode D2 and D4 conduct.
- However, the current flowing through the load resistance R_L is in the same direction during both half cycles of the A.C input voltage. Hence a pulsating DC voltage is developed across Load resistance R_L . The input and output voltage waveforms are shown in Fig. 4.10. b.

4.5.3 Advantages

1. No centre tap is required on the transformer
2. Much smaller transformers are required
3. It is suitable for high voltage applications
4. It has less PIV rating per diode.

4.5.4 Disadvantages

1. It requires 4 diodes

4.6 NECESSITY OF FILTERS

Rectifier is generally used in almost all the electronic devices in the power supply section to convert the main voltage into DC voltage. However, the output of the rectifiers is pulsating D.C voltage. The pulsating D.C voltage contains D.C components and A.C components. The presence of A.C components in the D.C voltage is undesirable. So it must be removed by filters. The filter circuit removes the unwanted A.C component of the rectifier output voltage. It allows only the D.C component of the output voltage to reach the load.

Filter circuit is connected between the rectifier and the load as shown in Fig. 4.11.

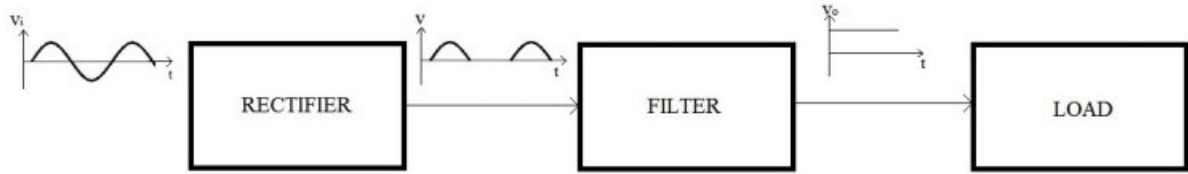

Fig. 4.11. Block diagram

Filter circuit contains a combination of inductors (L) and capacitors (C).

A capacitor passes A.C and blocks D.C. An inductor opposes A.C and passes D.C. Hence by suitably connecting inductor and capacitor the filter circuit is designed.

Types of filter circuits

1. Capacitor filter
2. Inductor filter
3. L-C filter
4. R-C filter
5. R-L-C filter

4.7 REGULATED POWER SUPPLIES

4.7.1 Introduction

All the electronic circuits require a D.C power supply. Batteries are generally not used for power supply as it is costly and requires frequent replacement. Usually D.C power for electronic circuits is obtained from available A.C lines by using Power supply circuits which contains rectifier and filters.

The D.C voltage from the ordinary power supply circuit is constant, if the value of

1. A.C Input voltage is constant.
2. Load is not changed.

However, there will be changes in input voltage and load values. These changes affect the output voltage of the power supply. In order to get the constant D.C output voltage Regulated power supply is used.

4.7.2 Regulated power supply

A D.C power supply which maintains the output voltage constant irrespective of the changes in input voltage and load variation is called as regulated D.C power supply. The block

diagram of regulated power supply is shown in Fig. 4.12. It contains transformer, rectifier, filter, voltage regulator and voltage divider.

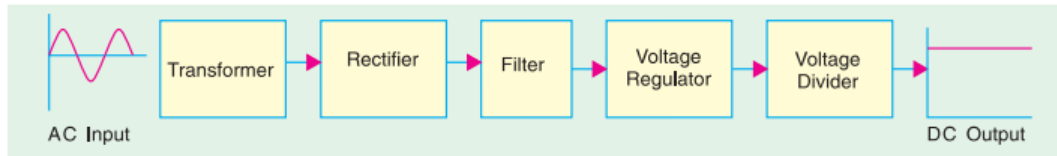

Fig. 4.12. Block diagram of Regulated power supply

1. Transformer

The voltage available in single phase A.C supply line is 230 V A.C. But the electronic circuits require D.C voltages of lower values. The transformer step-down the voltage from 230 V A.C to the low A.C voltage levels as required by the electronic circuits. It also provides isolation from the supply lines.

2. Rectifier

Rectifier converts the low voltage A.C supply in to pulsating D.C voltage. Rectifier circuit contains one or more diodes. The different types of rectifier are

- a. Half wave rectifier
- b. Full wave rectifier
- c. Bridge rectifier

3. Filter

The output voltage of the rectifier is pulsating D.C voltage. The pulsating D.C voltage contains A.C components in addition to D.C voltage. These unwanted AC components are called as ripples. The filter circuit removes the ripples present in the output signal of the rectifier. Hence the output of the filter is pure D.C voltage. The different types of filter used are

1. Capacitor filter
2. Inductor filter
3. L-C filter
4. R-C filter
5. R-L-C filter

4. Voltage Regulator

The voltage regulator maintains the terminal voltage of the D.C supply at constant value even when

- (i) A.C input voltage to the transformer varies or
- (ii) The load varies.

The different types of regulator used are

- a. Zener diode voltage regulator
- b. IC voltage regulator
- c. Transistor series voltage regulator
- d. Transistor shunt voltage regulator

5. Voltage divider

The voltage divider provides different D.C voltages needed by different electronic circuits. It consists of a number of resistors connected in series across the output terminals of the voltage regulator.

4.8 IC VOLTAGE REGULATOR

- Voltage regulator is an electronic control circuit which provides nearly a constant D.C output voltage even when there are variations in load or input voltage.
 - IC voltage regulators provides more constant DC output voltage compared to other types of voltage regulators.
 - Due to low fabrication cost, many IC voltage regulators are available in market with low price.
 - IC regulators have much improved performance than the voltage regulators made by discrete components. They have a number of unique built in features as below.
1. Current limiting
 2. Self-protection against over temperature
 3. Programmable output
 4. Current/ voltage boosting

The IC voltage regulators are classified in to following three types.

1. Linear regulator
 - a) Three terminal fixed voltage regulator (positive and negative output voltage)
 - b) Adjustable output voltage regulator (positive and negative output voltage)
 - c) Special regulators
2. Switching regulators.

4.8.1 Positive voltage regulator series

- Positive voltage regulators are available in 7800 series. They are three terminal positive voltage regulator with seven voltage options.
- These ICs are designed to produce fixed output voltage and can deliver currents in the order of 1 A.

Device type	Output voltage (V)
7805	5.0
7806	6.0
7808	8.0
7812	12.0
7815	15.0
7818	18.0
7824	24.0

7805 IC VOLTAGE REGULATOR

IC 7805 is a positive **Voltage Regulator** that maintains the voltage output to **+5V**. It comes with provision to add heatsink. The maximum of value input voltage to the voltage regulator is 35V. This voltage regulator provides a constant steady voltage of 5V. If the input voltage is nearer to 7.5V, then it does not produce any heat and hence heat sink is not necessary. If the voltage input is more, then excess heat is produced from the IC 7805. Hence heatsink is the necessary to dissipate the heat.

This regulator regulates a steady output of 5V if the input voltage is in range of 7.5 V to 35V. The circuit diagram of 7805 IC voltage regulator is shown in figure.

The un-regulated input voltage in the range of 7.5 V to 35V is applied between Pin no. 1 and 2. The input capacitor is connected between Pin No 1 and 2. The output capacitor is connected between pin no 3 and 2 where the regulated output voltage of 5 V is available. These capacitors are used to maintain constant DC output voltage and also act as filters.

This regulator is used in circuits where constant power supply voltage is required (e.g. Microcontroller power supply, power electronic circuits).

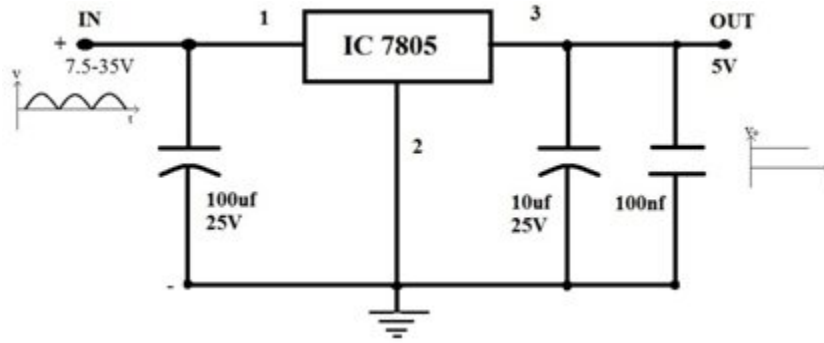

Fig. 4.13. 7805 Voltage regulator

4.8.2 Negative voltage regulator series

- Negative voltage regulators IC s are available in 79xx series. They are three terminal negative voltage regulator with seven voltage options.
- These ICs are designed to produce fixed negative output voltage and can deliver currents in the order of 1 A.

Device type	Output voltage (V)
7905	-5.0
7906	-6.0
7908	- 8.0
7912	-12.0
7915	-15.0
7918	-18.0
7924	-24.0

7905 IC voltage regulator

IC 7905 is a negative **Voltage Regulator** that maintains the voltage output to **-5V**. The circuit diagram is shown in fig. The capacitors connected at the input and output sides are used to maintain constant DC output voltage an also acts as filters.

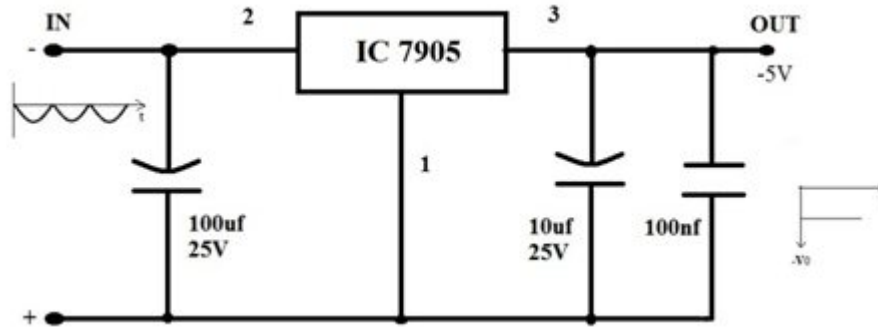

Fig. 4.14. 7805 Voltage regulator

4.8.3 Advantages of IC voltage regulators

1. They are easy to use
2. They Simplify the power supply design
3. Low cost
4. They are versatile.

4.8.4 Applications of IC voltage regulators

1. Used in Power supplies
2. Used in Amplifiers
3. Used in Digital to analog converters

4.9 SWITCHED-MODE POWER SUPPLY

Switched-mode power supply is known as switched power supply. Like a linear power supply, the switched mode power supply also converts the available unregulated ac or dc input voltage to a regulated dc output voltage. However, in case of SMPS, the input supply is drawn from the ac mains and the input voltage is first

rectified and filtered using a rectifier and capacitor filter. The unregulated dc voltage across the capacitor is then fed to a high frequency dc-to-dc converter.

High frequency DC-DC converter works on the chopper principle. Chopper is a circuit that converts fixed D.C voltage to variable D.C voltage.

$$V_o = k \times V_{in}$$

Where, V_o = output voltage of the chopper

V_{in} = input voltage of the chopper

k = duty cycle of the chopper

Duty cycle of the chopper $k = T_{on} / (T_{on} + T_{off})$

Where, T_{on} = On-time of the semiconductor switch

T_{off} = Off-time of the semiconductor switch

By varying T_{on} , the duty cycle of the chopper is varied. By varying duty cycle, the output voltage of the chopper is varied.

Most of the dc-to-dc converters used in SMPS circuits have an intermediate high frequency ac conversion stage to aid the use of a high frequency transformer for voltage scaling and isolation. The high frequency transformer used in a SMPS circuit is much smaller in size and weight compared to the low frequency transformer of the linear power supply circuit.

The block diagram of SMPS is shown in Fig. 4.15.

The SMPS converts the unregulated AC input voltage in to regulated DC output voltage.

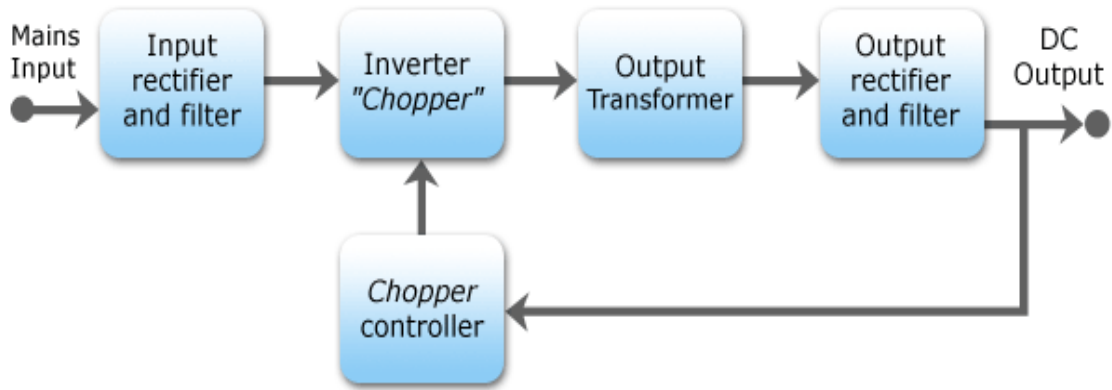

Fig. 4.15. Block diagram of SMPS

It consists of the following blocks.

1. Input rectifier and filter
2. Inverter/ Chopper
3. Output transformer
4. Output rectifier and filter
5. Chopper controller

1. Input rectifier and filter

The input rectifier converts the input 230 V A.C supply in to D.C voltage. The rectifier produces an unregulated DC voltage which is then sent to a large filter capacitor. The capacitor filter removes the ripples in the D.C voltage.

2. Inverter/ Chopper

The inverter /chopper circuit contains high frequency switches like MOSFET or BJT. The chopper converts the D.C voltage in to high frequency A.C wave. The frequency of high frequency A.C wave is above 20 KHZ. This high frequency switching is obtained in multi stage.

The input A.C voltage is rectified to DC by rectifier and the D.C voltage from rectifier is converter to high frequency AC by Inverter/Chopper. This high frequency switching has the following advantages.

1. The size of the output transformer is reduced. Hence the size of SMPS is compact.
2. Conversion efficiency is increased.

3. Output voltage can be regulated by duty cycle control.

3. Output transformer

The output transformer used in a SMPS operates with high frequency voltage. Hence the size and weight of the transformer is small compared to the low frequency transformer of the linear power supply circuit.

The output transformer is used for the following reasons.

1. To provide isolation between output voltage and input mains
2. For voltage scaling.

4. Output rectifier and filter

The high frequency A.C voltage from the output transformer is rectified using output rectifier. Output rectifier operates at high frequency voltage. The output of this rectifier contains high frequency ripples. These high frequency ripples can be easily filtered by smaller size filters.

5. Chopper controller

The chopper controller receives the feedback of D.C output voltage from the output rectifier. The fed back output voltage is compared with the reference voltage by comparator in chopper controller. Based on the difference of values between feedback voltage and reference voltage, the duty cycle of the chopper is continuously adjusted by chopper controller. When the load value is increased, the output voltage of SMPS is reduced. Hence the difference between feedback voltage and reference voltage is increased. The chopper controller increases the duty cycle of the chopper. Hence the output voltage of the SMPS is maintained as constant.

Advantages of SMPS

1. Greater efficiency.
2. Because of high frequency transformer, size of SMPS is small and less weight.
3. Less standby power loss.

Disadvantages of SMPS

1. Greater complexity
2. SMPS produces radio frequency interference and electromagnetic interference due to high frequency switching.
3. It introduces switching noise in the input power supply.

Applications of SMPS

1. Personal computers, Laptop
2. Mobile phone chargers
3. Printer and Fax machines

4. Automobile power supplies
5. Battery chargers
6. Consumer electronics like Television, VCR and CD players.

4.10 UN INTERRUPTED POWER SUPPLY (UPS)

There are several applications where even a temporary power failure can cause a greater economic loss and greater inconvenience. Examples of such applications are

1. Major computer installations
2. chemical plants
3. communication systems
4. Hospitals

For such critical loads, UPS provides emergency power when the input power source or mains power fails. The function of UPS is to maintain continuity of power to these critical loads.

In earlier days rotating type UPS was used. At present static UPS are popular. Static UPS systems are classified into two types.

1. Off line UPS
2. Online UPS

In off line UPS, load gets disconnected from the power supply for a short duration of 4 to 5 msec. In online UPS, load is not disconnected from the power supply.

4.10.1 Off line UPS

For certain type of loads short interruption of power is acceptable. Offline UPS is used for supplying power to these loads.

The block diagram of Offline UPS is shown in Fig.4.16.

In this system, main A.C supply is converted into D.C supply by using rectifier. The D.C output from the rectifier charges the battery. At the same time the D.C voltage is converted into AC voltage by an inverter. The A.C voltage is passed through the filter. The A.C voltage is delivered to the load in case normally off contacts are closed.

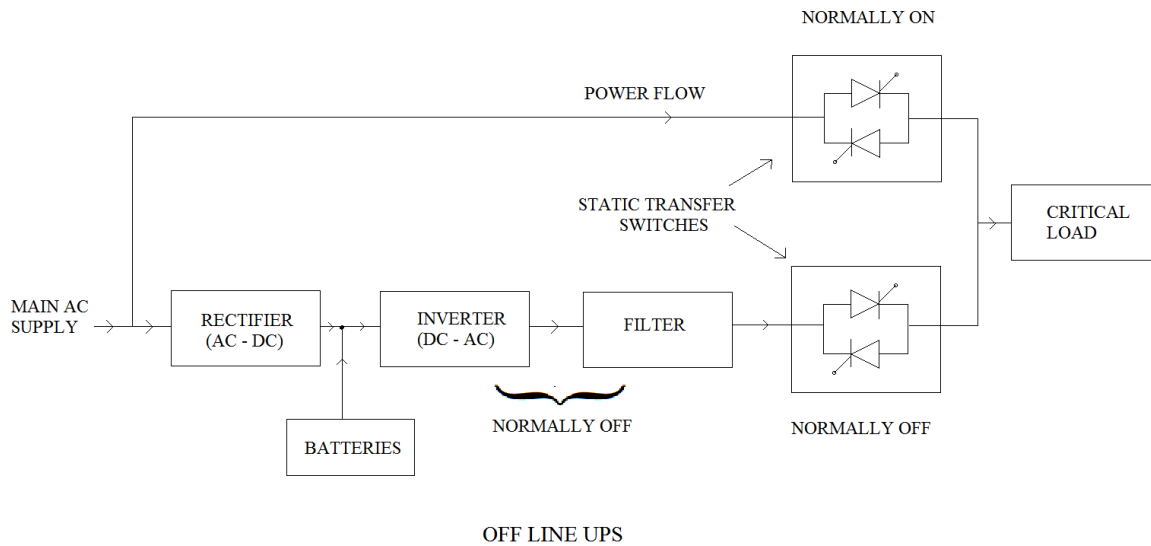

www.binils.com
Fig. 4.16. Block diagram of Off line UPS

Under normal circumstances, when the main A.C supply is available, the normally On contacts are closed and normally Off contacts are opened. Now the mains supply delivers power to the load through normally On contacts. At the same time, the D.C output voltage of the rectifier charges the battery. The battery stores the standby power.

If the main A.C supply fails, normally On contacts are opened and normally off contacts are closed. Now the battery delivers A.C power to load through inverter and filter. During change over from mains power to Battery power (standby power), momentary interruption of power is observed in load like fluorescent tube light.

When the A.C mains supply is restored, normally On contacts are closed and normally off contacts are opened. Now the main A.C supply delivers power to load through normally on contacts. During change over from standby power to mains power again momentary interruption of power is observed in load.

4.10.2 On line UPS

Online UPS is used for loads, where even short interruption of power is not acceptable. The block diagram of online UPS is shown in Fig.4.17.

In this system, main A.C supply is converted in to D.C supply by using rectifier. The D.C output from the rectifier charges the battery. Rectifier also supplies power to inverter continuously. The A.C output of the inverter is passed through filter and given to load through normally on contacts.

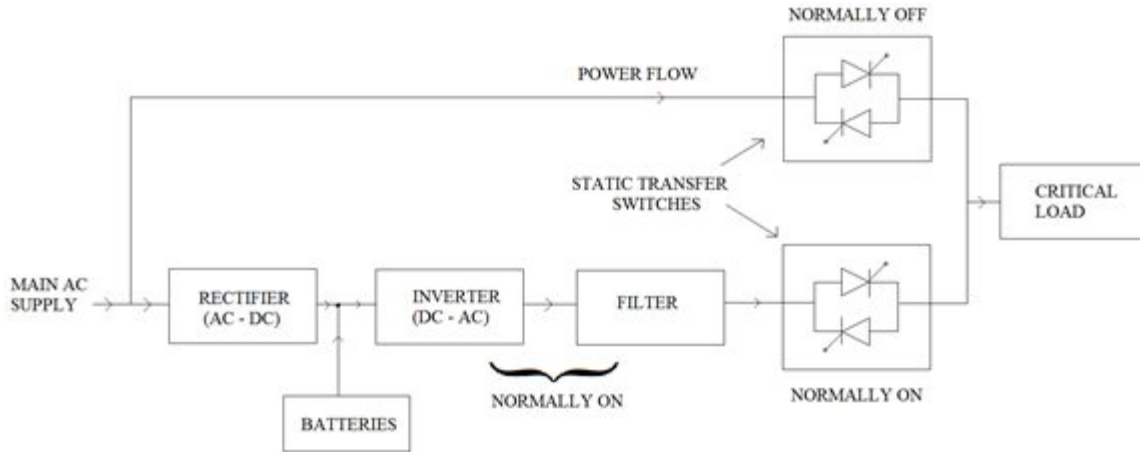

www.binils.com

Fig. 4.17. Block diagram of On line UPS

Under normal circumstances, when the main A.C supply is available, the normally On contacts are closed and normally Off contacts are opened. Now the mains supply delivers power to the load through normally On contacts. At the same time, the D.C output voltage of the rectifier charges the battery. The battery stores the standby power.

If the main A.C supply fails, battery provides D.C input power to the inverter. Hence no dip or no interruption of power is observed at the load.

In case of inverter failure, normally On contacts are opened and normally off contacts are closed. Now the main A.C supply delivers power to the load directly without using inverter.

Advantages of On line UPS.

1. The inverter can be used to condition the power deliver to the load.
2. Load is protected from supply voltage transients.

3. Inverter output frequency can be maintained as constant.

Application of UPS

UPS is used to provide an uninterrupted power to critical loads such as

1. Major computer installations
2. chemical plants
3. communication systems
4. Hospitals.

3.11. INVERTERS

Introduction

Inverter is a device that converts DC power in to AC power. It is used to convert the DC input voltage in to AC output voltage at the desired magnitude and frequency. The output voltage of an ideal inverter should be sinusoidal. But practical inverters produce non sinusoidal wave form in the output voltage. By using additional wave shaping circuits, pure sine wave is produced at the output.

By the method of connection of semiconductor devices, inverters are classified in to following types.

1. Series inverter
2. Parallel inverter
3. Bridge inverter

4.11.1 Single phase half bridge inverter

The circuit diagram of single phase half bridge inverter is shown in Fig.4.18.

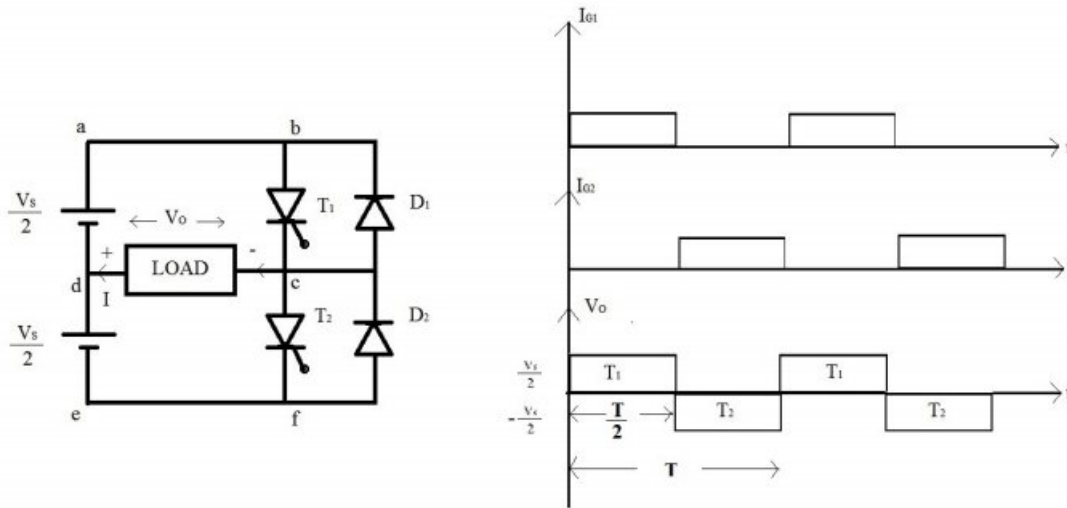

Fig. 4.18. Circuit diagram and wave form of Single phase Half bridge inverter
It consists of two SCRs, two diodes and three wire D.C supply. The wave forms are shown in Fig.4.18.

During the time $0 < t < T/2$

Gate pulse is applied to SCR T1. Hence SCR T1 is turned on. Now, current flows through (a b c d) the positive terminal of top battery, SCR T1, Load and negative terminal of top battery. The current flows through the load creates positive voltage drop of $V_s/2$ across load.

During the time $T/2 < t < T$

Gate pulse is applied to SCR T2. Hence SCR T2 is turned on. Now, current flows through (d c e f) the positive terminal of bottom battery, Load, SCR T2 and negative terminal of bottom battery. The current flows through the load creates negative voltage drop of $-V_s/2$ across load.

The diode D1 and D2 provides the path for current flow, if the load is of inductive nature. From the wave form it is seen that load voltage is an alternating voltage with amplitude of $V_s/2$ and frequency of $1/T$ Hz. The frequency of the output voltage can be varied by varying the time period T.

Application of Inverters

1. Used in UPS
2. Used in Electric motor speed control
3. Used in Induction heating
4. Used in HVDC transmission
5. Used in solar system

4.12 DISPLAY DEVICES

Display devices are the output device for presentation of information in visual or tactile form. When the input information is supplied as an electrical signal, the display is called an electronic display. Some display units are discussed below.

4.12.1 LIGHT EMITTING DIODE (LED)

Construction

The construction and symbol of LED is shown in Fig. 4.19. In this diode, an N type layer is grown on a substrate. P type layer is deposited on N type layer by diffusion process. The metal anode connections are made at the outer edge of P layer. A metal film is applied to the bottom of the substrate for reflecting more visible light. Cathode connection is made to the metal film. LED is always encased, in order to protect the wires.

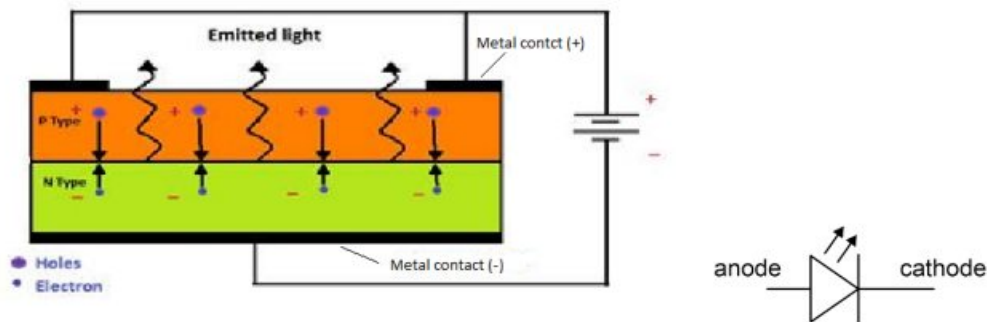

Fig. 4.19. a) Construction

Fig. 4.19. b) symbol

Theory

It is a forward biased PN junction diode which emits visible light when energized. During forward biasing of PN junction, recombination of charge carrier takes place. During recombination, the electrons lying in the conduction band of N region move towards the holes lying in the valance band of P region. Due to this movement, the energy difference between conduction band electrons and valance band holes is dissipated in the form of light and heat. For semiconductor material of Si and Ge, more heat is dissipated than light. For semiconductor material like gallium arsenide, gallium phosphide, and gallium arsenic phosphide, more light is dissipated than heat. If the semiconductor material is transparent, light is emitted at the junction. The colour of the emitted light depends on the type of material as given below.

1. Ga As – infra red (invisible)
2. Ga P- red or green light
3. Ga As P – red or yellow light.

LED emits no light, when it is reverse biased.

Applications

1. Used in burglar alarms
2. Used in televisions
3. Used in advertisement boards
4. Used in pocket calculators
5. Used in optical communication

4.12.2 SEVEN SEGMENT LED

The Fig. 4.20.b. shows the structure of seven segment LED display. It contains seven rectangular LED which can form digit 0 to 9. The seven segment LEDs are labelled a to g. Each LED is called a segment because it forms a part of the character being displayed. There are two possible connections in Seven segment LED display.

1. common anode connection
2. common cathode connection

Common anode connection

The schematic diagram of common cathode connection is shown in Fig.4.20.

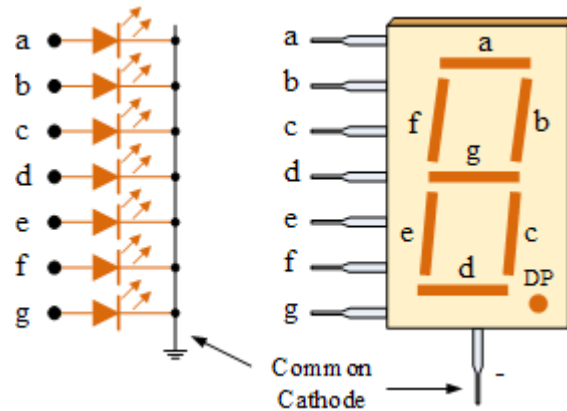

Fig. 4.20. a) Common cathode connection b) Structure of 7 segment LED

In the common cathode display, all the cathode connections of the LED segments are joined together and connected to ground. The individual segments are illuminated by application of positive voltage (+ 5 V) through a current limiting resistor to forward bias the individual Anode terminals (a to g).

The schematic diagram of common cathode connection is shown in Fig.4.21.a.

In the common anode display, all the anode connections of the LED segments are joined together and connected to positive voltage (+ 5 V). The individual segments are illuminated by applying a ground, through a suitable current limiting resistor to the Cathode of the particular segment (a to g). In general, common anode displays are more popular as many logic circuits can sink more current than they can source.

Depending upon the decimal digit to be displayed, the particular set of LEDs is forward biased. For example, to display the numerical digit 0, the LED segments a, b, c, d, e and f are forward biased by supplying + 5 Volt to these segments.

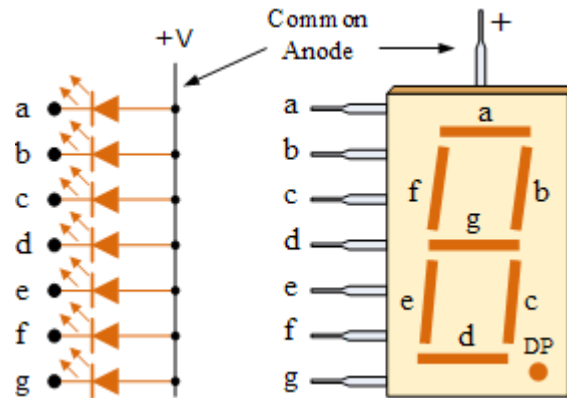

Fig. 4.21. a) Common anode connection b) Structure of 7 segment LED

Generally, the seven segment LED is driven by decoders or code converters. Common anode connection requires active low configuration for the code converter circuits. Common cathode connection requires active high configuration for the code converter circuits. The terminals a to g are connected to the output of the code converter circuits. The value of the current flowing through the chosen LED is set by a proper choice of series resistor R.

2.11.3. LIQUID CRYSTAL DISPLAY (LCD)

LCD display is actually a combination of two states of matter – the solid and the liquid. They have both the properties of solids and liquids and maintain their respective states with respect to another. Solids usually maintain their state unlike liquids who change their orientation and move everywhere in the particular liquid.

Construction

A liquid crystal cell consists of a thin layer (about 10 μ m) of a liquid crystal sandwiched between two glass sheets with transparent electrodes deposited on their inside faces. With both glass sheets transparent, the cell is known as *transmittive type cell*. When one glass is transparent and the other has a reflective coating, the cell is called *reflective type*. The LCD does not produce any illumination of its own. It, in fact, depends entirely on illumination falling on it from an external source for its visual effect.

Working

Two types of display available are

1. dynamic scattering display
2. field effect display.

When dynamic scattering displays are energized, the molecules of the energized area of the display become turbulent and scatter light in all directions. Consequently, the activated areas take on a frosted glass appearance resulting in a silver display. Of course, the unenergized areas remain translucent.

Field effect LCD contains front and back polarizers at right angles to each other. Without electrical excitation, the light coming through the front polarizer is rotated 90° in the fluid.

The mostly used liquid crystal for the industrial purpose is nematic phase liquid crystals.

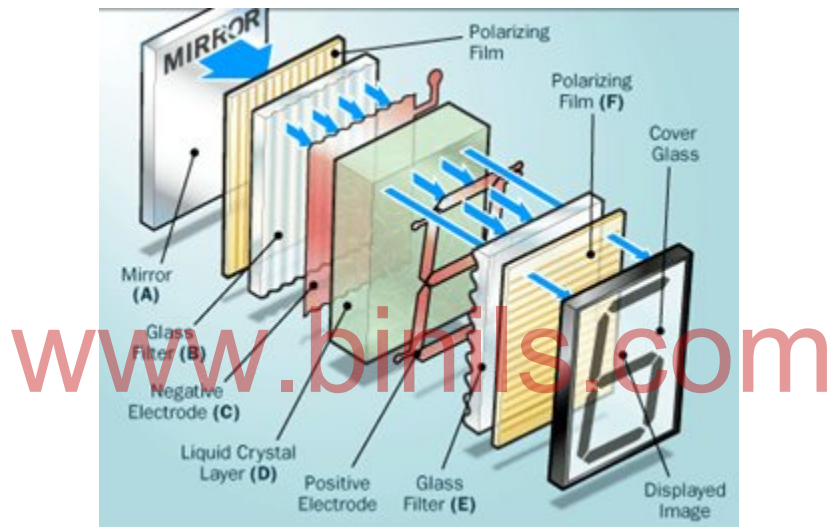

Fig. 4.22. Construction of LCD display

The main principle behind liquid crystal molecules is that when an electric current is applied to them, they tend to untwist. This causes a change in the light angle passing through them. This causes a change in the angle of the top polarizing filter with respect to it. So little light is allowed to pass through that particular area of LCD. Thus that area becomes darker comparing to others.

LCD screen, has a reflective mirror setup in the back side. An electrode plane made of indium-tin oxide is kept on top and a glass with a polarizing film is also added on the bottom side. The entire area of the LCD is covered by a common electrode and the liquid crystal substance is placed above. Another piece of glass with an electrode in the shape of the rectangle is placed on the bottom and, on top. It is noted that both of them are kept at right angles.

When there is no current, the light passes through the front of the LCD it will be reflected by the mirror and bounced back. As the electrode is connected to a temporary battery the current from it will cause the liquid crystals between the common-plane electrode and the electrode shaped like a rectangle to

untwist. Thus the light is blocked from passing through. Thus that particular rectangular area appears blank.

Advantages

1. Small in size and weight
2. Consume low power
3. Low cost
4. Good contrast

Applications

1. Used in watches, pocket calculators.
2. Used in laptop, computers.
3. Used in television displays.
4. Used in video games.
5. Used in instrument displays.

4.13 LOGIC GATES

Introduction

Digital circuits operate on binary signals. The binary signal contains only two voltage levels. Most of the digital system has the low voltage level of 0 V and high voltage level of 5 V. They are represented by binary numbers 0 and 1. Most of the digital systems are built up using logic gates.

Definition

A logic gate is an electronic circuit which makes logical decisions. It has one or more inputs and one output. The output signal appears only for certain combinations of input signals.

Logic gates are used to implement Boolean function.

4.13.1 Positive Logic and Negative logic

Digital system works on binary numbers. The binary numbers 0 and 1 represents two voltage levels.

- **In positive logic,**

The more positive voltage of the two voltage level represents the number 1 and the more negative voltage represents the number 0.

ie . +5 V D.C represents logic 1

0 V D.C represents logic 0.

Majority of the digital system works in positive logic.

- **In negative logic,**

The more negative voltage of the two voltage level represents the number 1 and the more positive voltage represents the number 0.

ie . +5 V D.C represents logic 0 and 0 V D.C represents logic 1.

The representation of positive logic and negative logic is shown in the fig.

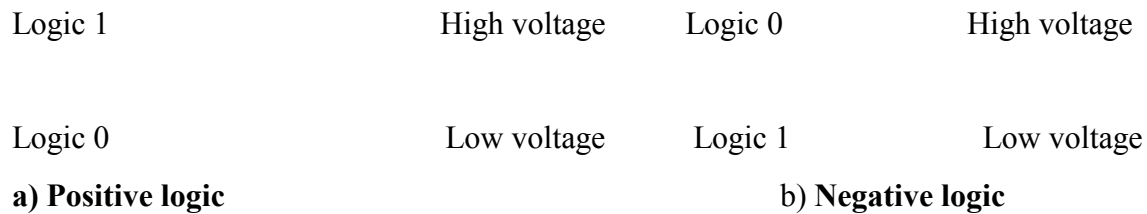

Fig.4.23. Positive and negative logic

The different types of gates are detailed below. There are seven basic logic gates: AND, OR, NOT, NAND, NOR, EXOR and EXNOR.

a) AND gate

The AND gate has two or more input signals and one output signal.

- Logic operation

AND gate gives a **high** output (1) only if **all** its inputs are high. It is known as **all or nothing** gate because the output is high only if all the inputs are high.

The symbol of two input AND gate and truth table is shown in the fig. The inputs are labeled as A and B. The output is labeled as Y. The output Y is 1, if the inputs both A and B are 1.

- The Boolean equation of AND gate is $Y = A.B$

A dot (.) is used to show the AND operation i.e. A.B.

Inputs		Output
A	B	$Y = A.B$
0	0	0
0	1	0
1	0	0
1	1	1

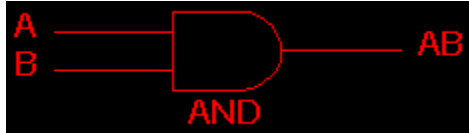

a)Symbol

b)Truth table

b) OR gate

The OR gate has two or more input signals and one output signal.

- Logic operation

OR gate gives a **high** output (1), when any one of its input is high. It is known as **any-or-all gate** because the output is high when any one of its input or all inputs are high.

The symbol of two input OR gate and truth table is shown in the fig. The inputs are labeled as A and B. The output is labeled as Y. The output Y is 1, when any of the input A, B or all of the inputs both A and B are 1.

- The Boolean equation of OR gate is $Y = A + B$
A plus (+) is used to show the OR operation.

Inputs		Output
A	B	$Y = A + B$
0	0	0
0	1	1
1	0	1
1	1	1

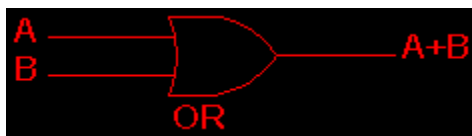

a)Symbol

b) Truth table

c) NOT gate

The NOT gate has one input signal and one output signal. It is so called because the output is NOT the same as input.

- Logic operation

The NOT gate gives the output with an inverted version of the input. It is also known as an *inverter*.

The symbol of NOT gate and truth table is shown in the fig. A bubble is marked at the output of all complement gates. It represents the complement function. The input is labeled as A and the output Y is the inversion or complement of input A. ie. If the input A is 0, the output Y is 1 and if the input A is 1, the output Y is 0.

- The Boolean equation of NOT gate is $Y = \bar{A}$

Input	Output
A	$Y = \bar{A}$
0	1
1	0

A bar over the top is used to show the NOT operation

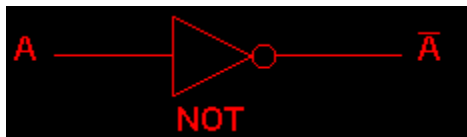

a) Symbol

b) Truth table

c) NAND gate

The NAND gate has two or more input signals and one output signal. NAND gate is a complement of AND gate. It is obtained by connecting a NOT gate in the output of an AND gate as shown in Fig.4.24.

A A.B

$Y = \overline{A.B}$

B

Fig.4.24.

- Logic operation

The output of NAND gates is high if any of the inputs are low. The symbol is an AND gate with a small circle on the output. The small circle represents inversion.

The symbol of two input NAND gate and truth table is shown in the fig. The inputs are labelled as A and B. The output is labelled as Y. The output Y is 1, if either A or B or both inputs are 0.

- The Boolean equation of AND gate is $Y = A.B$

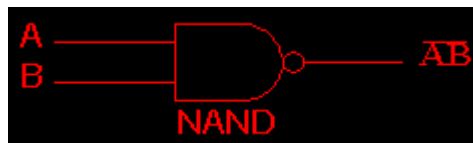

a)Symbol

Inputs		Output
A	B	$Y = A.B$
0	0	1
0	1	1
1	0	1
1	1	0

b)Truth table

d) NOR gate

The NOR gate has two or more input signals and one output signal. NOR gate is a complement of OR gate. It is obtained by connecting a NOT gate in the output of an OR gate as shown in fig.

- Logic operation

The output of NOR gates is high only when all its input are low. If any of input is high, output is low.

The symbol of NOR gate is an OR gate with a small circle on the output. The small circle represents inversion. The symbol of two input NOR gate and truth table is shown in the fig. The inputs are labelled as A and B. The output is labelled as Y. The output Y is 1, if both inputs are 0.

- The Boolean equation of NOR gate is $Y = \overline{A+B}$

Inputs		Output
A	B	$Y = \overline{A+B}$
0	0	1
0	1	0
1	0	0
1	1	0

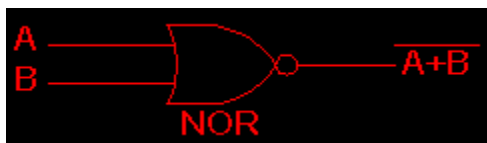

a) Symbol

b) Truth table

e) EXOR gate

The EXOR gate contains two or more inputs and only one output.

- Logic operation

The EXOR gate gives a high output when both the inputs are different.

The EXOR gate gives a low output when both the inputs are identical.

The symbol, truth table and logic diagram of two input EXOR gate is shown in fig., The inputs are labeled as A and B. The output is labeled as Y. The output Y is 1, if both inputs are different.

- The Boolean equation of EXOR gate is $Y = A \oplus B = A \cdot \bar{B} + \bar{A} \cdot B$

An encircled plus sign (\oplus) is used to show the EXOR operation.

Inputs		Output
A	B	$Y = A \oplus B$
0	0	0
0	1	1
1	0	1
1	1	0



a) Symbol

b) Truth table

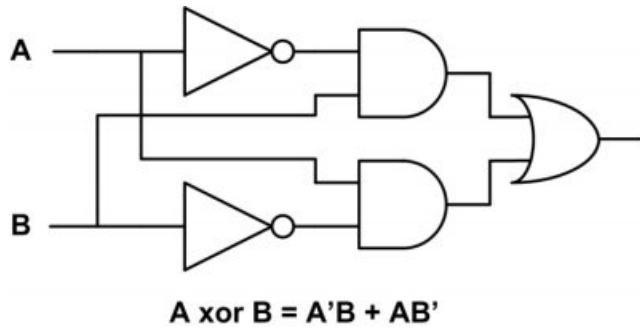

C) Logic diagram

f) EXNOR gate

The EXNOR gate contains two or more inputs and only one output. It is the complement of XOR gate.

- Logic operation

The EXNOR gate gives a high output when both the inputs are identical.

The EXNOR gate gives a low output when both the inputs are different.

The symbol, truth table and logic diagram of two input EXNOR gate is shown in fig. The symbol of EXNOR gate is an EXOR gate with a small circle on the output. The small circle represents inversion. The inputs are labeled as A and B. The output is labeled as Y. The output Y is 1, if both inputs are identical.

The Boolean equation of EXNOR gate is $Y = A \oplus B = A \cdot B + A \cdot B$

Inputs		Output
A	B	$Y = A \oplus B$
0	0	1
0	1	0
1	0	0
1	1	1

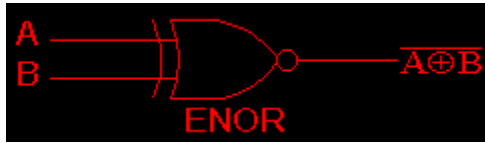

a) Symbol

b) Truth table

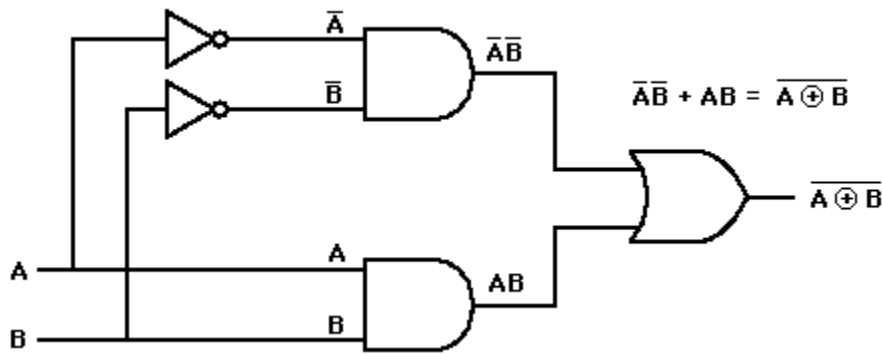

www.binils.com

C) Logic diagram

4.13.2 Universal Logic gates

A universal logic gate is a logic gate that can be used to construct all other logic gates. By using universal gate any Boolean function can be implemented without using other gates.

NAND gate and NOR gate are used as universal gates. Examples are given below.

NAND gate as Universal gate

AND, OR, NOT can be realized using NAND gates as shown below.

a) Realization of NOT gate

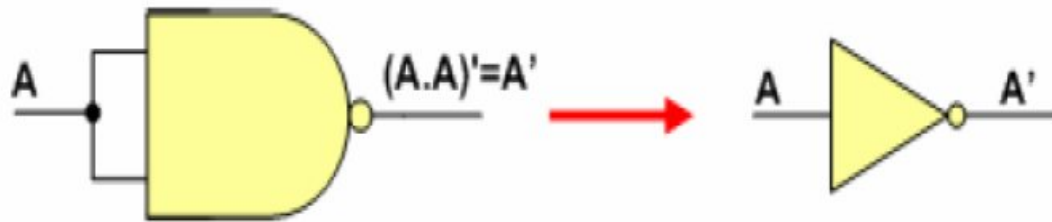

The two inputs of NAND gate are tied together and the input A is applied.
 The output expression of NAND gate = $A.A = A'$

b) Realization of AND gate



AND gate is realized by using the combination of NAND gate and NOT gate.
 Input A and B are applied to first NAND gate.
 The output of first NAND gate = $A.B$
 The second NAND gate is used as NOT gate.
 The output of second NAND gate = $A.B = A.B$

c) Realization of OR gate

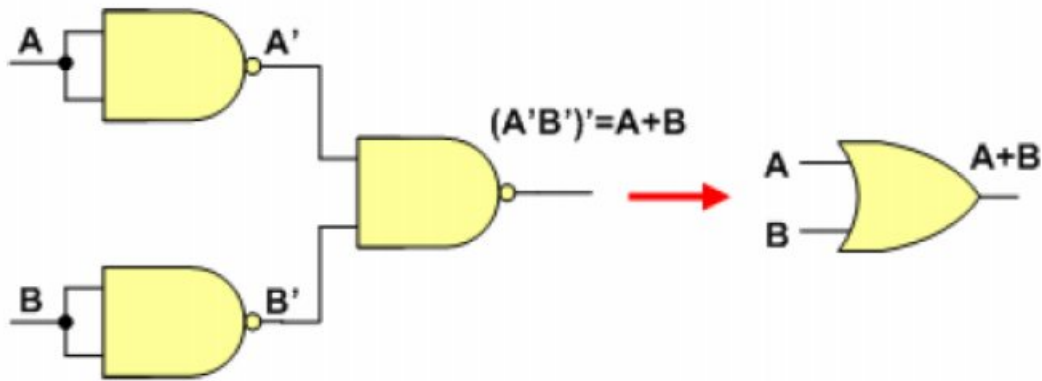

OR gate can be realized using three NAND gates. Two NAND gates are used as NOT gates. They provide the outputs A' , B' for the inputs A , B respectively. The output of these NAND gates A' and B' are given as input of third NAND gate.

Output of third NAND gate = $A \cdot B$

By using De-morgans theorem $A \cdot B = (A + B)'$

$$A \cdot B = (A + B)' = A + B$$

NOR gate as Universal gate

AND, OR, NOT can be realized using NOR gates as shown below.

a) Realization of NOT gate

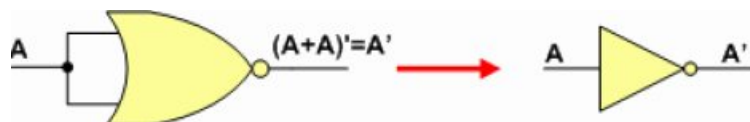

The two inputs of NOR gate are tied together and the input A is applied.

The output expression of NOR gate = $(A + A)' = A'$

b) Realization of AND gate

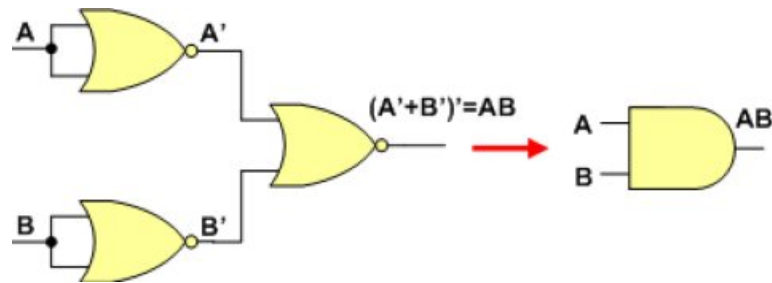

AND gate can be realized using three NOR gates. Two NOR gates are used as NOT gates. They provide the outputs A', B' for the inputs A, B respectively. The output of these NOR gates A' and B' are given as input of third NOR gate.

Output of third NOR gate = $A + B$

By using De-morgan's theorem $A + B = A \cdot B$

$$A + B = A \cdot B = A \cdot B$$

c) Realization of OR gate

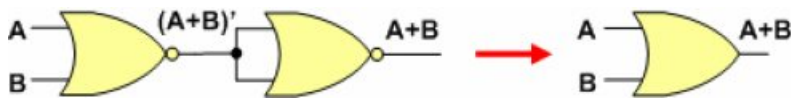

OR gate is realized by using the combination of NOR gate and NOT gate.

Input A and B are applied to first NOR gate.

The output of first NOR gate = $A + B$

The second NOR gate is used as NOT gate.

The output of second NOR gate = $A + B = A + B$

REVIEW QUESTIONS

PART- A

1. Draw the symbol of diode.
2. What is forward biasing of diode.
3. Define biasing. Mention its types.
4. Explain the use of diode in rectifiers.
5. Write the application of rectifiers.
6. why do you need filter in rectifiers.
7. What is the difference between on line UPS and Off line UPS.
8. What is rectifier
9. What is inverter
10. Write the application of inverters.
11. Write the application of SMPS.
12. What is the function of voltage regulator
13. What is universal gate.
14. Why is NAND gate called as universal gate.
15. State the application of LED.

PART- B

1. With diagram explain the forward biasing of diode.
2. With diagram explain the reverse biasing of diode.
3. What is positive logic and negative logic
4. Draw the diagram and wave form of half wave rectifier
5. Draw the diagram and wave form of full wave rectifier
6. Draw the diagram and wave form of bridge rectifier

7. Draw the block diagram of regulated power supply.
8. Draw the block diagram of SMPS.
9. Draw the block diagram of Off line UPS.
10. Draw the block diagram of On line UPS.
11. Write short note on IC voltage regulator.
12. Explain Universal logic gates.
13. Write symbol and truth table of NAND gate.
14. Write symbol and truth table of NOR gate.
15. Write symbol and truth table of EXOR gate.

www.binils.com

PART- C

1. With diagram explain the VI characteristics of PN junction diode.
2. Explain half wave rectifier and draw the wave forms.
3. Explain full wave rectifier and draw the wave forms.
4. Explain bridge rectifier and draw the wave forms.
5. With block diagram explain regulated power supply.
6. With block diagram explain SMPS.
7. With block diagram explain on line UPS.
8. With block diagram explain OFF line UPS.

9. With circuit diagram explain the operation of inverter.
10. a) Write short notes on LCD
b) Write short notes on seven segment LED display
11. Draw the symbols and write the truth tables of AND, OR, NOT, NAND, NOR gates.

www.binils.com

UNIT V

CONTROL ELEMENTS AND PLC

5.1 FUSE

- Fuse is a piece of wire of a material with a very low melting point. When a high current flow through the circuit due to Overloading or a Short circuit, the wires gets heated and melts.
- As a result, the circuit is broken and current stops flowing.
- It must be remembered that fuse wire is always connected to the LIVE wire.

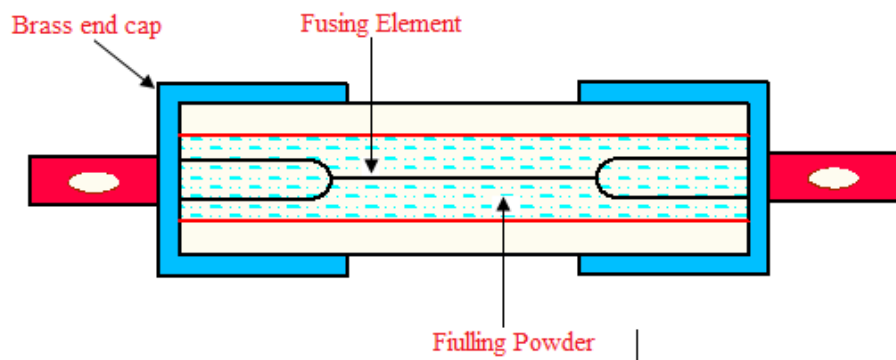

Fig.5.1 Construction of HRC fuse

5.1.1 Construction

- Figure 5.1 shows the construction of a typical high rupturing capacity (HRC) fuse link.

- The fuse element is surrounded by a filler material such as quartz sand which provides effective heat transfer.
- The fuse element can sustain small overloads for longer duration but in case of large overloads and short circuits the small cross-section of the fuse element melts quickly and opens the circuit.
- Fuses are provided into the circuit through fuse base and fuse carriers generally made of Bakelite material. Fuse is inserted in the fuse carrier which is then fixed in the fuse base.

5.1.2 Selection of fuse

- To select the proper fuse wire to be inserted in a circuit two factors viz (a) maximum current rating of the circuit and (b) current rating of the smallest size of wire.
- The type of wire to be selected to use as a fuse wire depends upon the type of load connected to the circuits. i.e., steady loads and fluctuating loads. (The steady load covers the heating loads and the fluctuating load consists of motor, capacitor and transformer loads, all of which take transient over current when they are switched into the circuit.)
- In steady load circuits, the fuse rating should be equal to or next greater than the ratings of the smallest cable used in the circuit.
- In fluctuating load circuits, it is necessary to select fuses of rated current greater than that of the cable of the circuit.

5.1.3 Necessity of fuse

- The fuse is provided in an electric circuit to protect the apparatus connected to it from being damaged due to excessive current.
- If no fuse or other similar device is provided in the circuit then a dangerous situation would be created on developing of faults such as over load, short-circuit or earth faults.
- In case of overload, short circuit and heavy earth faults, a heavy current will circuit to flow through the cables or wires, apparatus etc., these will get heated and so damaged. The fire may also break.
- In case of earth leakage fault, (i.e. on becoming to be alive and at much higher potential above that of the earth.) any person coming in contact with the metal body of the apparatus is liable to get an electric shock, even if that is earthed.

5.1.4 Fuse Switch Unit

- Figure 5.2 (a) shows separate fuse switch unit where, the switch and fuse two elements separately used in a electric circuit.
- In figure 5.2(b) Development of a new type of called, fuse switch unit, has led to the use of a modified power circuit.

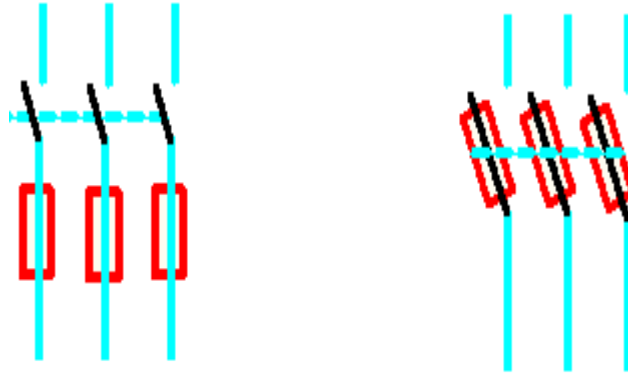

Fig.5.2 (a) Separate fuse switch unit and (b) fuse switch unit (combined)

- The advantage of using fuse switch unit is that the number of electrical joints becomes less due to the elimination of one element from the circuit.
- Hence requires less maintenance, and the space required is less as the combination fuse switch occupies less space than fuse / fuse base and switch when used separately.
- Fuse switch units are of two types namely (i) where the fuse is stationary and (ii) where the fuse is mounted on the moving assembly.
- Advantages of stationary type compared to moving assembly type fuse are: (1) The moving assembly weight is less as it does not carry the fuse, thus it is more reliable against mechanical failure. (2) There is less deterioration of electrical joints between fuse and fuse switch.

5.2 SENSORS

- A sensor is a device that measures a physical quantity and converts it into a 'signal' which can be read by an observer or by an instrument.

Examples

1. In a mercury-based glass thermometer, the input is temperature. The liquid contained expands and contracts in response, causing the level to be higher or lower on the marked gauge, which is human-readable.
2. A photo sensor detects the presence of visible light, infrared transmission (IR), and/or ultraviolet (UV) energy.

5.2.1 Photoelectric sensor

- A photoelectric sensor emits a light beam (visible or infrared) from its light-emitting element. A reflective-type photoelectric sensor is used to detect the light beam reflected from the target. A

through-beam type sensor is used to measure the change in light quantity caused by the target crossing the optical axis.

Principle and major types

A beam of light is emitted from the light emitting element and is received by the light receiving element.

(a) Reflective model

Both the light emitting and light receiving elements are contained in a single housing. The sensor receives the light reflected from the target.

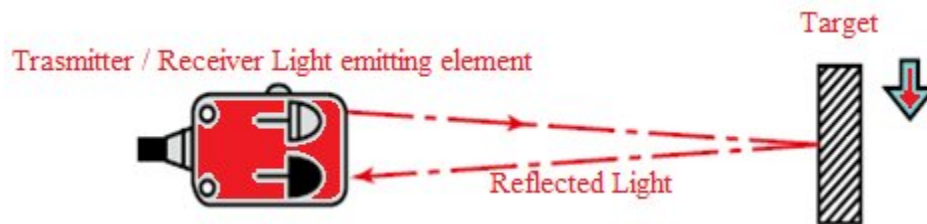

Fig.5.3 (a) Reflective type photoelectric sensor

(b) Through-beam model:

The transmitter and receiver are separated. When the target is between the transmitter and receiver, the light is interrupted.

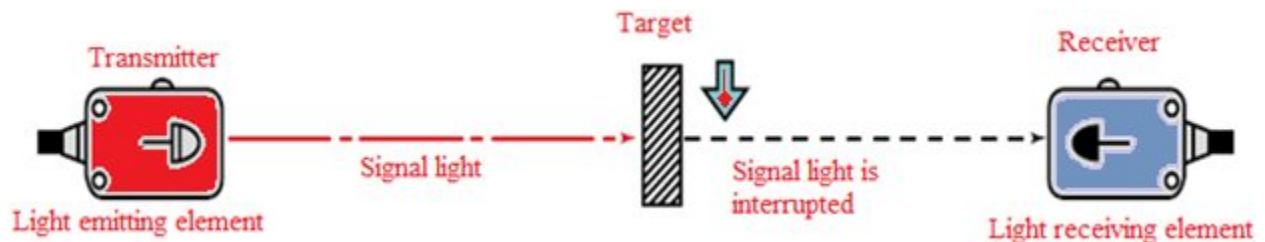

Fig.5.3 (b) Through-beam type phot electric sensor

(c) Retro-reflective model

Both the light emitting and light receiving elements are contained in same housing. The light from the emitting element hits the reflector and returns to the light receiving element. When a target is present, the light is interrupted.

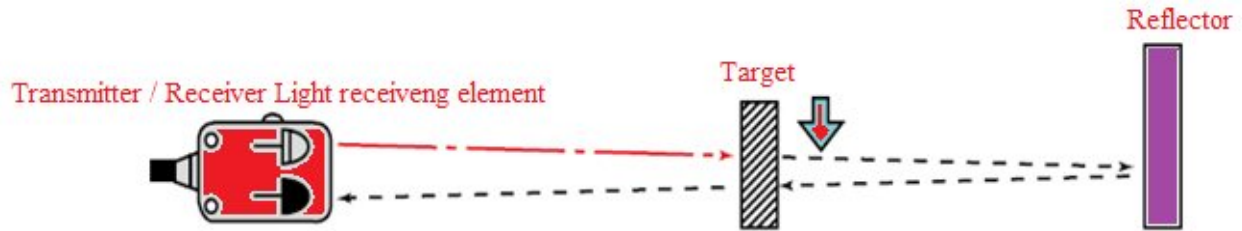

Fig.5.3 (c) Retro-reflective type photoelectric sensor

5.2.2 Inductive proximity sensor

Inductive Proximity sensors basically convert movement of person or thing into electrical form without having any physical contact.

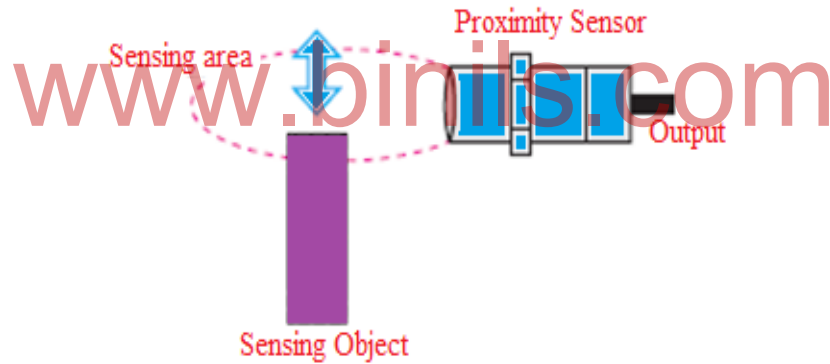

Fig. 5.4 (a) inductive proximity sensor (schematic)

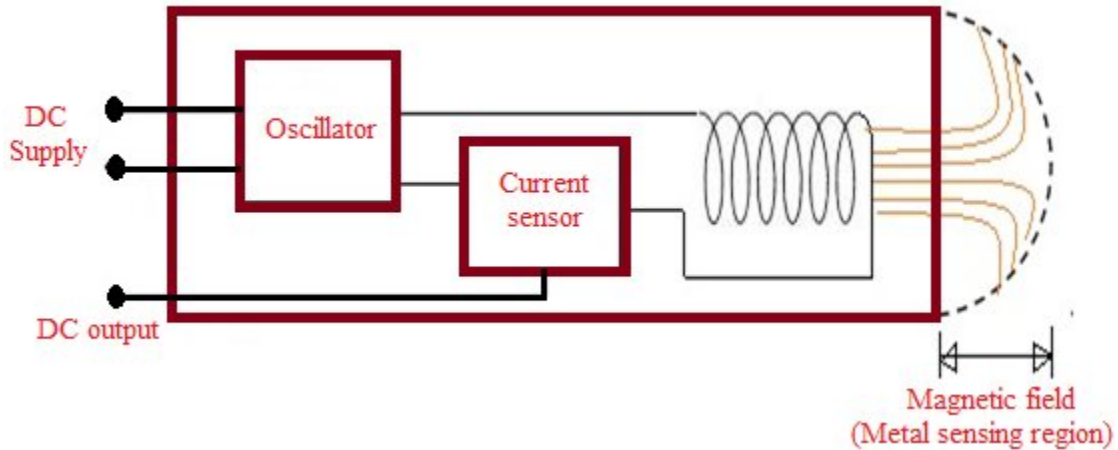

Fig. 5.4 (b) Block diagram of inductive proximity sensor

- Inductive type detects metallic objects such as aluminum, iron, copper and brass etc. Here coupling condition of transformer is basically replaced by impedance change.
- This impedance change occurs due to eddy current losses. This impedance change is similar to inserting resistance in series with the object being sensed.
- Figure 5.4 depicts inductive type of proximity sensor which works on inductance principle. It is simple to make this type of sensor.
- There are four basic components needed viz. coil, oscillator, detection circuitry and output circuitry.
- Oscillator will produce fluctuating magnetic field around the coil. This coil is positioned near the device to be detected. Eddy current produced on the metal object reduce the sensor's own oscillating fields.
- Detection circuit will monitor this strength of oscillator and will trigger the output when it goes below threshold.

5.2.3 Temperature sensors

A temperature sensor is a device, typically, a thermocouple or thermistor that provides for temperature measurement through an electrical signal.

Thermocouple

- A thermocouple, shown in Fig.5.5, consists of two wires of dissimilar metals joined together at one end, called the measurement ("hot") junction.
- The other end, where the wires are not joined, is connected to the signal conditioning circuitry traces, typically made of copper.
- This junction between the thermocouple metals and the copper traces is called the reference ("cold") junction.

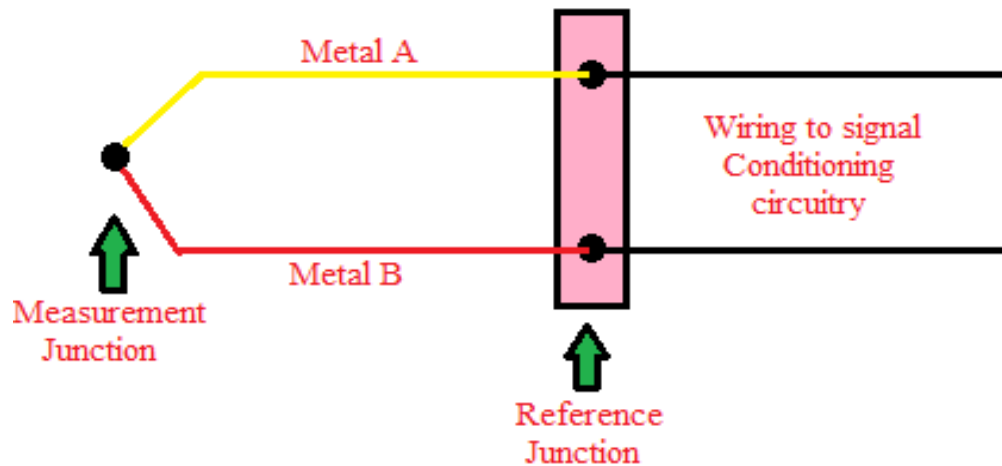

www.binils.com

Fig. 5.5 Thermocouple.

- The terms "measurement junction" and "reference junction" are the traditional "hot junction" and "cold junction." (The traditional naming system can be confusing because in many applications the measurement junction can be colder than the reference junction.)
- The voltage produced at the reference junction depends on the temperatures at both the measurement junction and the reference junction.
- Since the thermocouple is a differential device rather than an absolute temperature measurement device, the reference junction temperature must be known to get an accurate absolute temperature reading.
- This process is known as reference junction compensation (cold junction compensation).
- Thermocouples are used in a variety of applications up to approximately +2500°C in boilers, water heaters, ovens, and aircraft engines—to name just a few.

- The most popular thermocouple is the type K, consisting of Chromel and Alumel with a measurement range of -200°C to $+1250^{\circ}\text{C}$.

Thermistors:

- Thermistors are temperature sensitive resistors. All resistors vary with temperature, but thermistors are constructed of semiconductor material with a resistivity that is especially sensitive to temperature.
- However, unlike most other resistive devices, the resistance of a thermistor decreases with increasing temperature
- Thermistors are inexpensive, easily-obtainable temperature sensors. They are easy to use and adaptable.
- Because of these qualities, thermistors are widely used for simple temperature measurements. They're not used for high temperatures.
- Initially, Thermistor is placed in the environment whose temperature is to be measured.
- Then, Thermistor is connected in a series simple circuit consisting of battery and micro-ammeter as shown above.

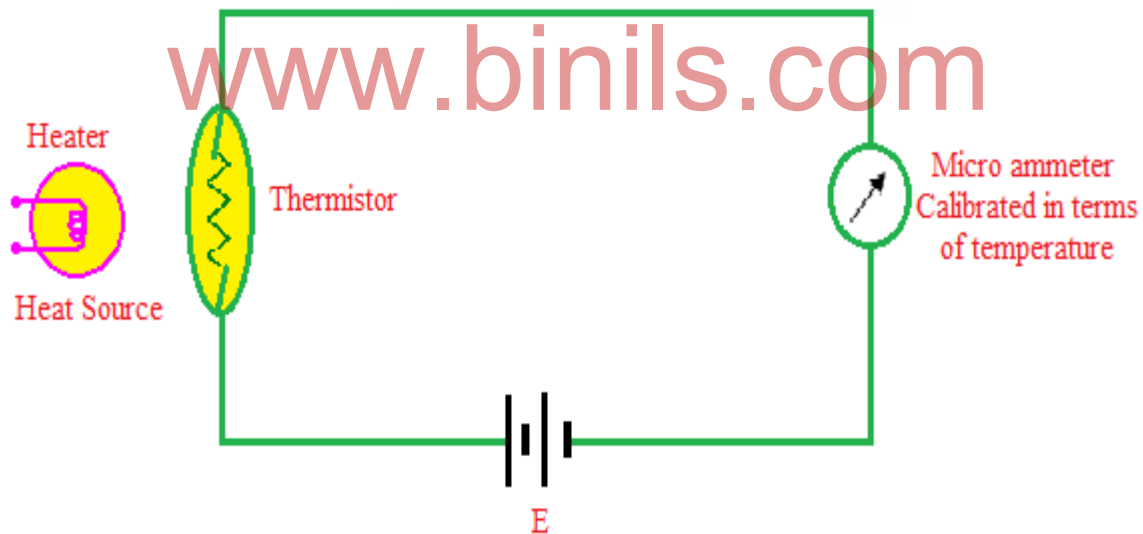

Fig. 5.6 Measurement of temperature using thermistor.

- Any change in temperature causes a change in resistance of Thermistor.
- Hence, corresponding change in circuit current. By directly calibrating micro ammeter in terms of temperature, we can measure temperature.

Advantages

- Low cost
- Sensitivity is high
- Small in size.
- Good stability.
- High output signal.

Disadvantages

- Non-linear output is seen.
- Not suitable for high temperature measurement.
- Requires external power supply.

Applications

- Used for measurement and control of temperature.
- Used for providing time delay.
- Used as temperature compensation element in electronic equipments.
- Used for measuring thermal conductivity of a medium.

5.3 SWITCHES

A switch is an electrical component that can break an electrical circuit, interrupting the current or diverting it from one conductor to another.

2.11.4 Push button switch

It is a pilot device which provides control of equipment by pressing an actuator which looks like a button.

Construction

- Push button switch can be divided into two parts. One part is the mechanical actuator or button assembly and the second part is the electrical portion or contact assembly called the contact block.
- The mechanical actuator or button assembly can be of momentary-contact spring returned type of maintained contact type.
- The momentary-contacts spring returned push button remains actuated as long as the button is physically held pressed by the human operator.

Working

- Maintained contact push buttons are held actuated by some latching mechanism even when the operator releases the pressure on the push button.
- Such units consists of two push buttons, only one remains in actuated position at a time, when the other button is pressed the first one gets released.
- A spring returned momentary contact push button is shown in Fig.5.7 (a). The contact block has two contacts, one normally open (NO) and other normally closed (NC).
- When the push button is pressed, NC contacts opens and NO contact closes.
- When the push button is released a spring inside the actuator assembly brings back the push button and a spring inside the contact block brings the contacts back to their normal position.



Fig. 5.7 (a) Push button switch

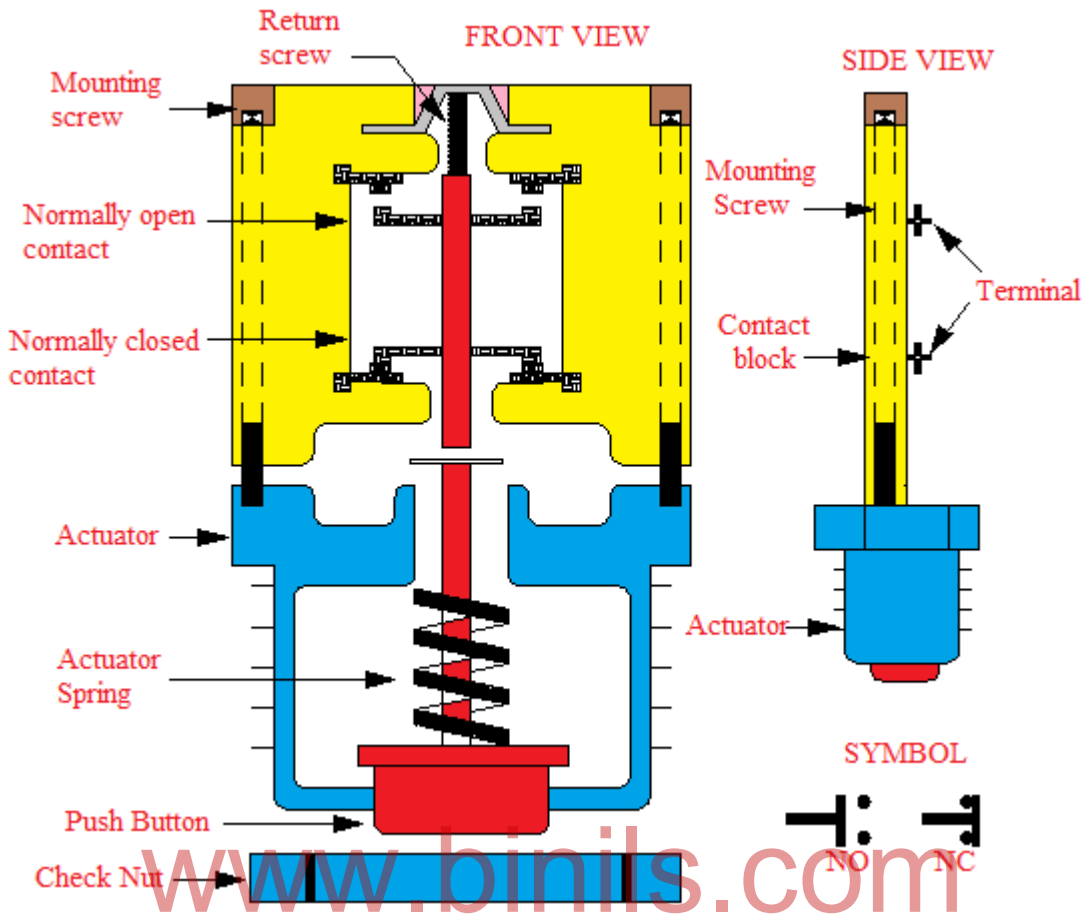

Fig. 5.7(b) Push button switch (schematic)

- **Types:** 1) Recessed button type 2) Mushroom head type 3) Illuminated type 4) Key lock type.
- Colour of the button is also an important factor in push button switches. Standards have been developed which specify certain colour for a particular function.
- For example, red push buttons are used for stop and emergency stop operations, while green push buttons are used for start operation.

5.3.2 Selector Switch

- A selector switch will enable the operator to predetermine the manner in which his machine is to operate.
- As with push-button switches, selector switches also have two main parts, the mechanical actuator and the contact block.
- Selector switches are usually of the maintained position types, although momentary spring return selectors are also available.
- Selector switches can have single break contacts or double break contacts. The symbols for both these type of contacts have been shown in fig.5.8. The selector switches are generally made for four positions.
- As the number of positions increase to four, manufacturer provide charts of tables which display positions of the selector switch actuator.

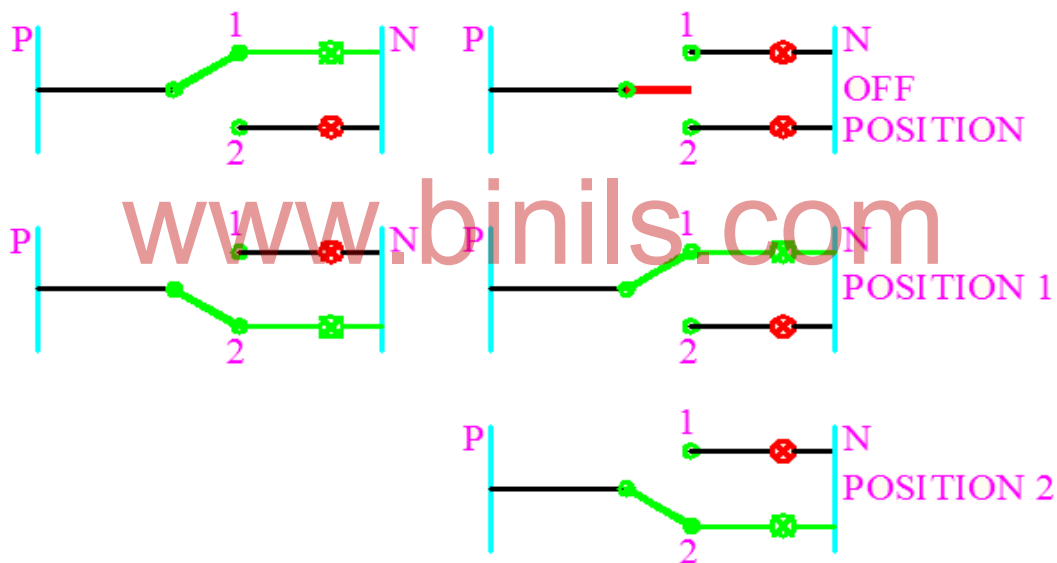

Fig.5.8 connection of two position and three position selector switches in a simple circuit

- Figure 5.9 shows a four position selector switch. Note the use of x under the position number. This indicates that the contact in line with x is closed in that position.

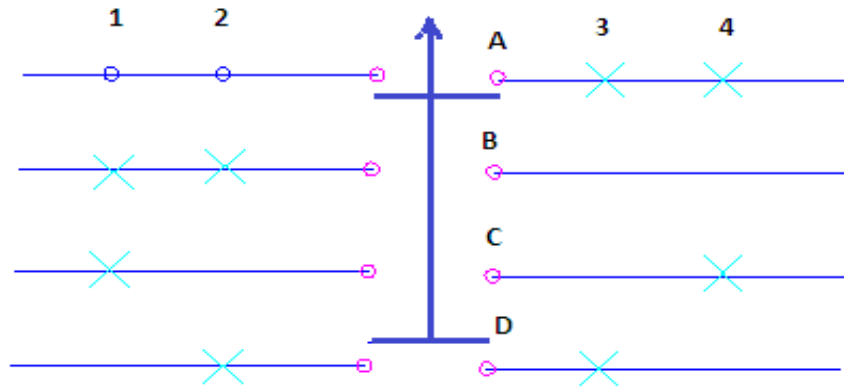
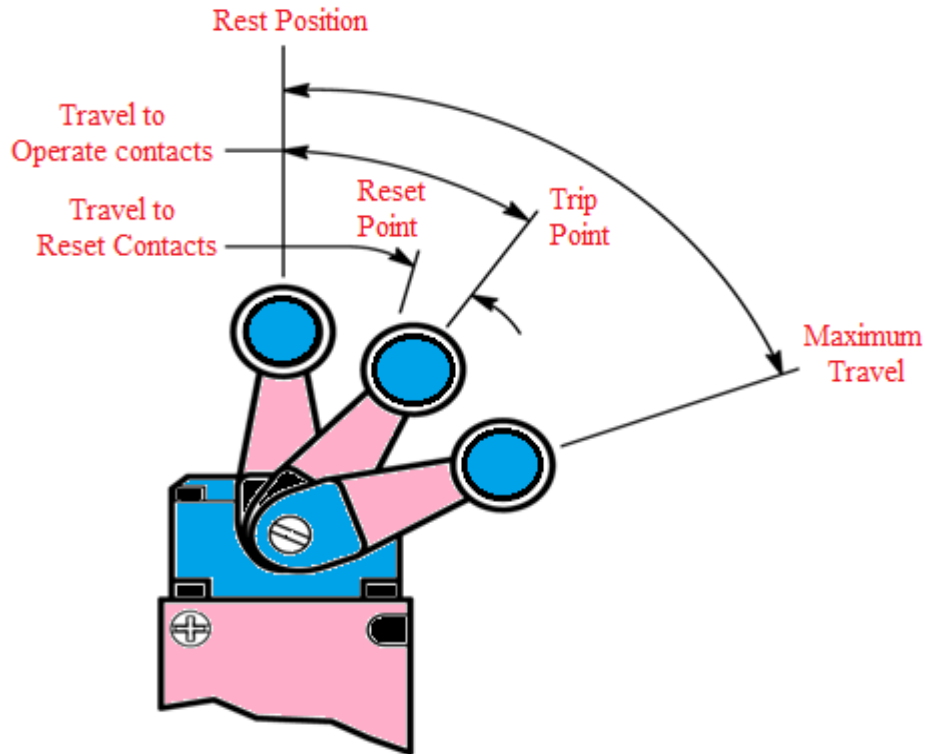

Fig.5.9 Symbolic representation of four position selector switch

- Below position 1 x is against contact B and C i.e., position 1 contact B and C are closed. In position 2 contacts B and D will close, further in position 3 contacts A and D will close and in position 4 contacts A and C will close.

5.3.3 Limit switch

- A limit switch is an electromechanical device that consists of an actuator mechanically linked to a set of contacts. When an object comes into contact with the actuator, the device operates the contacts to make or break an electrical connection.
- Limit switches are used in a variety of applications and environments because of their ruggedness, ease of installation, and reliability of operation.
- They can determine the presence or absence, passing, positioning, and end of travel of an object. They were first used to define the limit of travel of an object; hence the name “Limit Switch.”



www.binils.com

Fig.5.10 Limit switch

Construction

- **Actuator:** The actuator is the portion of the switch that comes in contact with the object being sensed.
- **Head:** The head houses the mechanism that translates actuator movement into contact movement. When the actuator is moved as intended, the mechanism operates the switch contacts.
- **Contact Block:** The contact block houses the electrical contact elements of the switch. It typically contains either two or four contact pairs.
- **Terminal Block:** The terminal block contains the screw terminations. This is where the electrical (wire) connection between the switch and the rest of the control circuit is made.

- **Switch Body:** The switch body houses the contact block in a plug-in switch. It houses a combination contact block and terminal block in the non plug-in switch.
- **Base:** The base houses the terminal block in a plug-in switch. Non plug-in switches do not have a separate base.

Working

- If the plunger is left pushed in for a long time, the air in the Limit Switch will escape and the internal pressure will become equivalent to atmospheric pressure. This will cause the plunger to tend to reset slowly even if an attempt is made to quickly reset it.
- To prevent this problem from occurring, design the system to limit the amount of air compressed by pushing in the plunger to 20% or less of the total air pressure in the Limit Switch.
- The amount of plunger movement is increased at the end of the lever (i.e., roller) by the lever ratio, and so an absorption mechanism is generally not used.
- Limit switches are used to stop a mechanical movement of a machine and may also be used to stop a particular movement, and initiate another movement.
- The simple application of a limit switch is in producing automatic to and fro movement of a planar machine bed shown in fig.5.10. It must be understood here that a limit switch is not used as a mechanical stop.
- A limit switch controls the electrical signal which is responsible for mechanical stop/movement. (1) A simple limit switch, (2) Rotary Cam type Limit switch and (3) Heavy duty Limit switch are the types of limit switch.

5.3.4 Pressure Switch

- Pressure switches are used in the control systems to sense pressure of gas, air or liquid and feed a signal into the electrical control circuit.
- Pressure can have a normally open or normally closed contact or it can have both types of contacts.

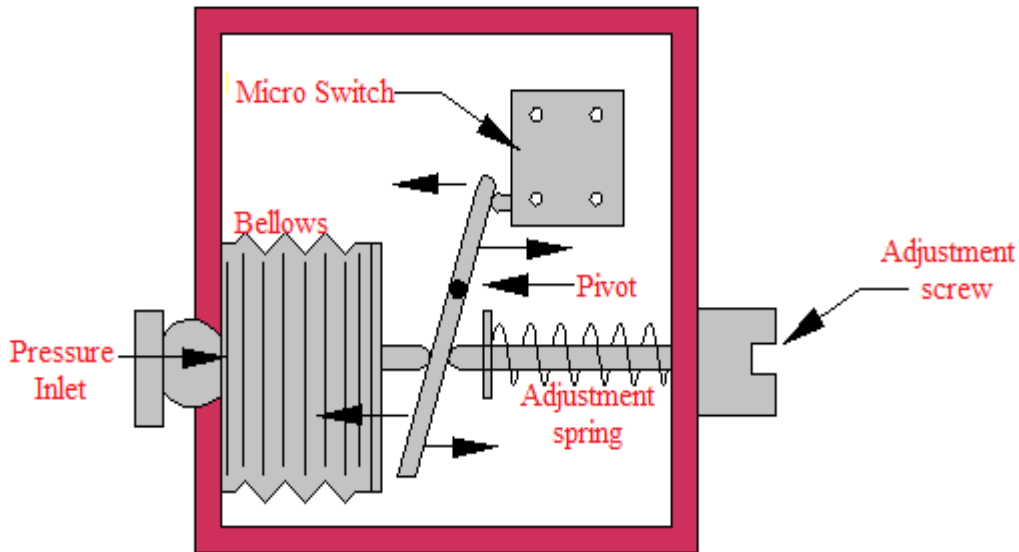

Fig .5.11 Bellow type pressure switch

Construction and Working

- The extra feature is the differential setting. The cut out point of a pressure switch is that pressure at which its contact opens to de-energize the associated pump / compressor from raising the pressure further or to stop a machine cycle.
- The pressure switches basically falls into three general categories depending upon the manner of operation. The principle of working of one type, called the bellow type is illustrated in the fig.5.11. The actual switches, however, vary considerably in their mechanical design.
- The bellow expands or contracts depending upon the pressure. The movement of the bellow tilts the lever which rests on the micro switch knob.
- The thrust of lever on the micro switch knob can be varied by adjusting the screw. This would change the pressure at which the micro switch contact will change over.
- The second general type of pressure switch uses a diaphragm in place of bellow, the other operation being the same. The third type uses a hollow tube of semicircular shape.
- When pressure is given to this tube, it tries to straighten up and this action is transformed into a rotary motion and through a mechanical linkage a micro switch is actuated.

5.3.5 Temperature switch (Thermostats)

- Temperature switches or thermostats are used for maintaining a prescribed value of temperature. The first type of temperature switch is bimetallic strip type which works in a similar way to that of an overload relay.

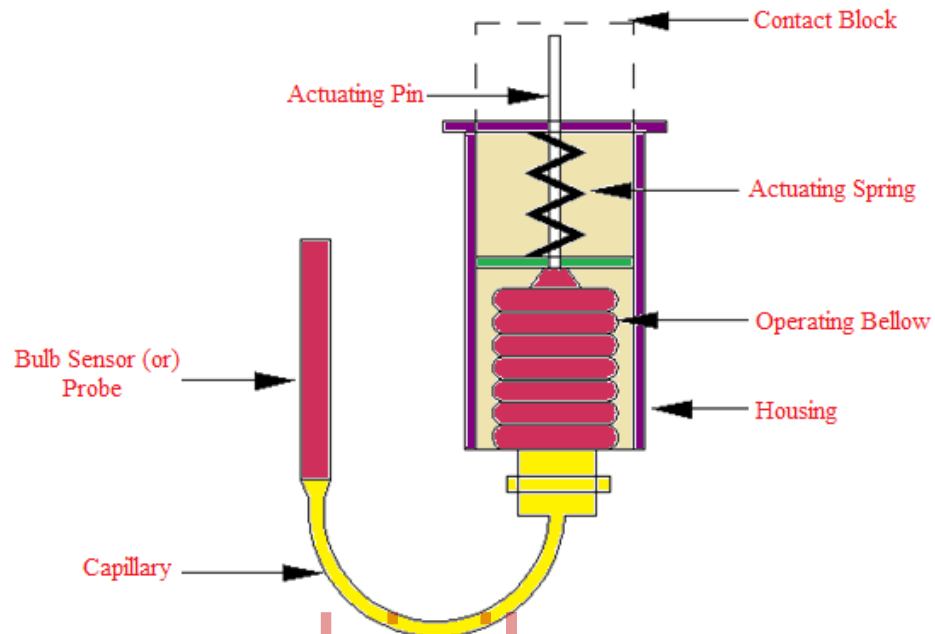

www.binils.com

Fig.5.12 Capillary type thermostat

Construction and Working

- Another type of temperature switch which has wide industrial application uses a liquid, a gas or a vapour as the sensing element in a short length of pipe or in a long thin tube called capillary tube with a bulb at one end.
- The expansion of the liquid, gas or vapour is utilized to actuate the switch contact. The temperature ranges for these units are as follows:

- (1) Liquid filled 100°F to 2200°F, (2) Gas filled 100°F to 1000°F, (3) Vapour filled 50°F to 700°F.
- The probe is inserted at the location where the temperature is to be measured, the liquid in the bulb expands and pressure is developed in the bellows which also expands and moves the actuating pin which operates the contact operating mechanism.
- This liquid filled type of thermostat has a very quick response. If the length is longer then, the response is slower. The disadvantage of this type is that the capillary tube gets easily damaged if it is not carefully handled.

5.3.6 Float switch

- A float switch is a device used to detect the level of liquid within a tank. The switch may be used in a pump, an indicator, an alarm, or other devices.
- Float switches are used to maintain liquid levels within a certain range in a tank by energizing a pump when the liquid level falls to a certain lower pre-set height and by de-energizing, the pump when liquid level rises above a certain higher pre-set height.

www.binils.com

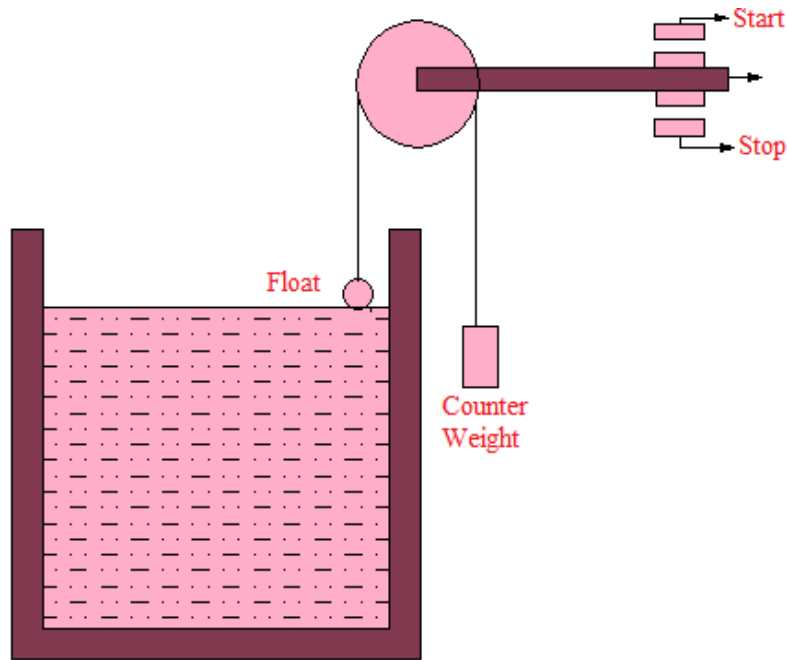

www.binils.com

Fig.5.13 Level sensing using a float, chain pulley and counter weight

Construction and working

- This type of float switch uses a chain passing over a pulley with float at one end and a counter weight at the other end.
- The stopper fitted on both sides of the chain tilts the lever. The contact is opened or closed by the position of mercury placed in tube.
- The tube is mounted on the lever and the tilting of lever causes the contact to open or close.
- When the liquid level raises the float, the stopper on the left hand side of the chain tilts the lever in clock-wise direction and thus the switch contacts open.
- When the liquid level drops and the counter weight rises and at certain limit the stopper fixed on the right hand side of the chain pushes the lever and tilts it in the anticlockwise direction, the switch contact closes.

5.3.7 Reed switch:

- The **reed switch** is an electrical switch operated by an applied magnetic field.
- A graphical illustration of a reed switch, the circuit symbol and a simple diagram representing the construction of the switch are shown in fig.5.14.

Construction and working

- It consists of a pair of contacts on ferrous metal reeds in a hermetically sealed glass envelope.
- The contacts may be normally open, closing when a magnetic field is present, or normally closed and opening when a magnetic field is applied.

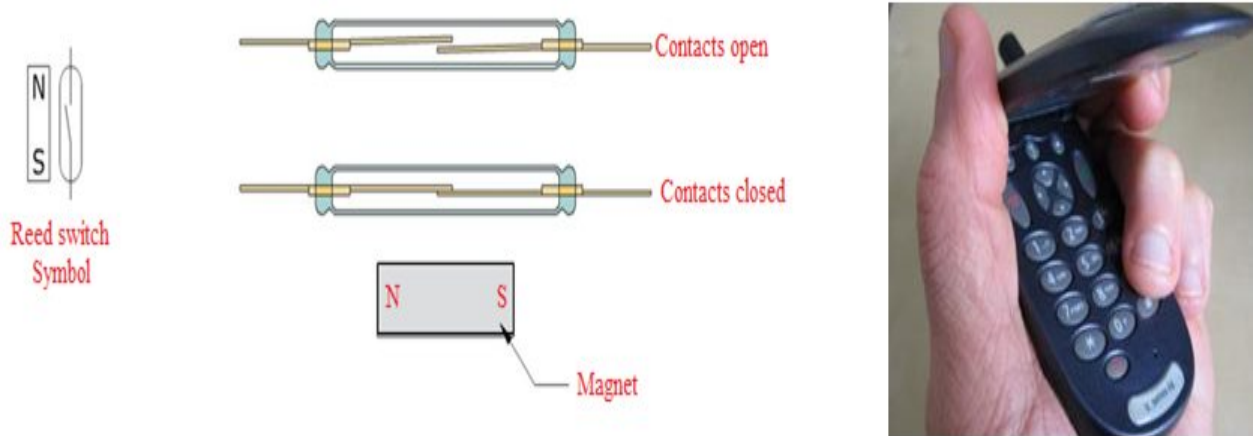

www.binils.com

Fig.5.14 (a) Reed switch & Reed switch usage diagram

- The switch may be actuated by a coil, making a reed relay, or by bringing a magnet near to the switch.
- Once the magnet is pulled away from the switch, the reed switch will go back to its original position.
- A flip cell phone switches on and off when you open or close it.
- It has a normally closed reed switch in the lower part of its body (where the keypad is) and a magnet in the upper part (where the screen is).
- When the phone is open, the reed switch and the magnet are relatively far apart. The contacts on the reed switch are pushed together and the power flows through the phone.
- However, if we close the case, we swing the magnet close to the reed switch and that pushes apart the contacts inside the switch. A circuit inside the phone senses this and switches off the power in an orderly way.

5.4 RELAY

A relay is a simple electromechanical switch made up of an electromagnet and a set of contacts.

Relay NO & NC - usage

- Normally Open (NO) – the circuit is connected when the relay is active and disconnected when inactive.
- Normally Closed (NC) – the circuit is connected when the relay is inactive and disconnected when active.

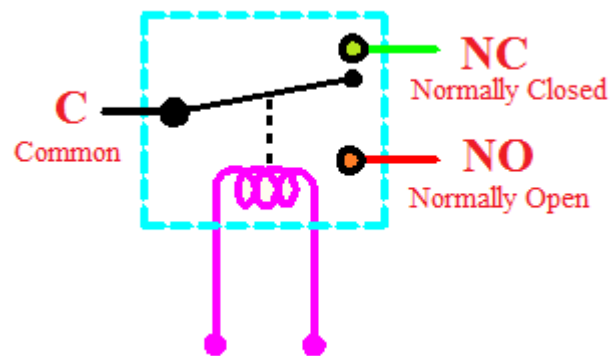

www.binils.com

Fig.5.15 Relay

- Relays are used wherever it is necessary to control a high power or high voltage circuit with a low power circuit, especially when galvanic isolation is desirable.
- The first application of relays was in long telegraph lines, where the weak signal received at an intermediate station could control a contact, regenerating the signal for further transmission.

5.4.1 Bimetallic thermal overload relay

- The relay consists of three bimetallic strips with current coils wound on them as shown in fig.5.16. The whole of the assembly is mounted on a Bakelite enclosure.
- Bimetallic strips comprising two dissimilar metals having different thermal coefficients of expansion are used for the three phases.
- Current flowing through the coils, heat the bimetallic strips. Upper ends of the strips are firmly held while lower ends are free to move.

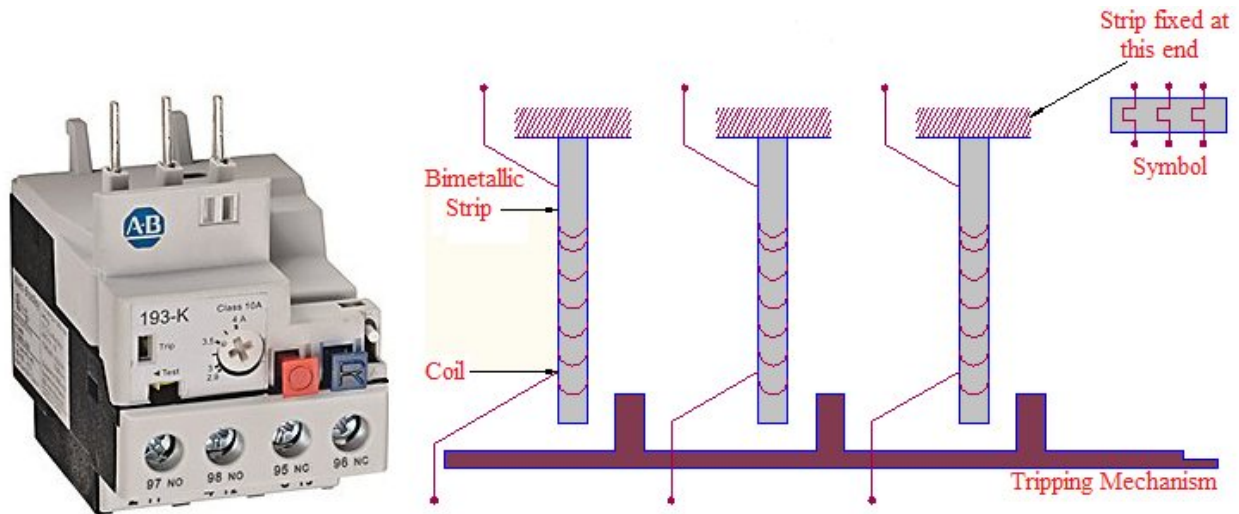

Fig.5.16 Bimetallic thermal overload relay

- When temperature of the strips increases due to current flowing through the coils, the strips bend towards right due to different expansion of metals.
- When the strips bend towards the right, the tripping mechanism gets actuated and opens the relay contact.
- More is the current flowing through the coils, faster will be the action of relay. A relay thus has inverse time characteristics.
- As the thermal relays are heat dependent the relay cannot distinguish whether the heat is from the current flowing through the coil or from the surroundings.
- Therefore changes in ambient temperature changes the relay characteristic. To compensate for the ambient temperature changes, relays are designed with temperature compensating strip.
- The compensated overload relays are unaffected by variation in ambient temperature from -22°C to 55°C .

5.5 CONTACTOR

- A contactor can be described as a magnetically closed switch. Contactors come in many forms with varying capacities and features.

- Contactors are used for switching ON and OFF of heavy loads like furnaces, heaters, capacitors, etc.
- A contactor consists of an electromagnet, a movable core, sets of stationary and moving contacts and an arc quenching structure.

Necessity of Contactor

- The use of a contactor is based strictly on the application. There are different types of contactors from "General Purpose" to types that are specifically designed for the intended application.
- The PRIMARY difference between a contactor and relay is the ability of the contactor to "make" and "break" the circuit under high current conditions.
- The contacts in a contactor are designed to handle the in-rush current of the "make" or energized function and the arcing between the contacts associated with the "break" function (de-energized).

5.5.1 Solenoid type Contactor

- In this type the movable contacts are attached to the movable core of a magnet.
- When the electromagnet coil is energized, the movable core is pulled to the stationary core, thus closing the contacts.

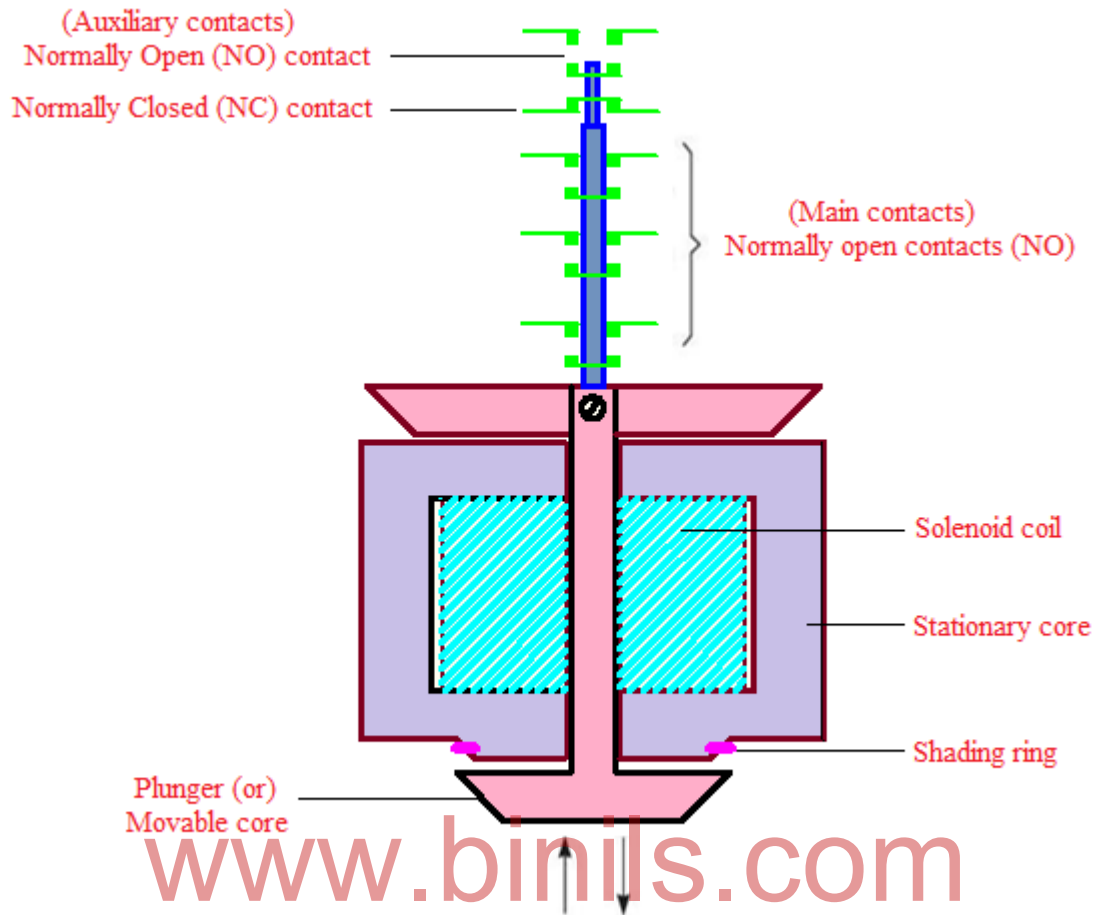

Fig.5.17 solenoid type contactor

Construction and working

- The contacts have been shown mounted in vertical plane though actually the contacts are in horizontal plane.

- The position of plunger i.e., movable core shown in the figure is for the coil in de-energized state.
- When the coil is energized, plunger moves up, moving contacts mounted on plunger also moves up and closes the normally open contacts.
- At the same time normally closed contacts open.
- When the coil is de-energized contacts are broken and they come back to their normal position by the pull of gravity. Mounting of contacts in horizontal plane reduces the size of the contactor.
- The pole faces of the magnet are provided with shading coil.
- This creates an out of phase flux to hold the magnet, closed during the zero points of alternating current thus preventing chatter of the contactor.

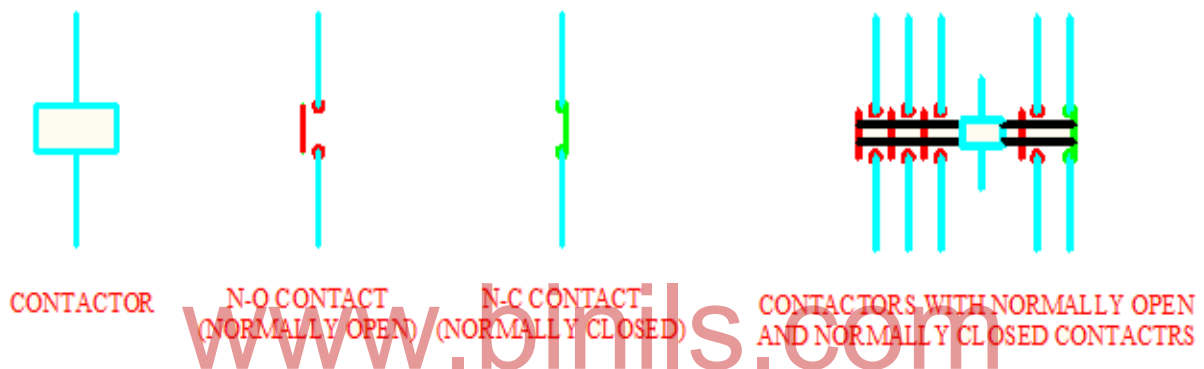

Fig.5.18 Symbols for contactor coil and contacts.

- Symbols used for contactor coil, contactor with main and auxiliary contacts, and photographic view of a contactor have been shown in figure. 5.18.

5.6 CIRCUIT BREAKERS

It is an automatically operated electrical switch designed to protect an electrical circuit from damage caused by over current or overload or short circuit.

5.6.1 Molded Case Circuit Breaker and Miniature Circuit Breaker (MCCB & MCB):

MCB:

- MCB stands for “Miniature Circuit Breaker”.
- Rated current under 100 amps.

- Interrupting rating of under 18,000 amps
- trip characteristics may not be adjusted
- Suitable for low current circuits (low energy requirement), i.e. home wiring.
- Generally, used where normal current is less than 100 Amps.

MCCB:

- MCCB stands for “Molded Case Circuit Breaker”.
- Rated current in the range of 10-2500 amps.
- Thermal operated for overload and & Magnetic operation for instant trip in SC (Short circuit conditions)
- Interrupting rating can be around 10k – 200k amps.
- Suitable for high power rating and high energy i.e. commercial and industrial use.
- Generally, used where normal current is more than 100 Amps.



Fig.5.19 MCB & MCCB

- An MCCB automatically isolates an electrical circuit under sustained overloads or short circuits. The breaker is opened by an electromagnetic release in case of short circuit faults.

- When the current is less than 10 times the setting of the thermal release the breaker trips due to thermal release and when current exceeds 10 times its value, the breaker is opened by magnetic release.

MCCB Features:

- The breaker is switched on by a toggle type switch. The operating mechanism is “quick-make, quick-Break”.
- The housing is made of eat resistant insulating material. All parts are enclosed in the housing except terminals.
- All phases are disconnected even when a fault occurs on only one of them.
- Arc chutes envelope each contact and draw the arc away from the contact tips thus quenching it rapidly.

5.6.2 Oil Circuit Breakers (OCB)

- Oil circuit breaker is a circuit breaker which uses oil as a dielectric or insulating medium for arc extinction.
- In oil circuit breaker the contacts of the breaker are made to separate within an insulating oil.
- When the fault occurs in the system the contacts of the circuit breaker are open under the insulating oil, and an arc is developed between them and the heat of the arc is evaporated in the surrounding oil.

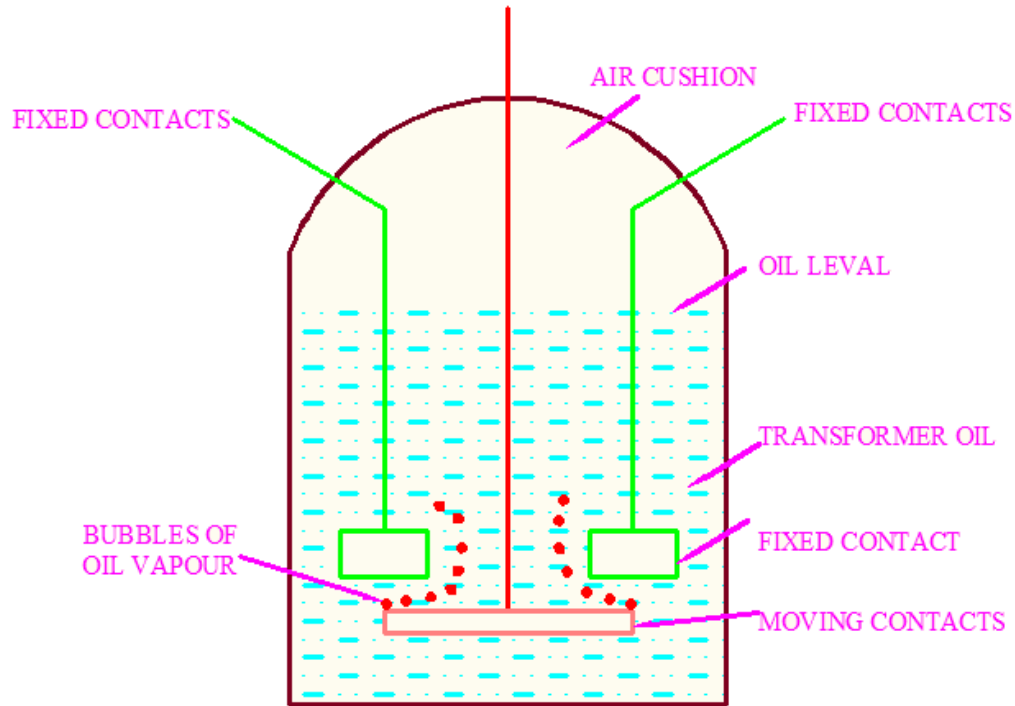

www.binils.com

Fig.5.20 Oil circuit breaker

- During the normal operating conditions, the contacts of the oil circuit breaker are closed and carry the current. When the fault occurs in the system, the contacts of the breaker are moving apart, and an arc is struck between the contacts.
- Due to this arc, a large amount of heat is liberated, and a very high temperature is reached which vaporizes the surrounding oil into gas.
- The gas, thus liberated surrounds the arc and its explosive growth around it displaces the oil violently.
- The arc is extinguished when the distance between the fixed and moving contact reaches a certain critical value, depends on the arc current and recovery voltage.

Advantages of Oil as an Arc Quenching

- The oil has a high dielectric strength and provides insulation between the contacts after the arc has been extinguished.
- The oil used in circuit breaker provides a small clearance between the conductors and the earth components. The hydrogen gas is formed in the tank which has a high diffusion rate and good cooling properties.

Disadvantages of Oil as an Arc Quenching

- The oil used in oil circuit breaker is inflammable and hence, cause a fire hazard.
- There is a risk of formation of explosive mixture with air.
- Due to decomposition of oil in the arc, the carbon particles is generated which polluted the oil and hence the dielectric strength of the oil decreases.

Maintenance of oil circuit breaker

After a circuit breaker has interrupted by short-circuit current, sometimes their contacts may get burnt due to arcing. Also, the dielectric oil gets carbonized in the area of the contacts, thereby losing its dielectric strength. This results in the reduced breaking capacity of the breaker. Therefore, the maintenance of oil circuit breaker is essential for checking and replacement of oil and contacts.

5.6.3 Earth Leakage Circuit Breaker (ELCB)

- ELCBs are the devices designed to provide protection against accidents by rapidly interrupting dangerous contact voltages which may be present in the faulty electrical equipments as a result of ground faults, insufficient insulation, insulation failure or misuse and sabotage.
- Basically the ELCB are of two types, voltage operated ELCBs and current operated ELCBs.

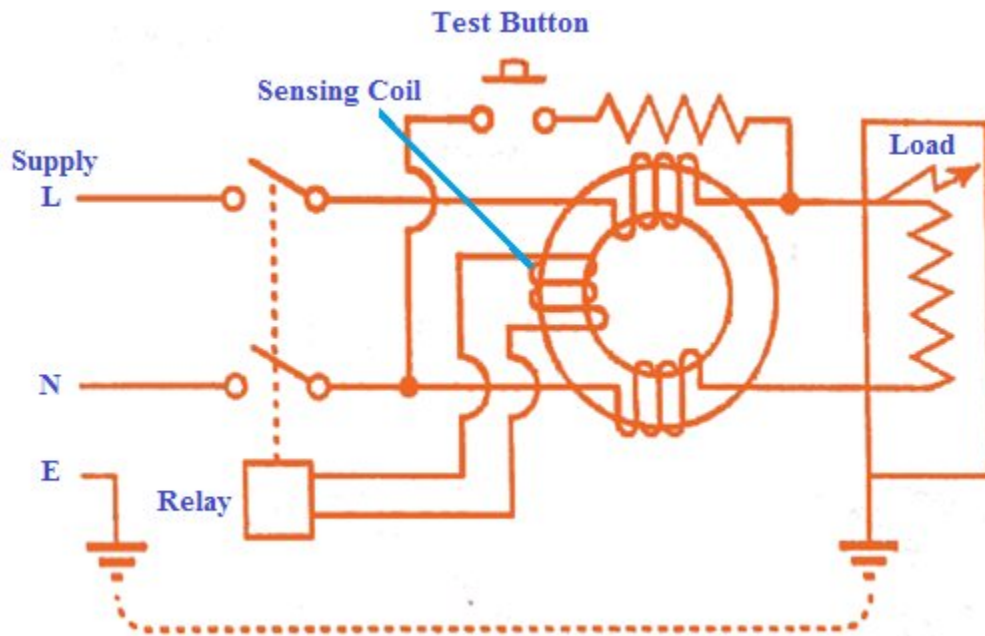

Fig.5.21 ELCB

- The current operated ELCBs are much more reliable in operations, easier to install and maintain. Any current even in milli amperes which is not returning to the source through the neutral is assumed to be flowing through the earth or through any insulating body.
- This differential current is immediately sensed by the current operated ELCB which switches off the electricity supply, protecting the people from dangerous electrical shocks and the insulations from failing and inviting dangerous fires.

Construction and Working:

- The figure 5.22 shows the circuit diagram of a residual-current earth leakage circuit breaker.
- The essential part of the ELCB is a toroid type core transformer with two opposed windings called primary. One is connected in series with the line and the other in series with the neutral.



www.binils.com

Fig.5.22 Current operated ELCB.

- As far as there is no leakage current, the line current is equal to the neutral current and the magnetic flux produced by the two primary windings oppose and cancel each other.
- Thus the secondary winding which is connected to the trip coil does not induce any voltage.
- However, when there is any leakage in the circuit, the line current differs from neutral current, thus inducing a voltage in the secondary and the trip coil opens the circuit.
- Working of the ELCB could be checked by the test button at intervals. Specification for ELCB should contain normal rated current, leakage current and the time duration within which the ELCB should trip.
- Some state electricity authorities in India, insists on the use of ELCB in each of the domestic installation as a safety measure.

5.7 PROGRAMMABLE LOGIC CONTROLLER (PLC)

It is a solid state system, with a programmable memory for storing instructions to implement specific functions such as logic, sequencing, timing, counting and arithmetic to control machine and processes.

5.7.1 Features of PLC

1. PLCs are designed to be operated in industrial environment with wide range of ambient temperature, vibration and humidity conditions. It is not affected by the electrical noise present in the industrial environment.
2. In computer the inputs are floppy drives and CD ROMs and output is a printer, but in PLC the inputs are signals from control elements like push-buttons, limit switches, temperature switches, pressure switches and transducers etc., installed on the machines to be controlled. Also the outputs are final control elements like contactors, solenoids, positioning valves, indication lights, and so forth.
3. The PLC is not a disc based system like PC. With a disc based system there is a continuous checking of what to do next. With a PLC the answer of what to do next is inherent, there is no consulting. The PLC program is stored in battery backed RAM or EPROM.
4. PLCs are designed to be operated in industrial environment with wide range of ambient temperature, vibration and humidity conditions. PLCs are designed to be programmed using RELAY LADDER LOGIC.
5. Sequential Logic Solver, Bit Operation, Data Transfer, Text handling, PID Calculation, Subroutines.

5.7.2 Block diagram of PLC:

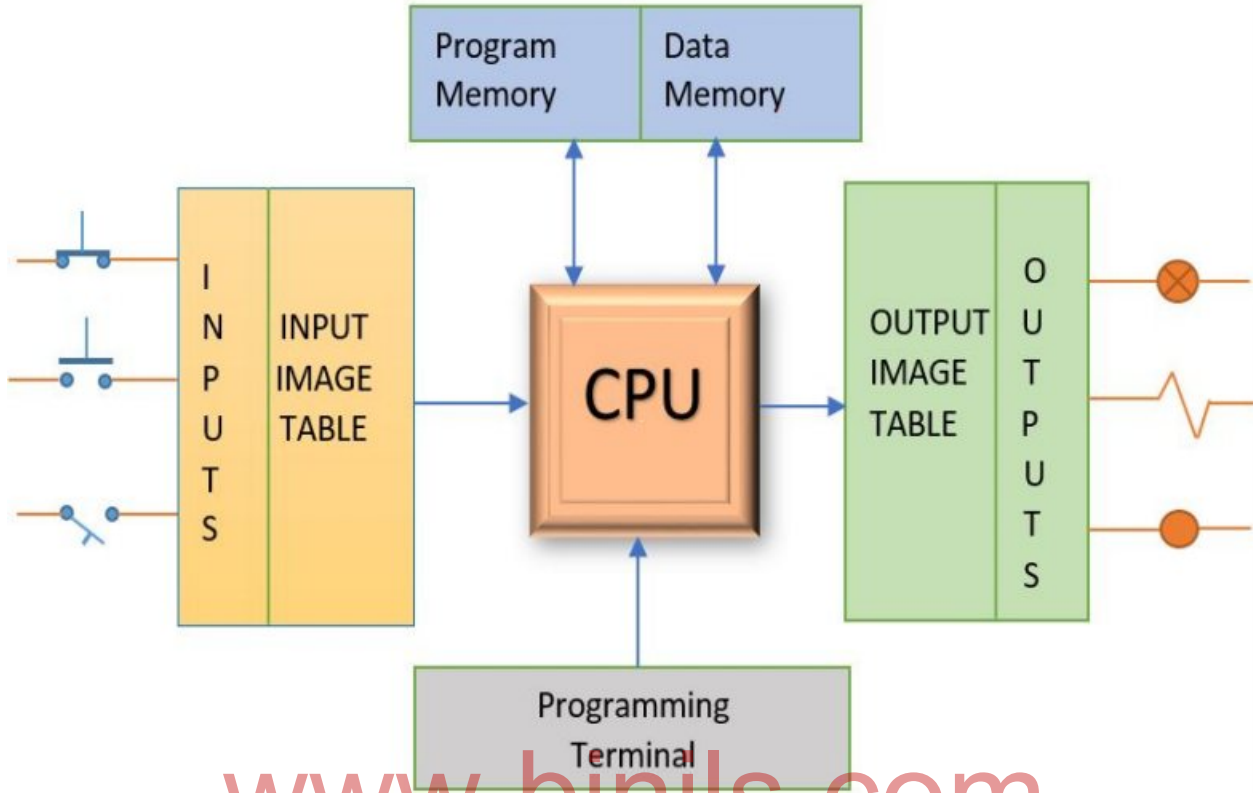

Fig. 5.23 PLC block diagram

A simplified block diagram of a PLC, is shown in above Fig. It has three major units/sections.

1. I/O (Input / Output) Modules.
2. CPU (Central Processing Units).
3. Programmer/Monitor.

1) I/O Section:

- The I/O section establishes the interfacing between physical devices in the real world outside the PLC and the digital arena inside the PLC. The input module has bank of terminals for physically connecting input devices, like push buttons, limit switches etc. to a PLC.
- The role of an input module is to translate signals from input devices into a form that the PLC's CPU can understand.
- The Output module also has bank of terminals that physically connect output devices like solenoids, motor starters, indicating lamps etc. to a PLC. The role of an output module is to translate signals from the PLC's CPU into a form that the output device can use.

The tasks of the I/O section can be classified as:

- Conditioning

- Isolation
- Termination
- Indication

2) CPU Section:

The Central Processing Unit, the brain of the system is the control portion of the PLC. It has three Subparts.

- Memory System
- Processor
- Power Supply

Memory System:

The memory is the area of the CPU in which data and information is stored and retrieved. The total memory area can be subdivided into the following four Sections.

I/O Image Memory

- The input image memory consists of memory locations used to hold the ON or OFF states of each input field devices, in the input status file.
- The output status file consists of memory locations that stores the ON or OFF states of hardware output devices in the field. Data is stored in the output status file as a result of solving user program and is waiting to be transferred to the output module's switching device.

Data Memory

It is used to store numerical data required in math calculation, bar code data etc.

User Memory

It contains user's application program.

Executive Memory

It is used to store an executive program or system software. An operating system of the PLC is a special program that controls the action of CPU and consequently the execution of the user's program.

Processor:

The processor, the heart of CPU is the computerized part of the CPU in the form of Microprocessor / Micro controller chip.

- It reads the information. It stores this information in memory for later use.

- It carries out mathematical and logic operations as specified in application program. It sends data out to external devices like output module, so as to actuate field hardware.
- It performs peripheral and external device communication. It performs self diagnostics.

Power Supply:

- The power supply provides power to memory system, processor and I/O Modules.
- It converts the higher level AC line Voltage to various operational DC values.
- for electronic circuitry.
- It filters and regulates the DC voltages to ensure proper computer operations.

3) Programmer/Monitor:

- The Programmer/Monitor (PM) is a device used to communicate with the circuits of the PLC. The programming unit allows the engineer/technicians to enter the edit the program to be executed.
- In its simplest form it can be hand-held device with membrane keypad for program entry and a display device (LED or LCD) for viewing program steps of functions.

5.7.3 PLC scan

A PLC is to perform specific duties in a specific sequence and then continuously repeat the sequence is called PLC scan.

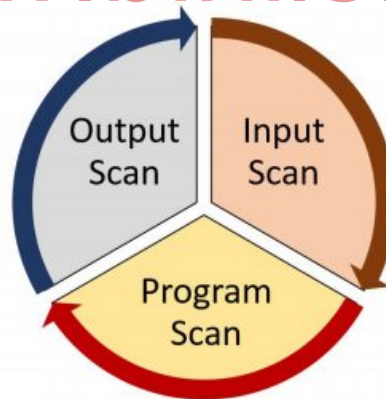

Fig.5.24 PLC scan

PLC scan consists of,

- Input scan

- Program scan
- Output scan

Input Scan

Input terminals are read and input image table is prepared. During this scan the PLC reads the status of inputs from input module and stores them in the input image table before execution of program.

Program Scan

During this scan, the PLC executes the user program by taking the input data from the input image table. The instructions are carried out in sequence manner and depending upon the logic, the outputs are produced.

Output Scan

Read output image; provide 0 or 1 logic to the output device.

5.7.4 Modular and Fixed PLCs

- PLCs have two main categories: modular or fixed. Both have the same basic functions.
- Modular PLCs, also known as rack-mounted units, consist of bases allowing for many independent components, such as the installation of numerous I/O modules. These are easier to repair.
- Modular PLCs allow users to mix and select the best combination of CPUs, communication devices, specialist control modules and discrete I/O on a back-plane.
- Fixed PLCs are typically designed to perform basic functions. They are small and consist of a power supply and the CPU and I/O systems, which are all housed in one entity. The proper functioning of all processes largely depends on the flawless execution of every component.

Advantages of Modular PLCs

- Memory
- Greater number of available I/O Modules
- Room for Expansion
- Mix and Match.

5.7.5 PLC Ladder logic

Ladder logic is the most widely used programming language with PLCs. The vertical line of a ladder diagram represents the power or energized conductor. The right vertical line

represents the neutral or return path of the circuit. Ladder logic diagrams are read from left to right and top to bottom. The horizontal line is known as rung or network. A network has several control elements but only one output element. Each rung must have at least one input and input (or) control element must be followed by an output.

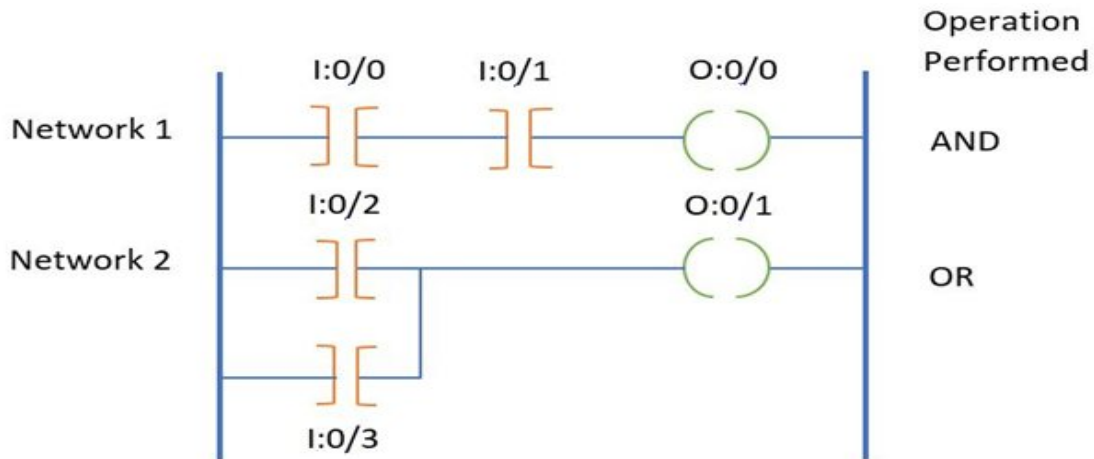



www.binils.com

Fig. 5.25 Ladder logic diagram

- In the above example, I:0/0, I:0/1, I:0/2 and I:0/3 are inputs and it may be switches, push buttons. O:0/0 and O:0/1 are output and it may be a relay coils.
- The first rung contains I:0/0, I:0/1 and O:0/0 instruction combination. In this rung, the output relay (or) coil O:0/0 is energized only when both the inputs are energized.
- The second rung contains I:0/2, I:0/3 and O:0/1 instruction combination. In this rung, the output relay (or) coil O:0/1 is energized when any one of the input I:0/2 or I:0/3 is energized.

Symbols used in Ladder logic Diagram

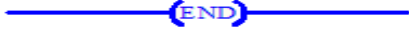
SL.NO	LADDER SYMBOL	TYPICAL HARDWARE COMPONENTS
1.		NORMALLY OPEN CONTACT (SWITCH, PUSH BOTTONS, LIMIT SWITCH, AUXILIARY RELAY CONTACTS, OTHER ON/OFF DEVICES ETC.,)
2.		NORMALLY CLOSED CONTACT (SWITCH, PUSH BOTTONS, LIMIT SWITCH, AUXILIARY RELAY CONTACTS, OTHER ON/OFF DEVICES ETC.,)
3.		OUTPUT ENERGIZE (CONTACTOR COILS, INDICATING LAMPS, MOTORS, ALARAM, SOLINOID ETC.,)
4.		END

www.binils.com

AND logic

The AND gate is associated with the following symbol that can have any number of inputs but only one output. The truth table below shows that the output is only turned on when all the inputs are true (1). An easy way to remember this is AND works like multiplication

AND gate ladder Logic Diagram

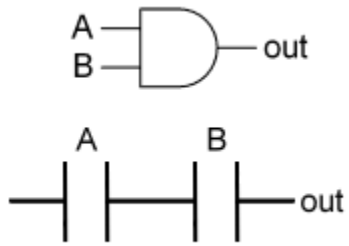

Input A	Input B	Output
0	0	0
1	0	0
0	1	0
1	1	1

www.binils.com

Truth Table

The ladder logic equivalent for an AND function looks like two normal contacts side by side.

OR logic

The OR gate is associated with the following symbol that also can have any number of inputs but only one output. The truth table below shows that the output is turned on (1) when any of the inputs are true (1). An easy way to remember this is OR works like addition.

www.binils.com

OR gate ladder logic diagram

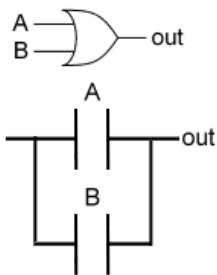

Input A	Input B	Output
0	0	0
1	0	1
0	1	1
1	1	1

Truth Table

www.binils.com

The ladder logic equivalent for an OR function looks like two normal contacts on top of each other.

REVIEW QUESTIONS

PART- A

1. Mention any two types of switches
2. Expand MCCB.
3. Expand MCB.
4. Expand OCB.
5. Expand ELCB
6. State the use of MCB.
7. State the different types of sensors.
8. State any two features of PLC.
9. State any three parts of PLC.
10. Expand CPU.

PART-B

11. What is meant by fuse?
12. What is the need of fuse?
13. Draw the symbol of NO and NC contact.
14. What is meant by relay?
15. What is PLC?
16. What is sensor?
17. What is meant by contactor?
18. Mention the two contact of a relay.
19. What is photo electric sensor?
20. Draw the symbols of NAND ,NOT,AND gates.

PART-C

21. Explain fuse switch units.
22. Explain the working of photo electric sensor.
23. Explain the working of inductive proximity sensor.
24. Explain the working of proximity sensor.
25. Draw the neat diagram of oil circuit breaker and explain its working.
26. Explain how the earth leakage circuit breaker can be applied in electrical circuit.
27. What is meant by contactor and explain the working of solenoid type contactor.
28. Explain the operation of bimetallic thermal overload relay.
29. Explain the operation of MCB and MCCB.
30. Draw the block diagram of PLC and explain the each block.
31. What is PLC scanning and explain briefly?
32. Draw and explain the ladder logic diagram for AND and OR gate?

www.binils.com