



Reg. No. :

--	--	--	--	--	--	--	--	--	--	--	--	--	--	--	--	--	--	--	--

Question Paper Code : 41403

B.E./B.Tech. DEGREE EXAMINATION, APRIL/MAY 2018

Fourth/Fifth/Sixth Semester

Mechanical Engineering

ME 6503 – DESIGN OF MACHINE ELEMENTS

(Common to Mechanical Engineering (Sandwich)/Automobile Engineering/
Industrial Engineering/Mechanical and Automation Engineering/Mechatronics
Engineering)
(Regulations 2013)

Time : Three Hours

Maximum : 100 Marks

Answer ALL questions.

PART – A

(10×2=20 Marks)

1. What are preferred numbers ?
2. Brief about Soderberg and Goodman lines.
3. Write the advantages that hollow shafts offer as compared to solid shafts.
4. Write Rayleigh-Ritz equation to determine the critical speed of shaft subjected to point loads.
5. List out the advantages of the V-threads.
6. What is Caulking and Fullering process in riveted joints ? Why is it used ?
7. Define surge in Springs.
8. State functions of flywheel.
9. What are essential condition for wedge film formation in Hydro dynamic bearing ?
10. Define load factor and explain its significance in related to bearing selection.

41403

-2-



PART - B

(5×13=65 Marks)

11. a) A wall bracket with rectangular cross section is shown in figure 11 (a). The depth of the cross section is twice that of the width. The force P acting on the bracket at 60° to the vertical is 5 kN. The material of the bracket is Grey Cast iron FG 200 and the factor of safety is 3.5. Determine the dimensions of the cross sections of the bracket. Assume maximum normal stress theory of failure. (13)

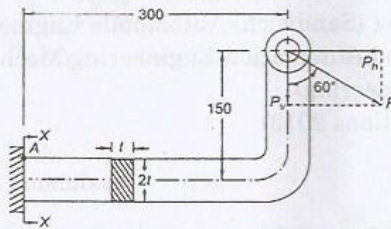

Fig. 11 (a)

(OR)

- b) The C-Frame of a 100 kN capacity press is shown in figure 11 b (i), 11 b (ii). The material of the frame is FG 200. Assuming the factor of safety as 3, determine the dimensions of the frame. (13)

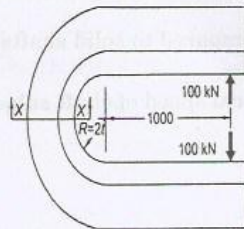

Fig. 11. b (i)

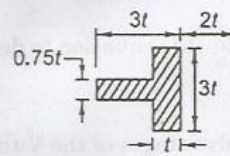

Fig. 11. b (ii)

12. a) A rigid coupling is used to transmit 50 kW power at 300 rpm. There are six bolts the outer diameter of the flanges is 220 mm, while the recess diameter is 150 mm. The coefficient of friction between the flanges is 0.15. The bolts are made of steel 45C8 ($S_{yt} = 380 \text{ N/mm}^2$) and the factor of safety is 3. Determine the diameter of the bolts. Assume that the bolts are fitted in large clearance holes. (13)

(OR)



- b) A transmission shaft supporting a helical gear B and an overhang bevel gear D is shown in figure 12. b. The shaft is mounted on two bearings A and C. The pitch circle diameter of the helical gear is 450 mm and the diameter of the bevel gear at the forces is 450 mm. Power is transmitted from the helical gear to the bevel gear. The gears are keyed to the shaft. The material of the shaft is steel 45C8 ($S_{ut} = 600$ and $S_{yt} = 380 \text{ N/mm}^2$). The factors k_b and k_t of ASME code are 2.0 and 1.5 respectively. Determine the shaft diameter using the ASME code. (13)

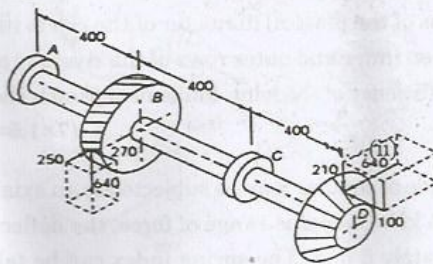

Fig. 12. (b)

13. a) The structural connection shown in figure 13. a. i) is subjected to an eccentric force P of 10 kN with an eccentricity of 500 mm from the CG of the bolts. The centre distance between bolts 1 and 2 is 200 mm, and the centre distance between bolts 1 and 3 is 150 mm. All the bolts are identical. The bolts are made from plain carbon steel 30C8 ($S_{yt} = 400 \text{ N/mm}^2$) and the factor of safety is 2.5. Determine the size of the bolts. (13)

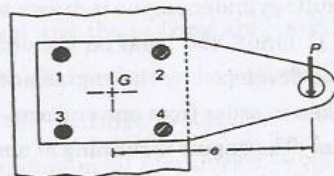

Fig. 13. a (i)

(OR)

41403

-4-



- b) A cylindrical steam pressure vessel of 1 m inside diameter is subjected to an internal pressure of 2.5 MPa. Design a double-riveted, double-strap longitudinal butt joint for the vessel. The straps are of equal width. The pitch of the rivets in the outer row should be twice of the pitch in the inner row. A zig-zag pattern is used for rivets in inner and outer rows. The efficiency of the riveted joint should be at least 70%. The permissible tensile strength for the steel plate of pressure vessel is 80 N/mm^2 . The permissible shear stress for the rivet material is 60 N/mm^2 . Assume that the rivets in double shear are 1.875 times stronger than in single shear and the joint do not fail by crushing. Calculate i) thickness of the plate ii) diameter of the rivets iii) pitch of the rivets iv) distance between inner and outer rows of the rivets v) margin vi) thickness of the straps vii) efficiency of the joint. Make neat sketch showing all the calculated dimensions. (7×1.5= 10.5+2.5)

14. a) A helical compression spring made of circular wire, is subjected to an axial force, which varies from 2.5 kN to 3.5 kN. Over this range of force, the deflection of the spring should be approximately 5 mm. The spring index can be taken as 5. The spring has square and ground ends. The spring is made of patented and cold-drawn steel wire and ultimate tensile strength of 1050 N/mm^2 and modulus of rigidity of 81370 N/mm^2 . The permissible shear stress for the spring wire should be taken as 50% of the ultimate tensile strength. Design the spring and calculate i) Wire diameter ii) mean coil diameter iii) number of active coils iv) total number of coils v) solid length of spring vi) free length of spring vii) required spring rate viii) actual spring rate. (8×1.5= 12+1)

(81)

(OR)

- b) The turning moment diagram of a multi-cylinder engine is drawn with a scale of $(1 \text{ mm} = 1^\circ)$ on the abscissa and $(1 \text{ mm} = 250 \text{ N-m})$ on the ordinate. The intercepted areas between the torque developed by the engine and the mean resisting torque of the machines, taken in order from one end are $-350, +800, -600, +900, -550, +450$ and -650 mm^2 . The engine is running at a mean speed of 750 rpm and the coefficient of speed fluctuation is limited to 0.02. A rimmed flywheel made of grey cast iron FG 200 (density = 7100 kg/m^3) is provided. The spokes, hub and shaft are assumed to contribute 10% of the required moment of inertia. The rim has rectangular cross-section and the ratio of width to thickness is 1.5. Determine the dimensions of the rim. (13)



15. a) A shaft transmitting 50 kW at 1255 rpm from the gear G_1 to the gear G_2 and mounted on two single-row deep groove ball bearings B_1 and B_2 as shown. The gear tooth forces are $P_{t1} = 15915$ N, $P_{r1} = 5793$ N, $P_{t2} = 9549$ N and $P_{r2} = 3476$ N. The diameter of the shaft at bearings B_1 and B_2 is 75 mm. The load factor is 1.4 and the expected life for 90% of the bearings is 10000 h. Select suitable ball bearings. Refer figure 15 (a). (13)

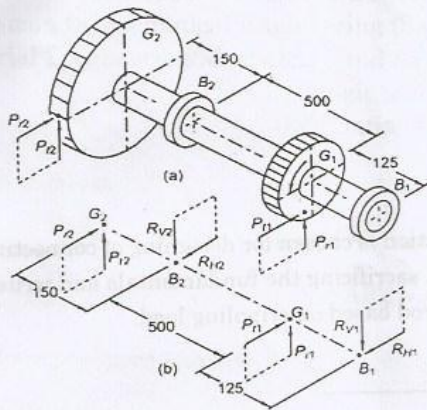

Fig. 15. (a)

(OR)

- b) The following data is given for a full hydrodynamic bearing used for electric motor radial load = 1200 N; journal speed = 1440 rpm; journal diameter = 50 mm static load on the bearing = 350 N. The values of surface roughness of the journal and the bearing are 2 and 1 micron respectively. The minimum oil film thickness should be five times the sum of surface roughness of the journal and the bearings. Determine i) length of the bearing ii) radial clearance iii) minimum oil film thickness iv) viscosity of lubricant v) flow of lubricant select a suitable oil for this application assuming the operating temperature as 65°C. (2+2+2+4+3)

41403

-6-



PART - C

(1×15=15 Marks)

16. a) Determine the stress at point A and B split ring shown in fig. 16 (a). if a compressive force = 20 kN is applied point 'C'. (15)

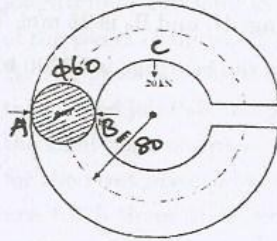

Fig. 16 (a)

(OR)

- b) Explain why the standard I-Section is chosen for designing of connecting rod over other cross section without sacrificing the fundamentals and write the design equation for connecting rod based on crippling load. (15)