

additional product terms from other macrocells in the same logic block, apart from a maximum of five product terms from within the same macrocell.

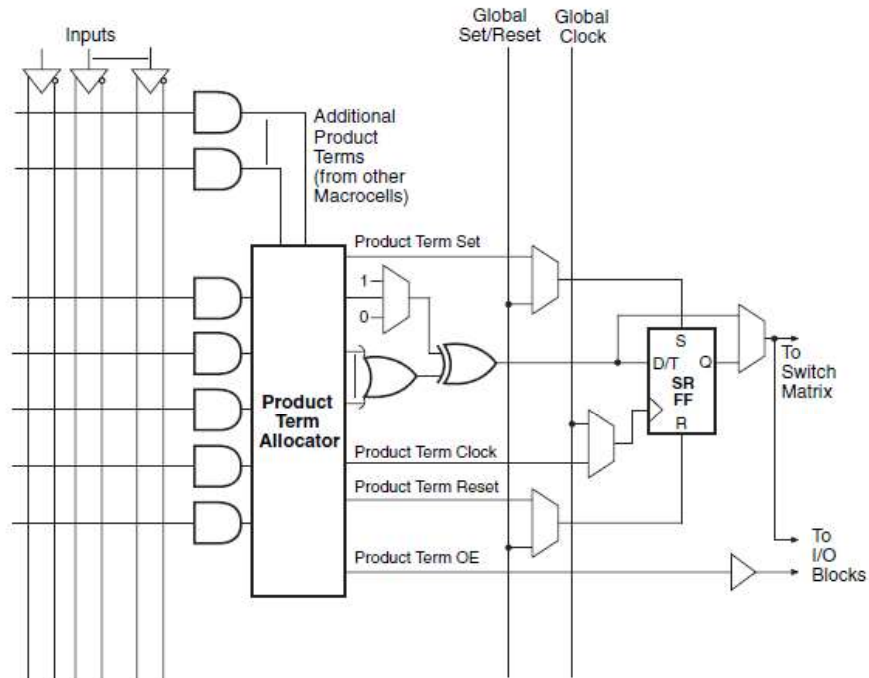

Figure 4.23 Macrocell architecture

Figure 4.23 shows the logic diagram of a macrocell typical of macrocells in the logic blocks of most contemporary CPLDs. The diagram is self-explanatory. There may be minor variations in devices from different manufacturers. For example, macrocells in the XC-7000 series CPLDs from Xilinx have two OR gates fed from a two-bit arithmetic logic unit (ALU) and its output feeds a configurable flip-flop.

4.9 Two marks Questions and Answers

1. **Explain ROM**

A read only memory (ROM) is a device that includes both the decoder and the OR gates within a single IC package. It consists of n input lines and m output lines. Each bit combination of the input variables is called an address. Each bit combination that comes out of the output lines is called a word. The number of distinct addresses possible with n input variables is 2^n .

2. **What are the types of ROM?**

1. PROM 2. EPROM 3. EEPROM

3. **Explain PROM.**

PROM (Programmable Read Only Memory)

It allows user to store data or program. PROMs use the fuses with material like nichrome and polycrystalline. The user can blow these fuses by passing around 20 to 50 mA of current for the period 5 to 20 μ s. The blowing of fuses is called programming of ROM. The PROMs are one time programmable. Once programmed, the information is stored permanent.

4. **Explain EPROM.**

EPROM(Erasable Programmable Read Only Memory)

EPROM use MOS circuitry. They store 1's and 0's as a packet of charge in a buried layer of the IC chip. We can erase the stored data in the EPROMs by exposing the chip to ultraviolet light via its quartz window for 15 to 20 minutes. It is not possible to erase selective information. The chip can be reprogrammed.

5. **Explain EEPROM.**

EEPROM(Electrically Erasable Programmable Read Only Memory) EEPROM also use MOS circuitry. Data is stored as charge or no charge on an insulated layer or an insulated floating gate in the device. EEPROM allows selective erasing at the register level rather than erasing all the information since the information can be changed by using electrical signals.

6. **What is RAM?**

Random Access Memory. Read and write operations can be carried out.

7. **Define ROM**

A read only memory is a device that includes both the decoder and the OR gates within a single IC package.

8. **Define address and word:**

In a ROM, each bit combination of the input variable is called on address. Each bit combination that comes out of the output lines is called a word.

9. **What are the types of ROM.**

Masked ROM.

Programmable Read only Memory

Erasable Programmable Read only memory.

Electrically Erasable Programmable Read only Memory

10. **What is programmable logic array? How it differs from ROM?**

In some cases the number of don't care conditions is excessive, it is more economical to use a second type of LSI component called a PLA. A PLA is similar to a ROM in concept; however it does not provide full decoding of the variables and does not generates all the minterms as in the ROM.

11. **What is mask - programmable?**

With a mask programmable PLA, the user must submit a PLA program table to the manufacturer.

12. **What is field programmable logic array?**

The second type of PLA is called a field programmable logic array. The user by means of certain recommended procedures can program the EPLA.

13. **List the major differences between PLA and PAL**

PLA:

Both AND and OR arrays are programmable and Complex
Costlier than PAL

PAL :

AND arrays are programmable OR arrays are fixed
Cheaper and Simpler

14. **Define PLD.**

Programmable Logic Devices consist of a large array of AND gates and OR gates that can be programmed to achieve specific logic functions.

15. **Give the classification of PLDs.**

PLDs are classified as PROM(Programmable Read Only Memory), Programmable Logic Array (PLA), Programmable Array Logic (PAL), and Generic Array Logic(GAL)

16. **Define PROM.**

PROM is Programmable Read Only Memory. It consists of a set of fixed AND gates connected to a decoder and a programmable OR array.

17. **Define PLA.**

PLA is Programmable Logic Array (PLA). The PLA is a PLD that consists of a Programmable AND array and a programmable OR array.

18. **Define PAL.**

PAL is Programmable Array Logic. PAL consists of a programmable AND array and a fixed OR array with output logic.

19. **Why was PAL developed?**

It is a PLD that was developed to overcome certain disadvantages of PLA, such as longer delays due to additional fusible links that result from using two programmable arrays and more circuit complexity.

20. **Define GAL.**

GAL is Generic Array Logic. GAL consists of a programmable AND array and a fixed OR array with output logic.

21. Why the input variables to a PAL are buffered

The input variables to a PAL are buffered to prevent loading by the large number of AND gate inputs to which available or its complement can be connected.

22. What does PAL 10L8 specify?

PAL - Programmable Logic Array

10 - Ten inputs

L - Active LOW Output, 8 - Eight Outputs

23. What is CPLD?

CPLDs are Complex Programmable Logic Devices. They are larger versions of PLDs with a centralized internal interconnect matrix used to connect the device macro cells together.

24. Define bit, byte and word.

The smallest unit of binary data is bit. Data are handled in an 8 bit unit called byte. A complete unit of information is called a word which consists of one or more bytes.

25. How many words can a 16x8 memory can store?

A 16x8 memory can store 16,384 words of eight bits each

26. Define address of a memory.

The location of a unit of data in a memory is called address.

27. What is Read and Write operation?

The Write operation stores data into a specified address into the memory and the Read operation takes data out of a specified address in the memory.

28. Why RAMs are called as Volatile?

RAMs are called as Volatile memories because RAMs lose stored data when the power is turned OFF.

29. Define ROM.

ROM is a type of memory in which data are stored permanently or semi permanently. Data can be read from a ROM, but there is no write operation.

30. Define RAM.

RAM is Random Access Memory. It is a random access read/write memory. The data can be read or written into from any selected address in any sequence.

31. List the two categories of RAMs.

The two categories of RAMs are static RAM(SRAM) and dynamic RAM (DRAM).

32. **Define Static RAM and dynamic RAM.**
Static RAM use flip flops as storage elements and therefore store data indefinitely as long as dc power is applied.
Dynamic RAMs use capacitors as storage elements and cannot retain data very long without capacitors being recharged by a process called refreshing.
33. **List the two types of SRAM.**
Asynchronous SRAMs and Synchronous Burst SRAMs
34. **List the basic types of DRAMs.**
Fast Page Mode DRAM, Extended Data Out DRAM(EDO DRAM),Burst EDO DRAM and Synchronous DRAM.
35. **Define a bus.**
A bus is a set of conductive paths that serve to interconnect two or more functional components of a system or several diverse systems.
36. **Define Cache memory.**
It is a relatively small, high-speed memory that can store the most recently used instructions or data from larger but slower main memory.
37. **What is the technique adopted by DRAMs.**
DRAMs use a technique called address multiplexing to reduce the number of address lines.
38. **Give the feature of UV EPROM.**
UV EPROM is electrically programmable by the user, but the store data must be erased by exposure to ultra violet light over a period of several minutes.
39. **Give the feature of flash memory.**
The ideal memory has high storage capacity, non-volatility; in-system read and write capability, comparatively fast operation. The traditional memory technologies such as ROM, PROM, EEPROM individually exhibits one of these characteristics, but no single technology has all of them except the flash memory.
40. **What are Flash memories?**
They are high density read/write memories that are non-volatile, which means data can be stored indefinitely without power.
41. **List the three major operations in a flash memory.**
Programming, Read and Erase operation

42. **What is a FIFO memory?**

The term FIFO refers to the basic operation of this type of memory in which the first data bit written into the memory is to first to be read out.

43. **List basic types of programmable logic devices.**

Read only memory
Programmable logic Array
Programmable Array Logic

44. **Define address and word:**

In a ROM, each bit combination of the input variable is called on address. Each bit combination that comes out of the output lines is called a word.

45. **What is programmable logic array? How it differs from ROM?**

In some cases the number of don't care conditions is excessive, it is more economical to use a second type of LSI component called a PLA. A PLA is similar to a ROM in concept; however it does not provide full decoding of the variables and does not generates all the minterms as in the ROM.

46. **What is mask - programmable?**

With a mask programmable PLA, the user must submit a PLA PLA program table to the manufacturer.