

Reg. No. :

--	--	--	--	--	--	--	--	--	--	--	--	--	--	--	--	--	--	--	--

Question Paper Code : 53125

B.E./B.Tech. DEGREE EXAMINATIONS APRIL/MAY 2019.

First Semester

Mechanical Engineering

GE 6152 – ENGINEERING GRAPHICS

(Common to all branches)

Time : Three hours

Maximum : 100 marks

Answer ALL questions.

(5 × 20 = 100)

1. (a) (i) A String of length 220 mm is wound round a circle of radius 25 mm. Draw the path traced by the end of the string. Also draw a tangent and normal to a point on the involute. (10)
- (ii) Construct a vernier scale of RF = 1/30 to read centimeters upto 5 meters and on it show lengths of 3.72 m and 2.86 m. (10)

Or

- (b) Sketch by free hand the top view, front view and any one side view of the object shown, all dimensions are in mm.

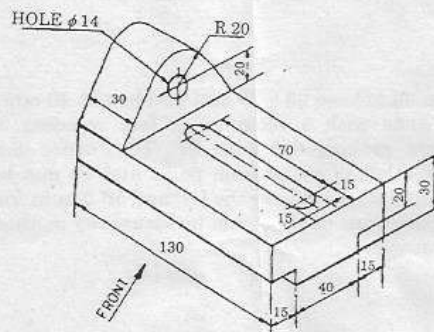

2. (a) The end P of a line PQ, 70 mm long is 15 mm above the HP and 20 mm in front of the VP. Q is 40 mm above the HP. The top view of the line is inclined at 45° to the VP. Draw the projections of the line and find its true inclination with the VP and the HP.

Or

- (b) A rectangular plate measuring 70×40 mm has one of its shorter edges in the VP inclined at 40° to the HP. Draw its top view if its front view is a square of side 40 mm. Draw its projections and also find the true inclination of the plate with the VP.
3. (a) A hexagonal pyramid with 30 mm base side and 70 mm long axis is lying on a slant edge on the ground such that the axis is parallel to the V.P. Draw its projections. (20)

Or

- (b) A hexagonal prism of 30 mm base side and axis 65 mm long, has an edge of its base in the V.P. such that the axis is inclined at 30° to the V.P. and parallel to the H.P. Draw its projections. (20)
4. (a) A cube of side 30 mm rests on the HP on its end with the vertical faces equally inclined to the VP. It is cut by a plane perpendicular to the VP and inclined at 30° to the HP meeting the axis at 25 mm above the base. Draw its front view, sectional top view and the true shape of the section.

Or

- (b) A circular hole of diameter 30 mm is drilled through a vertical cylinder of diameter 50 mm and height 65 mm. The axis of the hole is perpendicular to the VP and meets the axis of the cylinder at right angles at a height of 30 mm above the base. Draw the development of the lateral surface of the cylinder.
5. (a) Draw the isometric view of a frustum of a hexagonal pyramid when it is resting on its base on the HP with two sides of the base parallel to the VP. The side of base is 20 mm and top 8 mm. The height of the frustum is 55 mm.

Or

- (b) A square prism of base 25×25 mm and height 40 mm rests on the GP on one of its ends with a rectangular face receding away from the PP towards right making 60° with PP. The corner nearest to the PP is 40 mm to the left of the station point and 20 mm behind the PP. The Station point is 60 mm above the GP and 50 mm in front of the PP. Draw the perspective view of the prism by visual ray method. Use the top view and the front view.